

ACADEMY

HOBBY MODEL KITS

TA980



미육군 자주포 전차 M-18 헬캣

1/35 SCALE

M-18 HELLCAT

U.S. ARMY GUN MOTOR CARRIAGE

【 TECHNICAL SPECIFICATION 】

CREW : 5 men

DIMENSIONS

- *Length overall : 262 in.
- *Hull length : 214 in.
- *Width : 113 in.
- *Height : 101½ in.
- *Clearance : 14¼ in.

WEIGHT

- *Loaded : 37,557 pdrs.
- *Empty : 35,526 pdrs.

GROUND PRESSURE : 11.9p.s.i.

ARMOR

- *Turret Front : 1 in.
- *Turret Sides & Rear : ½ in.
- *Hull front, Sides, Rear : ½ in.
- *Hull Top : ⅓ in.
- *Hull Floor : ¼ in.

ARMAMENT

- *1×76mm M1/M1A1 Gun/
- *1×12.7mm Cal.50 MG

AMMUNITION : 45 / 840 rounds

PERFORMANCE

- *Max speed : 55 miles/h
- *Trench crossing : 74 in.
- *Fording depth : 48 in.
- *Max gradient : 60 %
- *Range : 105 miles
- *Turning radius : 33 ft.

TRACK : T-69 Steel 14.38 in.,
Pitch 5.11 in.

SUSPENSION

- *Torsion bar
- *Road wheels 26 in.×4½ in.

ENGINE

Continental R-975 C1 340hp
/C4 400hp 9cylinder aircooled

TRANSMISSION : Torqmatic 3FIR

FUEL : 170 U.S.gallons

PRODUCTION

A Total of 2,507 vehicles in July
1943 until March 1945.

【 성능 및 제원 】

승무원 : 5명

길이

- *전장 : 665.48 cm
- *차체장 : 543.56 cm
- *전폭 : 287.02 cm
- *전고 : 257.65 cm
- *지상고 : 36.2 cm

중량

- *전투 중량 : 17톤
- *차체 중량 : 16.1톤

접지압 : 0.83 kg/cm²

장갑

- *포탑 전면 : 2.54 cm
- *포탑 측,후면 : 1.27 cm
- *차체 전,측,후면 : 1.27 cm
- *차체 상면 : 0.8 cm
- *차체 하면 : 0.64 cm

무장

- *7.5 cm M1/M1A1 주포 1문/
- *1.27 cm Cal.50 기관총 1정

탄약 : 포탄45 / 기총탄840발

기동성

*최대 속도 : 88 km/h

*초호(超壕) 반경 : 188 cm

*도하 수심 : 122 cm

*행동 거리 : 168 km

*선회 반경 : 1000 cm

캐터필러 : T-69 철제 36.5 cm,

피치 12.9 cm

서스펜션

*토션 바식

*전륜 66.04 cm×11.43 cm

엔진

콘티넨탈 R-975 C1 340마력

/C4 400마력 9기통 공냉식

트랜스미션 : 토오크매틱 3FIR

연료적재량 : 643.45 리터

생산

1943년 7월부터 1945년 3월

까지 총 2,507대 생산.

#1375

■ 조립하기전에

- 제품을 조립하기전에 설명서를 끝까지 잘 읽어본다.
- 부품을 자를때에는 칼이나 니퍼로 깨끗이 잘라준다.
- 접착하기전에 부품을 맞추어 확인한 후 접착한다.
- 접착제를 사용할 곳과 사용하지않는 곳에 주의하고 너무 많이 바르지 않도록 한다.
- 에나멜 페인트나 접착제를 사용할때에는 창문을 열어 환기를 시키고 화기를 멀리한다.

■ 판매점 및 A/S센터: 삼성교:742-9293, 대치동:562-9293,

용산:706-9293, 양재동:575-9997

■ 아카데미 총판점: 양천아카데미:691-7108, 강남아카데미:522-1577,
노원아카데미:907-0940, 경기아카데미:(0343)458-5591,
부산(051)293-7449, 대구(053)744-9293

■ A/S센터:본사: 908-7000(교현147), 등대문:745-9293, 천호동:473-9293

☎고객상담문의: 080-969-7000(수신자부담)

■ 홈페이지: <http://www.academy.co.kr> <http://www.academyhobby.com>

● → 접착한다. CEMENT ● - - - - - → 접착금지. DO NOT CEMENT
※ ()는 반대측 부품 번호임. () is opposite number.

1

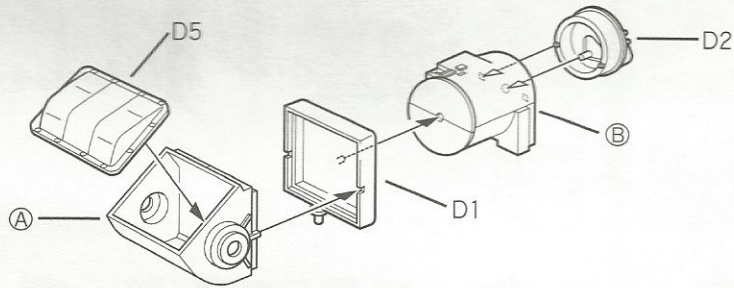
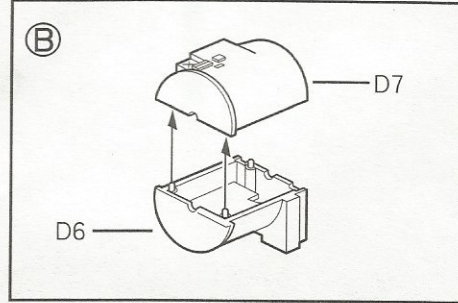
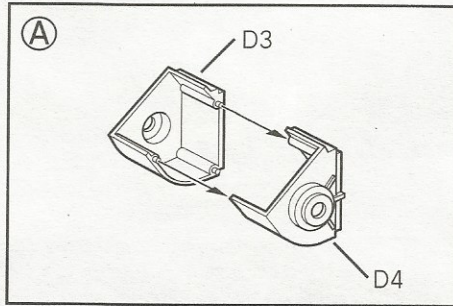

▶무광백색 Flat White

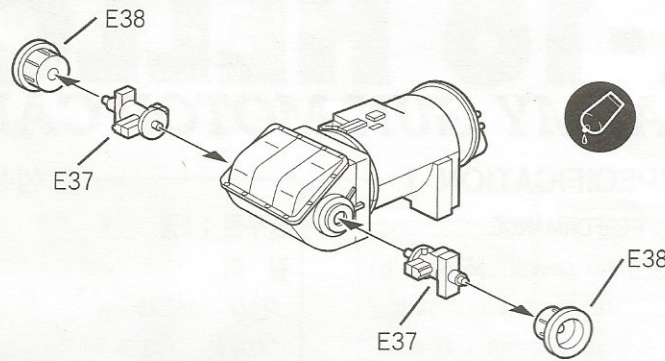

2

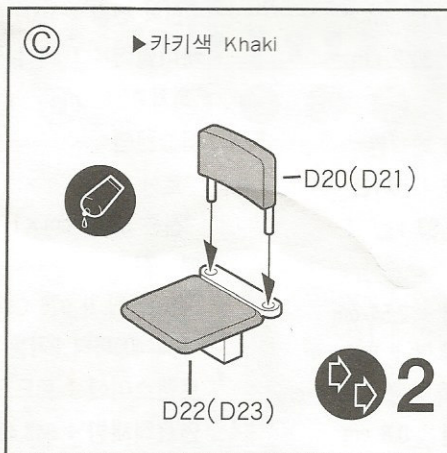

▶카키색 Khaki

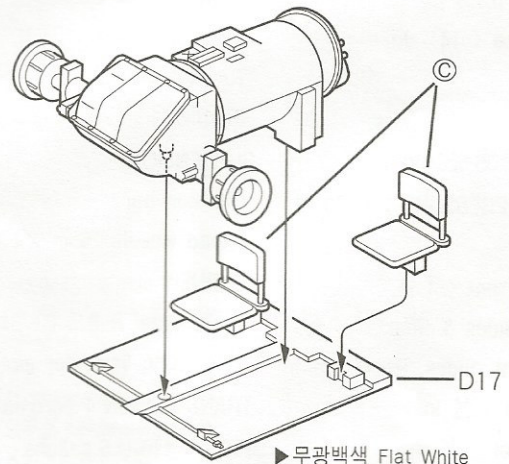

▶무광백색 Flat White



접착한다.
Cement Parts
Coller
Kleben
Pagar
Incollare
Colar
Kleven



접착하지 않는다.
DO NOT cement
Ne pas coller
Nicht kleben
NO Pagar
NON incollare
Nao colar
Niet kleven



잘라낸다.
Cut away
Couper
scheiden
Cortar
Tagliare
Cortar
Snijden



선택한다.
Optional parts
Choix
Auswahlmöglichkeit
Eleccion
Scelta
Opcao
Keuze



3

수만큼 조립한다.
Repeat operation
Répéter l'operation
Vorgang wiederholen
Repitir la operacion
Ripetere
Ripitir a operacao
Herhalen

3

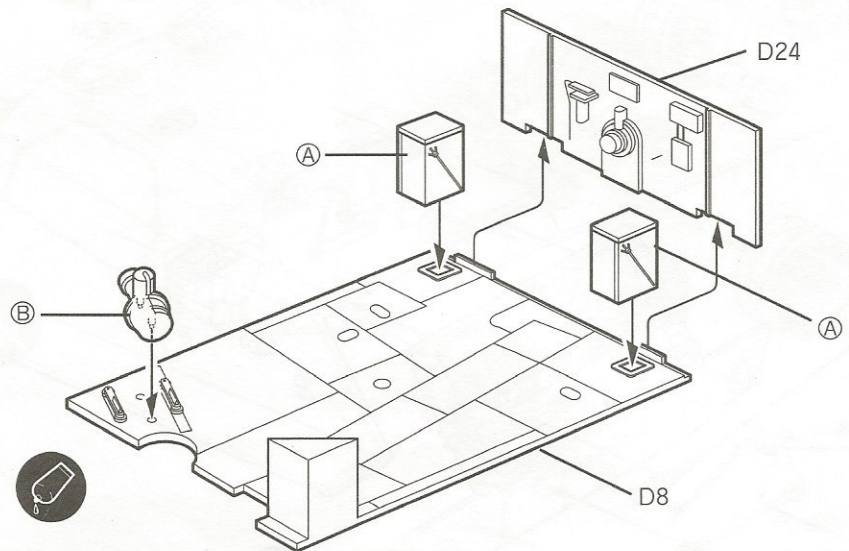
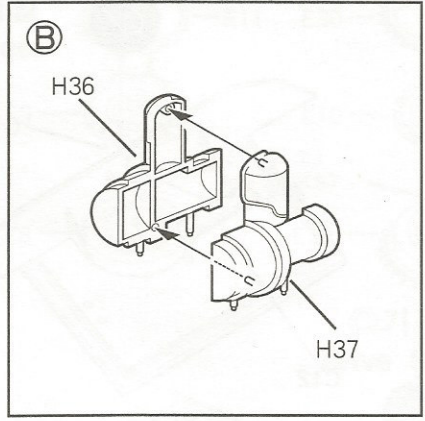
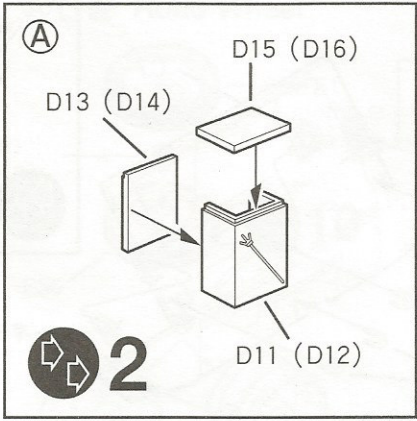

4

▶ 차체 내부색 Hull Interior
 전체 무광백색 Overall Flat White

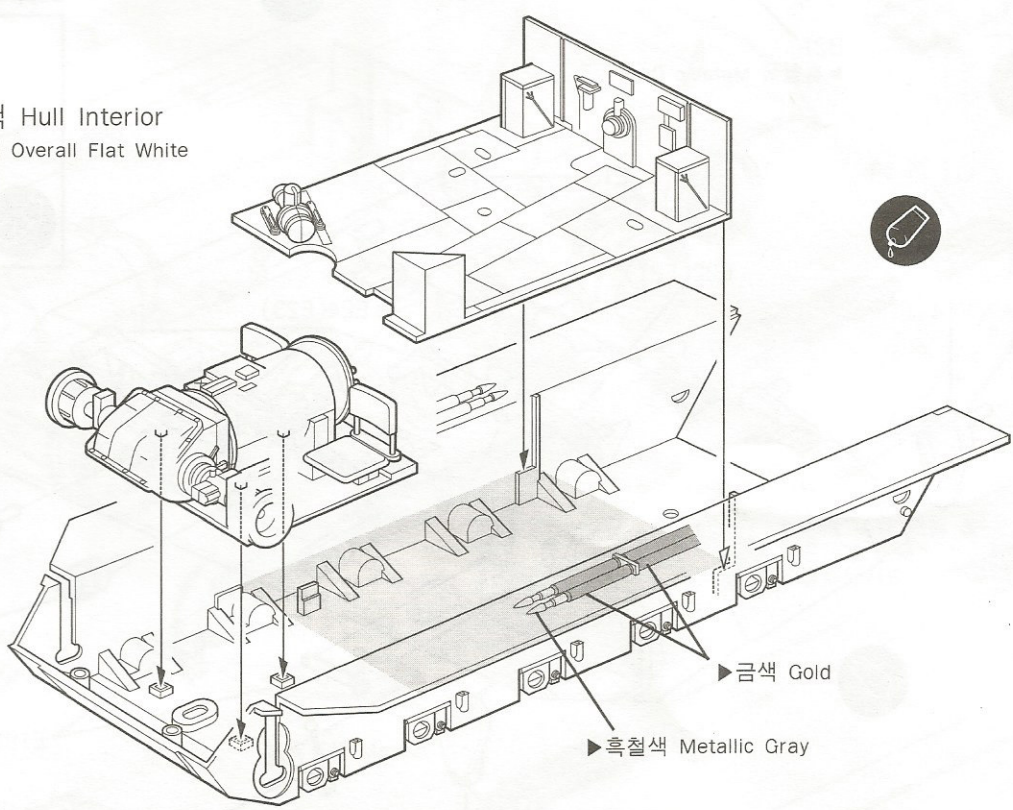

5

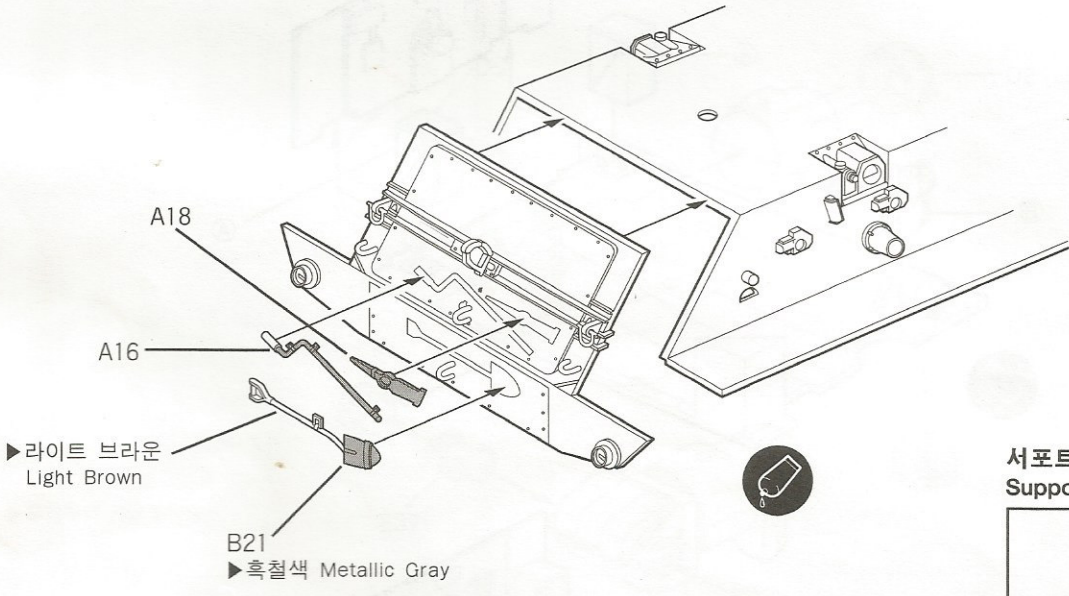
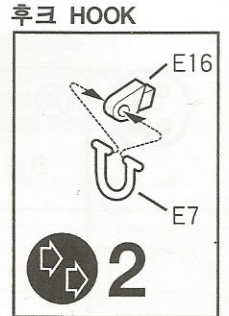
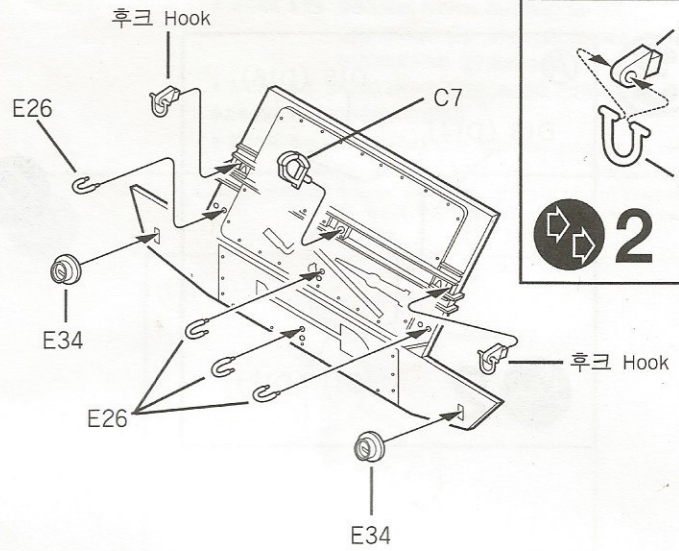
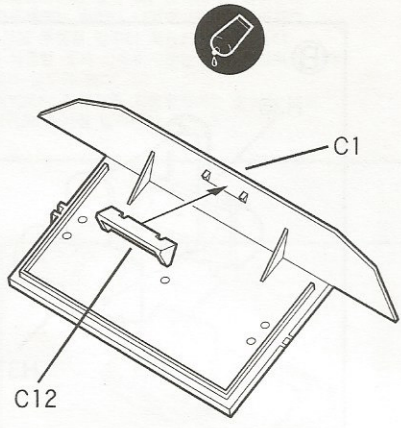

서포트 롤러
Support Roller

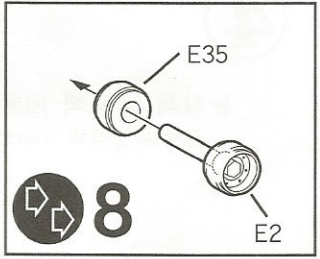

6

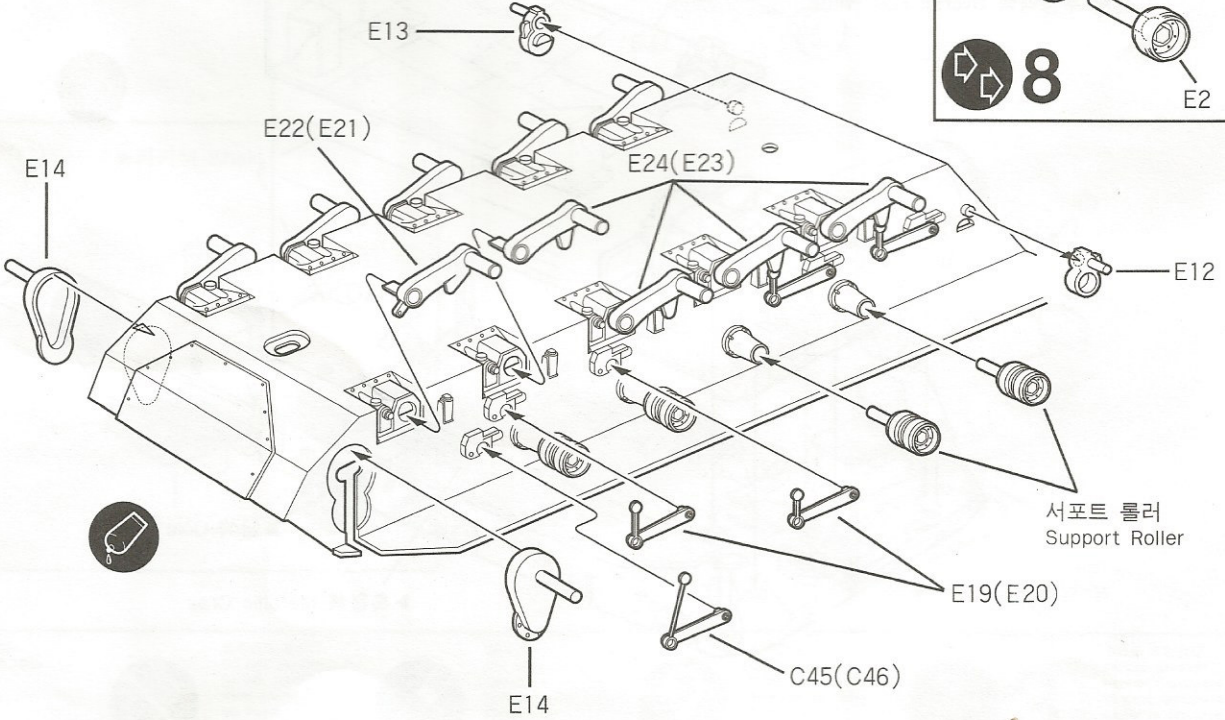

서포트 롤러
Support Roller

7

① 전륜 Road Wheel

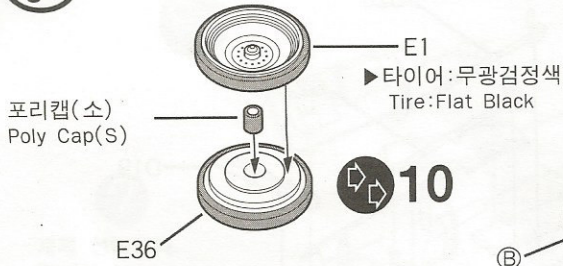

② 아이들러 휠 Idler Wheel

2

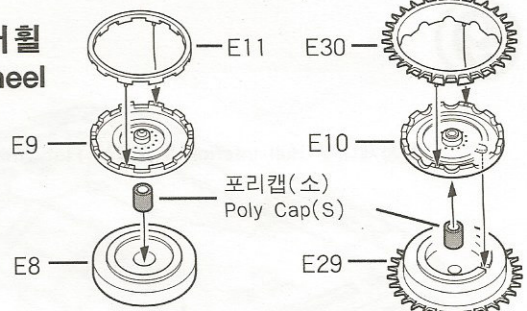

③ 기동륜 Drive Sprocket

2

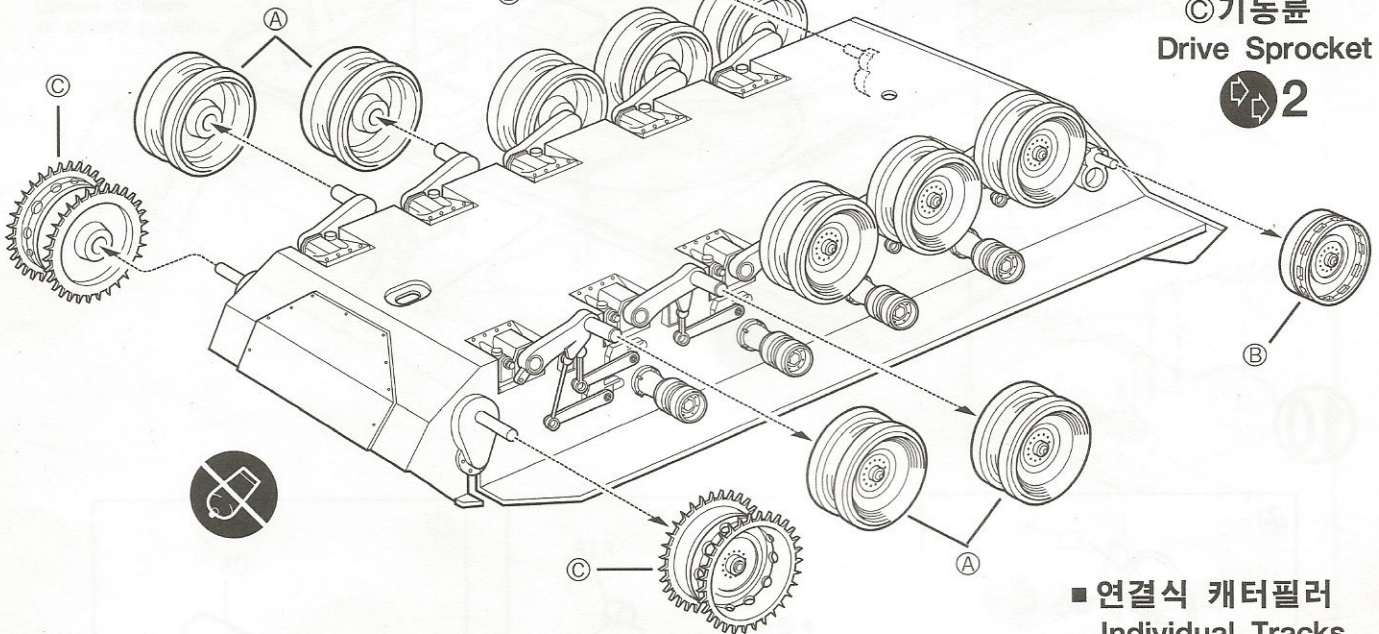

■ 연결식 캐터필러 Individual Tracks

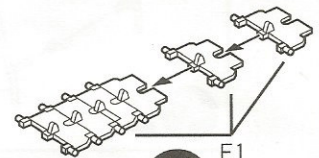

8

■ 연결캐터필러 Flexible Tracks

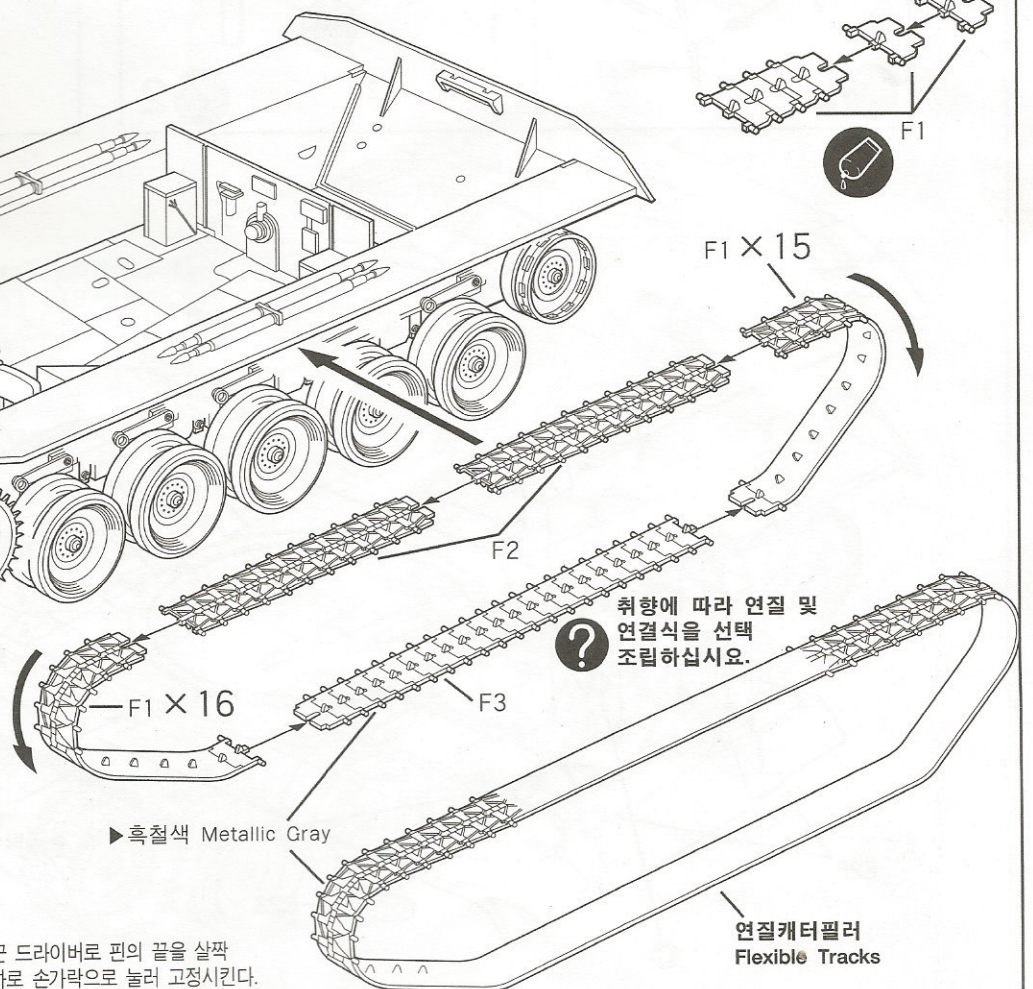
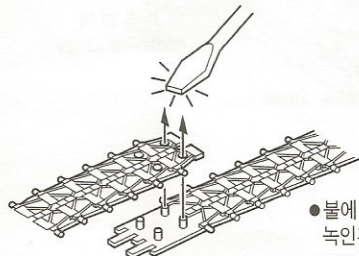

9

▶차체내부 Hull Interior:무광백색 Flat White

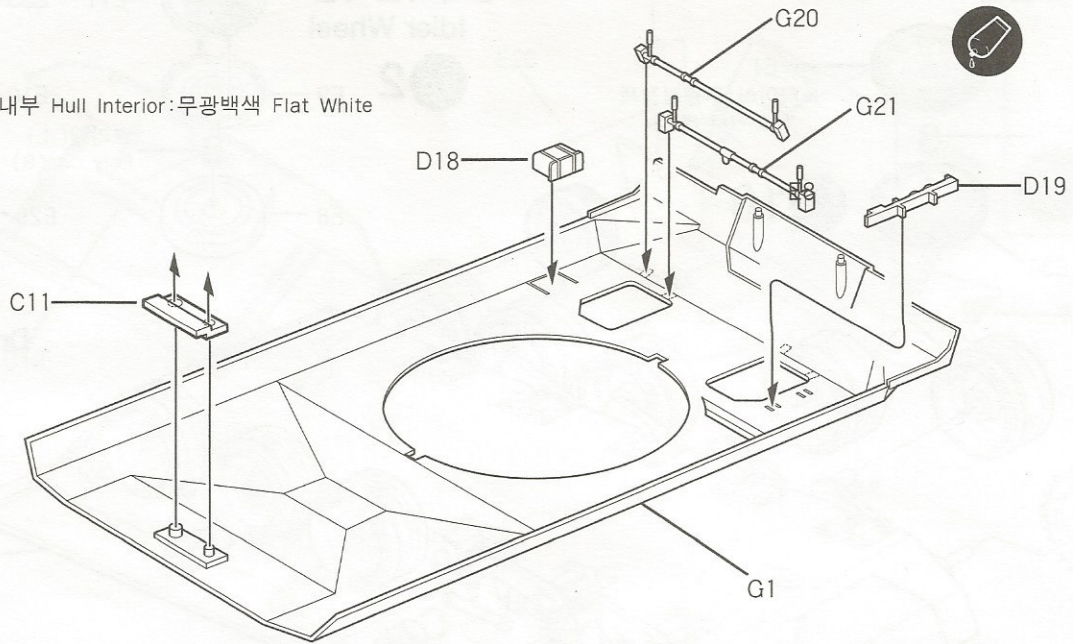

10

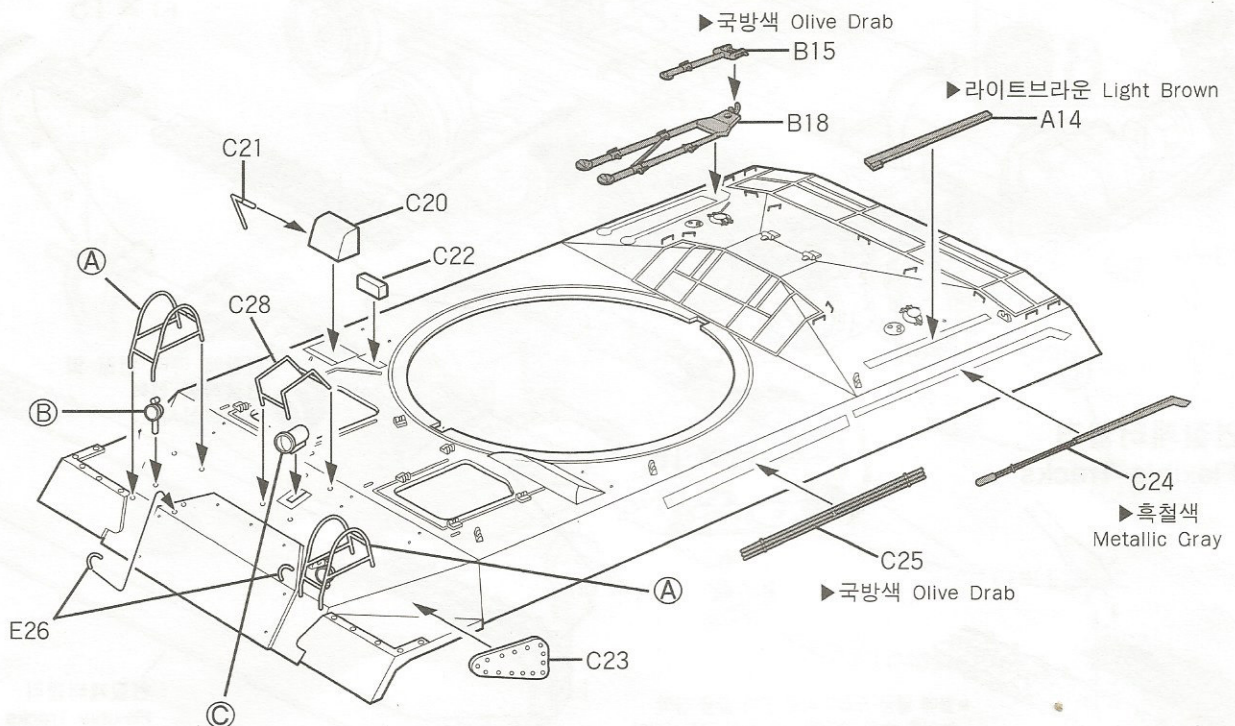
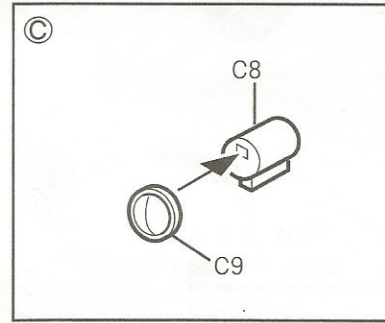
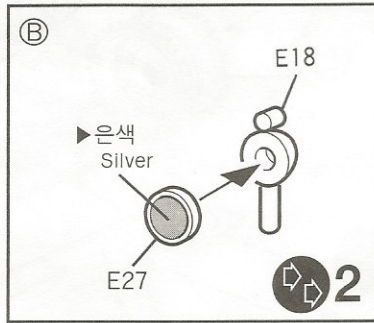
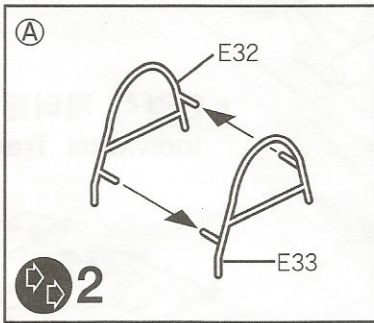

11

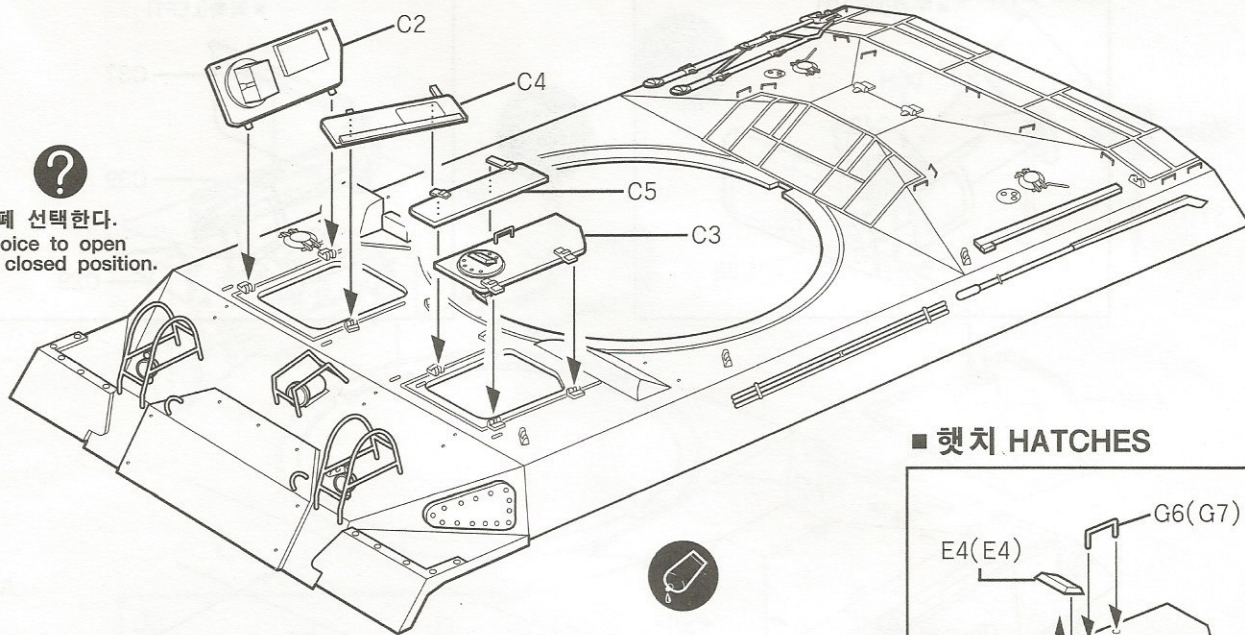

■ 햇치 HATCHES

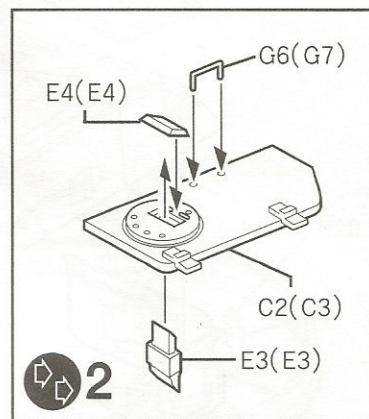

12

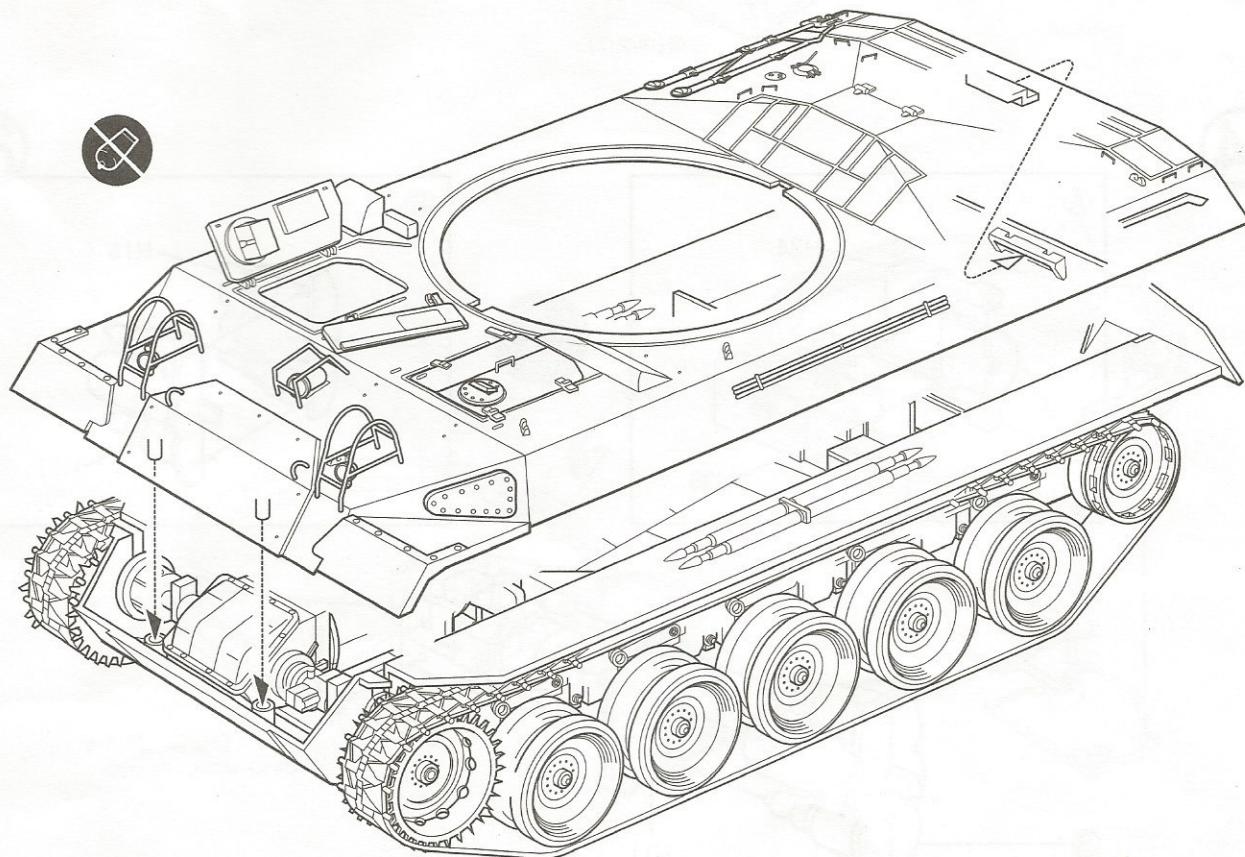

13

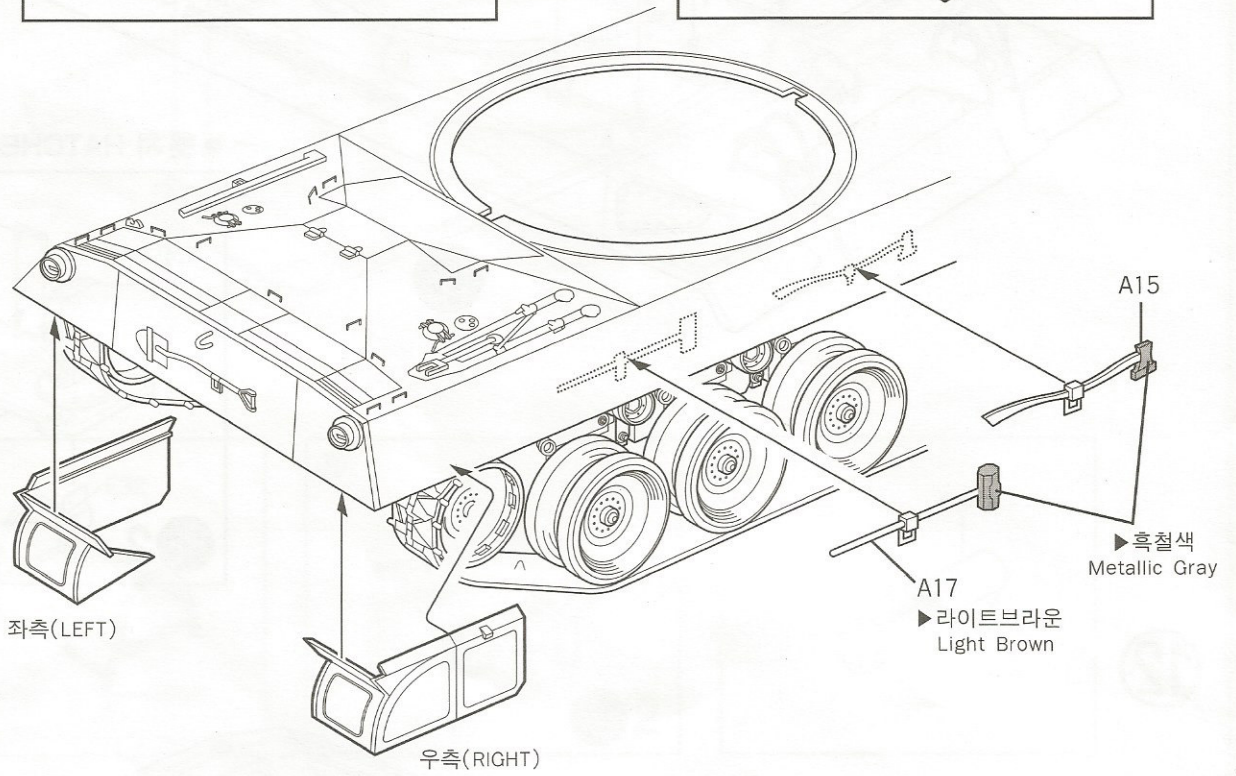
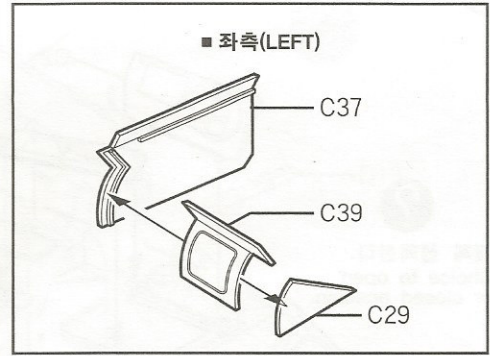
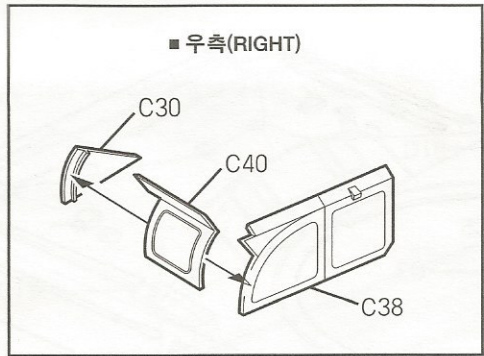

14

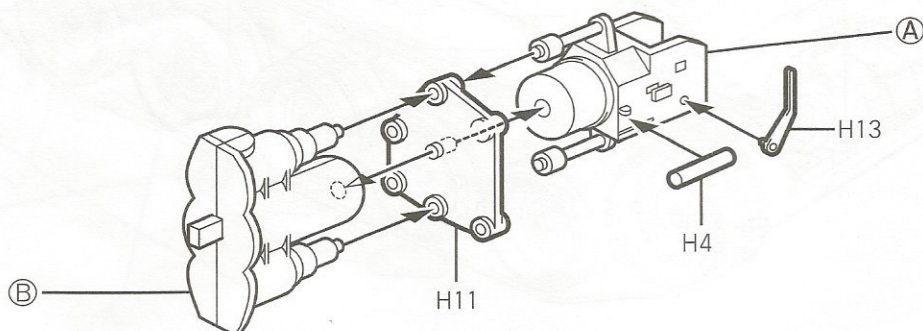
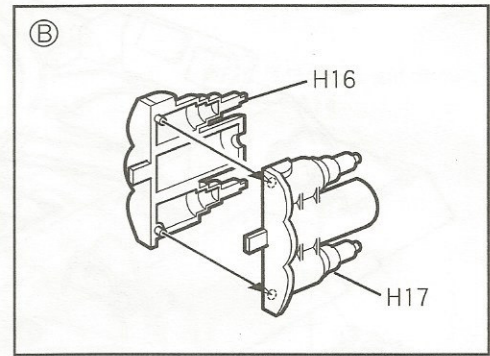
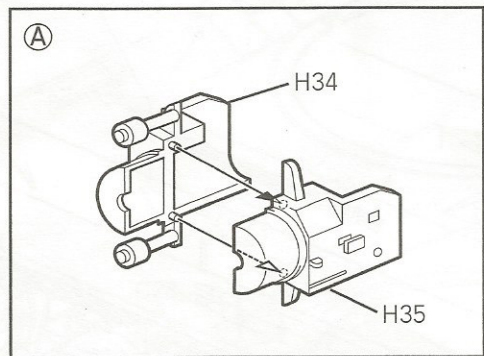

15

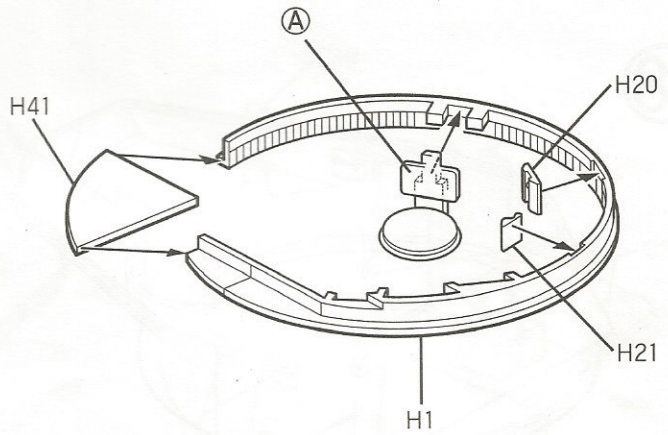
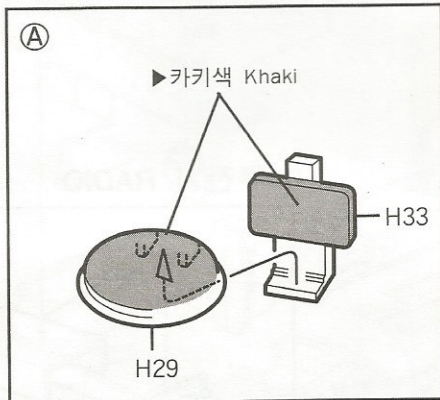
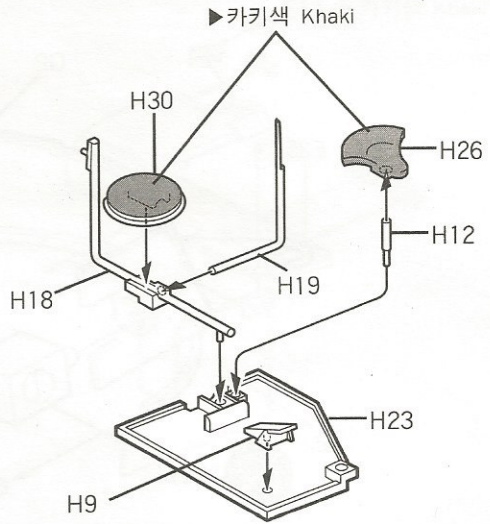
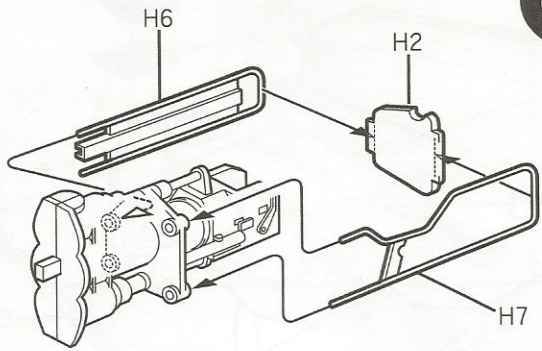

16

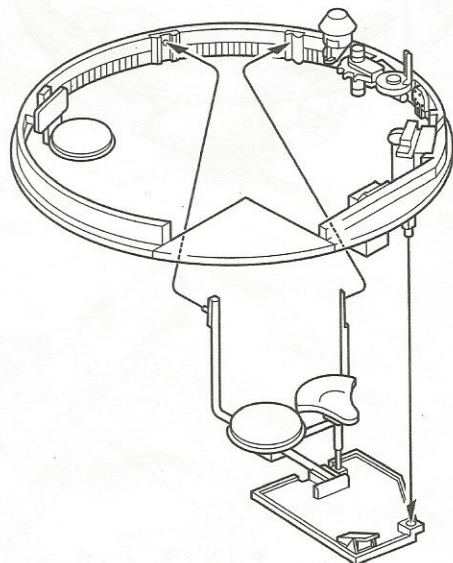
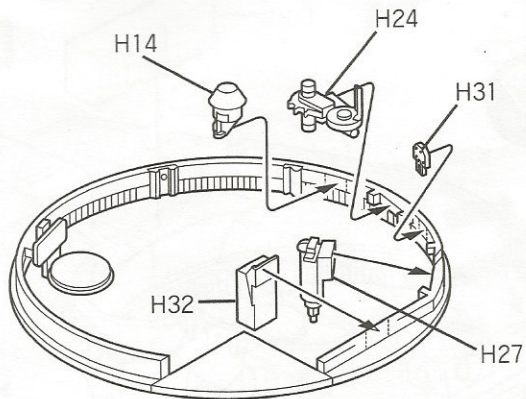

▶전체: 국방색
Overall: Olive Drab

17

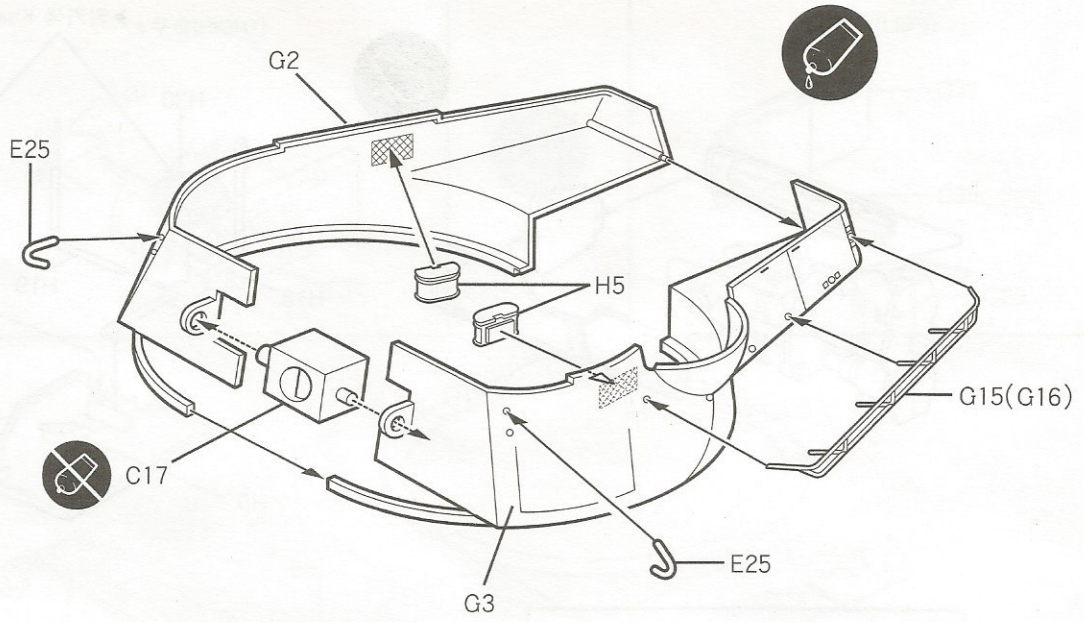

18

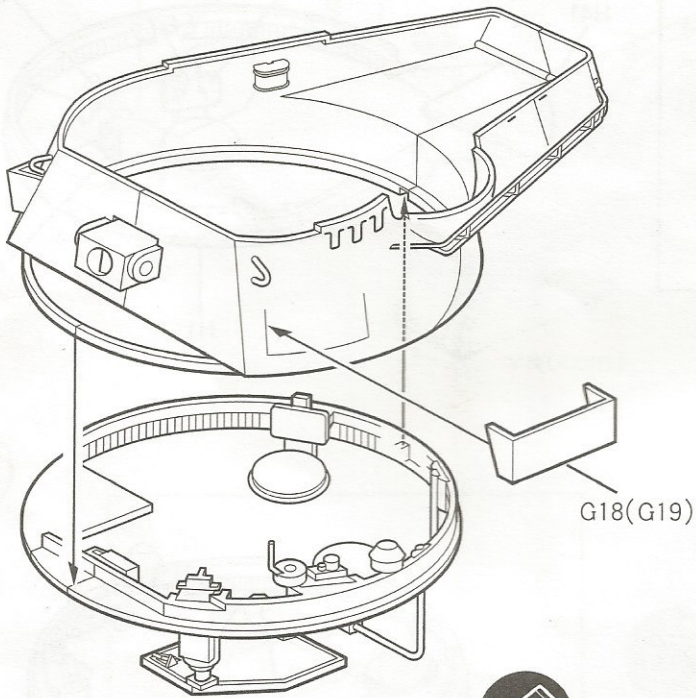

■ 무전기 RADIO

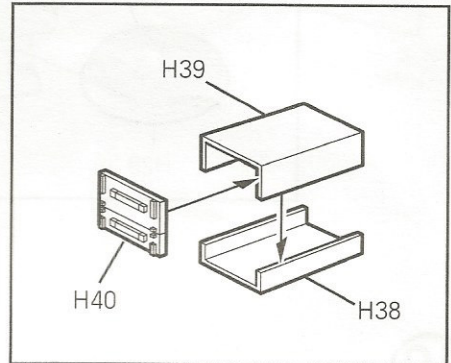

선택 조립한다.

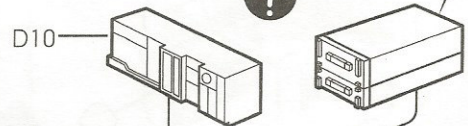

▶ 포탑내측: 국방색
Turret Interior: Olive Drab

▶ 카키색 Khaki

G4(G5)

19

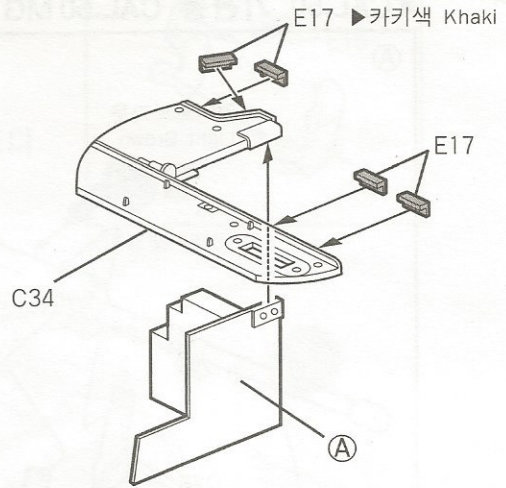
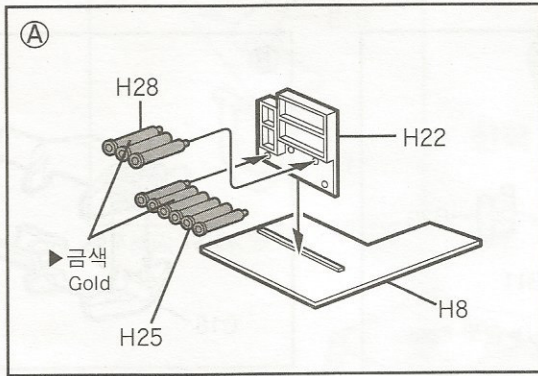

20

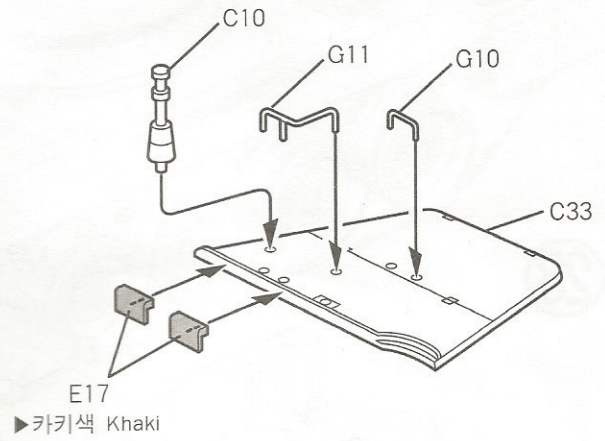
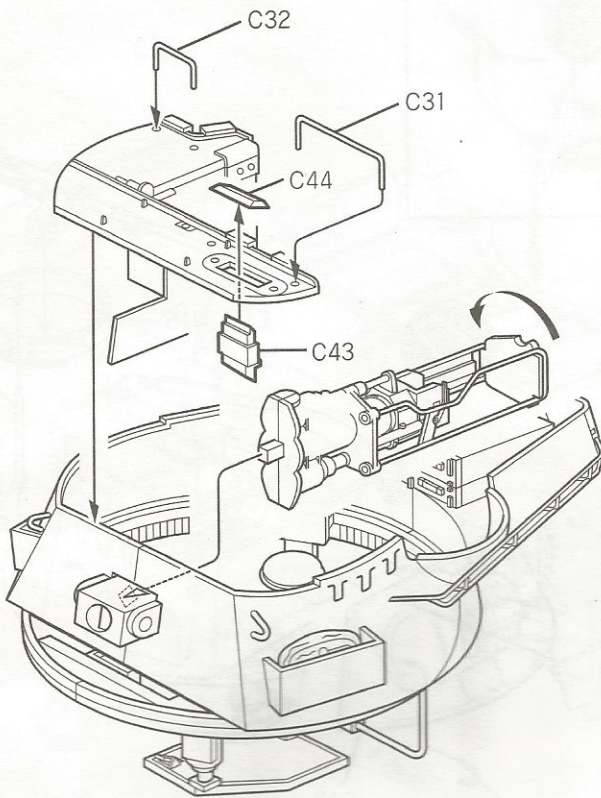

21

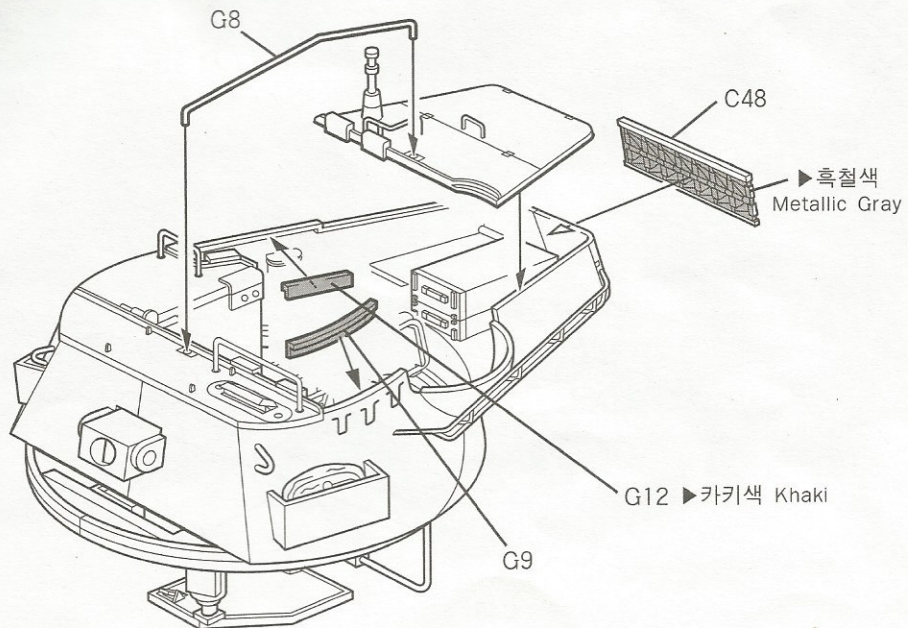

22

■ CAL.50 기관총 CAL.50 MG

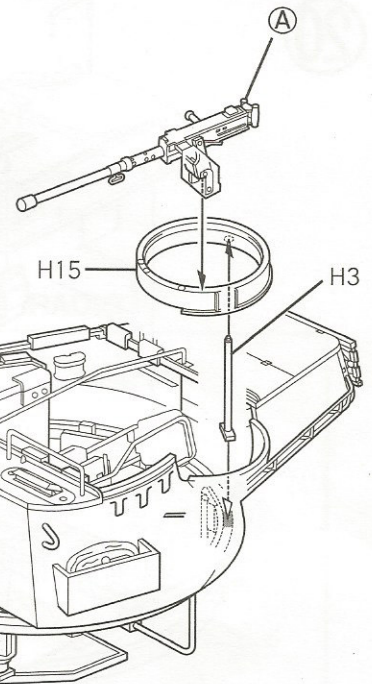
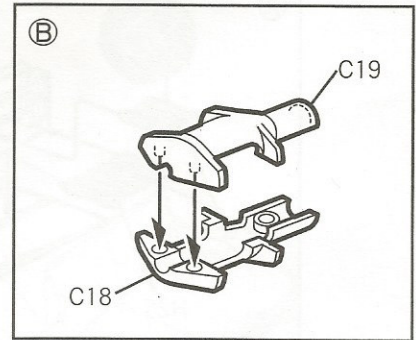
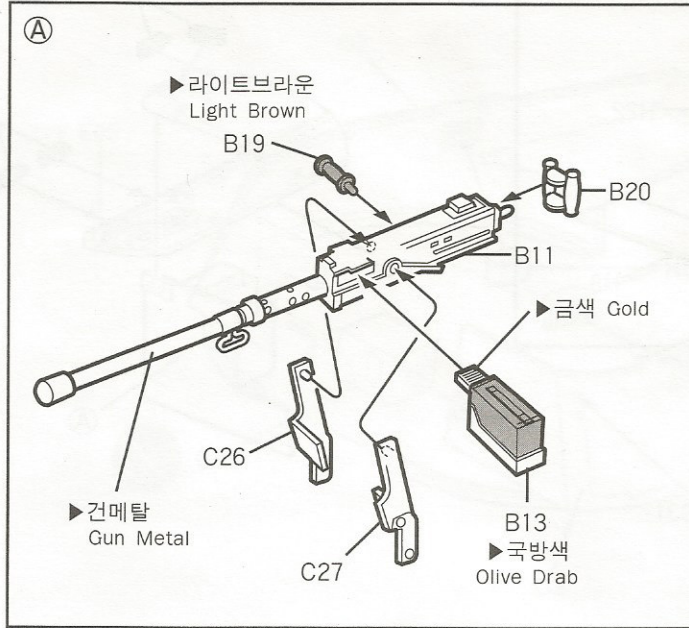

23

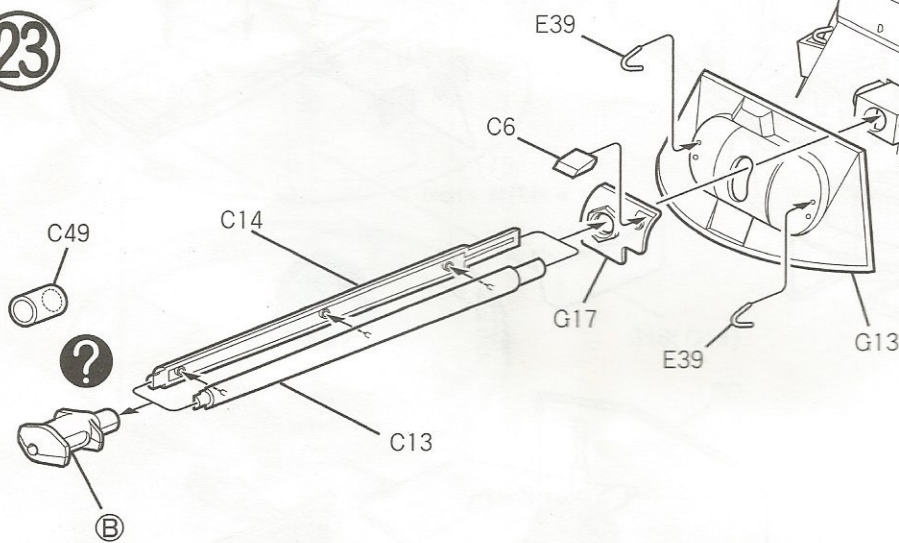

선택 조립한다.

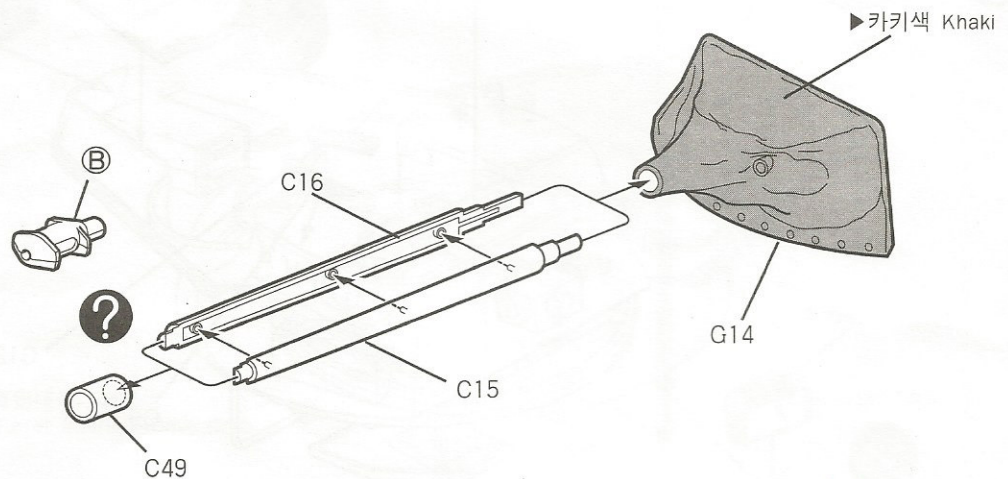

24

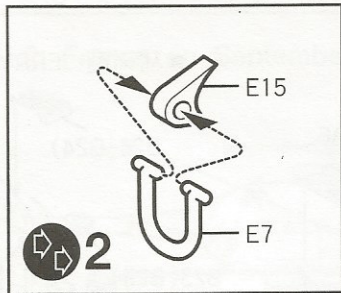

■ 후크 ㉠ HOOK ㉠



선택 조립한다.

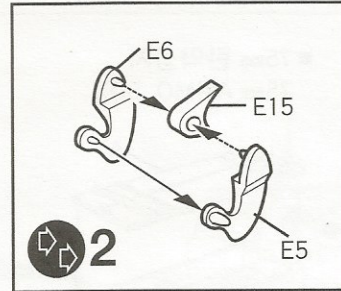

■ 후크 ㉡ HOOK ㉡

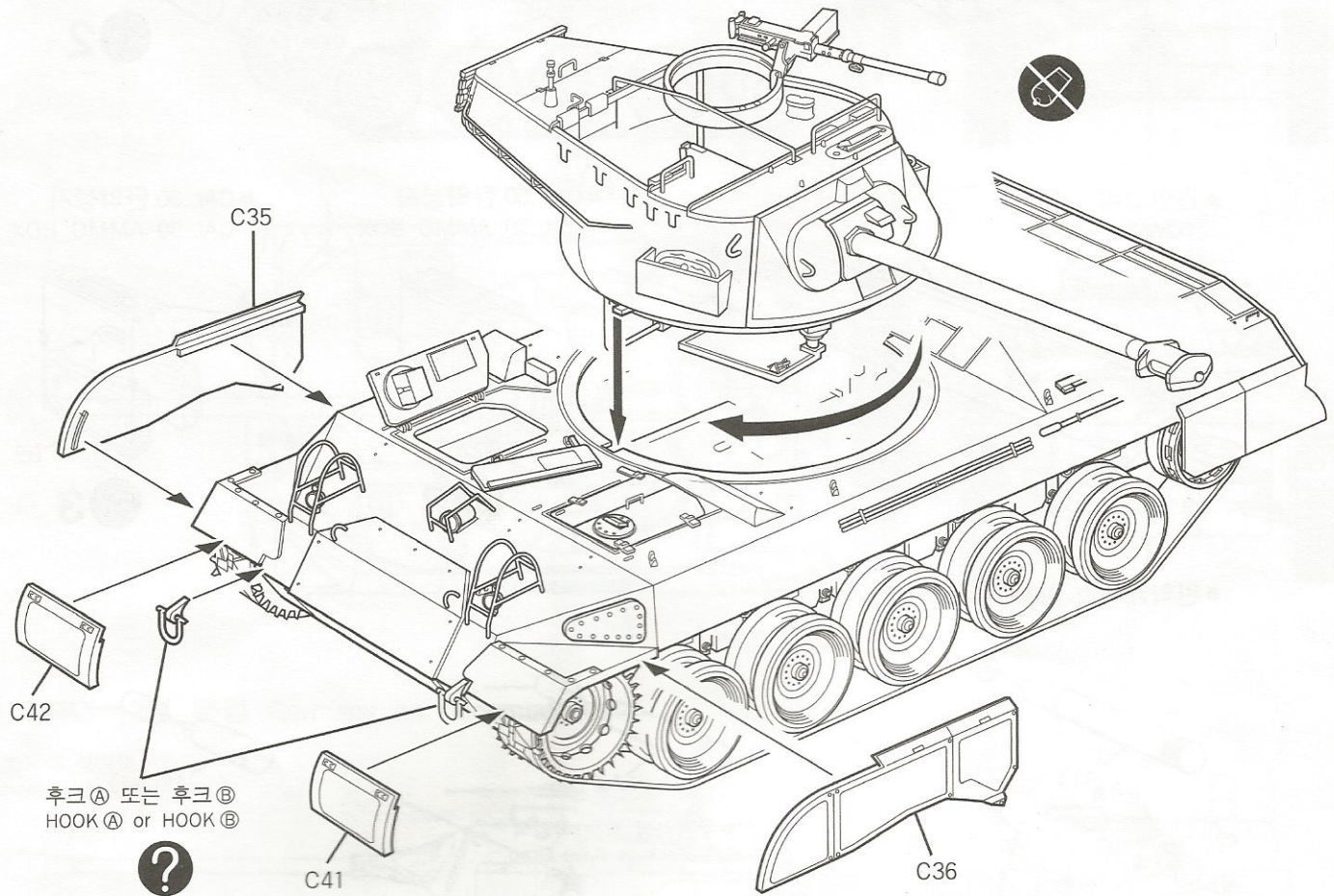

후크 ㉠ 또는 후크 ㉡
HOOK ㉠ or HOOK ㉡

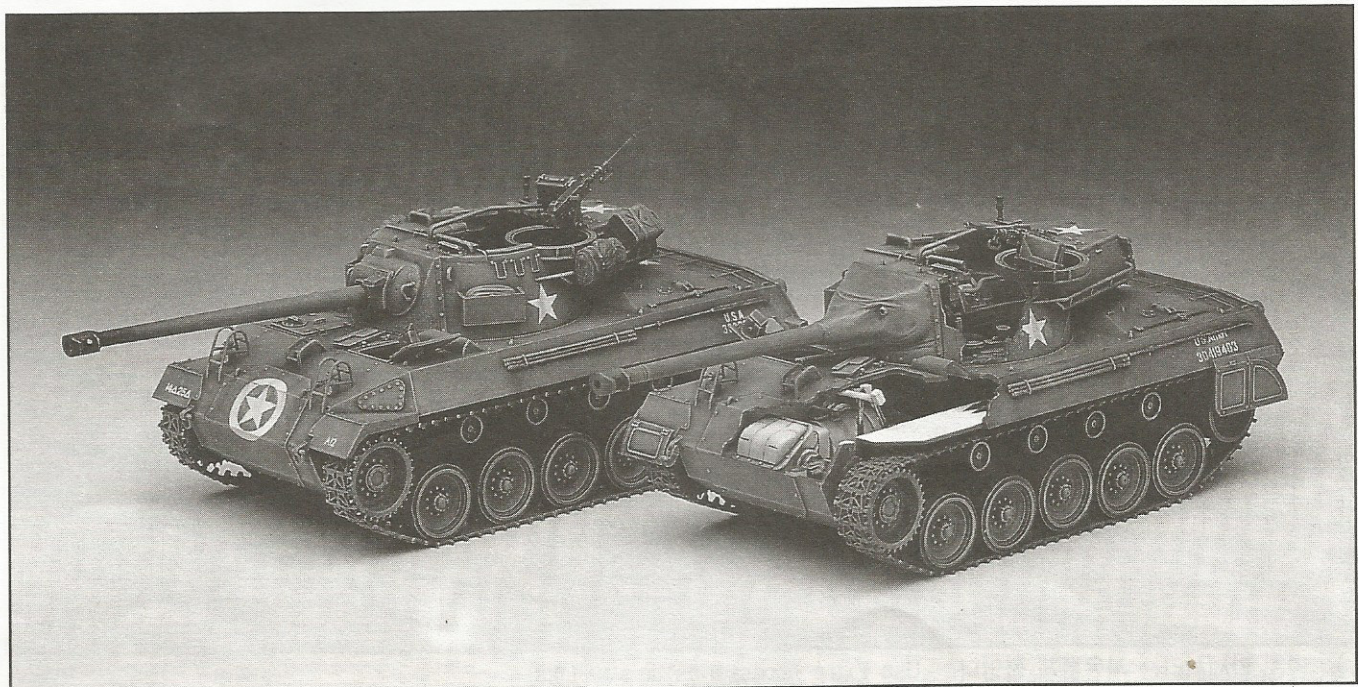

■ 75mm 탄약상자
75mm AMMO BOX

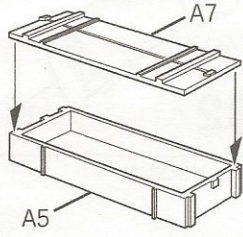

■ 76mm 탄약상자
76mm AMMO BOX

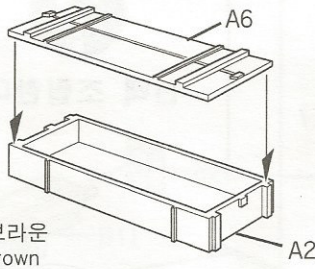

▶ 라이트브라운
Light Brown

■ 제리캔 JERRY CAN

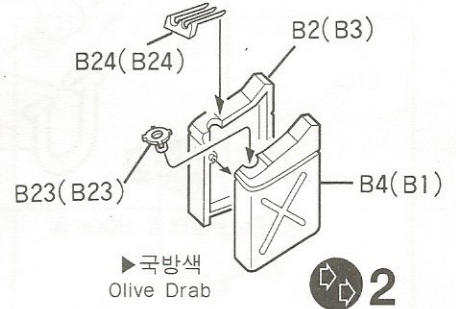

▶ 국방색
Olive Drab



■ 견인고리
TOWING HOOK

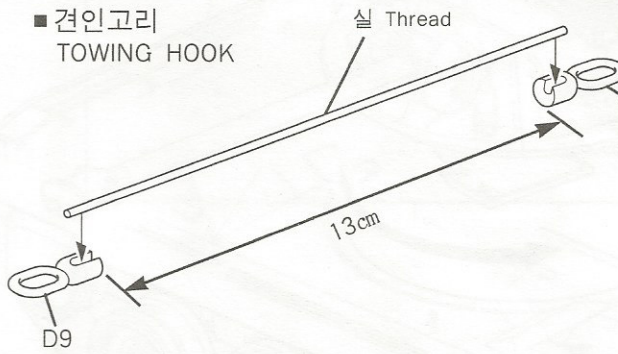

■ CAL.50 탄약상자
CAL.50 AMMO BOX

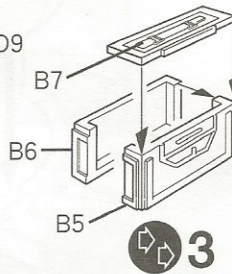

■ CAL.30 탄약상자
CAL.30 AMMO BOX

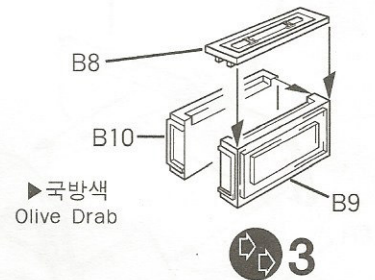

▶ 국방색
Olive Drab



■ 탄약케이스 AMMO TUBES

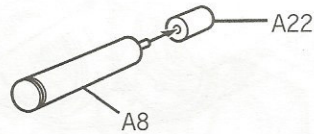
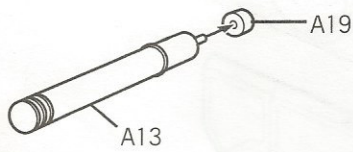

▶ 무광검정 또는 국방색
Flat Black or Olive Drab

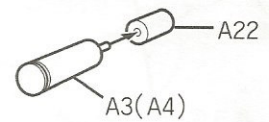

※ 남은 악세서리는 자유롭게 붙인다. Use Extra Accessories as you Like.

색칠 및 전사지 붙이기(Painting and Decal Placement)

■ 1944년 9월 프랑스 France on September 1944

■ 차체색:국방색
Body Color:Olive Drab

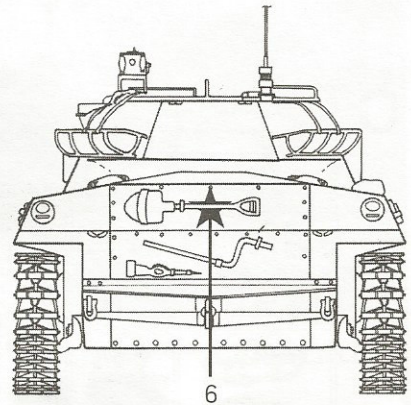
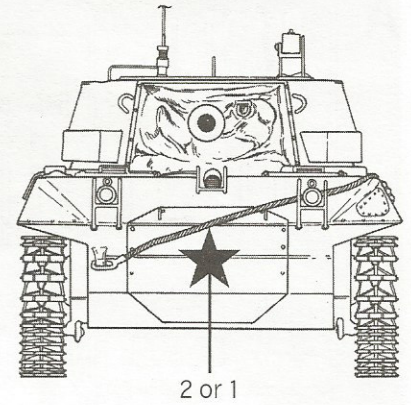
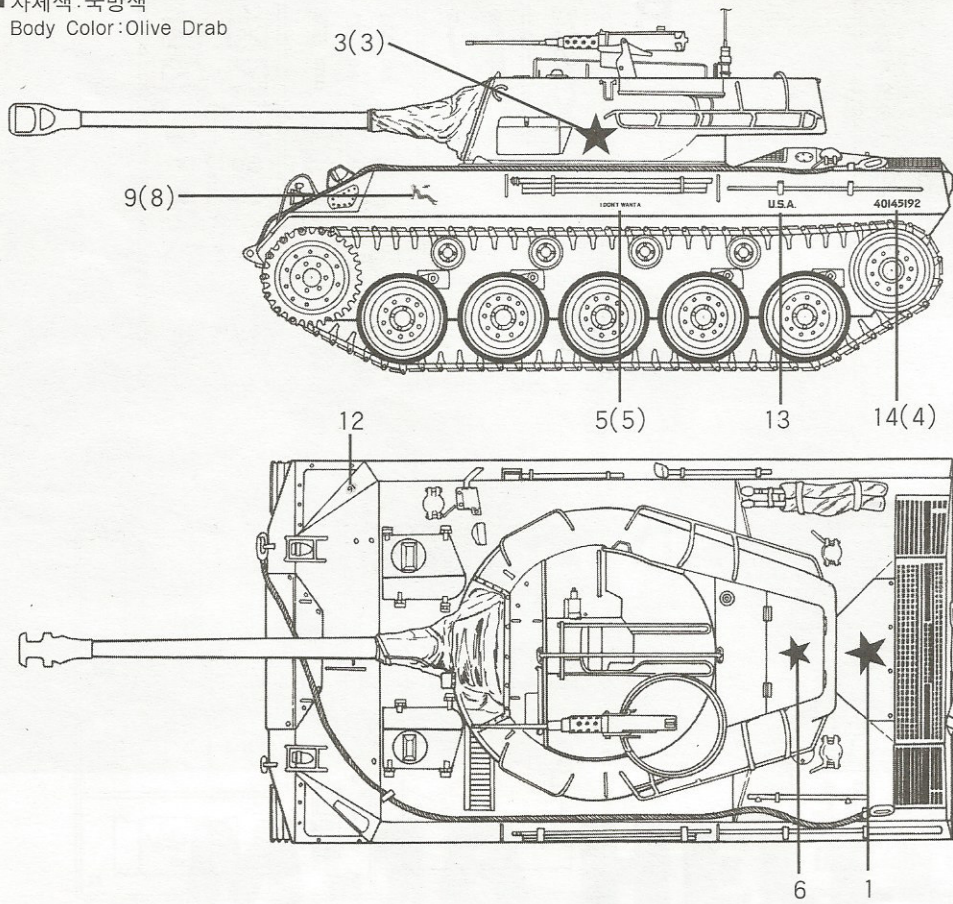

■ 1944년 12월 독일 Germany on December 1944

■ 차체색:국방색
Body Color:Olive Drab

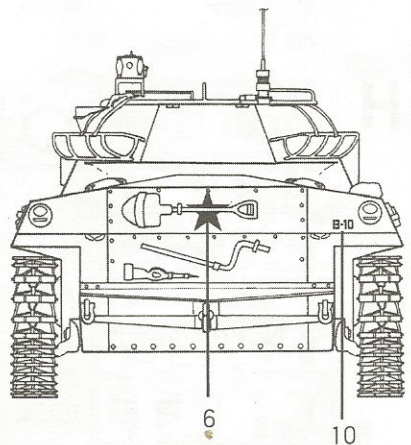
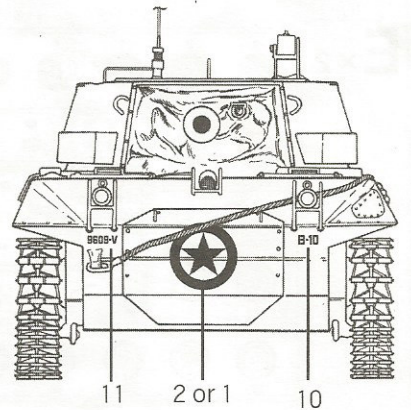
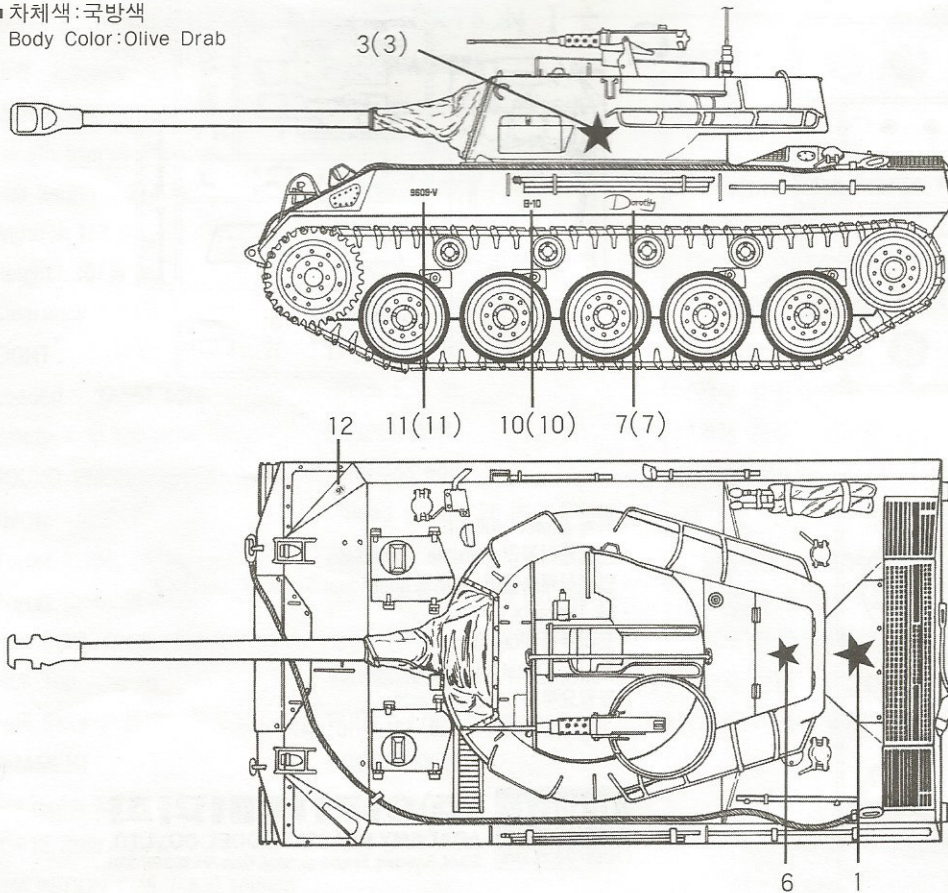

부품도 Parts Locating Diagram

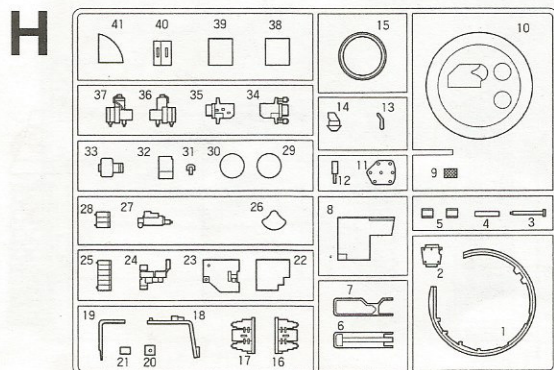
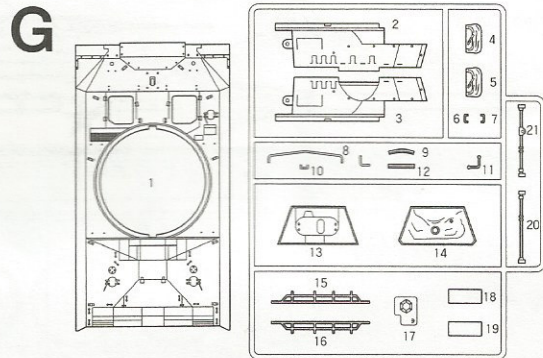
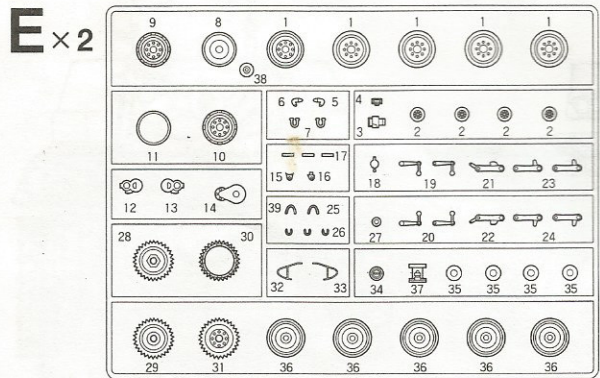
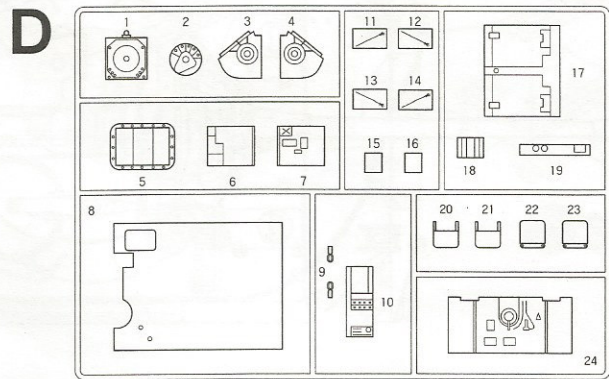
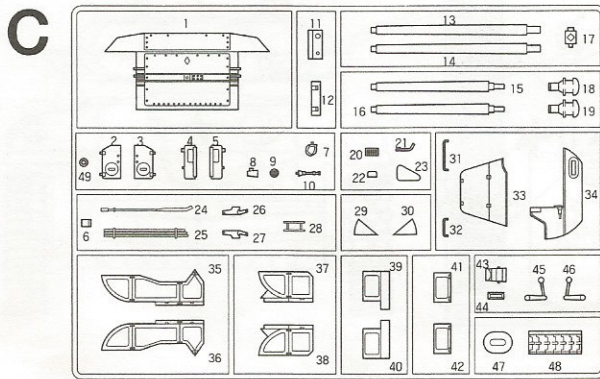
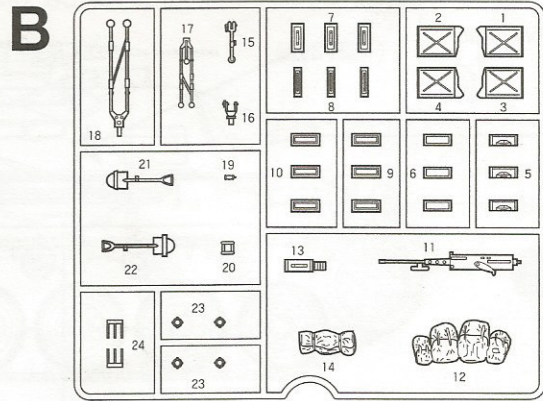
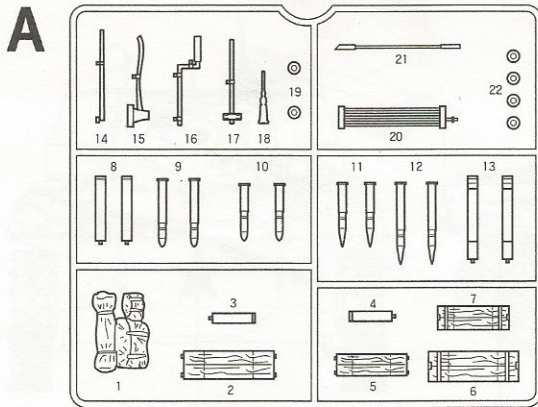

- 하체 Lower Hull × 1
- 연질캐터필러 Flexible Track × 2
- 연결식캐터필러 (F부품) Individual Tracks (F part) × 2
- 실 Thread × 1
- 폴리부품 Poly Cap × 1
- 전사지 Decal × 1
- ※ 불필요부품 Unused Parts
E21 × 1, E22 × 1, E28, E31, H10, C47

ACADEMY (주) 아카데미과학
ACADEMY PLASTIC MODEL CO., LTD.
 HOBBY MODEL KITS 273-64, Suyu-dong, Kangbuk-gu, Seoul, Korea ☎AX.82-2-997-3003