



1:48 Bristol Blenheim Mk.I

A09190 SCALE MODEL CONSTRUCTION KIT | Wingspan: 357mm Fuselage Length: 258mm | Two Decal Schemes Included

EN The first of the Bristol Blenheim series of light bombers flew as early as 1935 after Lord Rothermere had challenged the British aircraft industry to build a high speed transport plane. Rothermere had been concerned by contemporary German high-speed designs and so had asked the British industry to build a design to compete. Bristol already had a suitable machine on the drawing board and the Type 142 was nicknamed 'Britain First' and flew on the 12th of April 1935. The Air Ministry ordered the bomber version of the type straight from the drawing board, with 'Britain First' serving as the only prototype. Capable of speeds comparable to the biplane fighters of the day the Blenheim seemed a modern machine but by the outbreak of the Second World War fighter development had rendered the Blenheim vulnerable. First seeing service in France the Blenheim Mk.I was defended by just a single machine gun in the turret and a fixed machine gun in the wing. While later versions of the Mark IV featured twin turret guns as well as a ventral turret under the nose the Blenheim was always vulnerable to enemy fighter attack. The later Mark IV also introduced a radically different nose, giving the bombardier more room, but otherwise the basic design remained unchanged. The Blenheim served across the globe, fighting both in Europe, North Africa

and in the Far East during the unsuccessful defence of Malaya and Singapore. The Blenheim was a versatile machine, even pressed into service as a heavy fighter with an underbelly arrangement of 4 machine guns but it was often outclassed by the enemies it came up against. Today a handful of Benheims survive in museums, proud testaments to the men who flew and fought in them.

Specification

Maximum Speed: 265 mph (426km/h)

Wingspan: 56 ft 4 in (17.17m)

Length: 39 ft 9 in (12.1 m)

Armament: one fixed .303in machine gun in port wing, one .303in machine gun in dorsal turret. Up to 1,000lb of bombs or 4 x .303 machine guns in belly pack (1F only).

FR Le prototype de la série Bristol Blenheim de bombardiers légers effectua son premier vol en 1935. Le lord Rothermere avait défié l'industrie de l'aviation britannique de construire un avion de transport à grande vitesse car les designs allemands de l'époque dans ce secteur l'avaient incité à demander à l'industrie britannique de concevoir un appareil concurrentiel. La société Bristol disposant déjà d'un avion approprié à l'étude, le type 142 surnommé Britain First prit l'air le 12 avril 1935 en tant que seul prototype et le ministère de l'Air passa commande pour la version bombardier directement de la planche à dessin. Capable de vitesses comparables à celles des chasseurs bimoteurs contemporains, le Blenheim semblait être un appareil moderne mais lors du déclenchement de la Deuxième Guerre mondiale, les améliorations des avions de chasse l'avaient rendu vulnérable. Tout d'abord en service en France, l'armement défensif du Blenheim Mk.I n'avait qu'une seule mitrailleuse en tourelle et une mitrailleuse fixe dans la voilure. Même si les versions ultérieures du Mk.IV étaient munies d'un jumelage de mitrailleuses monté dans une tourelle ainsi qu'une tourelle ventrale sous le nez, le Blenheim était toujours vulnérable aux attaques des chasseurs ennemis. Le nez du Mk.IV fut également beaucoup modifié pour lui donner plus d'espace mais la construction de base restait inchangée. Le Blenheim était en service dans le monde entier,

et compris lors des combats en Europe, en Afrique du Nord et en Extrême-Orient pendant la défense échouée de la Malaisie et de Singapour. Avion polyvalent, il fut même mis en service comme chasseur lourd muni de quatre mitrailleuses ventrales mais il se révéla souvent surclassé par ses adversaires. De nos jours, quelques Blenheim ont survécu dans des musées, fiers témoins des équipages qui les avaient pilotés au combat.

Spécification:

Vitesse maximale: 426 km/h

Envergure: 17,17 m

Longueur: 12,1 m

Armement: une mitrailleuse fixe de 7,7 mm dans l'aile gauche, une mitrailleuse de 7,7 mm en tourelle dorsale. Jusqu'à 455 kg de bombes ou 4 mitrailleuses de 7,7 mm installées dans une soute ventrale (version 1F seulement).

DE Das erste der später zur Reihe Bristol Blenheim gehörigen leichten Bombenflugzeuge hob zum ersten Mal bereits 1935 ab, nachdem der Zeitungsmagnat Lord Rothermere die britische Flugzeugindustrie aufgefordert hatte, eine schnelle Transportmaschine zu bauen. Lord Rothermere war besorgt gewesen, dass deutschen Konstrukteuren zahlreiche Entwürfe für schnelle Flugzeuge gelungen waren; es wäre nun höchste Zeit für Großbritannien, Ähnliches zu bieten. Bei der Bristol Aeroplane Company war bereits ein passender Entwurf auf dem Reißbrett vorhanden. Dieser Typ 142 erhielt zunächst den Namen „Britain First“ und flog erstmals am 12. April 1935. Das britische Air Ministry bestellte auf dieser Grundlage eine Bomberversion, wobei die „Britain First“ bloß als Prototyp diente. Was ihre Geschwindigkeit betraf, war die Blenheim mit den damaligen Doppeldecker-Jagdflugzeugen durchaus vergleichbar. Als aber dann der Zweite Weltkrieg ausbrach, war sie aufgrund neuer Entwicklungen bei Jagdflugzeugen eher verwundbar geworden. Zuerst in Frankreich im Kampf eingesetzt, konnte sich die Blenheim Mark I nur mit einem einzigen kanzelmontierten Maschinengewehr und einem starr am Flügel angeordneten MG verteidigen. Während spätere Versionen der Mark IV mit kanzelmontierten Zwillings-MG wie auch einer unter der Nase befestigte MG-Kanzel ausgerüstet waren, blieb die Blenheim stets bei feindlichen Jägerangriffen in hohem Maße verwundbar. Die spätere Mark IV erhielt auch eine gänzlich neu gestaltete Nase. Damit stand dem Bombenschützen zwar mehr Raum zur Verfügung, doch blieb die Grundkonstruktion unverändert. Die

Blenheim wurde praktisch überall auf der Welt eingesetzt. Sie kämpfte in Europa, Nordafrika und auch bei der erfolglosen Verteidigung von Malaya und Singapur im Fernen Osten. Als in jeder Hinsicht vielseitige Maschine wurde die Blenheim sogar als schwerer Bomber verwendet. Trotz ihrer in dieser Rolle mit vier unter dem Rumpf angeordneten MG wurde sie jedoch oft von feindlichen Fliegern übertrumpft. Heute sind nur noch wenige Benheims in Museen vorhanden, wo sie bleibende Denkmäler für jene Besatzungen bilden, die sie flogen und mit ihnen kämpften.

Spezifikation:

Höchstgeschwindigkeit: 426 km/h

Spannweite: 17,17 m

Länge: 12,1 m

Bewaffnung: ein starr an der linken Tragfläche angeordnetes 7,7 mm MG; ein in einer Heckflossenkanzel angeordnetes 7,7 mm MG; Bombenlast bis 455 kg oder vier in einer Rumpfwanne angeordnete 7,7 mm MG (nur Typ 1F).

Airfix would like to thank, John 'Smudge' Smith and all at the Aircraft Restoration Company Duxford and all at the Finnish Air Force Museum at Tikkakoski <http://airforcemuseum.fi/>

FOR BEST RESULTS:

Surfaces to be painted should be clean — before parts are removed from the sprue, wash in warm, soapy water, rinse and dry thoroughly. Stir paints thoroughly before use.

PLEASE NOTE:

Some parts in the kit may not be required to build the model specified.

**HORNBY
HOBBIES**



ES Los primeros bombarderos ligeros de la serie Bristol Blenheim emprendieron el vuelo ya en 1935, tras el llamamiento de Lord Rothermere a la industria aeronáutica británica para construir un avión de transporte de alta velocidad. Rothermere se sentía preocupado por los diseños alemanes de la época, capaces de desarrollar velocidades muy elevadas, lo que le impulsó a pedir a la industria británica un aparato capaz de competir con ellos. Bristol ya disponía de un diseño en fase de proyecto: el Tipo 142 recibió el sobrenombre de 'Britain First' y realizó su primer vuelo el 12 de abril de 1935. El Ministerio del Aire realizó un pedido de la versión bombardero sobre la base del proyecto presentado y del 'Britain First' como único prototipo. Capaz de velocidades comparables a los cazas biplanos de la época, el Blenheim parecía un aparato moderno, pero al estallar la Segunda Guerra Mundial, los avances experimentados por los bombarderos habían convertido a los Blenheim en aviones vulnerables. Cuando entró en servicio en Francia, el único armamento defensivo del Blenheim Mk.I era una ametralladora en la torreta y otra ametralladora fija en el ala. Aunque las versiones posteriores del Mark IV contarían con doble ametralladoras en la torreta así como torreta ventral bajo el morro, el Blenheim siempre resultaba vulnerable a los ataques de los cazas enemigos. Los Mark IV posteriores también presentaban un morro radicalmente distinto, que aumentaba el espacio interior del bombardero. Por lo demás, el diseño básico se mantuvo sin

cambios. El Blenheim prestó servicio en todo el planeta, interviniendo en Europa, norte de África y Lejano Oriente, durante la infructuosa defensa de Malasia y Singapur. El Blenheim era un aparato muy versátil, que llegó incluso a entrar en servicio como bombardero pesado con cuatro ametralladoras en la parte inferior, aunque con frecuencia se veía superado por los aviones a los que hacía frente. En la actualidad sobrevive un puñado de Blenheim en distintos museos, como homenaje a los hombres que volaron y pelearon con ellos.

Especificación:

Velocidad máxima: 426 km/h

Envergadura: 17,17m

Longitud: 12,1 m

Armamento: una ametralladora fija de 7,7 mm en el ala de babor, una ametralladora de 7,7 mm en la torreta dorsal. Hasta 455 kg de bombas o 4 ametralladoras de 7,7 mm en la torreta ventral (solo IF).

SV Det första lätta bombplanet i Bristol Blenheim-serien flögs så tidigt som 1935 efter att Lord Rothermere hade uppmanat den brittiska flygindustrin till att bygga ett transportplan med hög hastighet. Rothermere var bekymrad över tyskarnas höghastighetsplan och önskade att britterna skulle skapa en design som kunde mäta sig med tyskarnas. Bristol hade redan en lämplig maskin på ritbordet, Type 142 med smeknamnet "Britain First" som flögs för första gången den 12 april 1935. Flygministeriet beställde en bombplansversion av typen direkt från ritbordet, vilket innebar att "Britain First" fick bli den första och enda prototypen. Blenheim, som nådde upp i liknande hastigheter som samtidigt jämförbara biplan, såg ut som en modern maskin men vid andra världskrigets utbrott visade sig Blenheim vara mycket särbart för samtidigts jaktplan. Blenheim Mk.I, som först användes i Frankrike, hade endast en kulspruta i kulsprutetornet och en fast kulspruta i vingen. Senare versioner av Mark IV hade två kulsprutor samt ett extra torn under nosen, men Blenheim var fortfarande särbart för fiendens jaktplansattacker. Den senare Mark IV-varianten uppvisade en helt ny nos som gav bombfällaren mer plats, men i övrigt var designen ungefär densamma. Blenheim användes världen över, inklusive i Europa, Nordafrika och Fjärran östern under

det misslyckade försaret av Malaya och Singapur. Blenheim var en mångsidig maskin som även användes som tungt jaktplan med fyra kulsprutor under buken, men det utklassades ofta av de fiendeplan det ställdes inför. Idag finns några få Blenheim-plan kvar på museum som stolta påminnelser om de män som flög och kämpade i dem.

Spekifikation:

Maximal hastighet: 426 km/h

Spännvidd: 17,17 m

Längd: 12,1 m

Bestyckning: en fast 7,7 mm-kulspruta i vingen, en 7,7 mm-kulspruta i ryggtornet. Upp till 455 kg bomber eller fyra 7,7 mm-kulsprutor på undersidan (endast IF).

ASSEMBLY INSTRUCTIONS

EN Study drawings and practise assembly before cementing parts together. Carefully scrape paint from cementing surfaces. All parts are numbered. Paint small parts before assembly. To apply decals cut sheet as required, dip in warm water for a few seconds, slide off backing into position shown. Use in conjunction with box artwork. Not appropriate for children under 36 months of age, due to the presence of small detachable parts.

FR Étudier attentivement les dessins et simuler l'assemblage avant de coller les pièces. Gratter soigneusement toute peinture sur les surfaces à coller. Toutes les pièces sont numérotées. Peindre les petites pièces avant l'assemblage. Pour coller les décalcomanies, découper le motif, le plonger quelques secondes dans de l'eau chaude puis le poser à l'endroit indiqué en décollant le support papier. Utiliser conjointement avec les illustrations sur la boîte. Ne convient pas aux enfants de moins de 36 mois - présence de petits éléments détachables.

DE Vor dem Zusammenkleben der Teile die Zeichnungen sorgfältig ansehen und die zu verklebenden Teile zur Vermeidung möglicher Fehler versuchsweise zusammenfügen. Dann an den Klebeflächen vorhandene Farbbeschichtung vor dem Zusammenkleben vorsichtig abkratzen. Alle Bestandteile sind mit Nummern versehen. Kleine Teile vor dem Zusammenbau bemalen. Abziehbilder wie gewünscht ausschneiden. Vor dem Anbringen einige Sekunden in warmes Wasser tauchen und dann vom Trägerpapier in ihre vorgesehene Position schieben. Dabei die Abbildungen auf der Schachtel beachten. Nicht für Kinder unter 36 Monaten geeignet, da abnehmbare bzw. lose angebrachte Kleinteile enthalten sind.

ES Estudiar los dibujos y practicar el montaje antes de pegar las piezas. Raspar cuidadosamente la pintura en las superficies de contacto antes de pegar las piezas. Todas las piezas están numeradas. Es conveniente pintar las piezas pequeñas antes de su montaje. Para aplicar las calcomanías, cortarlas de la hoja, sumergirlas en agua tibia durante unos segundos y deslizarlas a la posición indicada. Utilizar en conjunción con la ilustración de la caja. No es adecuado para niños menores de 36 meses, ya que contiene piezas pequeñas que podrían soltarse.

SV Studera bilderna noggrant och sätt ihop delarna innan du limmar ihop dem. Skrapa försiktigt bort färg från limmade delar. Alla delarna är numrerade. Måla smådelarna före ihopsättning. Sätt fast dekalerna genom att klippa arket, doppa i varmt vatten några sekunder och låta baksidan glida på plats som bilden visar. Använd enligt bildanvisningarna på kartongen. Rekommenderas ej för barn under 3 år. Innehåller löstagbara smådelar.

NL Tekeningen bestuderen en delen in elkaar zetten alvorens deze te lijmen. Lak voorzichtig van lijmvlakken afschrapen. Alle delen zijn genummerd. Kleine delen vóór montage verven. Voor aanbrengen van stickers, gewenste stickers uit het vel knippen, een paar seconden in warm water dompelen en dan van het schutblad af op afgebeelde plaats schuiven. Hierbij afbeelding op doos raadplegen. Niet geschikt voor kinderen onder 3 jaar, omdat kleine deeltjes gemakkelijk kunnen losraken.

PO Przed przystąpieniem do sklejania przestudiuj uważnie rysunki i przedwzrost składowanie części. Ostrożnie zeskrubuj ze sklejalnych powierzchni farbę. Wszystkie części są ponumerowane. Drobnie części pomaluj przed ich złożeniem. Ciepłym przemieszaniem kalkomanii wytnij ją z arkusza, zanurz na kilka sekund w ciepłej wodzie i wsuń z podłoża na wymagane miejsce. Używaj w połączeniu ze wzorami na pudełku. W związku z obecnością wielu drobnych, rozbielanych części, nieodpowiednie dla dzieci poniżej 3 lat.

IT Studiare i disegni ed esercitarsi a montare i vari pezzi prima di fissarli con la colla. Raschiare con cura le tracce di vernice dalle superfici da incollare. Tutti i pezzi sono numerati. Verniciare i pezzi di piccole dimensioni prima di montarli. Per applicare le decalcomanie, ritagliare il foglio nel modo richiesto, immergere in acqua calda per alcuni secondi, quindi staccare la decalcomania dalla carta di supporto e posizionarla nel punto desiderato. Usare le decalcomanie come indicato nell'illustrazione riportata sulla confezione. Non adatto a bambini di età inferiore a 36 mesi per la presenza di componenti di piccole dimensioni che potrebbero staccarsi.

PT Estudar atentamente os desenhos e experimentar a montagem. Raspar cuidadosamente as superfícies de modo a eliminar pintura antes de colar. Todas as peças estão numeradas. Pintar as pequenas peças antes de colar. Para aplicar as decalcomanias, cortar as folhas e mergulhar em água morna por alguns segundos, depois deslizar e aplicar no respectivo lugar, como indicado nas ilustrações na caixa. Não convém a uma criança de menos de 36 meses devido à presença de pequenos elementos destacáveis.

EL Μελετήστε προσεκτικά τα σχέδια και συναρμολογήστε για πρώτη φορά τα κομμάτια χωρίς να τα συγκολλήσετε. Αφαιρέστε επιμελώς την πλαστική βαφή από τις επιφάνειες τις οποίες θα συγκολλήσετε. Όλα τα κομμάτια είναι αριθμημένα. Χρωματίστε τα μικρά κομμάτια πριν από τη συναρμολόγηση. Για να κολλήσετε τις χαλκομανίες, κόψτε γύρω από το σχέδιο όπως απαιτείται, βυθίστε το μερικά δευτερόλεπτα σε χλιαρό νερό και μετά τοποθετήστε το στη θέση που υποδεικνύεται, αφαιρώντας τη μεμβράνη που το καλύπτει. Λάβετε υπόψη σας ταυτόχρονα την επικοινωνία της του κουτιού. Ακατάλληλο για παιδιά ηλικίας κάτω των 36 μηνών λόγω ύπαρξης μικρών κομματιών που αποσπούνται.

FI Tutustu piirroksiin ja harjoittele kokoamista, ennen kuin liimast osat yhteen. Raaputa maali varovasti pois liimattavilta pinnolta. Kaikki osat on numeroitu. Maalaa pienet osat ennen kokoamista. Siirtokuvien kiinnittämisessä löikää ne arkista tarpeen mukaan. Kasta kuiva lämpimään veteen muutama sekunnin ajaksi, anna takapuolen liukua kuvalle osoitettuun kohtaan. Käytetään yhdessä laatikon kuvituksen kanssa. Ei suositella alle kolmivuotiaille lapsille. Paljon irrottettavia pikkusasia.

DA Studér tegningerne nøje og forsøg at sætte delene sammen, inden de klæbes sammen. Skrab forsigtigt malingen af de overflader, der skal klæbes sammen. Alle dele er nummererede. Små dele skal males, før de monteres. Overføringsbillederne påføres ved at klippe dem ud af arket, som påkrævet, dypp dem i varmt vand i nogle få sekunder, hvorefter underlaget glides af i de viste positioner. Påføres ifølge illustrationerne på æsken. Ikke egnet til børn under 3 år på grund af tilstedeværelse af små aftagelige dele.

ASSEMBLY ICON INSTRUCTIONS

 Assembly phase Phase de montage Montagephase Fase de montaje Monteringsfasen Fase di montaggio Montagefase Fase de montagem Monteringsfase Kokoamisvaihe Faza składowania Φάση συναρμολόγησης	 Cement Coller Kleben Pegar Limma Incollare Lijmen Colar Klebes Liimaa Kleić Συγκολλήστε	 Do not cement together No pas coller Nicht kleben No pegar Limma inte Non incollare Niet lijmen Nac colar Skal ikke klebes Alä liimaa Nie kleić Μη συγκολλήσετε	 Indicates final location Indique l'emplacement final Zeigt Endposition Indica la ubicación definitiva Anger slutmonteringsplats Sede di montaggio finale Geeft uiteindelijke locatie aan Indica localização final Viser endelig placering Osoittaa lopullisen sijainnin Oznacza miejsce docelowe Υποδεικνύει τελική τοποθεσία	 Alternative part(s) provided Autre(s) pièce(s) fournie(s) Ersatzteil(e) mitgeliefert Se incluye(n) pieza(s) alternativa(s) Alternativ(a) del(ar) ingår Uno o più componenti alternativi forniti Alternatieve onderdelen meegeleverd Peça(s) alternativa(s) fornecida(s) Alternativ(e) del(e) medfølger Vaihtoehtoiset osat pakkaussessa Dostęrne części zamiennie Παρέχονται εναλλακτικά κομμάτια	 Repeat this operation Répéter l'opération Vorgang wiederholen Repètir la operación Upprepa åtgärden Ripetere l'operazione De verrichting herhalen Repètr a operação Manoveren gentages Toista toimenpite Powtórzyć operację Επανάλάβετε τη διαδικασία
---	--	--	--	--	--

 Decals Décalcomanies Abziehbild Calcomanias Dekaler Decalcomanie Stickers Decalcomania Biledoverføring Siirtokuvat	 Crystal part Pièce cristal Kristallteil Pieza de cristal Kristalldel Pezzo cristallo Kristallen onderdeel Peça de cristal Kryształtyłke Krystallisa	 Weight Lesler Beschweren Lastar Belasta Applicare un peso Verzwaren Lastrar Påfør vægt Aseta vastainpaino	 Remove by filing Enlever avec une lime Abfeilen Abfeilen Eliminar con lima Ta bort genom att lima Rimuovere con la lima Verwijderen door afvijlen Removea limando Fjern ved at file vaak Prišta vilišampala	 Drill or pierce Percar Durchbohren Perforar Borra Trapanare o forare Boren of doorboren Furar Gennembor Pora tai puukausa	 Cut Découper Schneiden Cortar Skär Tagliare Snijden Cnijten Skær Humbrol-maalin numerot	 Humbrol paint number No peinture Humbrol Humbrol-Farbnummer No de pintura Humbrol Humbrol färg nummer No vernice Humbrol Humbrol verfunnummer No de pintura Humbrol Humbrol malingnummer Humbrol-maalin numerot
--	--	--	---	---	--	--

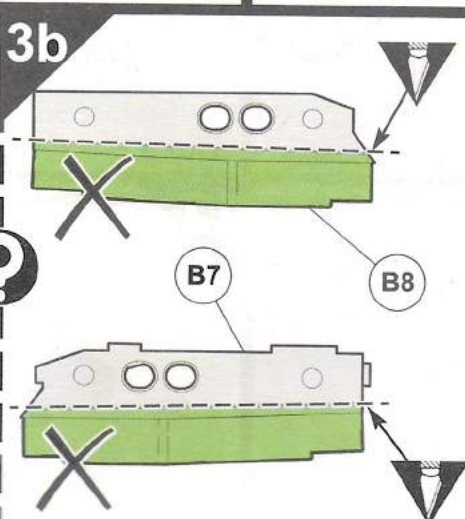
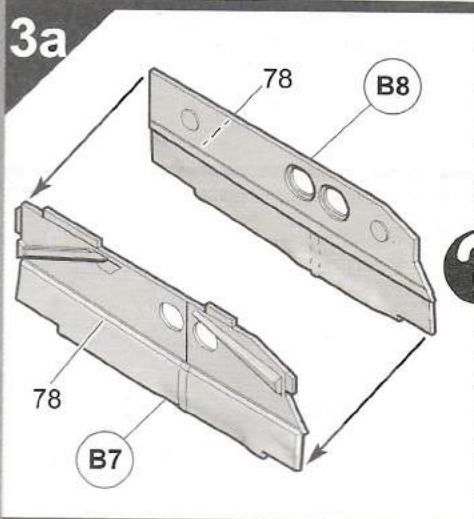
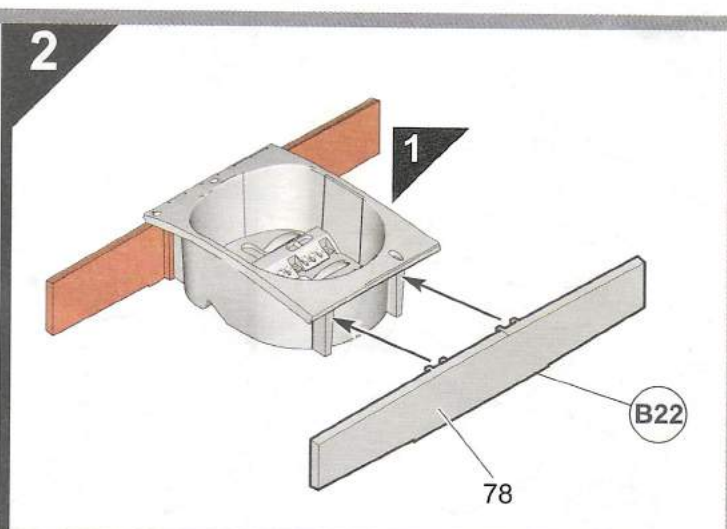
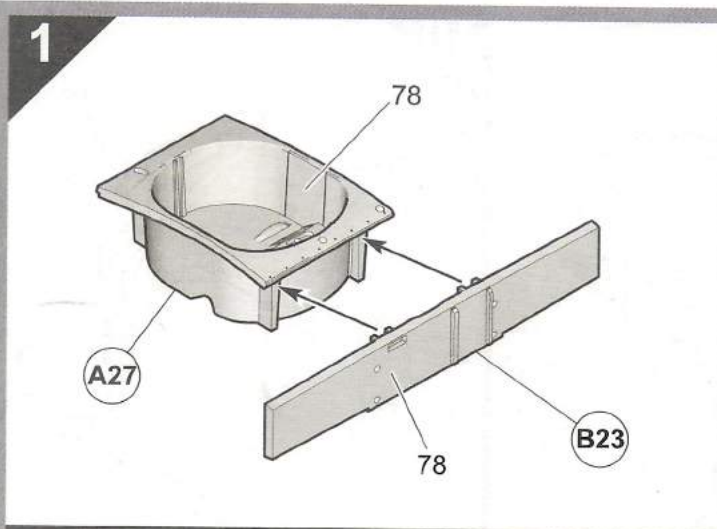

Note: When assembling the bomb bay doors closed, cut parts B7 & B8 as show in this diagram before assembling together, then refer to step 99 on page 17.

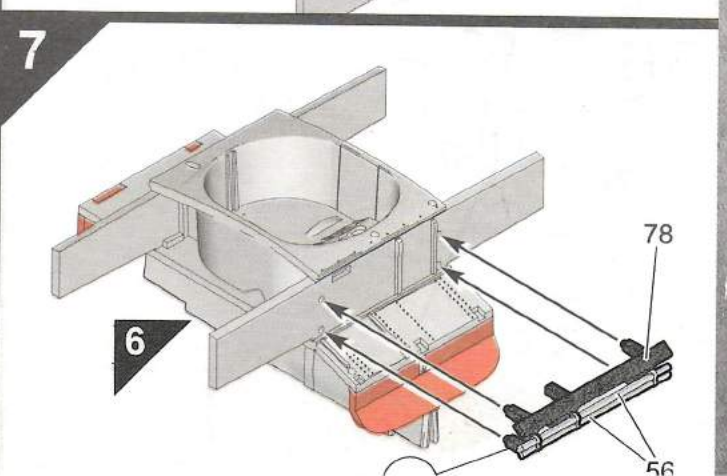
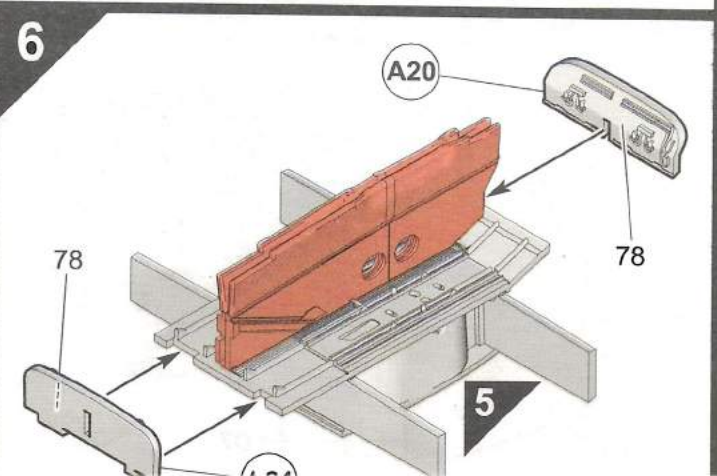
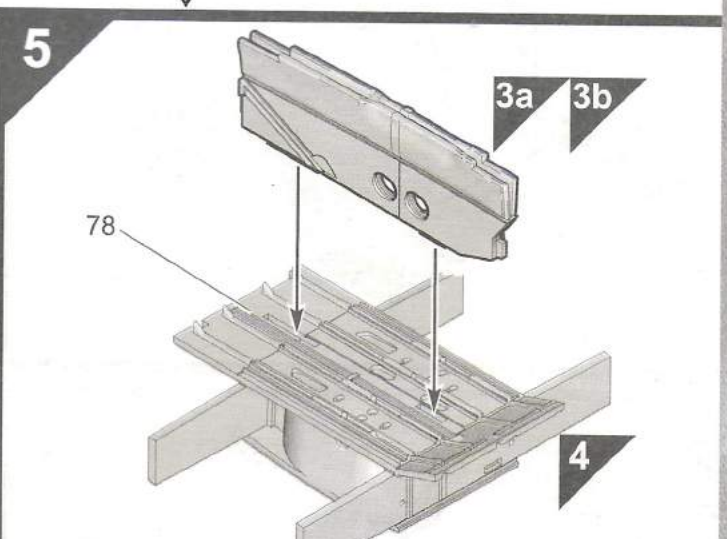
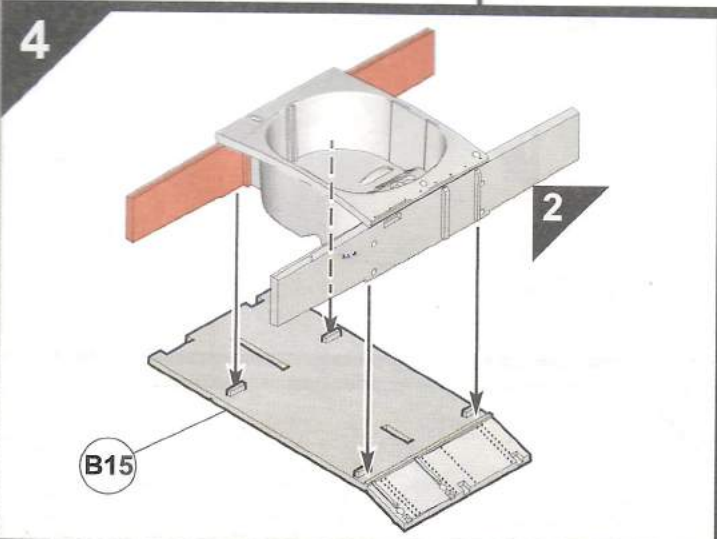
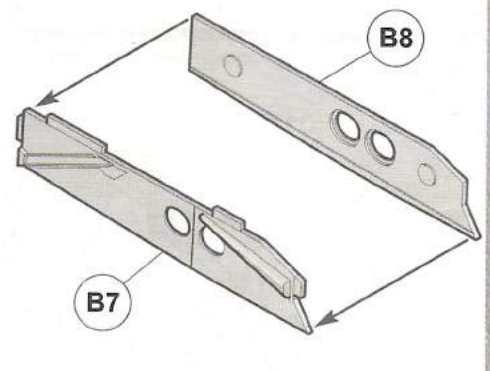

8

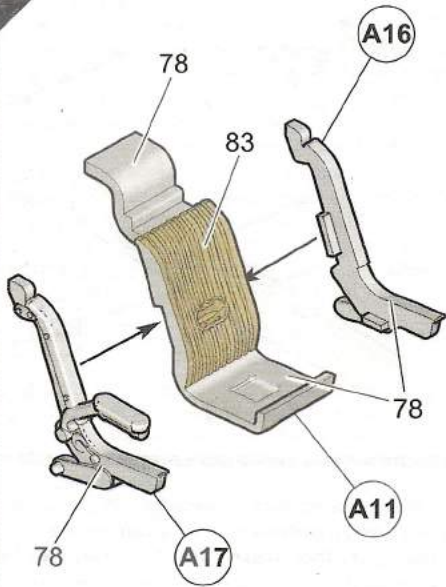

9

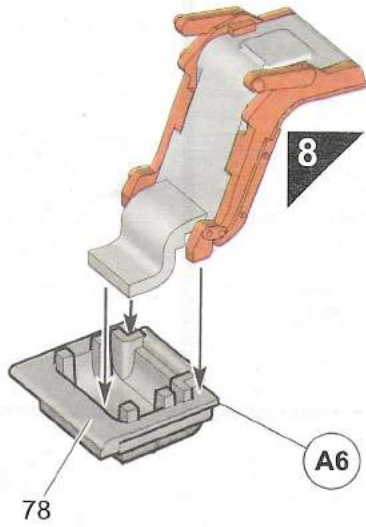

10

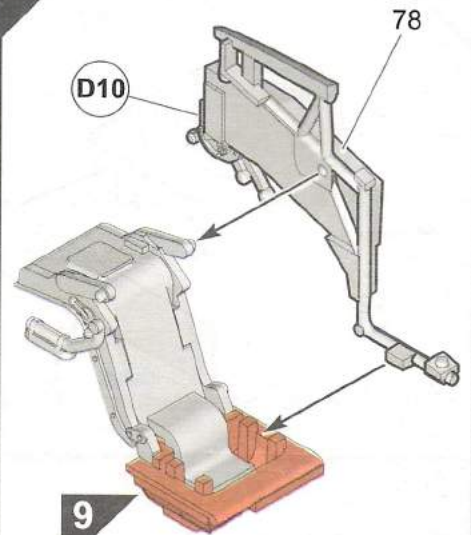

11

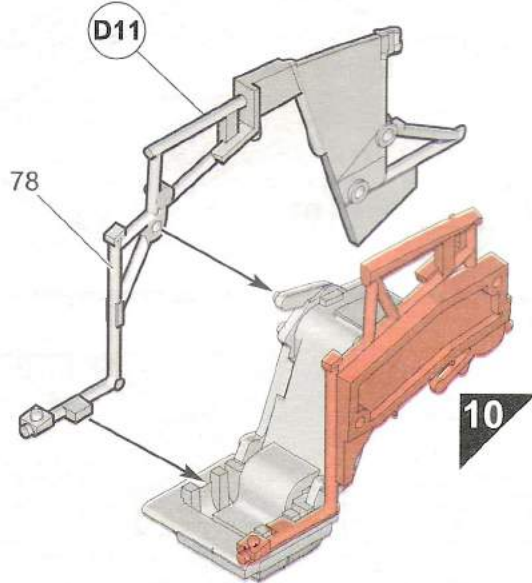

12

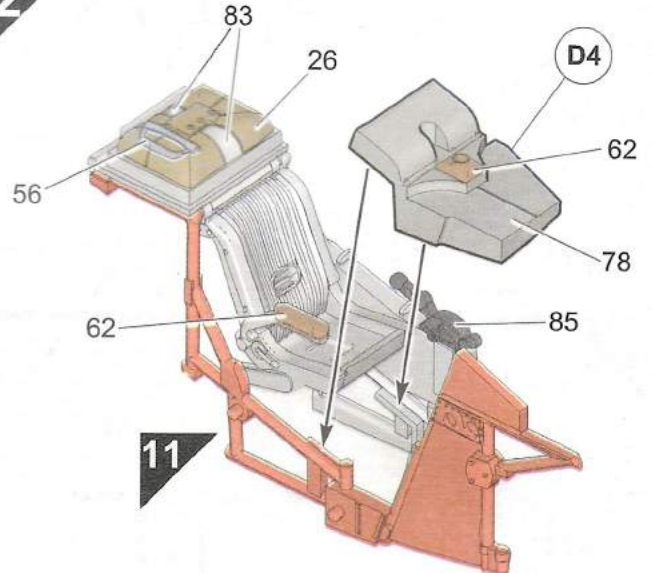

13

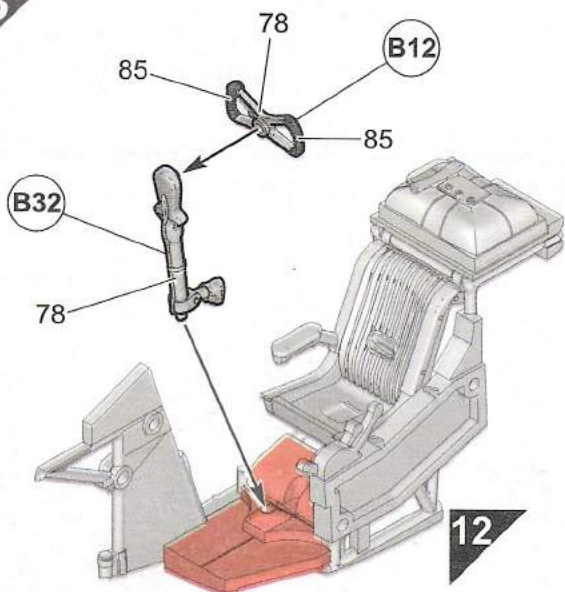

14

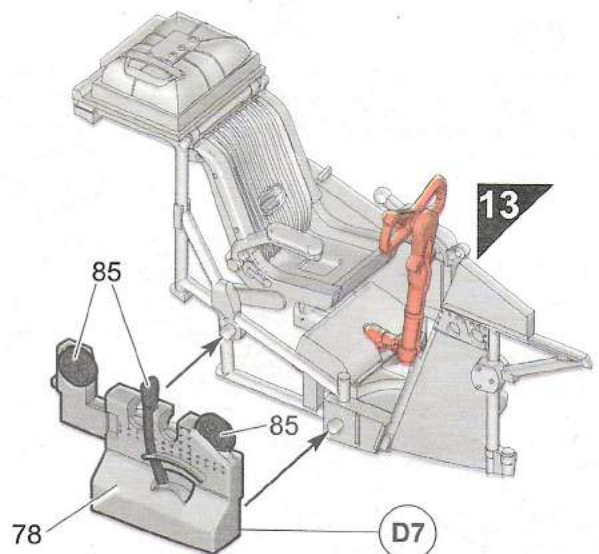

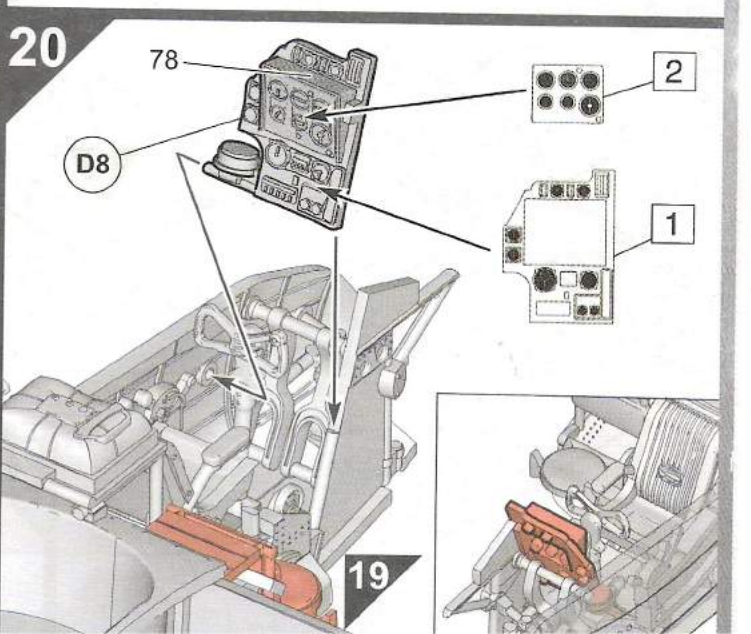
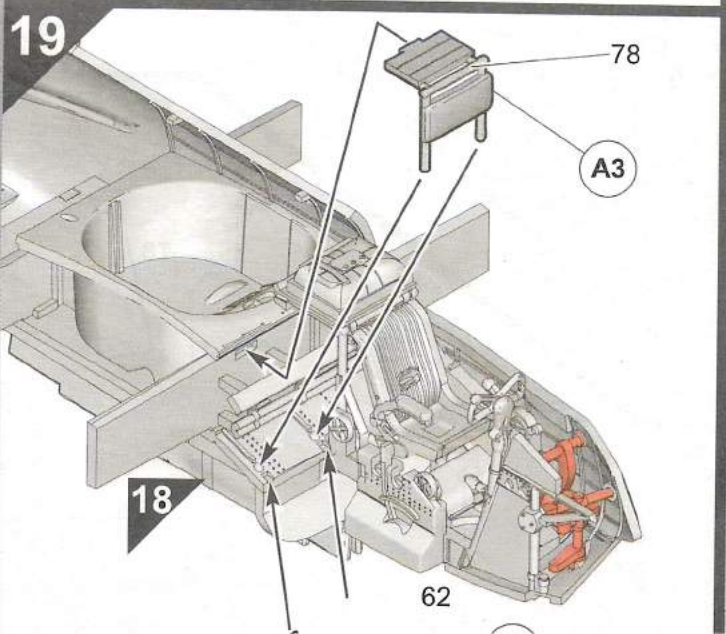
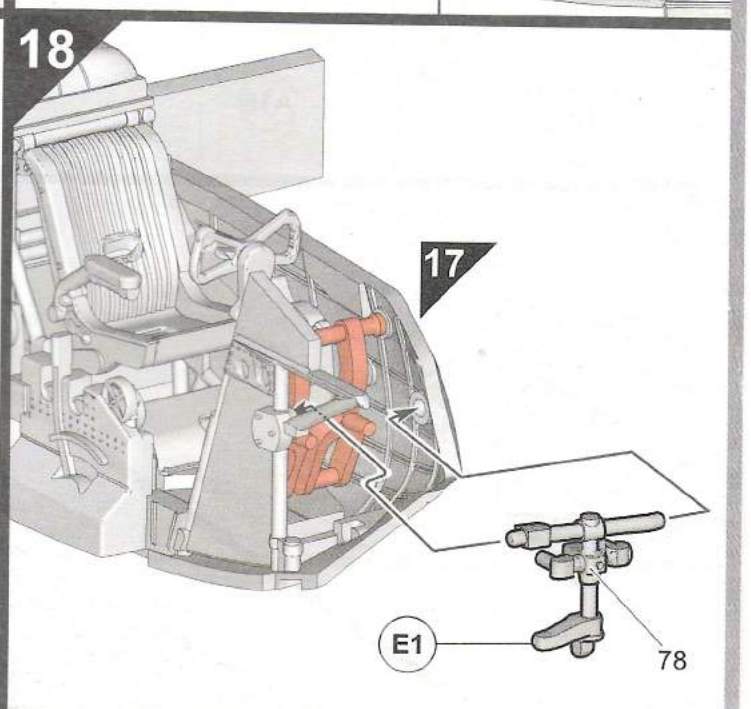
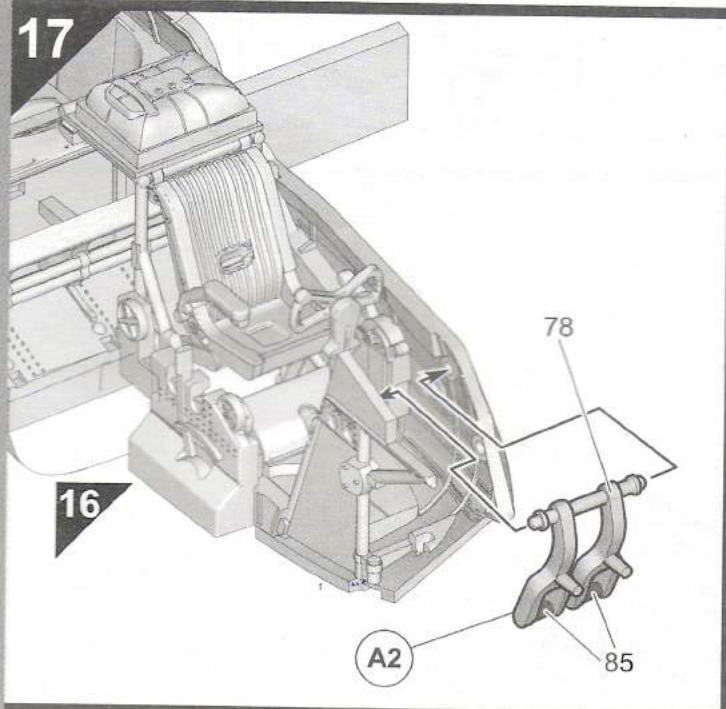
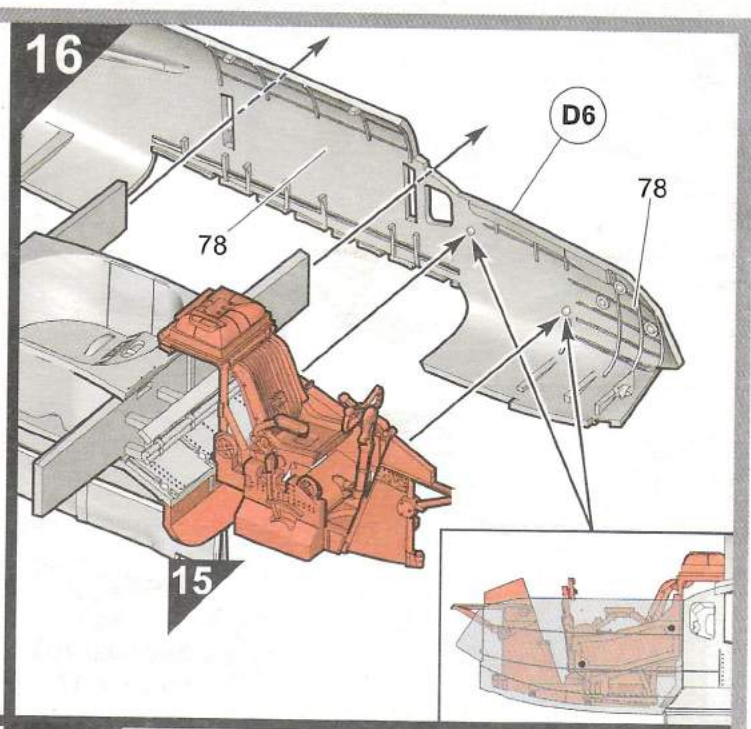
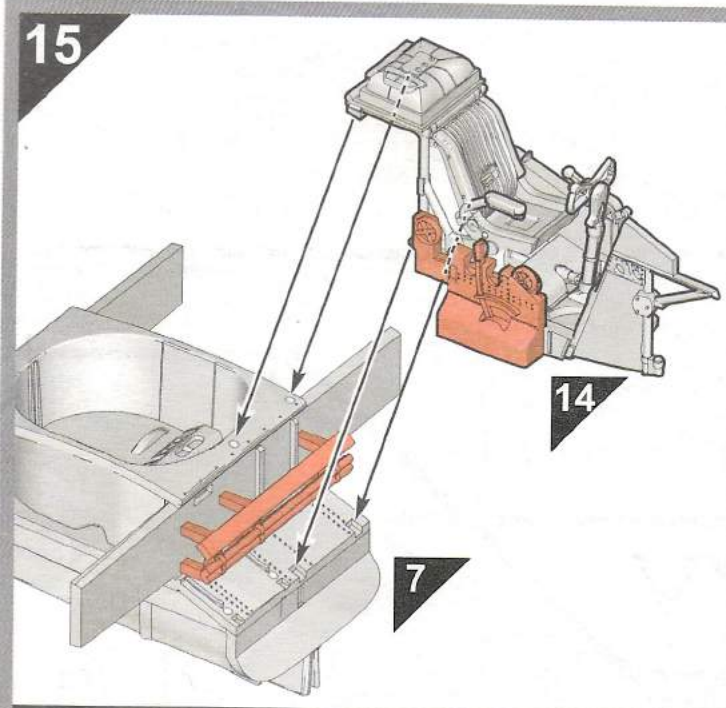

21

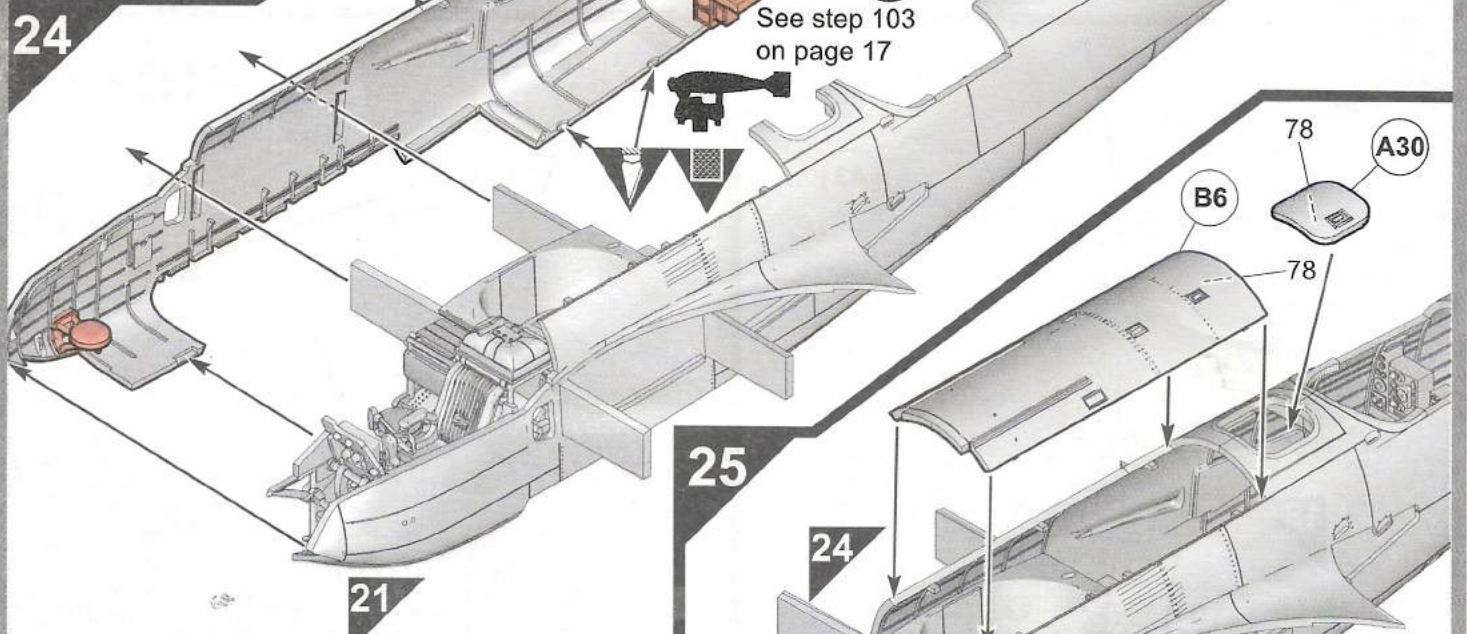
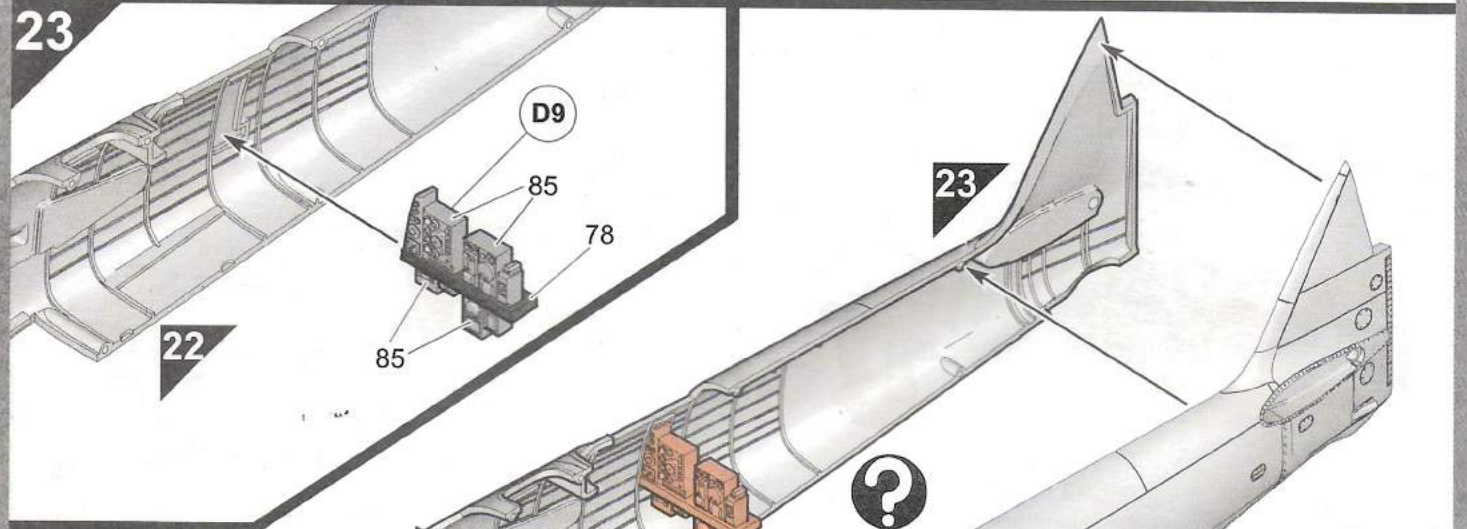
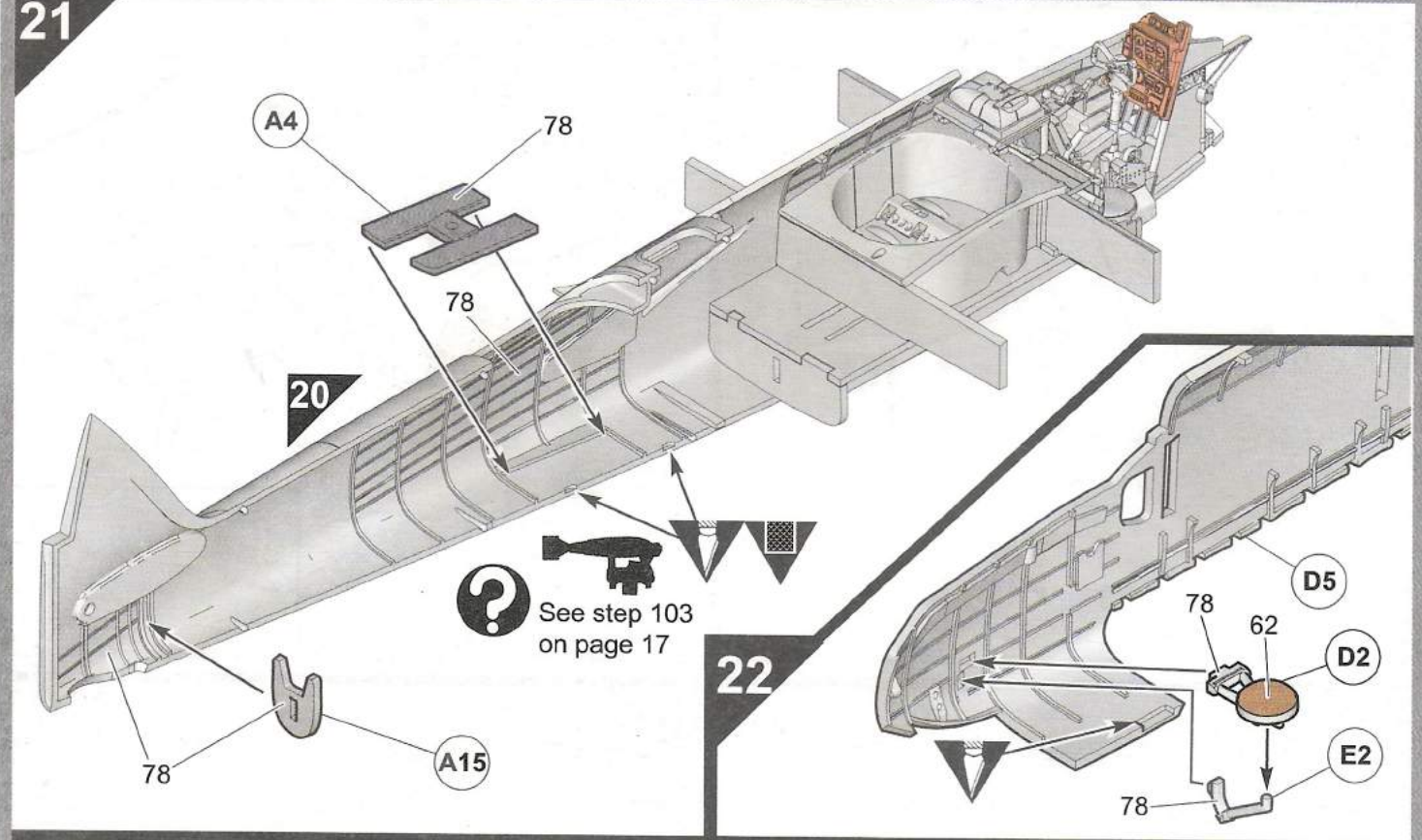

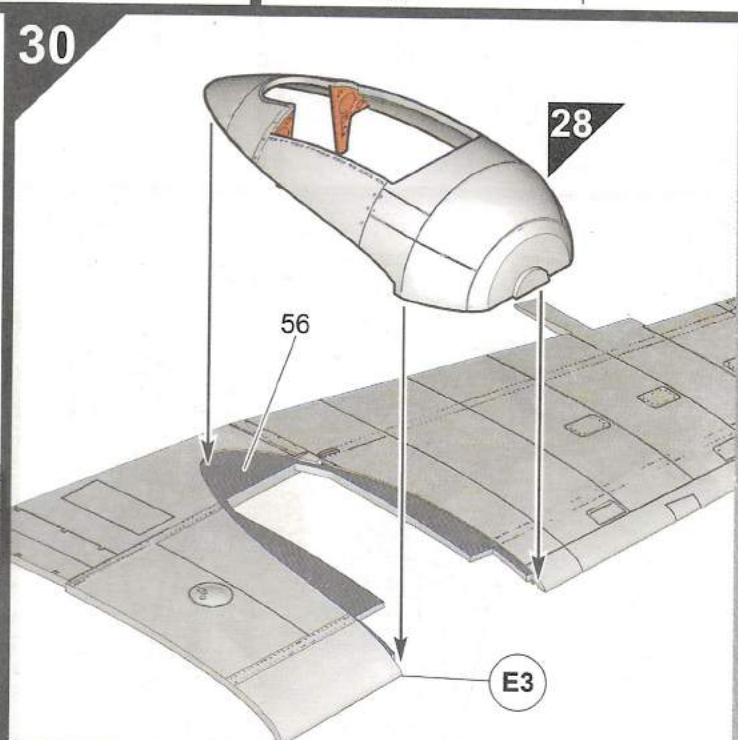
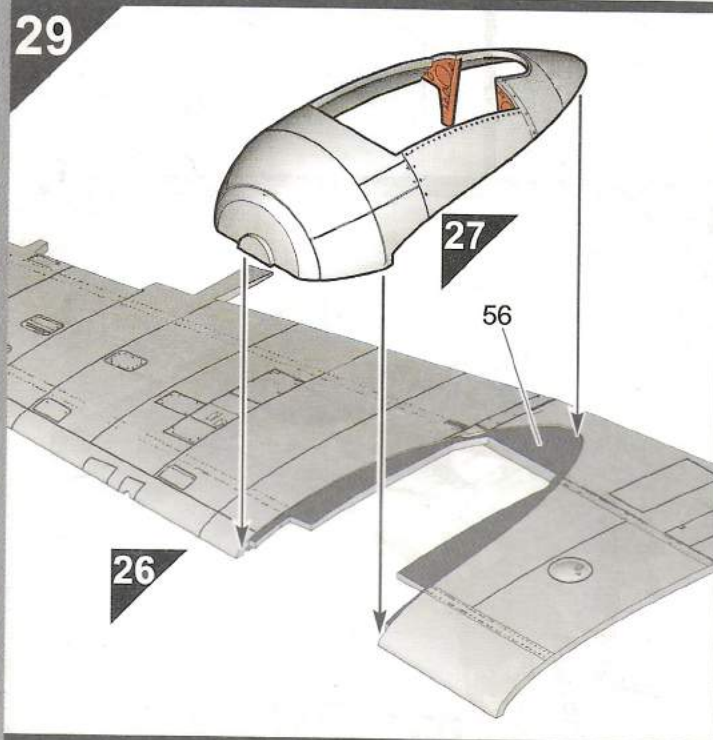
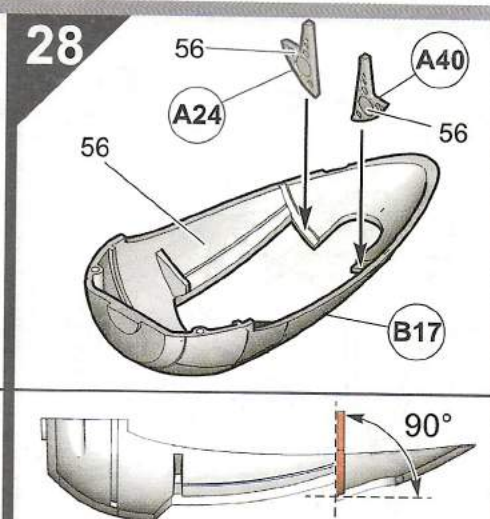
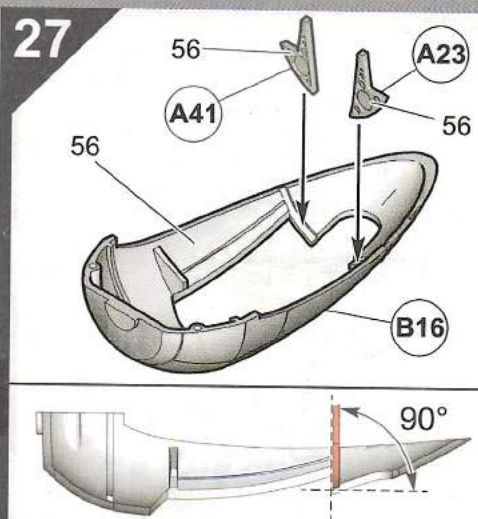
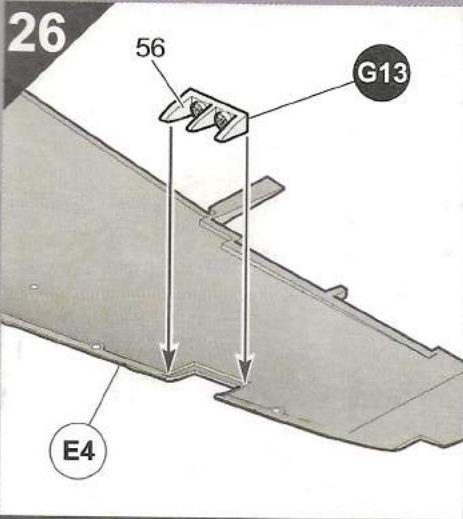

? **Note:** If building the model with the undercarriage up, follow steps 31 and 32 below and miss out steps 33 to 50 on pages 8, 9 and 10.

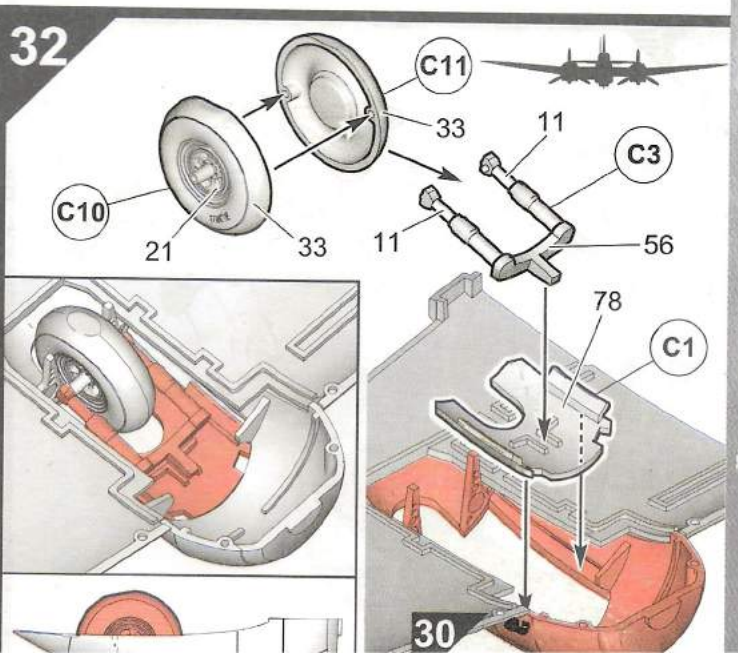
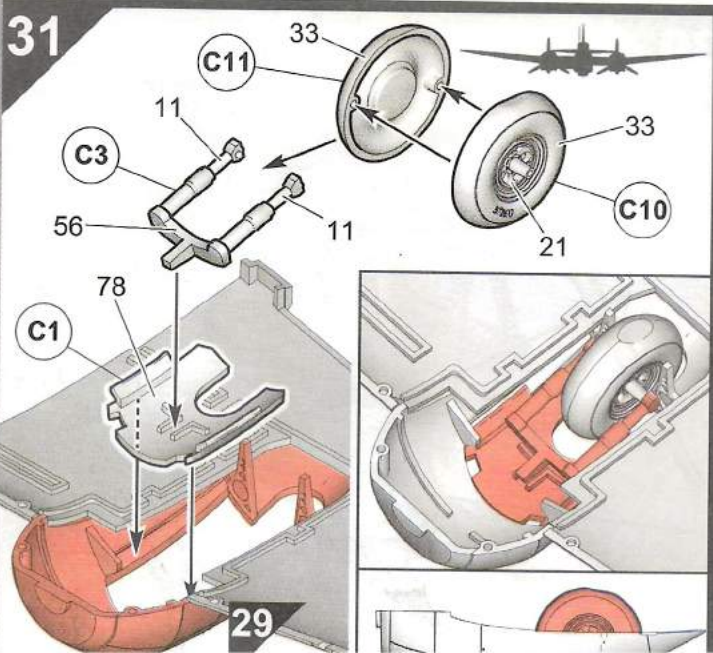

33

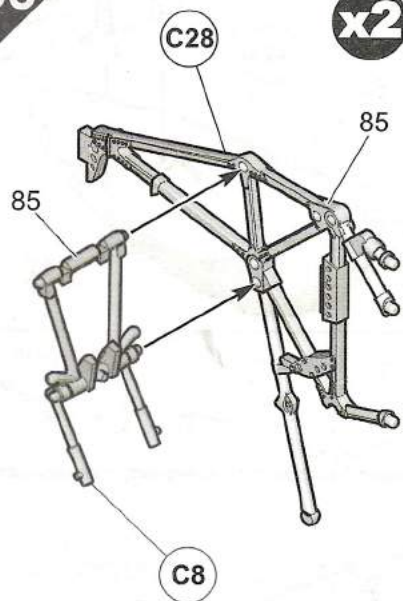

34

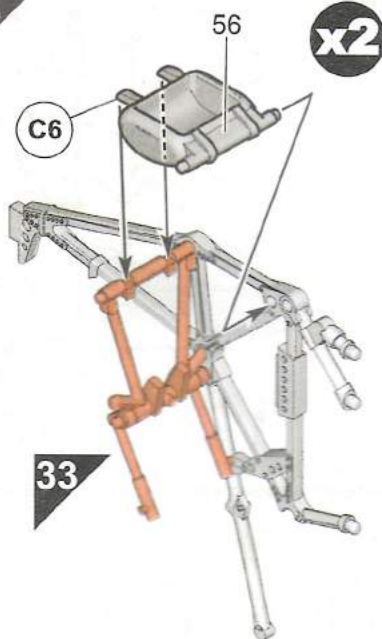

35

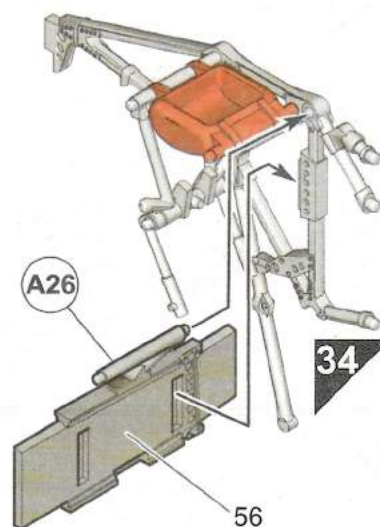

36

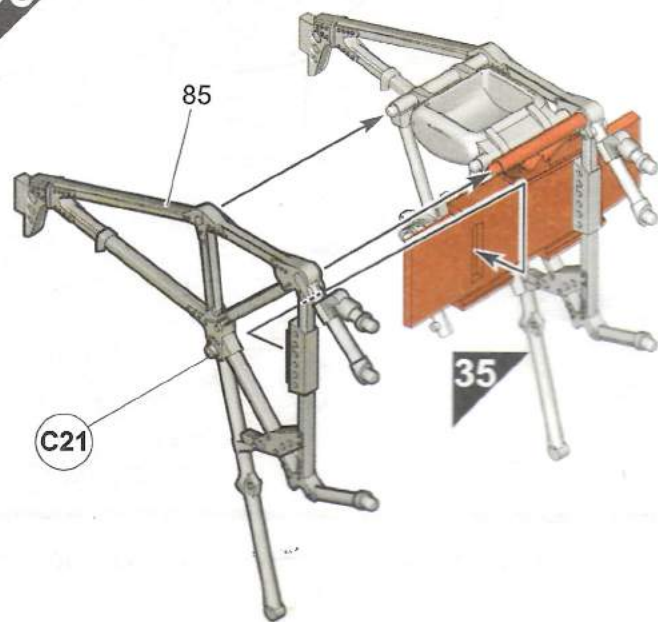

37

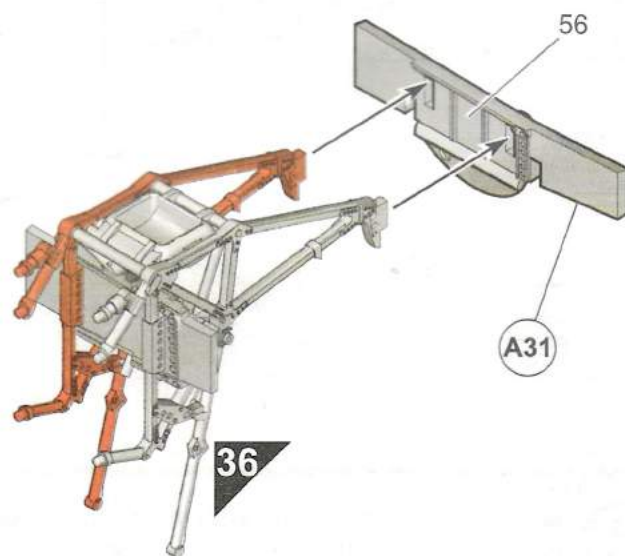

38

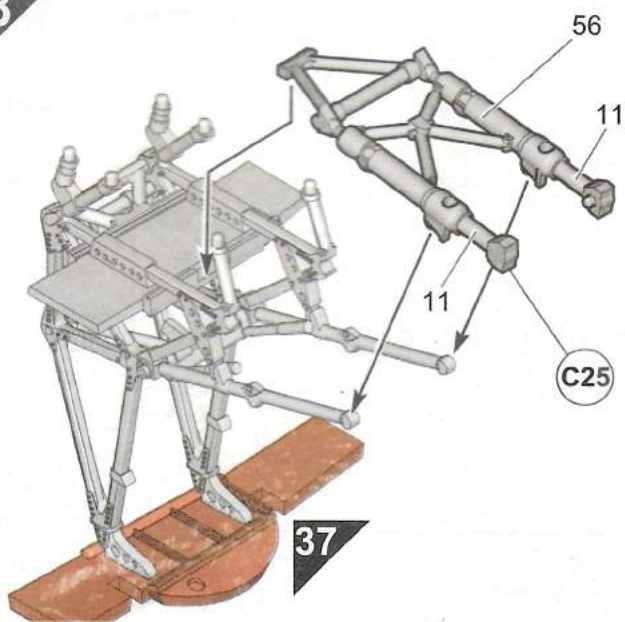

39

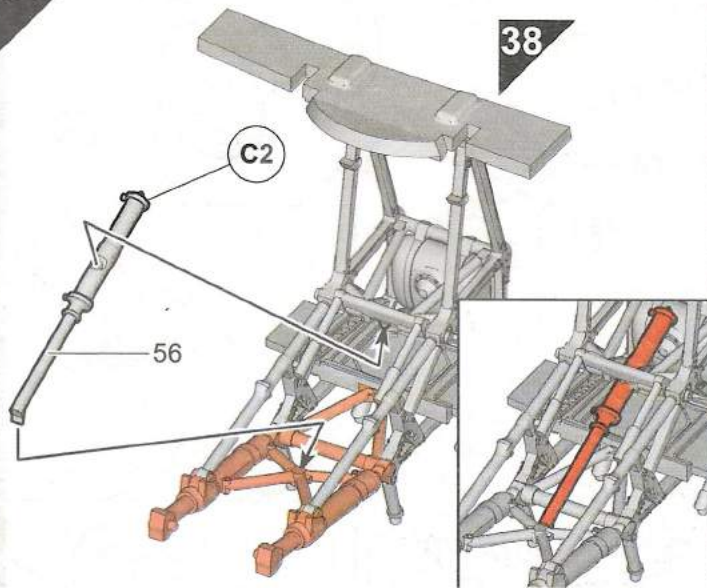

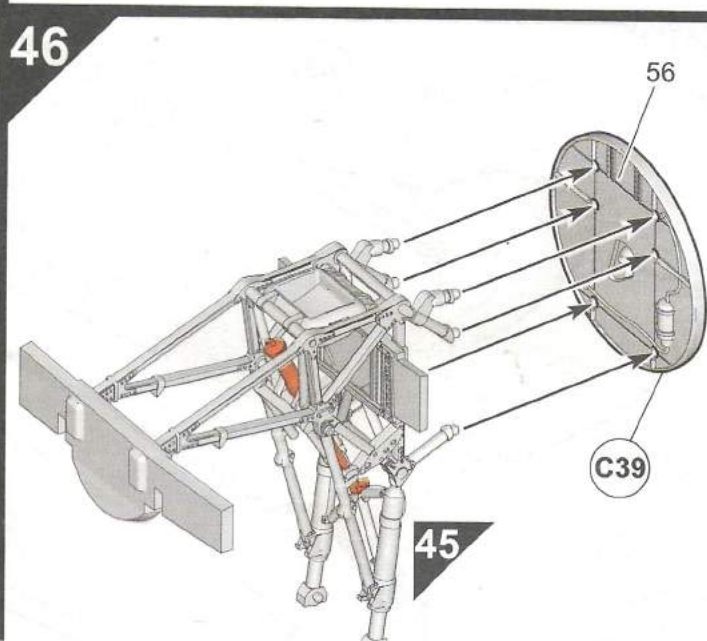
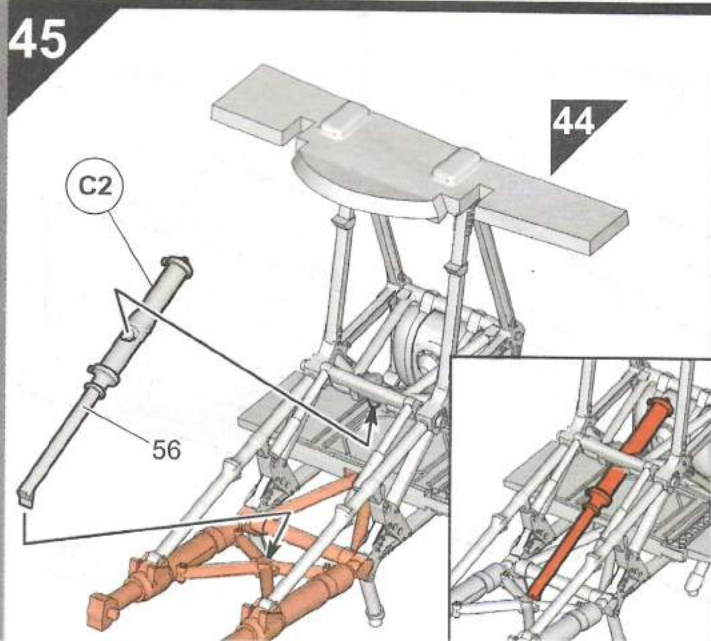
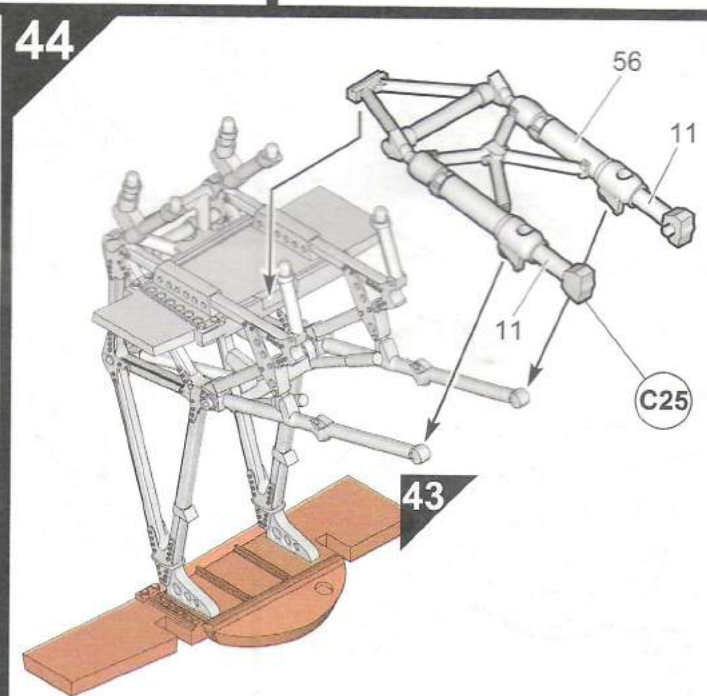
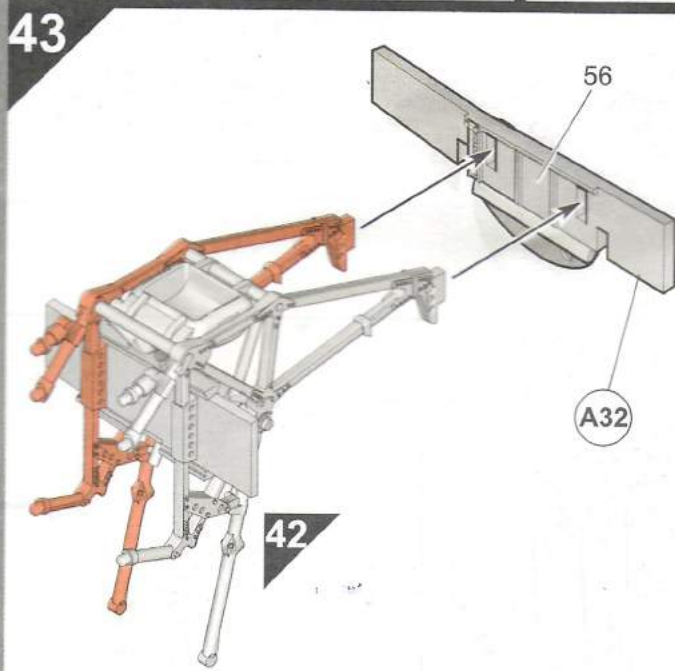
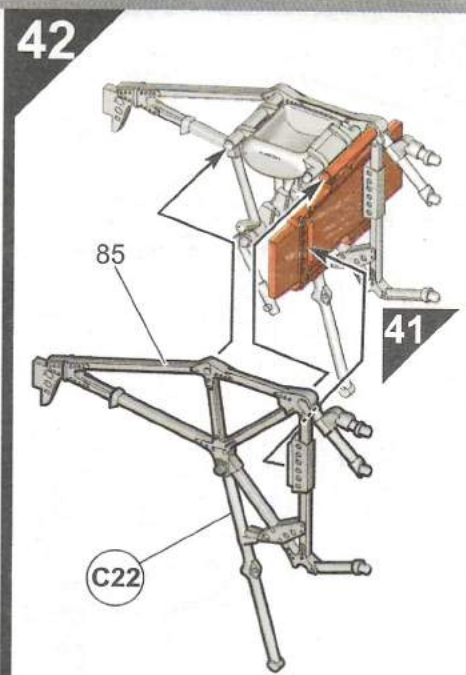
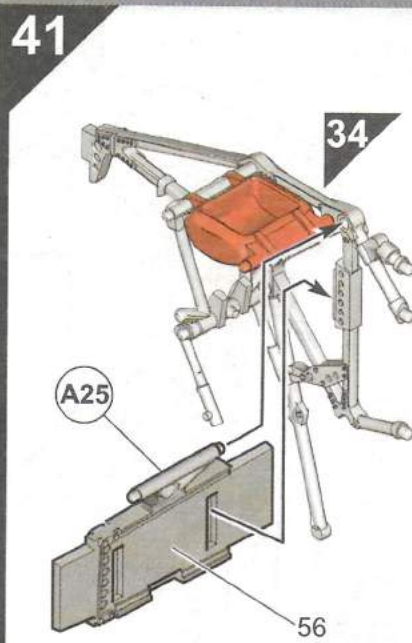
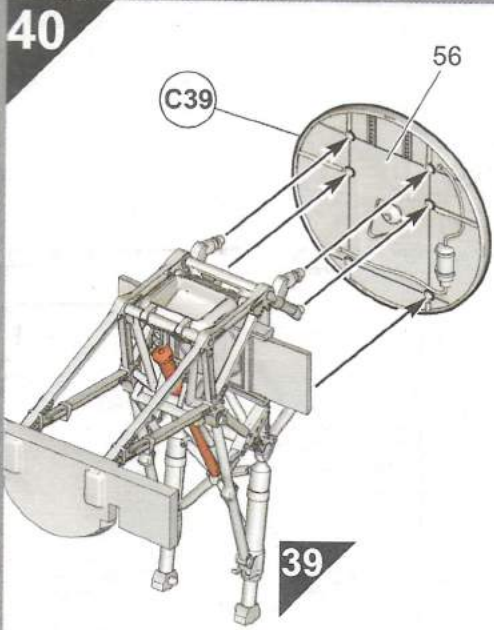

47

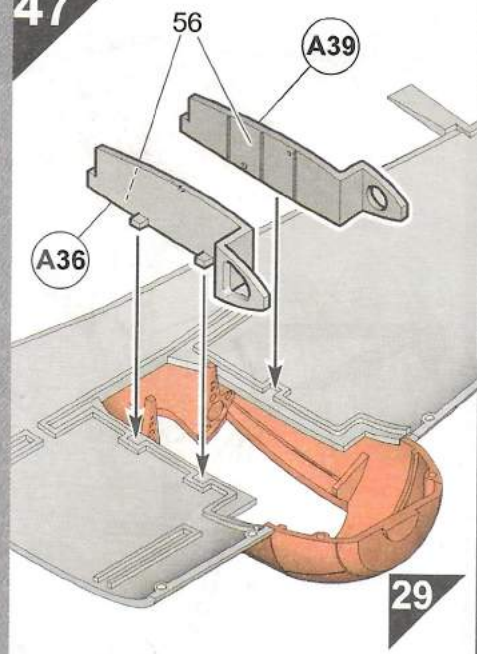

48

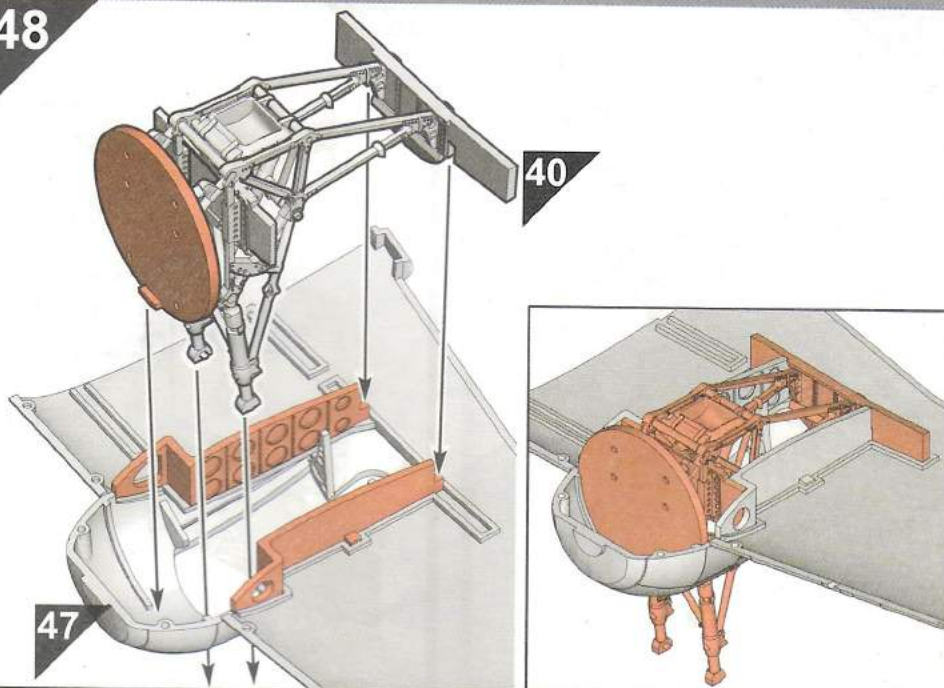

49

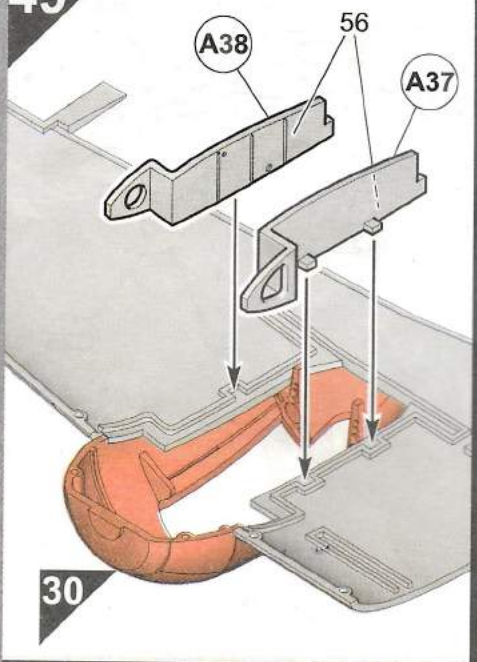

50

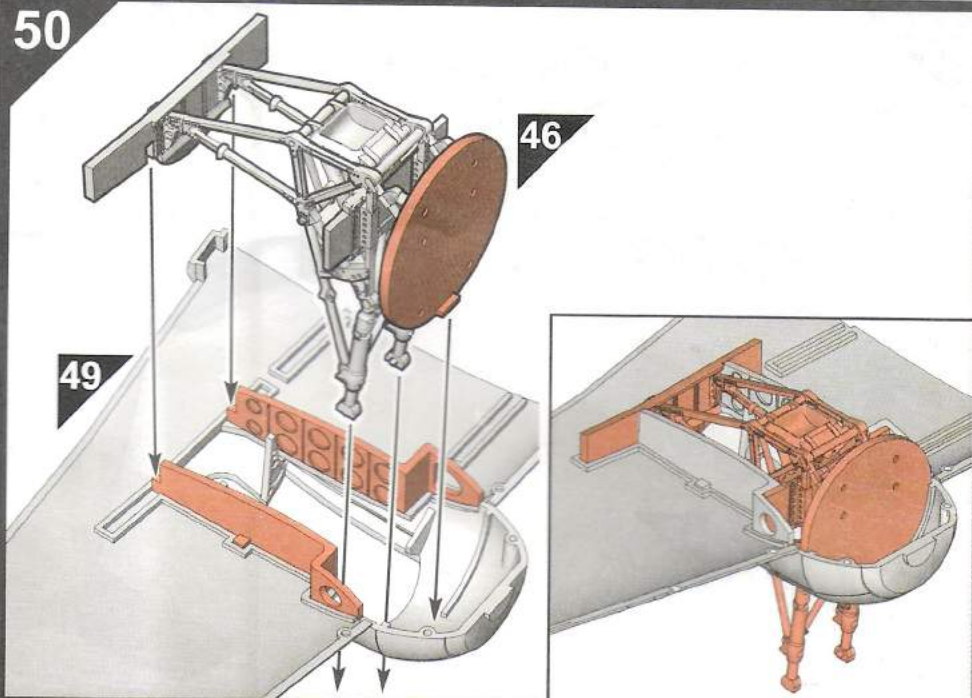

51

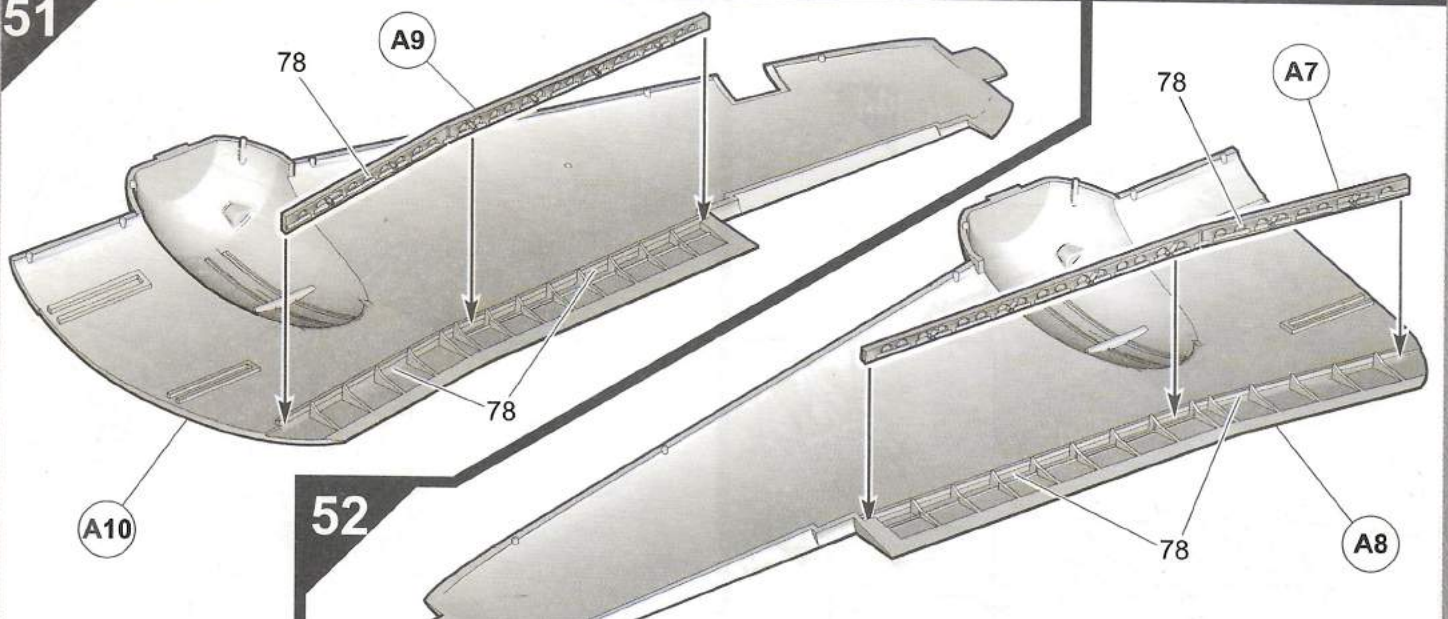

52

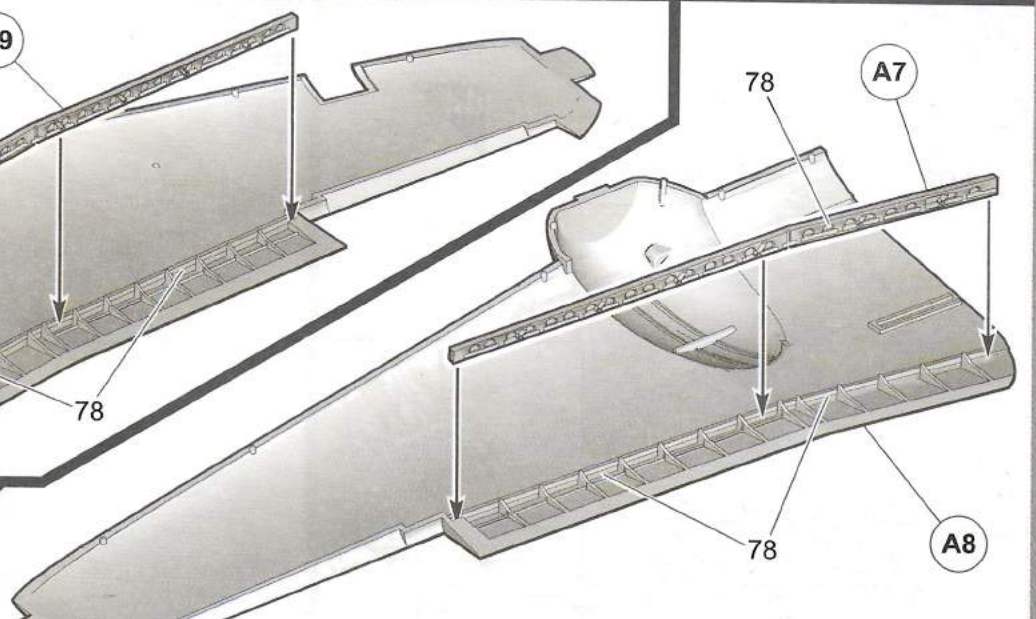

53

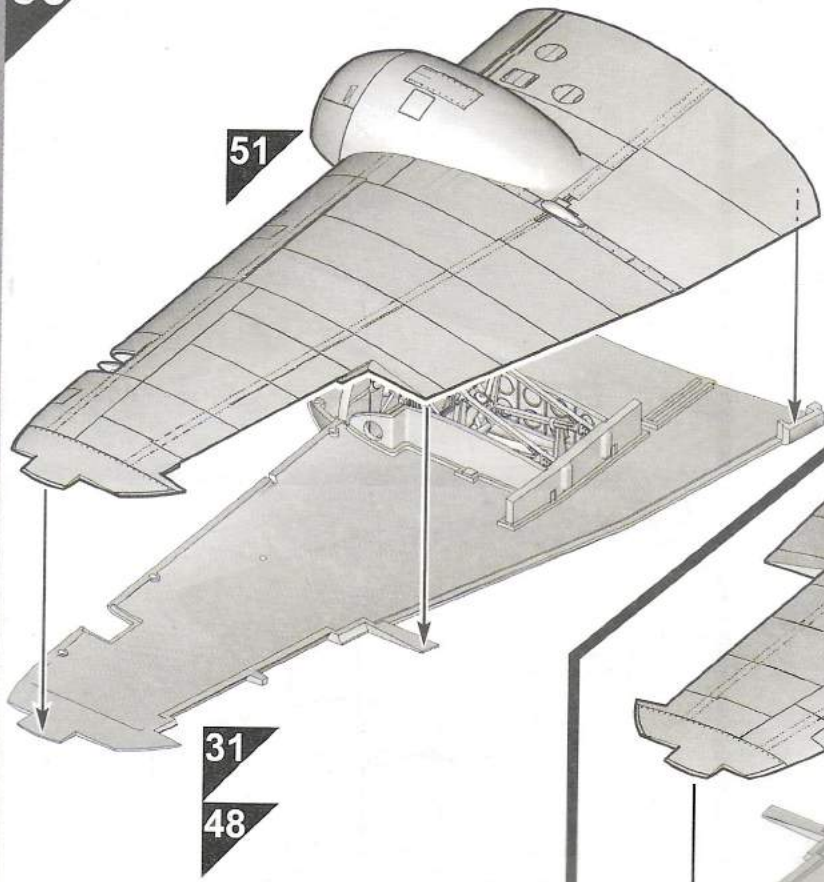

54

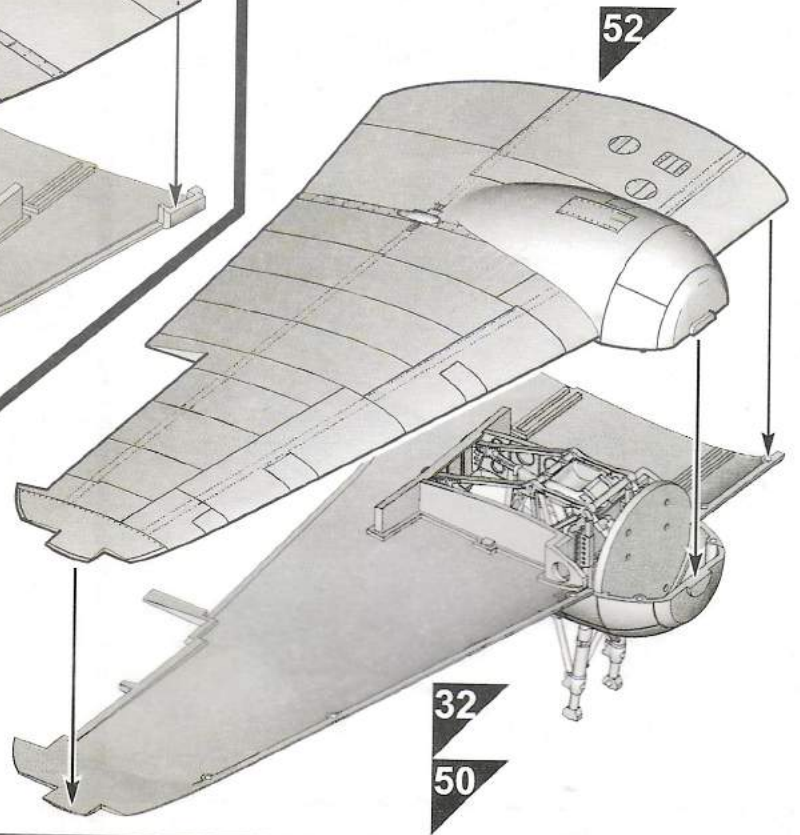

55

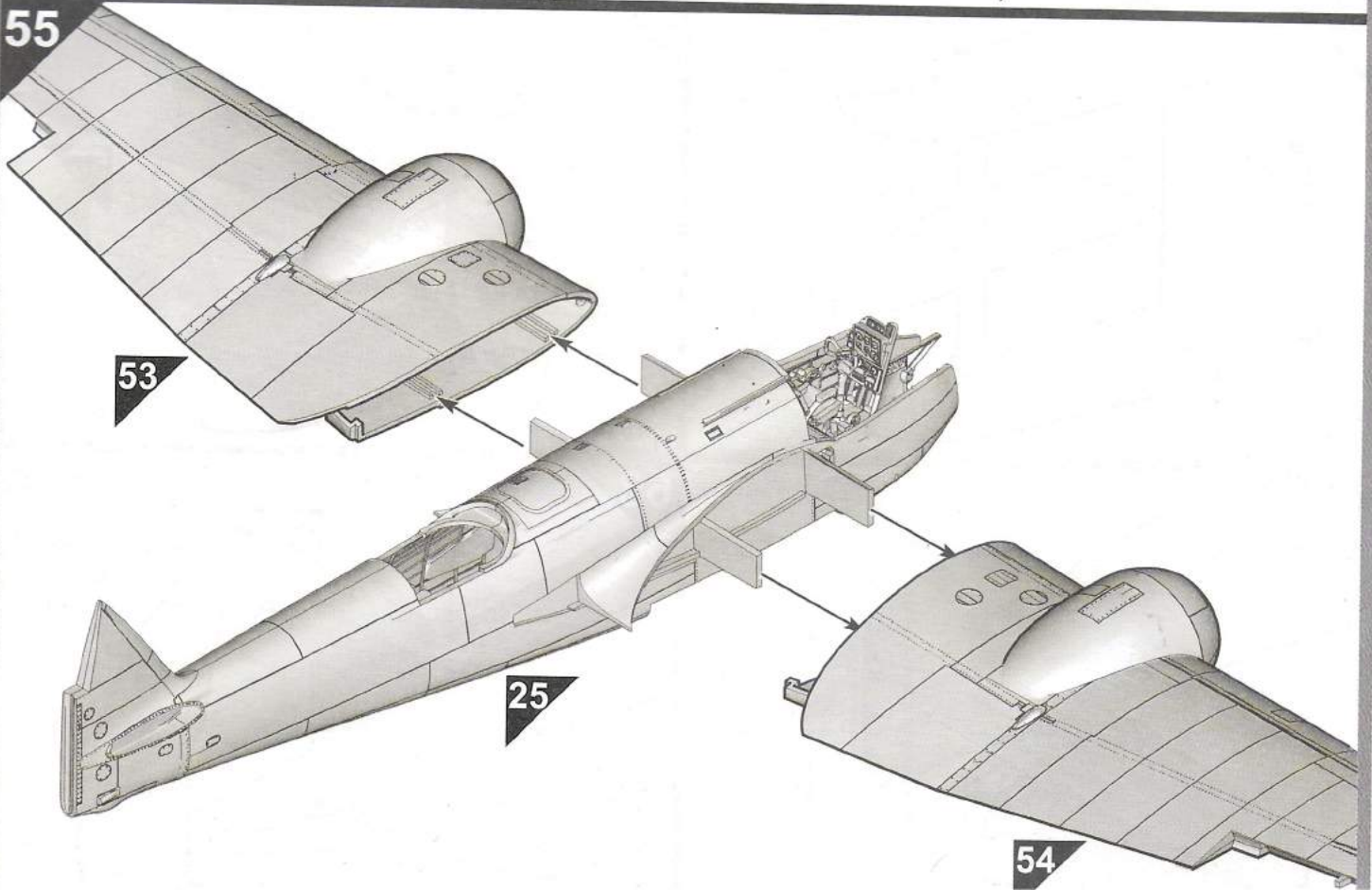

56

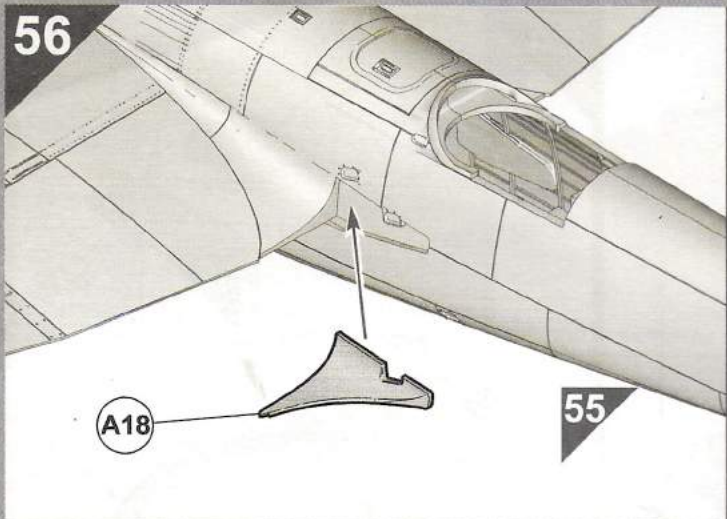

A18

55

57

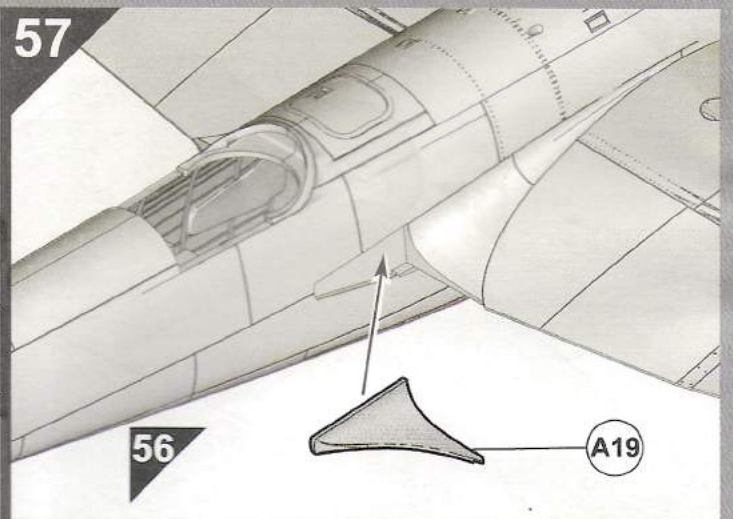

56

A19

58

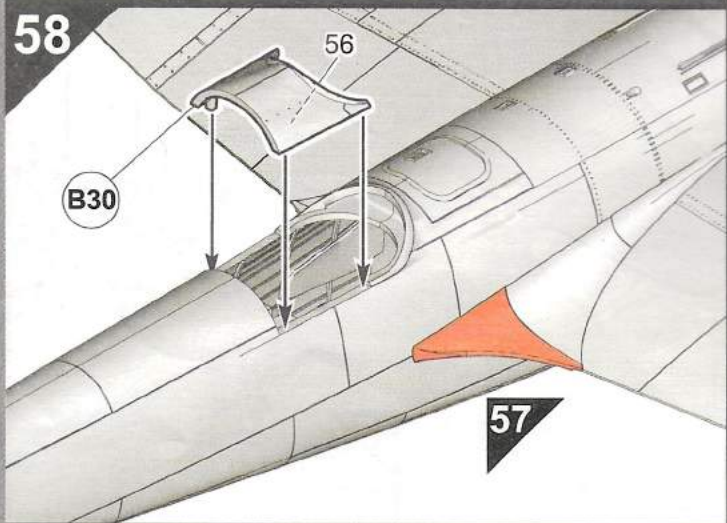

B30

56

57

59

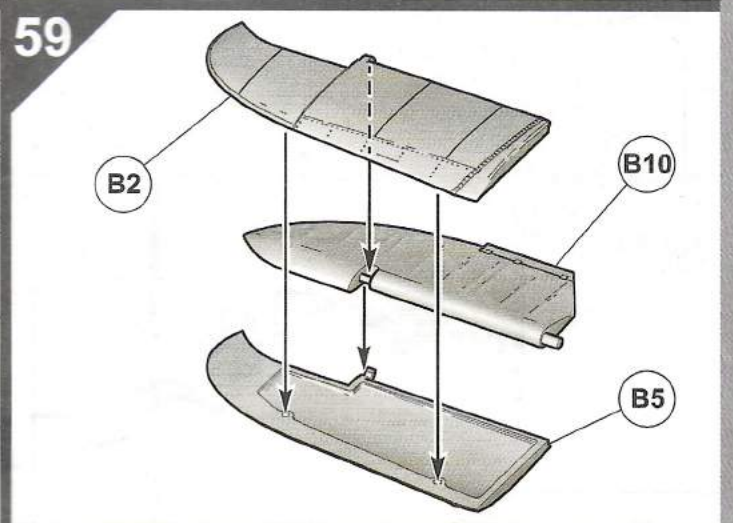

B2

B10

B5

60

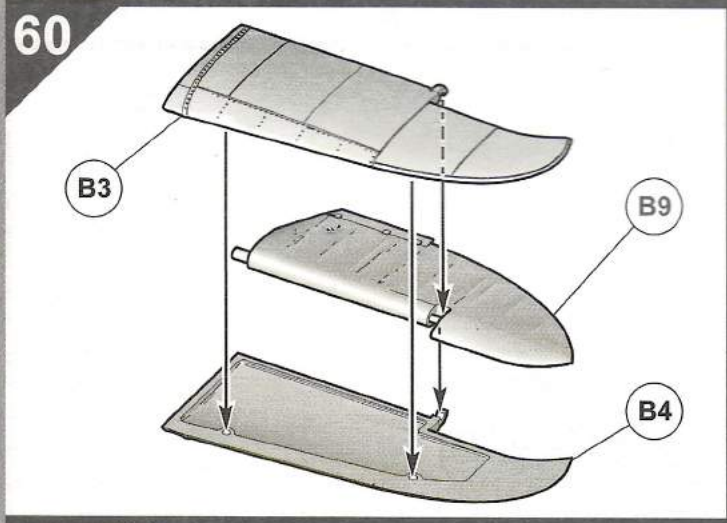

B3

B9

B4

61

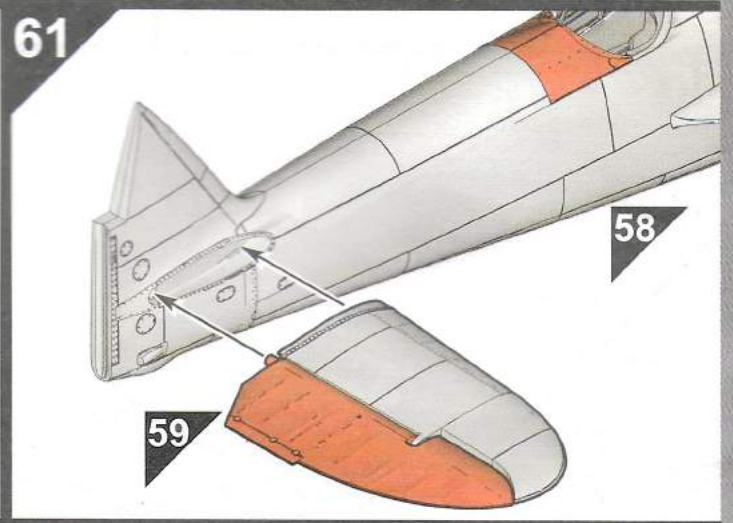

58

59

62

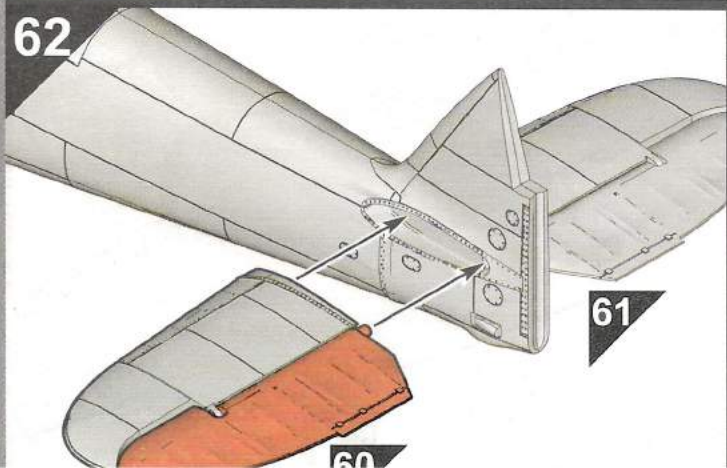

61

60

63

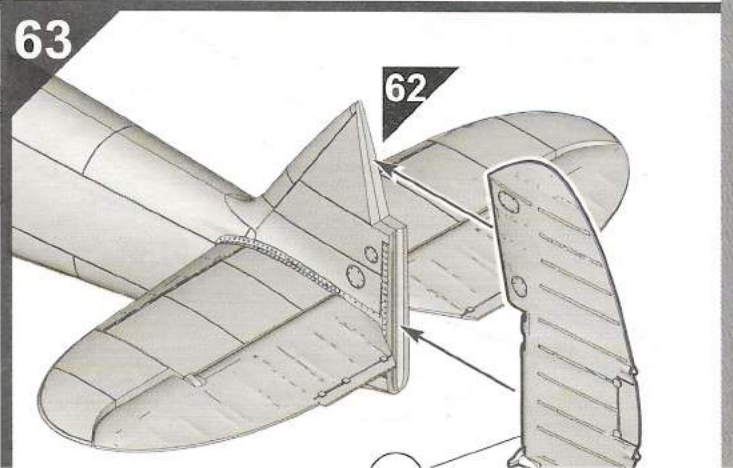

62

64

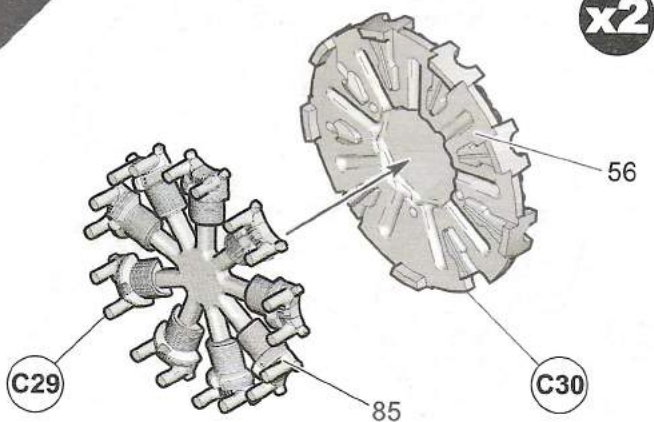

65

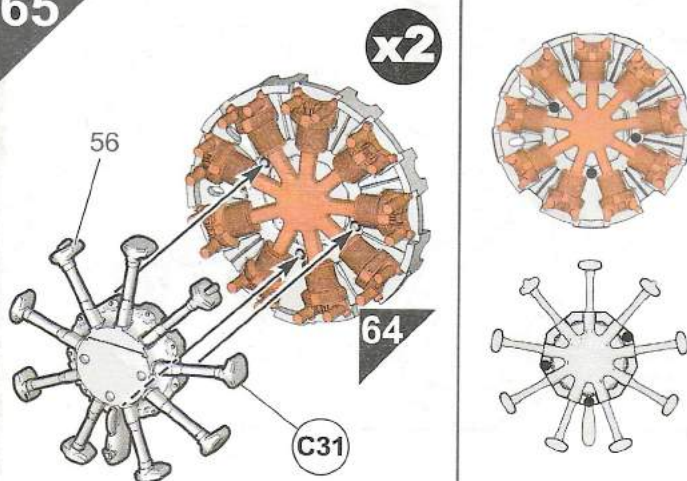

66

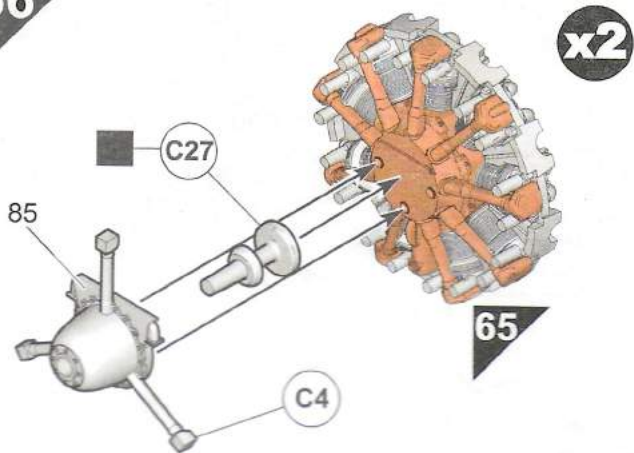

67

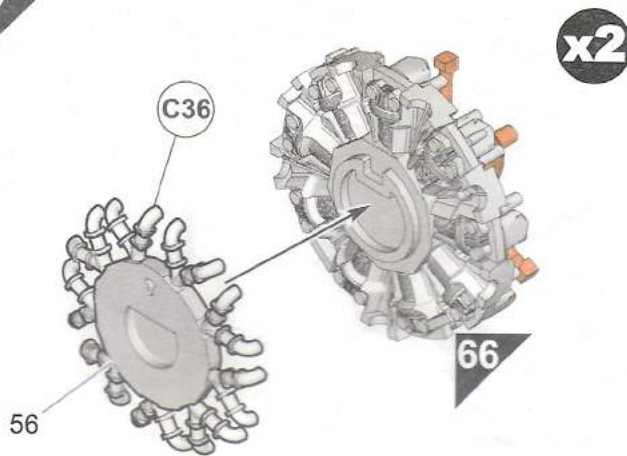

68

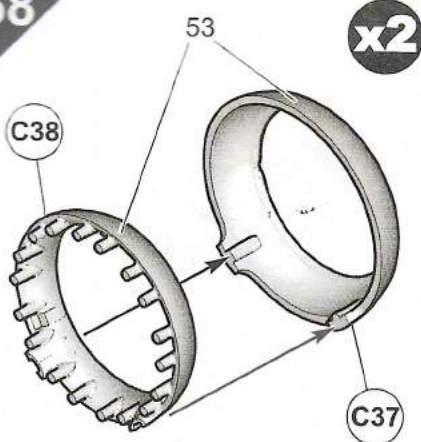

69

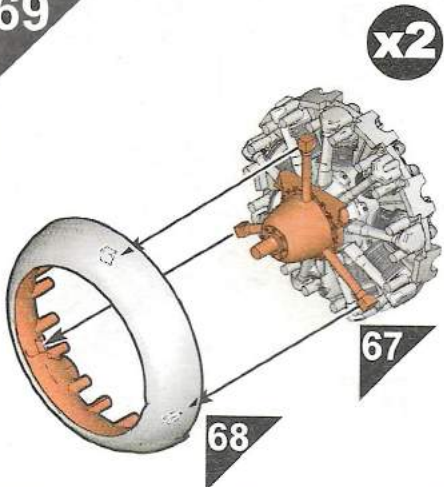

70

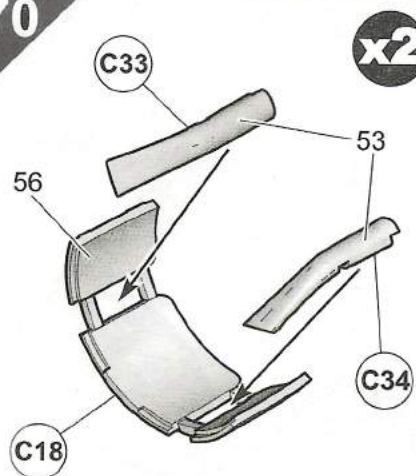

71

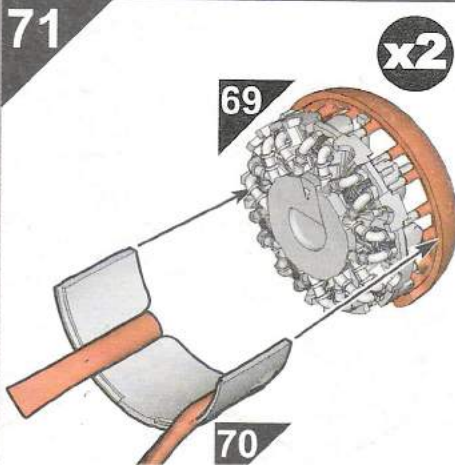

72

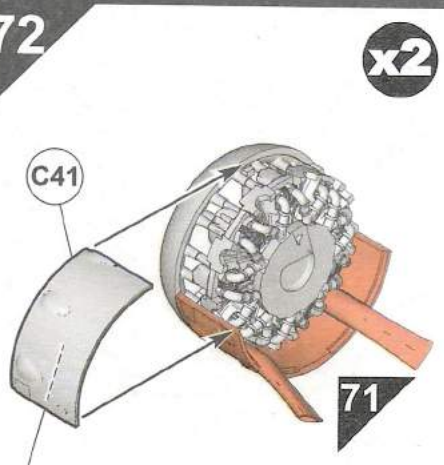

73

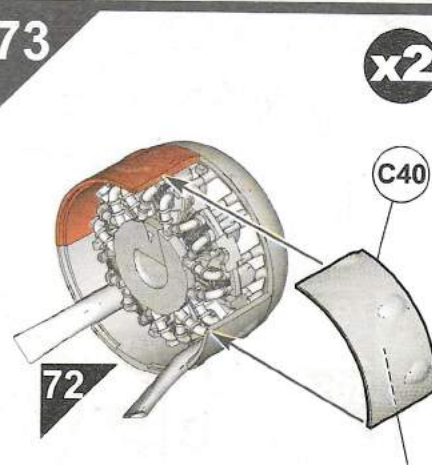

74

x2

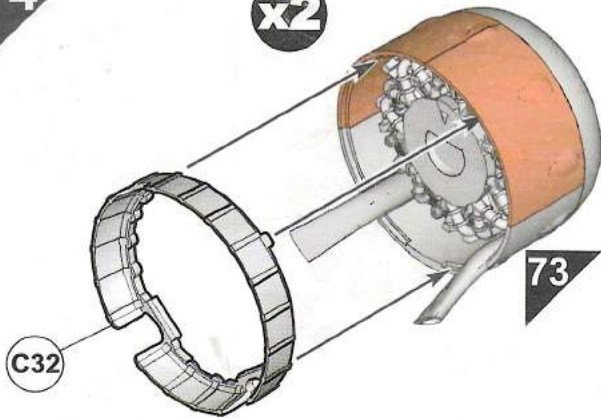

75

x2

?

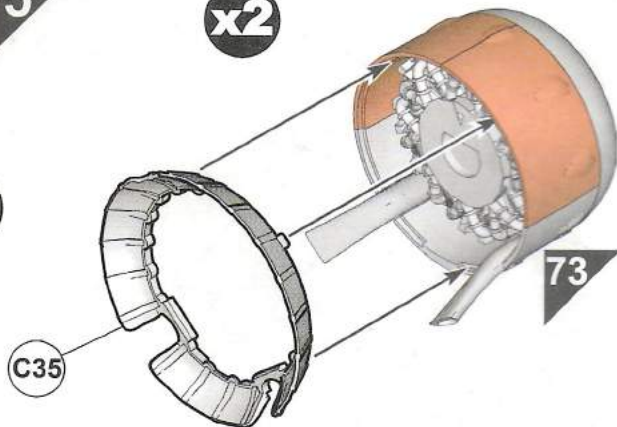

76

x2

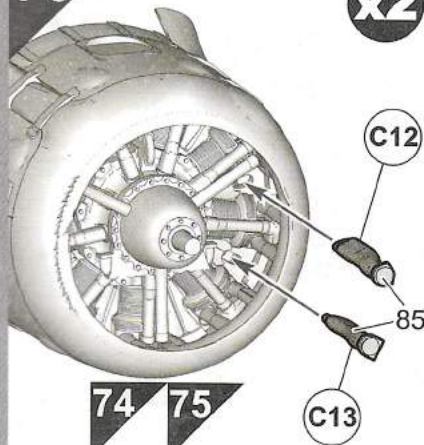

77

A

x2

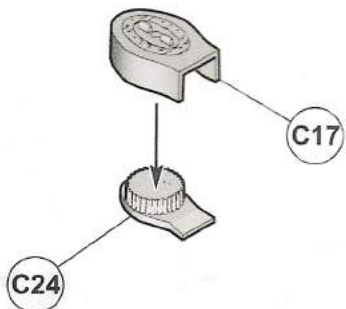

78

B

x2

?

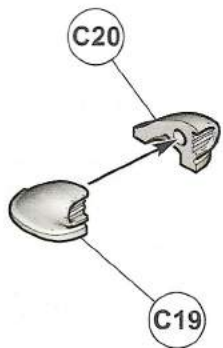

79

A

x2

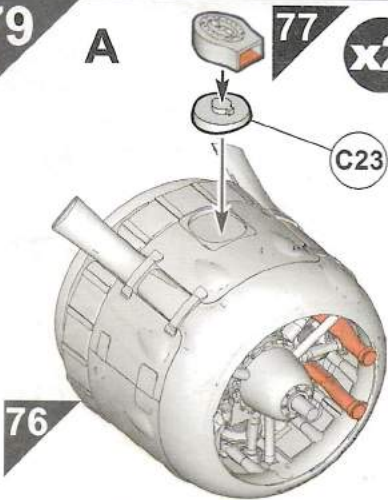

80

B

x2

?

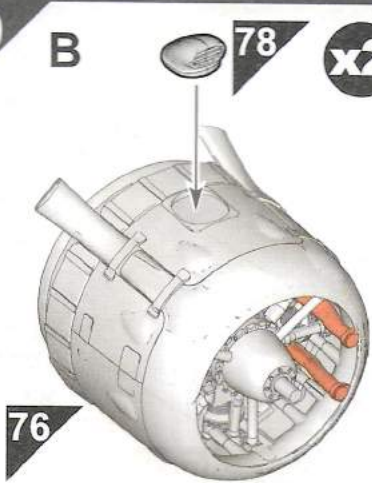

81

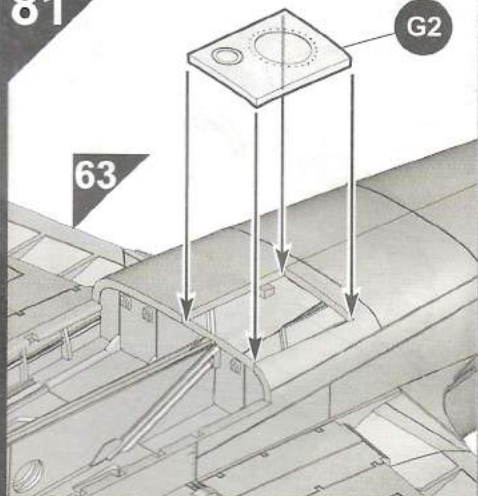

82

A 79
B 80

A 79
B 80

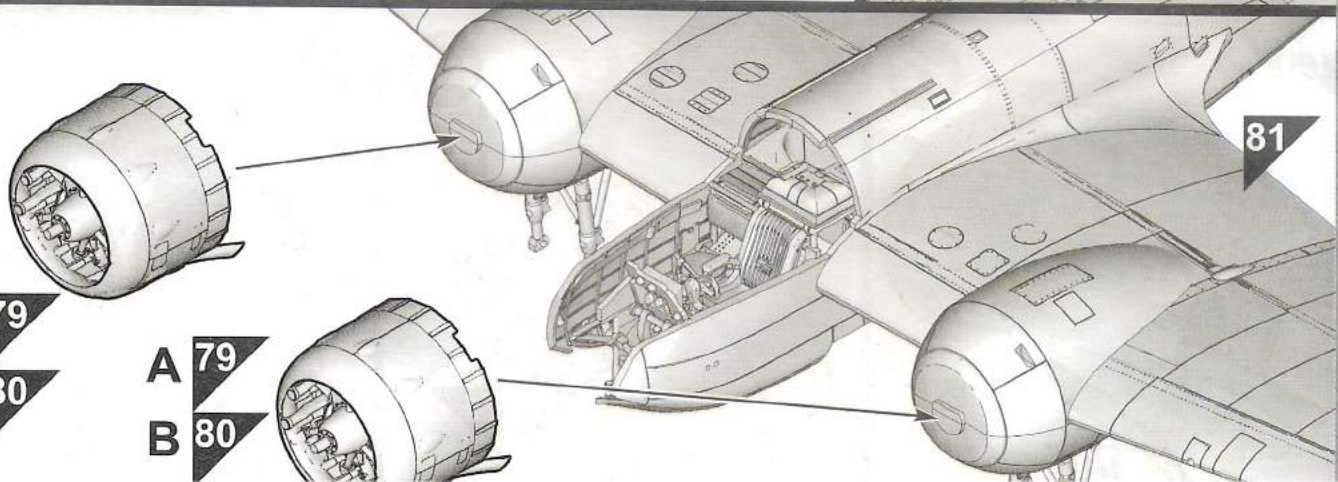

83

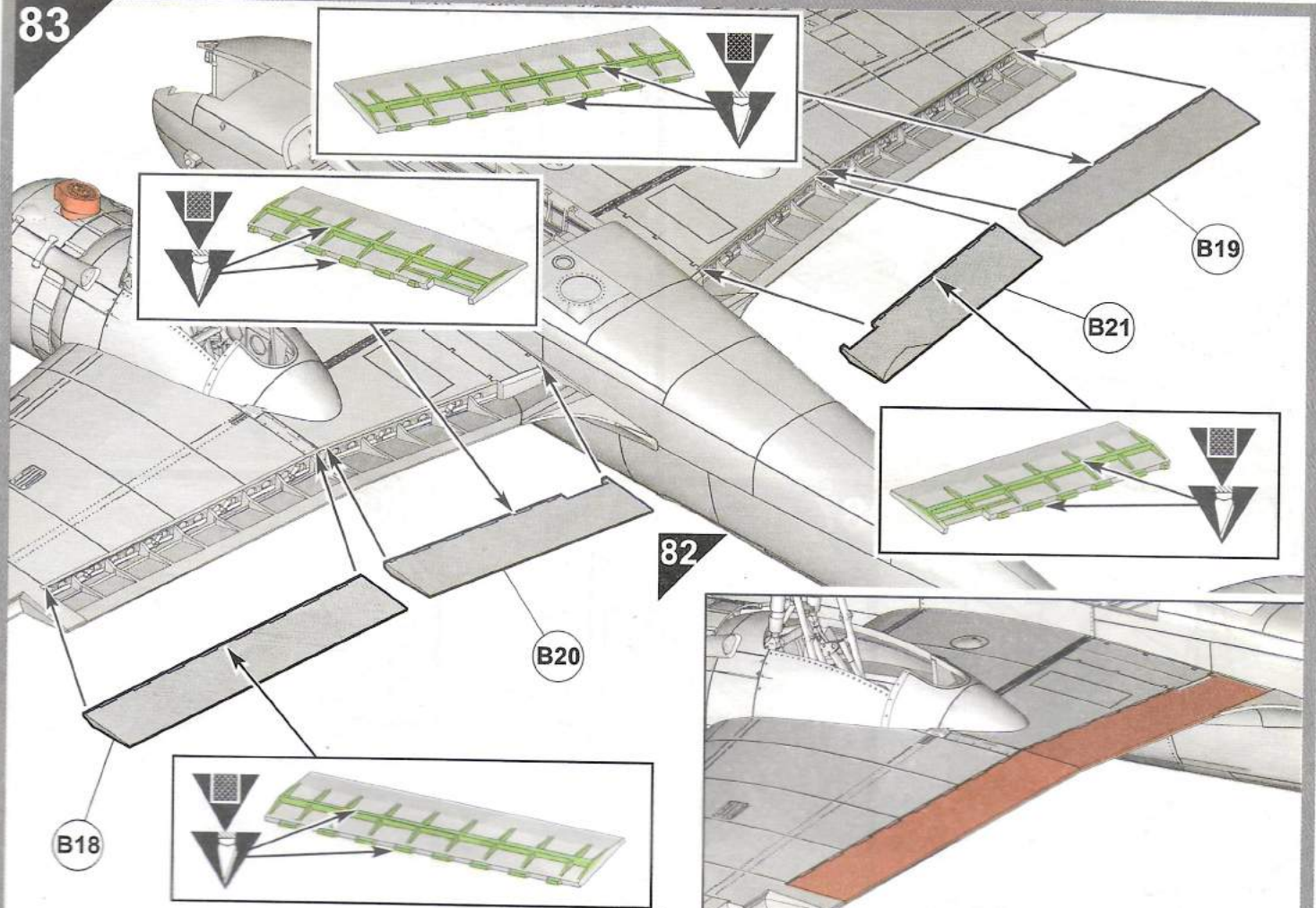

82

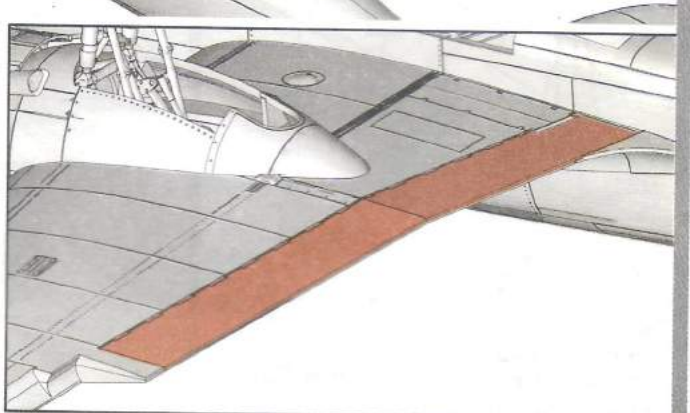

82

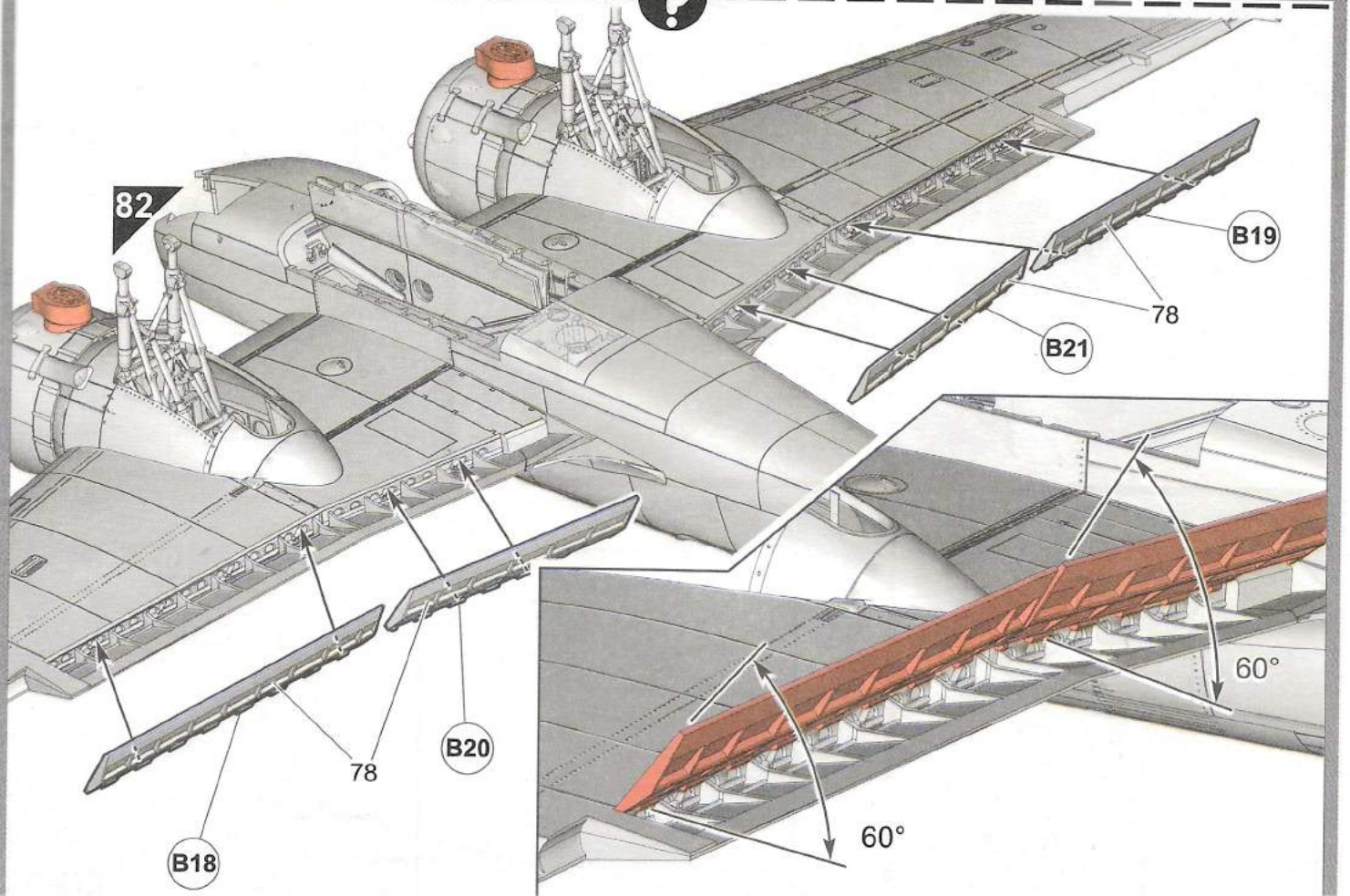

84

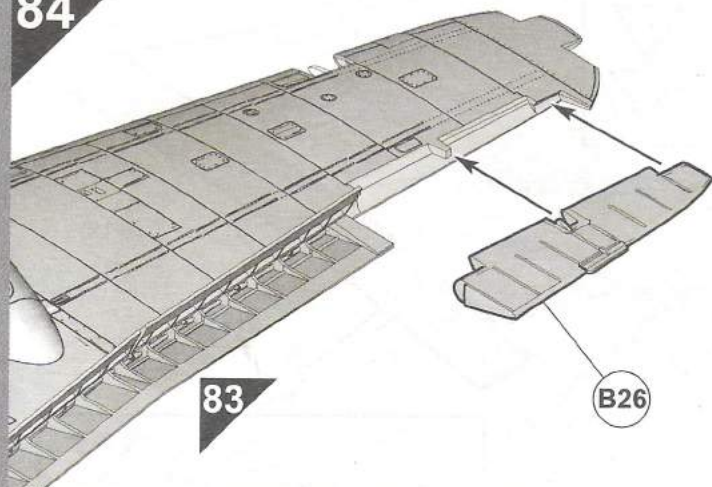

85

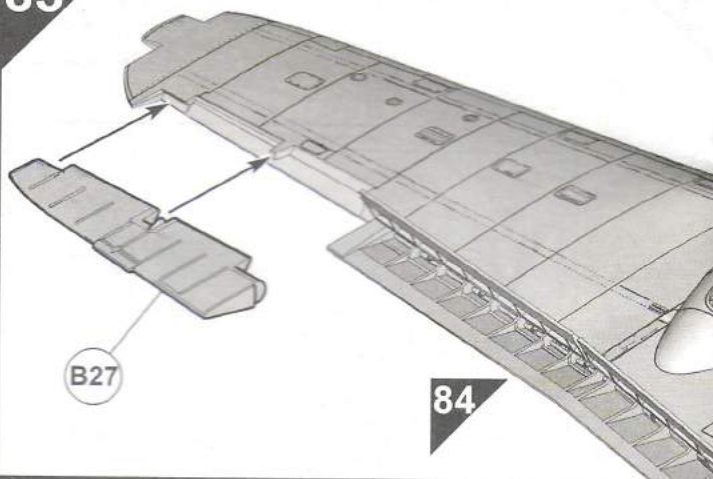

86

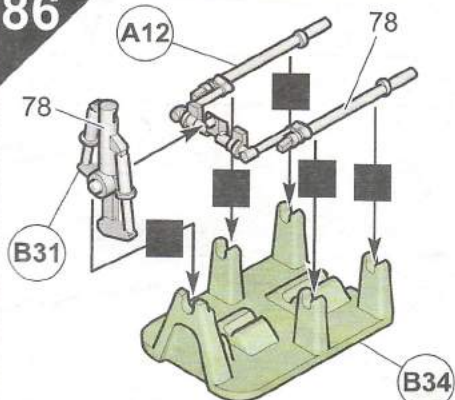

Note: use part B34 as a jig to hold and support the assembly of the turret. Do not glue any parts to the jig.

87

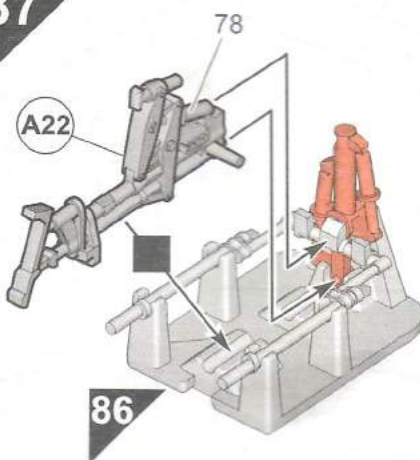

88

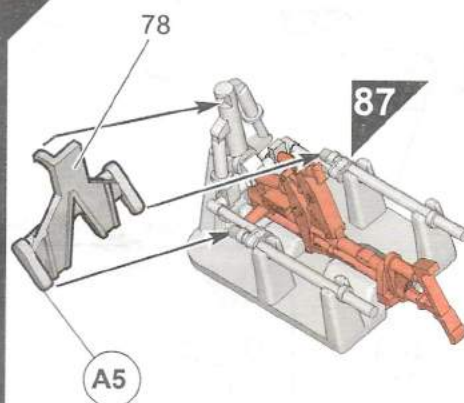

89

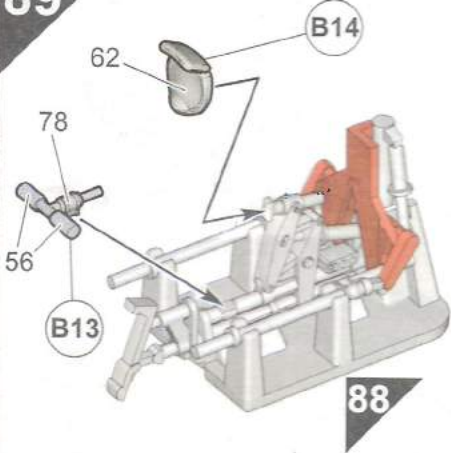

90

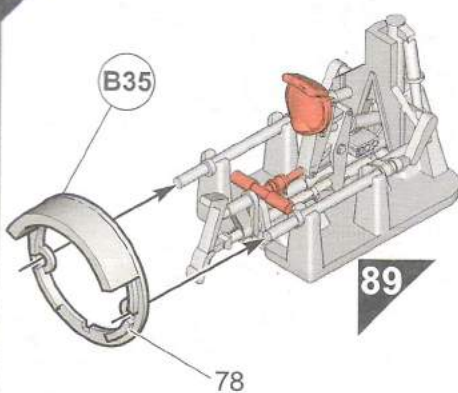

91

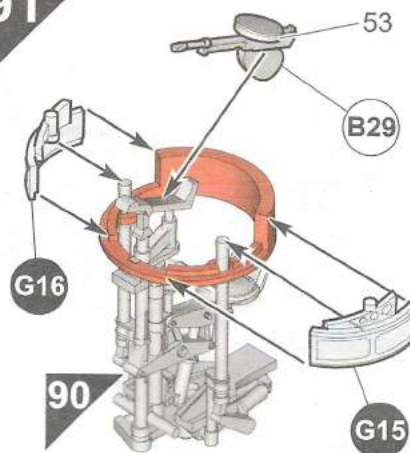

92

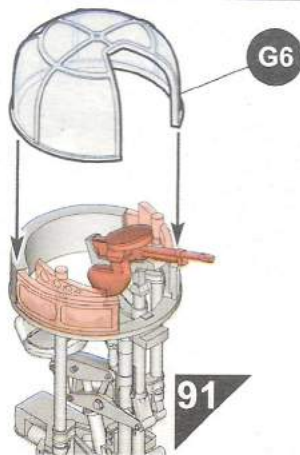

93

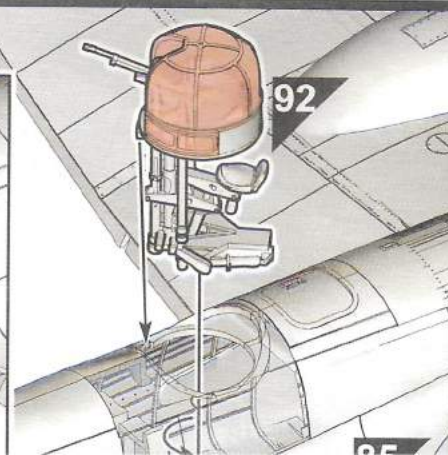
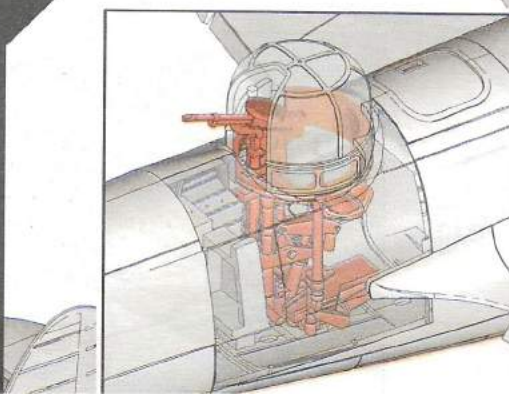

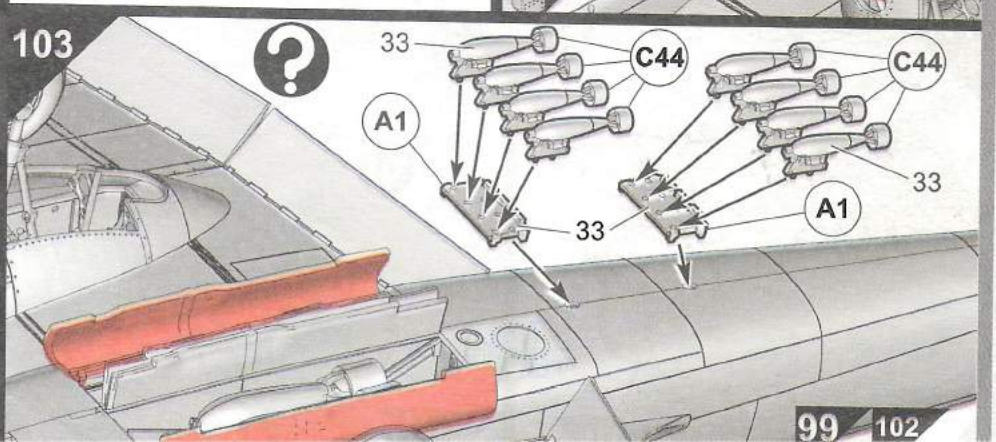
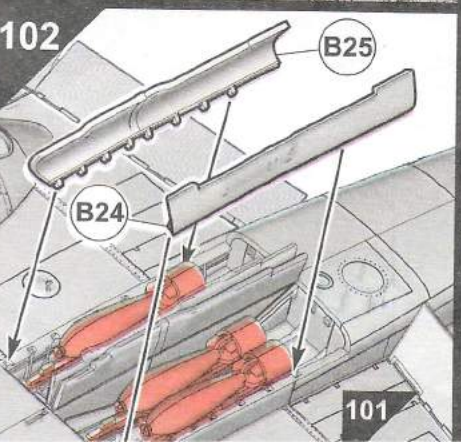
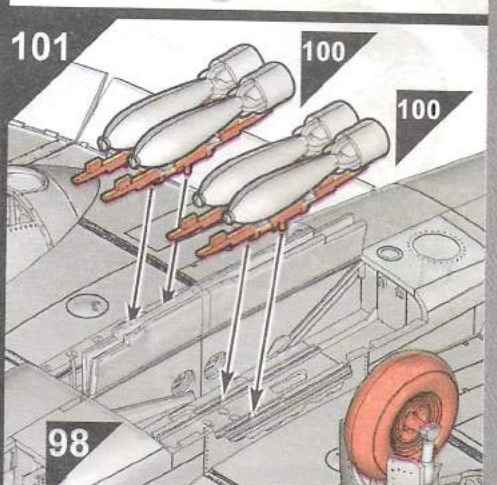
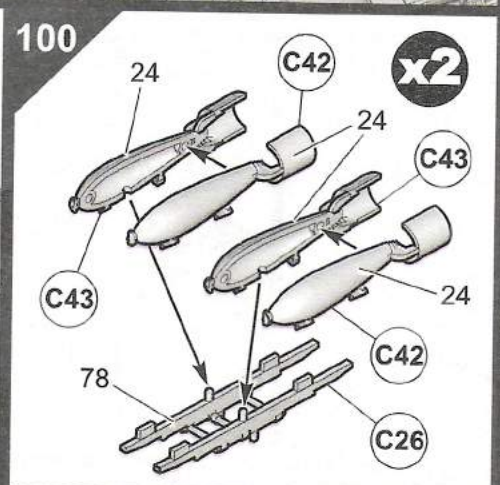
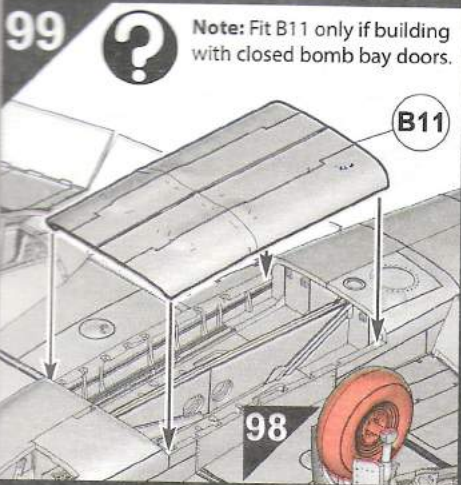
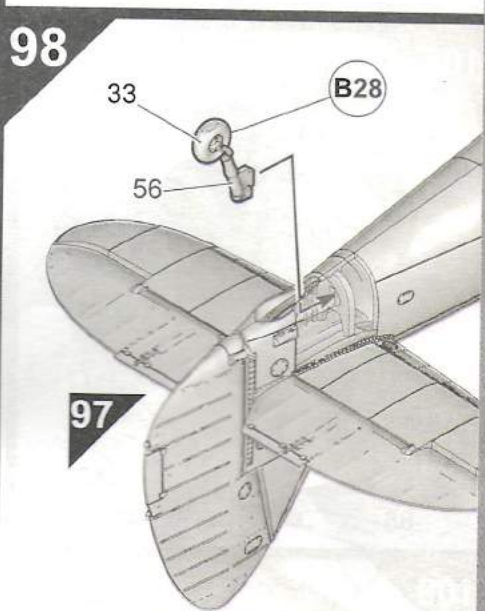
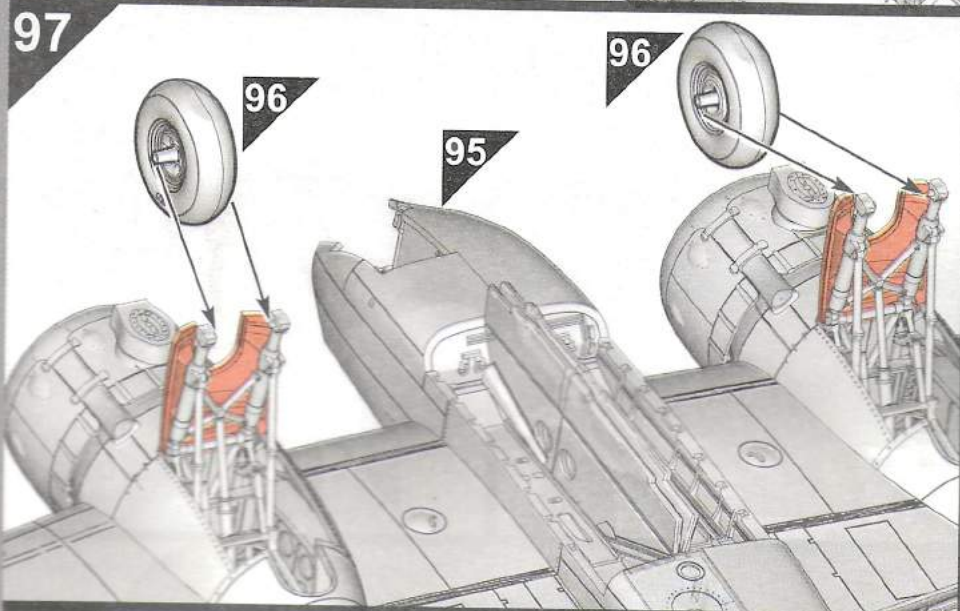
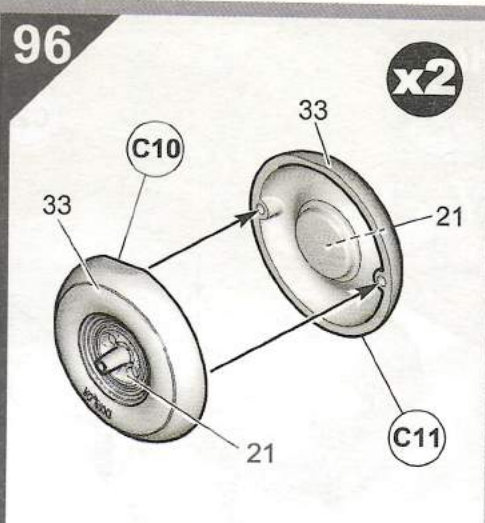
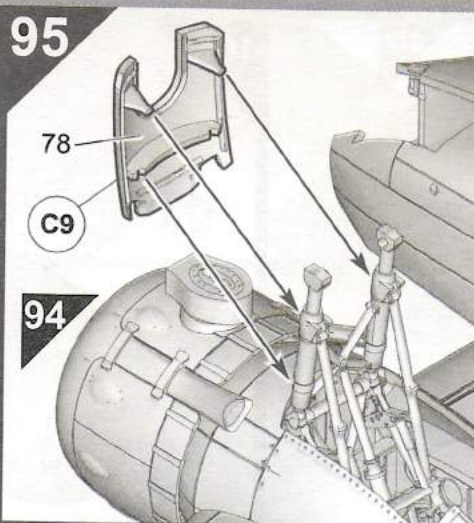
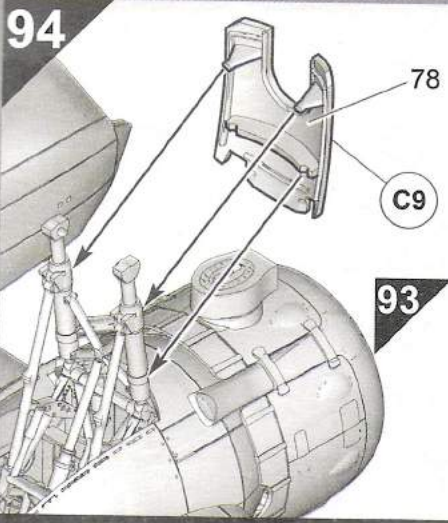

104

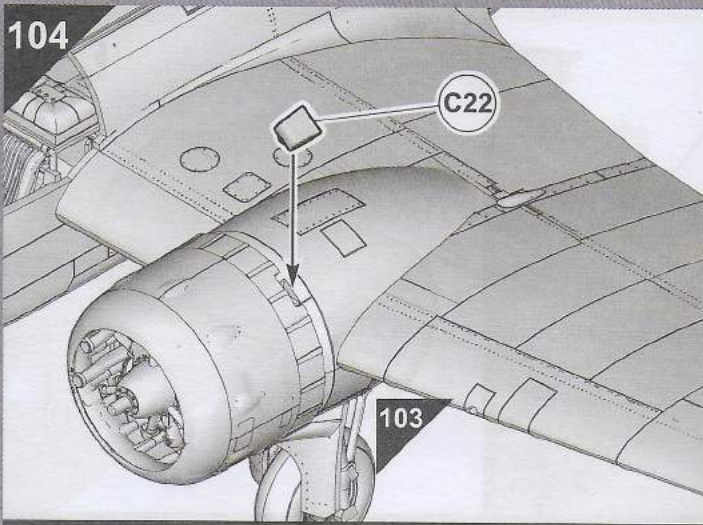

105

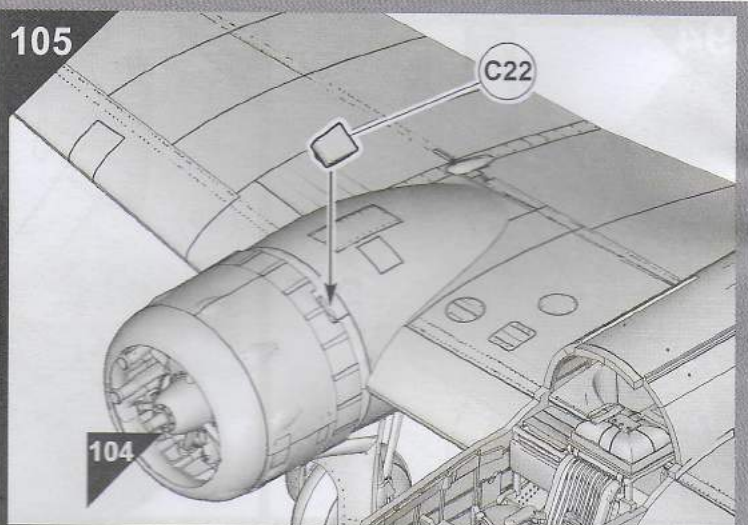

106

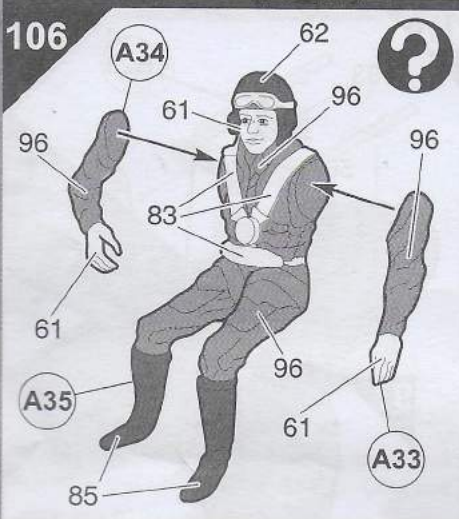

107

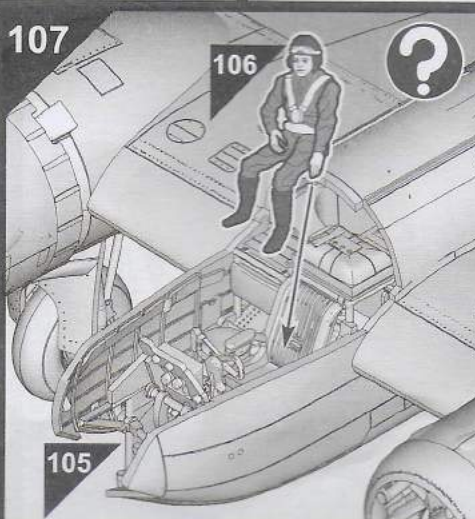

108

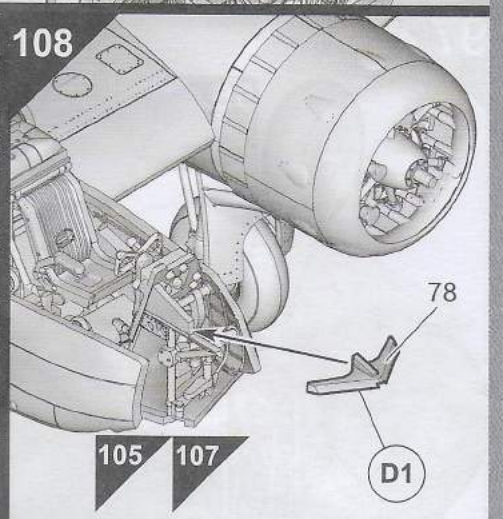

109

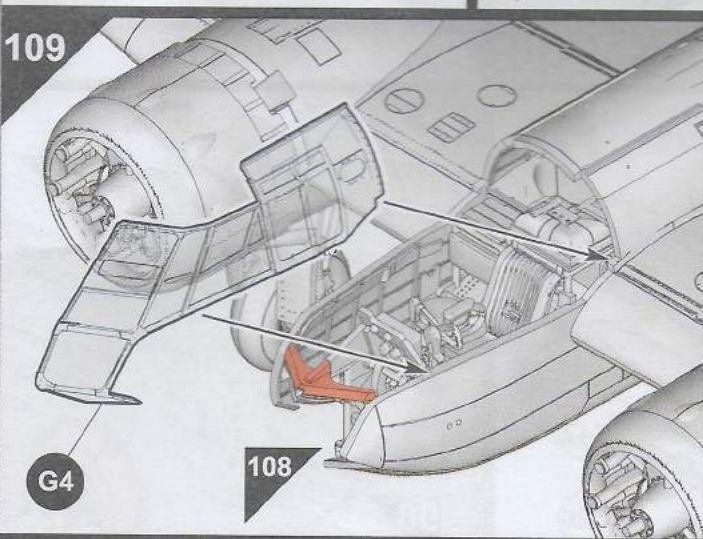

110

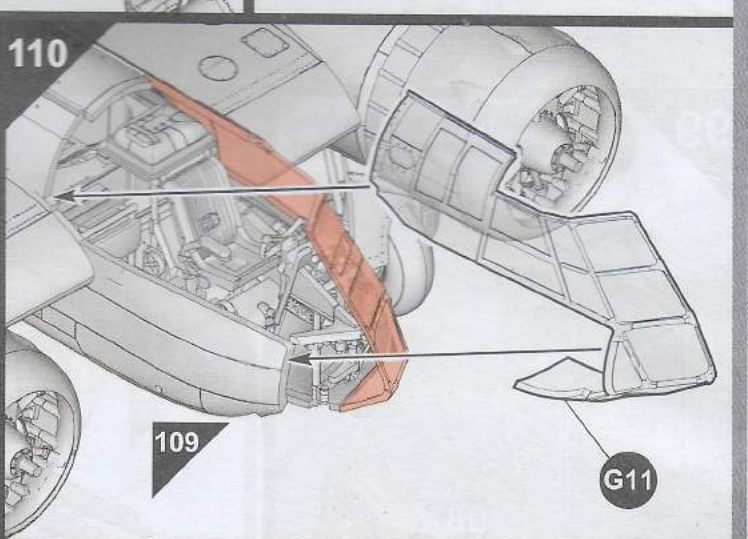

111

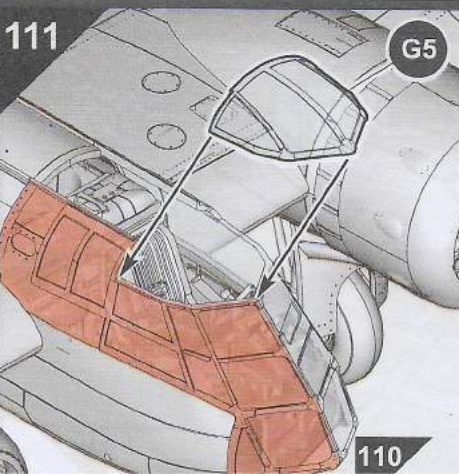

112

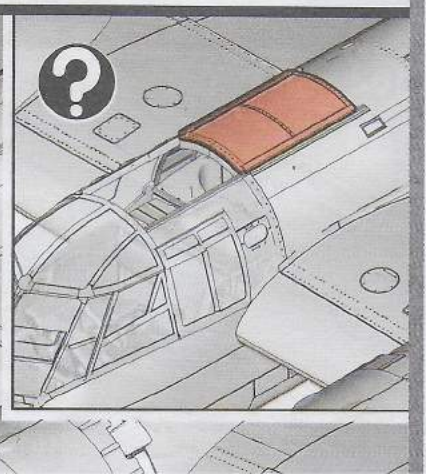
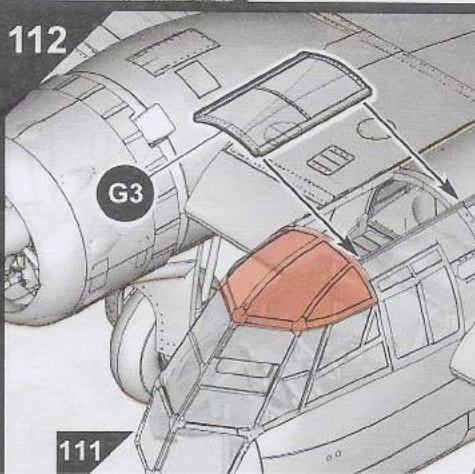

113

x2

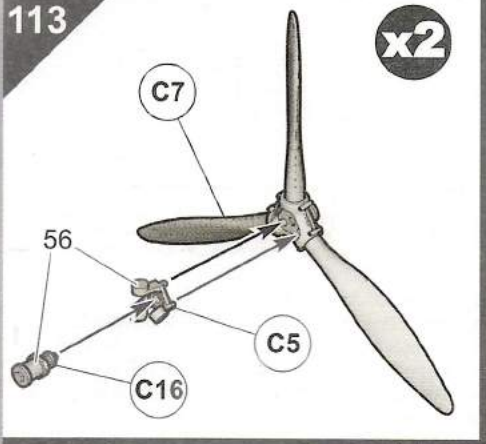

114

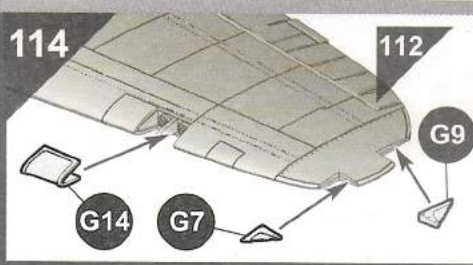

115

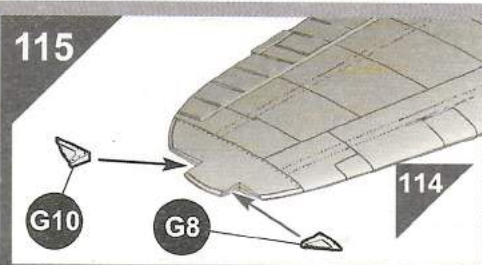

116

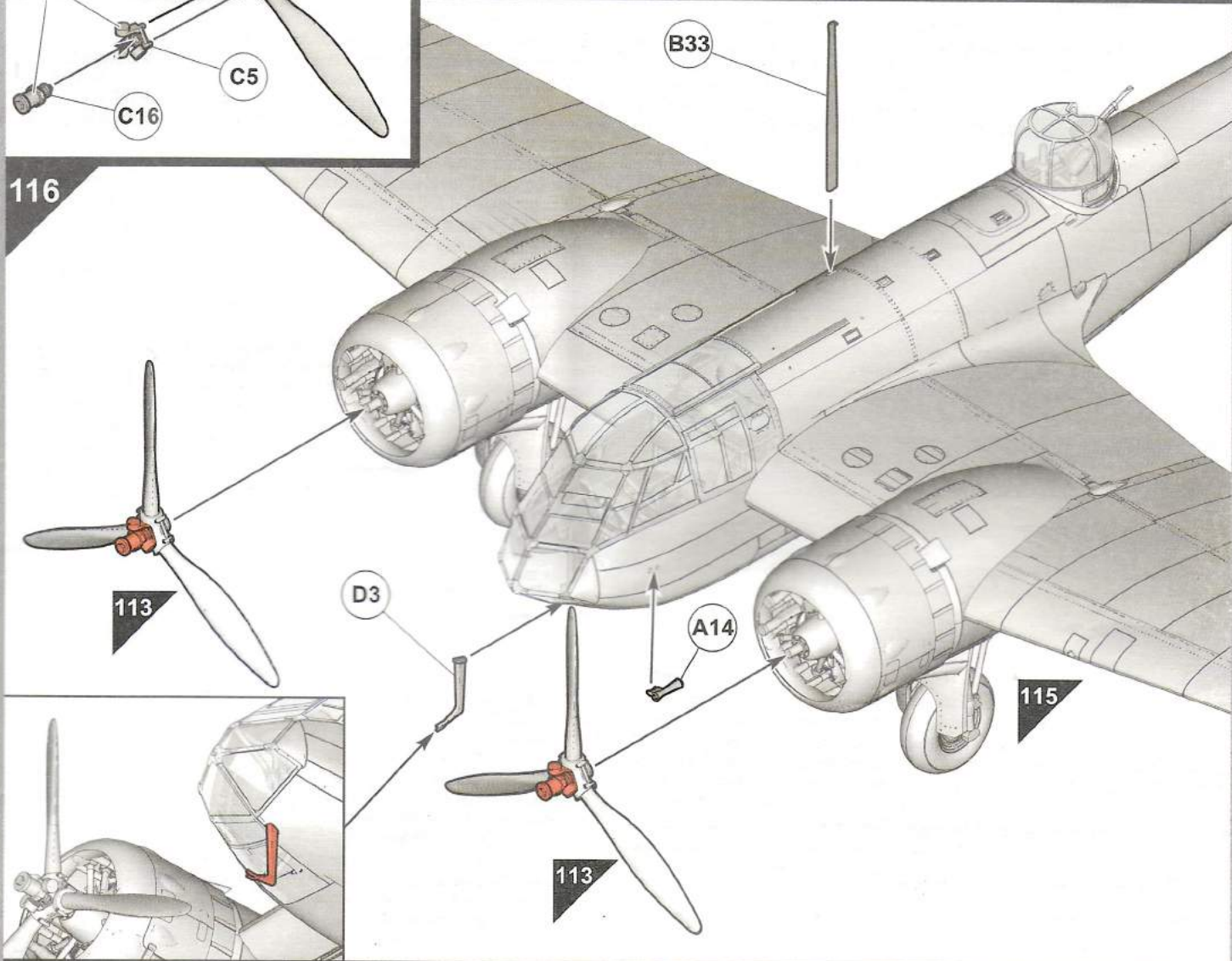

117

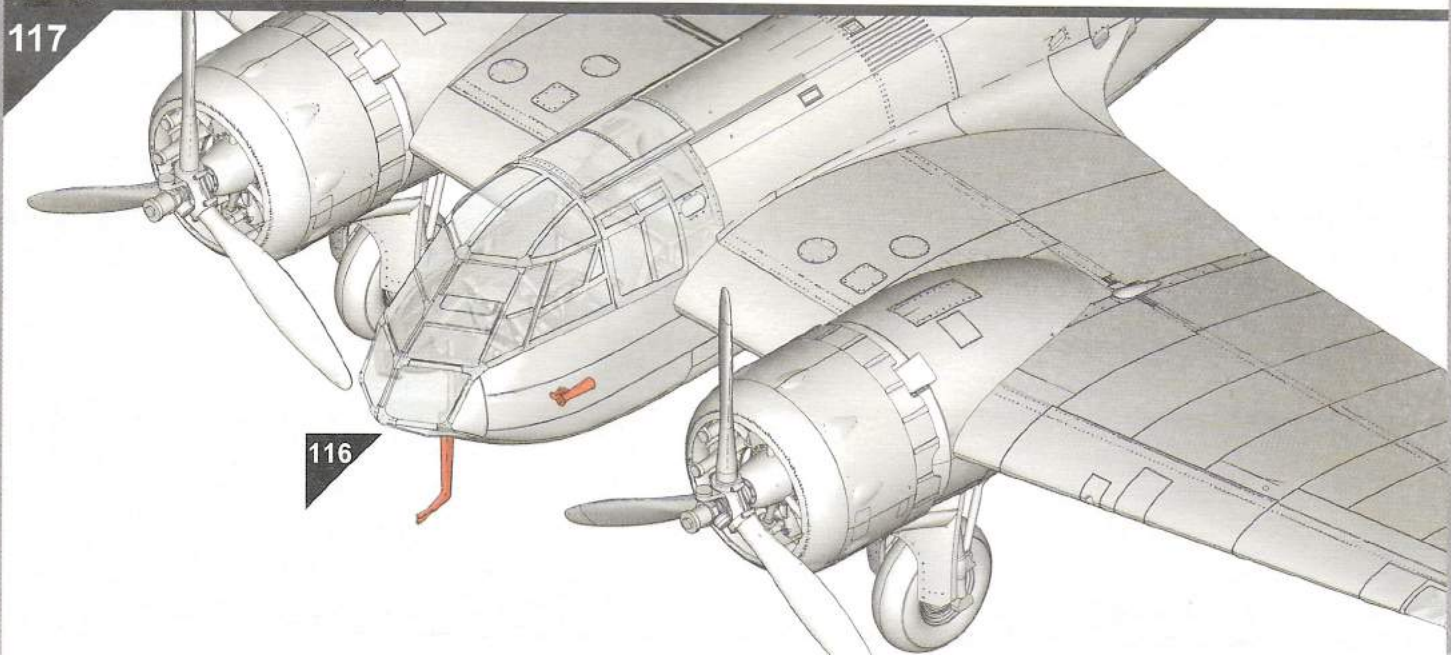

▲ Bristol Blenheim Mk.I No. 211 Squadron, Royal Air Force, Menidi, Greece, 1941.

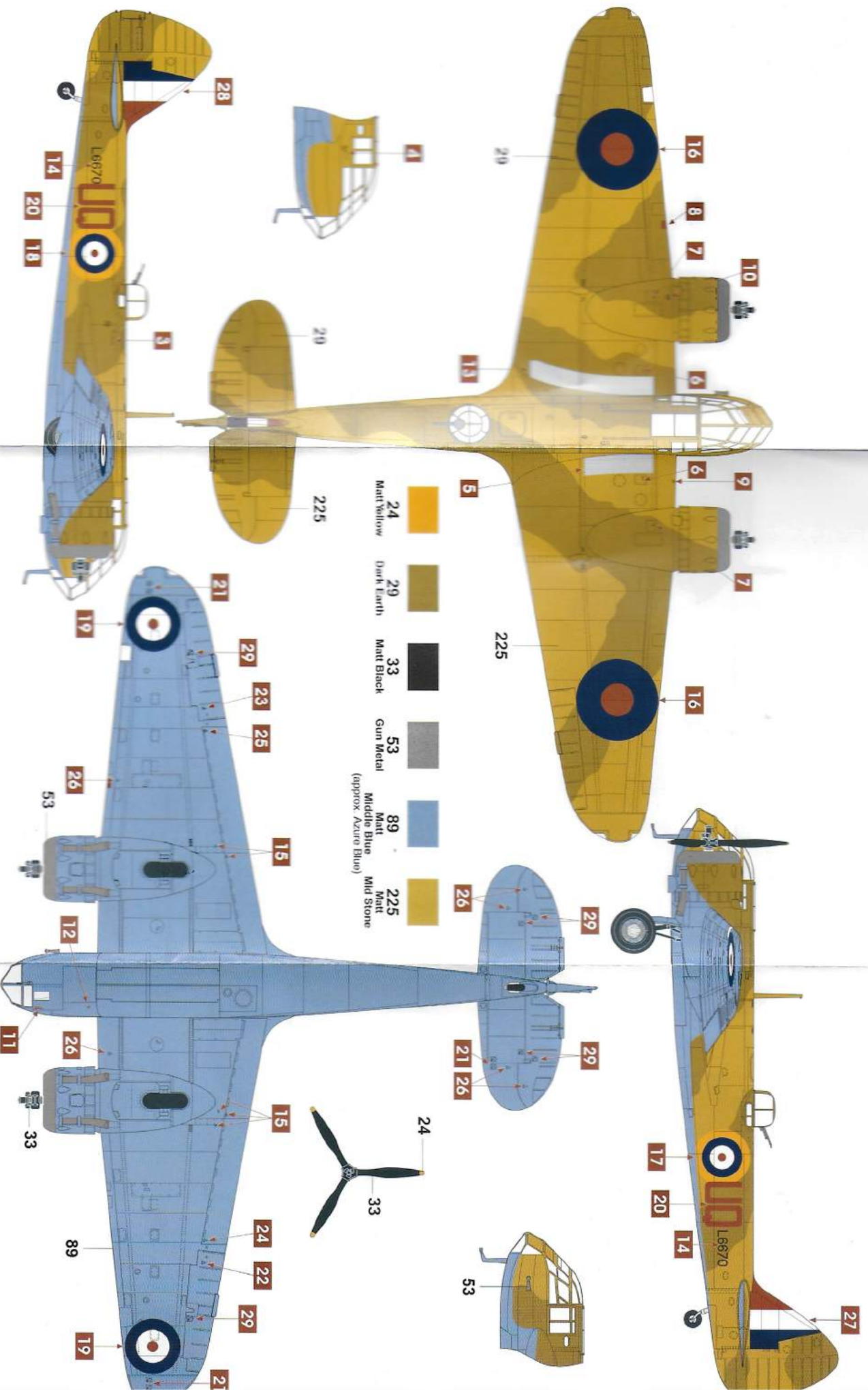

- 5
- 24 Matt Yellow
- 29 Dark Earth
- 33 Matt Black
- 53 Gun Metal
- 89 Middle Blue (approx. Azure Blue)
- 225 Matt Stone

Bristol Blenheim Mk.I
 No. 90 Squadron, Royal Air Force Bicester, Oxfordshire, England, autumn 1938.

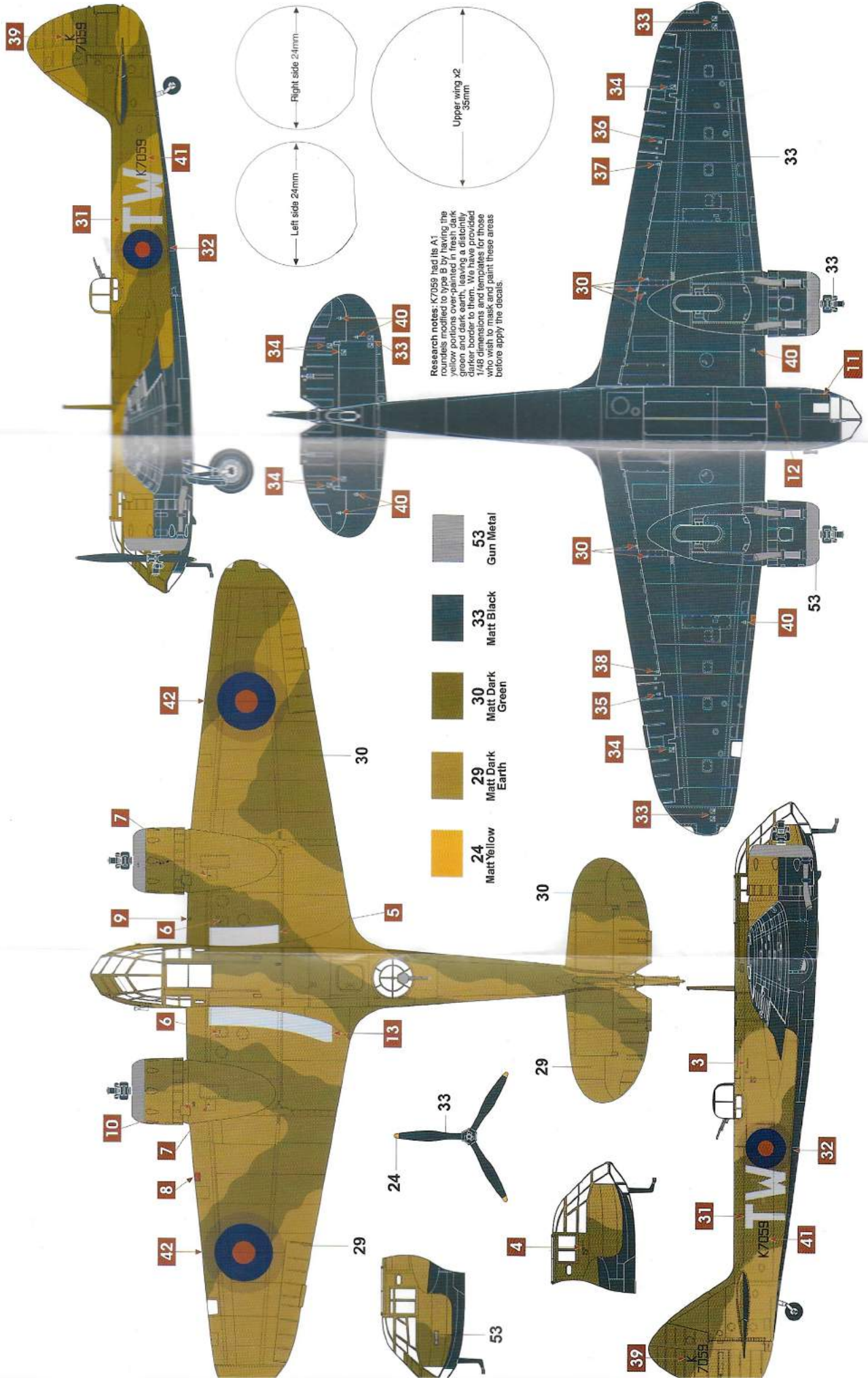

Research notes: K7059 had its A1 roundels modified to type B by having the red and blue outer rings a slightly darker shade than the original. We have provided 1/48 dimensions and templates for those who wish to mask and paint these areas before apply the decals.