



KIT 5310

85531000200

# BLUE ANGELS' A-4 SKYHAWK



The A-4 Skyhawk was designed as a small light weight jet attack aircraft capable of operating from aircraft carriers. The Skyhawk was used extensively during the war in Vietnam where it gained a reputation for being rugged and reliable. A-4's were also used by the Blue Angels flight demonstration team. The Blue Angels are well known the world over for their impressive performances of precision aerobatics. Flying in tight formation, these four outstanding U.S. Navy flyers captivate their audiences with breath-taking maneuvers.

Your Monogram model features an open or closed canopy with detailed cockpit and pilot, two optional external fuel tanks, center bomb pylon with six bombs and two wing mounted missiles and decals to build any one of the four aircraft from the Blue Angels team of 1978 or A-4E Skyhawk of LVDR John S. McCain, VA-45 Klansmen, USS Forestal, June 1967.



\* REPEAT SEVERAL TIMES  
\* A REPETER PLUSIEURS FOIS



\* REPEAT PROCEDURE  
\* RÈPÈTEZ LE PROCÈDE



\* OPTIONAL PARTS  
\* PIÈCES EN OPTION



\* DECAL

\* DECAL COMANIE



\* ASSEMBLY CAUTION  
\* ATTENTION D ASSEMBLEE



\* CEMENT TOGETHER  
\* A COLLER



\* REMOVE AND THROW AWAY  
\* A RETIRER ET JETER



\* DO NOT CEMENT  
\* NE PAS COLLER

## READ THIS BEFORE YOU BEGIN

- \* Study the assembly drawings.
- \* Each plastic part is identified by a number.
- \* In the assembly drawings, some parts will be marked by a star (★) to indicate chrome plated plastic.
- \* For better paint and decal adhesion, wash the plastic parts in a mild detergent solution. Rinse and let air dry.
- \* Check the fit of each piece before cementing in place.
- \* Use only cement for polystyrene plastic.
- \* Scrape plating and paint from areas to be cemented.
- \* Allow paint to dry thoroughly before handling parts.
- \* Any unused parts may be discarded.

## DECAL APPLICATION INSTRUCTIONS

1. Cut desired decal from sheet.
2. Dip decal in water for a few seconds.
3. Place wet decal on paper towel.
4. Wait until decal is movable on paper backing.
5. Place decal in position on model, face up and slide backing away.
6. Press out air bubbles with a soft damp cloth.
7. Milkiness that may appear is for better decal adhesion and will dry clear. Wipe away any excess adhesive.
8. Do not touch decal until fully dry.
9. Allow the decals 48 hours to dry before applying clear coat.

**NOTE:** Decals are compatible with setting solutions or solvents.

## LIRE CE QUI SUIT AVANT DE COMMENCER

- \* Etudier les schémas de montage.
- \* Chaque pièce en plastique est identifiée par un numéro.
- \* Sur les schémas de montage, certaines pièces sont marquées d'une étoile (★) pour indiquer qu'elles sont en plastique chromé.
- \* Pour une meilleure prise de la peinture et des autocollants, laver les pièces en plastique avec une solution détergente peu concentrée. Les rincer et les laisser sécher à l'air.
- \* Vérifier que chaque pièce s'ajuste bien avant de la coller en place.
- \* N'utiliser que de la colle pour polystyrène.
- \* Gratter les parties à coller pour enlever le chrome et la peinture.
- \* Laisser la peinture bien sécher avant de manipuler les pièces.
- \* Toute pièce inutilisée peut être jetée.

## DIRECTIVES D'APPLICATION DES AUTOCOLLANTS

1. Découper l'autocollant désiré de la feuille.
2. Tremper l'autocollant dans de l'eau pendant quelques secondes.
3. Placer l'autocollant mouillé sur une serviette en papier.
4. Attendez que l'autocollant puisse être déplacé sur son support en papier.
5. Mettre l'autocollant en position sur le modèle face sur le dessus et faire glisser le support pour l'enlever.
6. Appuyer avec un chiffon doux humide pour éliminer les bulles d'air.
7. La substance laiteuse qui peut apparaître est destinée à améliorer l'adhésion de l'autocollant et devient incolore au séchage. Essuyer pour enlever tout excédent d'adhésif.
8. Ne pas toucher l'autocollant tant qu'il n'est pas bien sec.
9. Laisser l'autocollant sécher pendant 48 heures avant d'appliquer une couche transparente.

**REMARQUE:** Les autocollants sont compatibles avec les solutions de fixation ou les solvants.

This paint guide is provided to complete this kit as shown on the box.

Ce guide de peintures est fourni pour reproduire le modèle réduit qui apparaît sur la boîte.

Flat Black	Noir mat
Light Gull Gray	Gris clair
Dark Gray	Gris foncé
Aluminum	Aluminium
Green	Vert
Insignia Red	Rouge emblémé
Steel	Acier
Yellow	Jaune
Blue Angel Blue	Blue angélique
Orange	Orange
Red	Rouge
Gloss White	Blanc brillant
Olive Drab	Gris vert

If you have any questions or comments, call our hotline at: **(800) 833-3570** or, please write to:

Revell Inc Consumer Service Department, 1850 Howard Street Unit A, Elk Grove Village, Illinois 60007

Be sure to include the plan number (85531000200), part number, description, your return address and phone number.

Visit our website: [www.revell.com](http://www.revell.com)

# 1

# COCKPIT / FUSELAGE ASSEMBLY

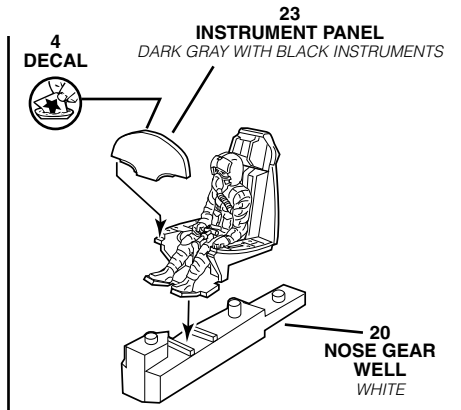
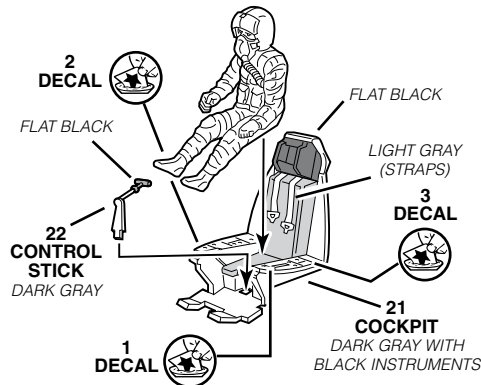
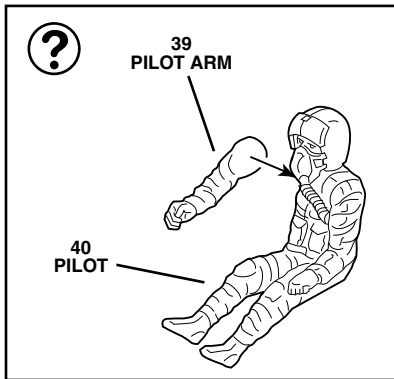

**PAINT NOTE:**  
PILOT - WHITE OR DARK GREEN HELMET WITH BLACK TRIM, OLIVE DRAB SUIT, DARK GRAY MASK AND HOSE, BLACK BOOTS, LIGHT GRAY CHUTE STRAPS WITH SILVER BUCKLES, BLACK GLOVES.

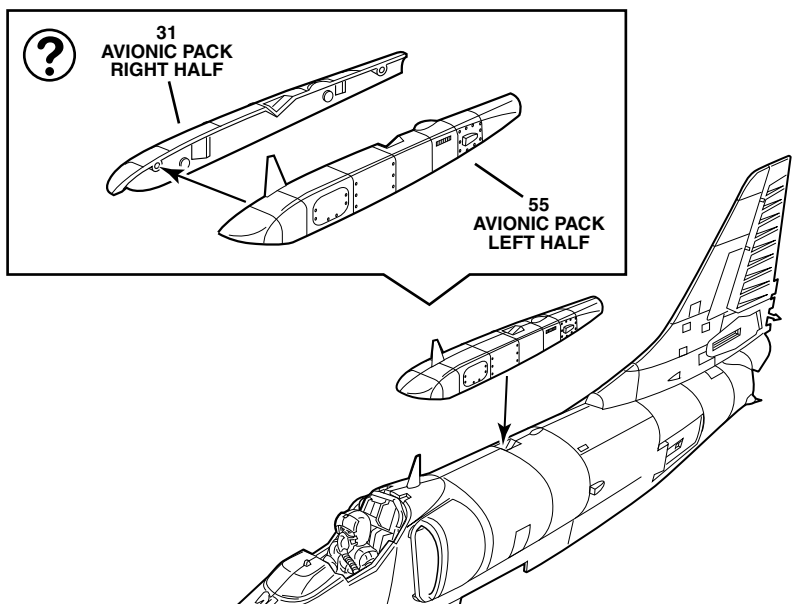
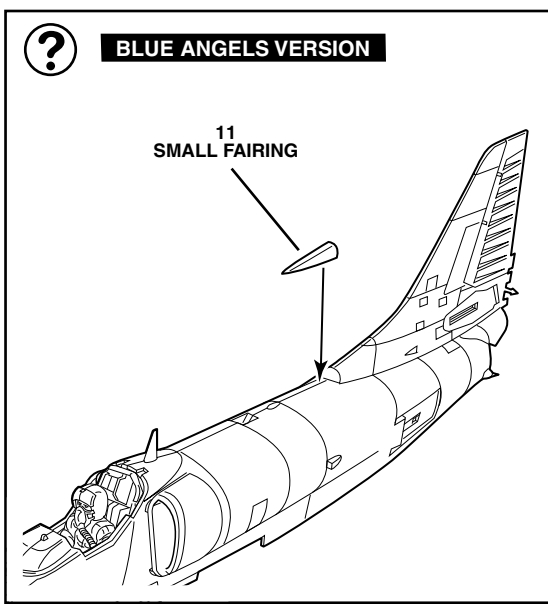
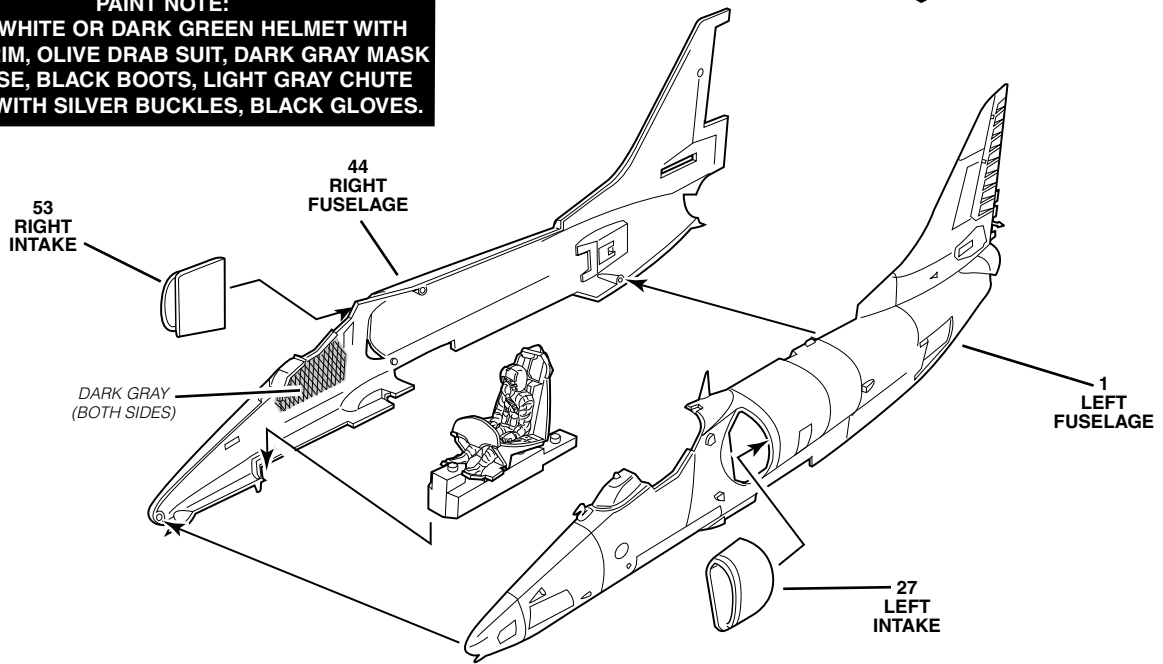

# 2

# WING ASSEMBLY

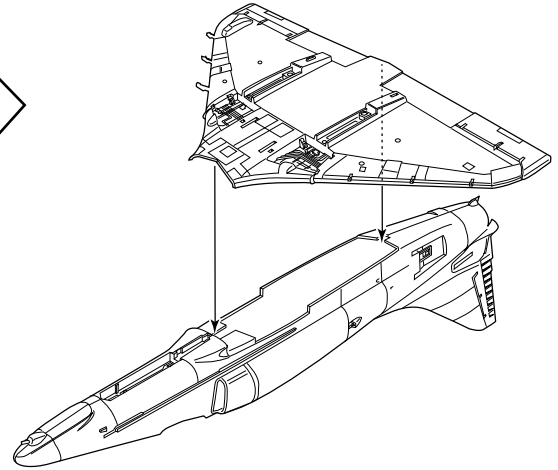
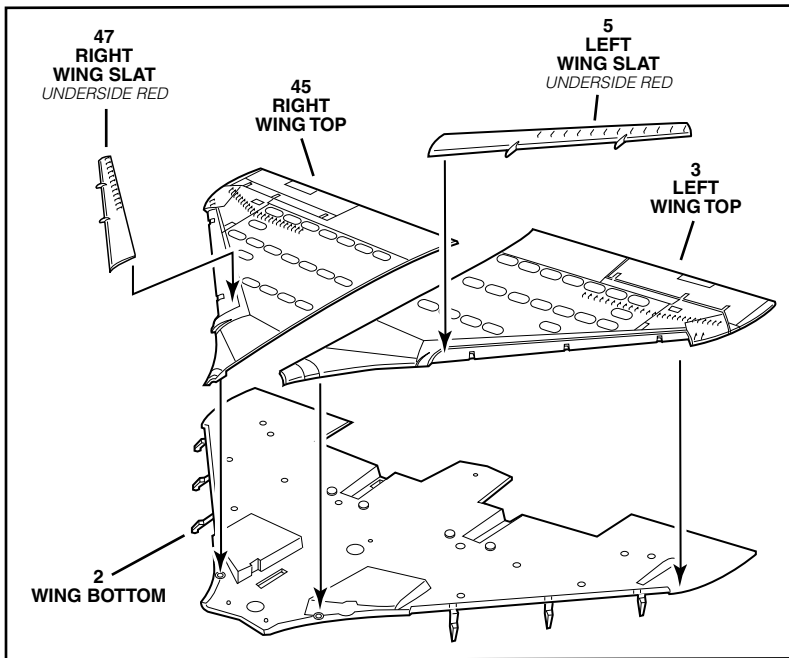

# 3

# MAIN WHEEL ASSEMBLY

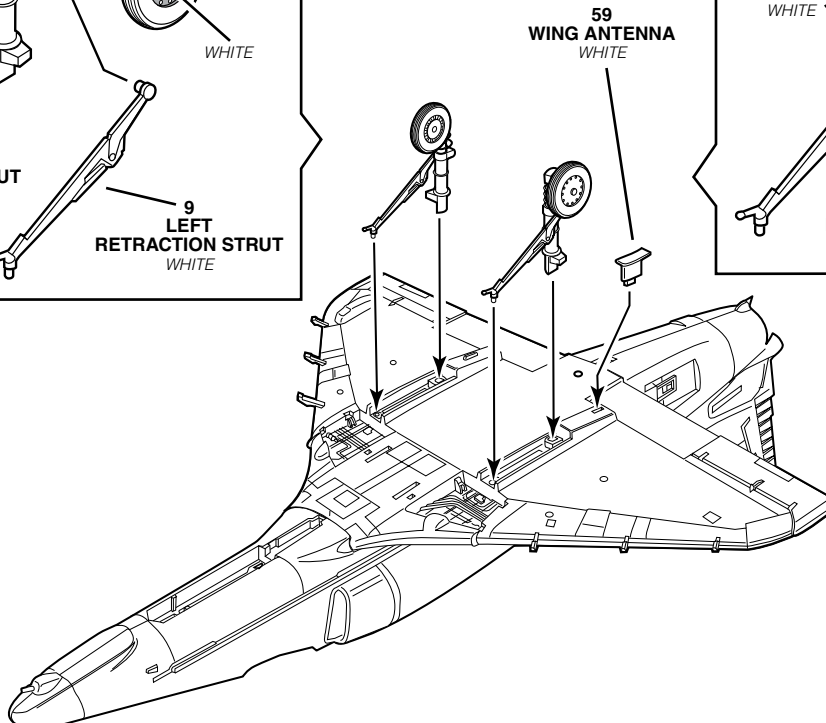
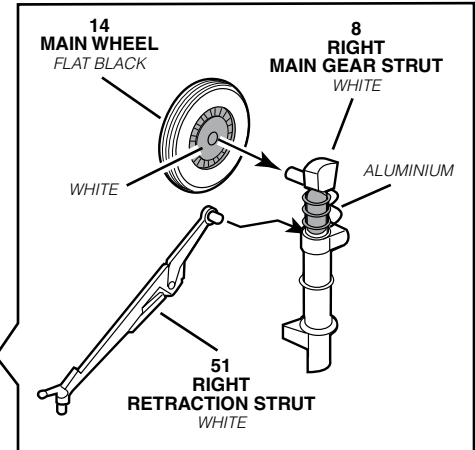
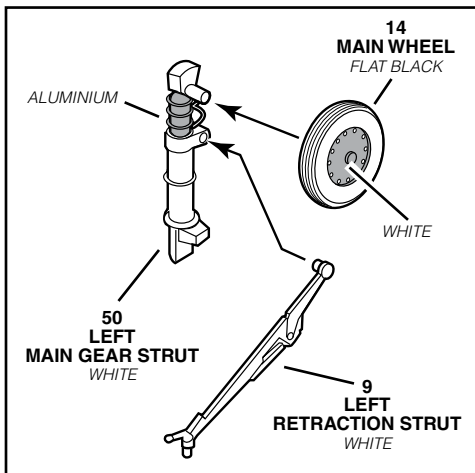

# 4

# DOOR / FLAP ASSEMBLY

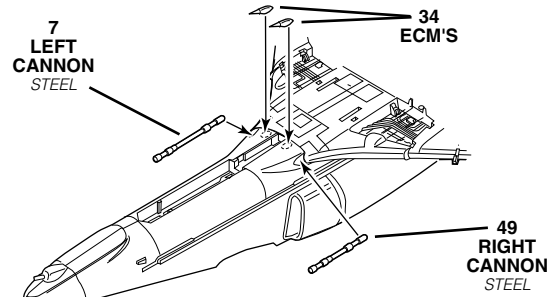
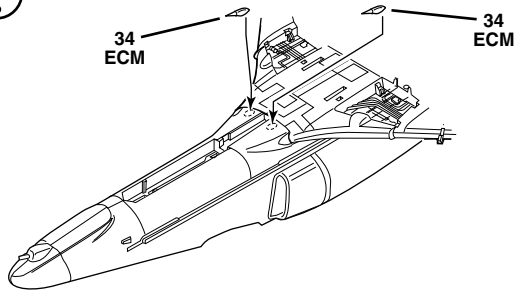
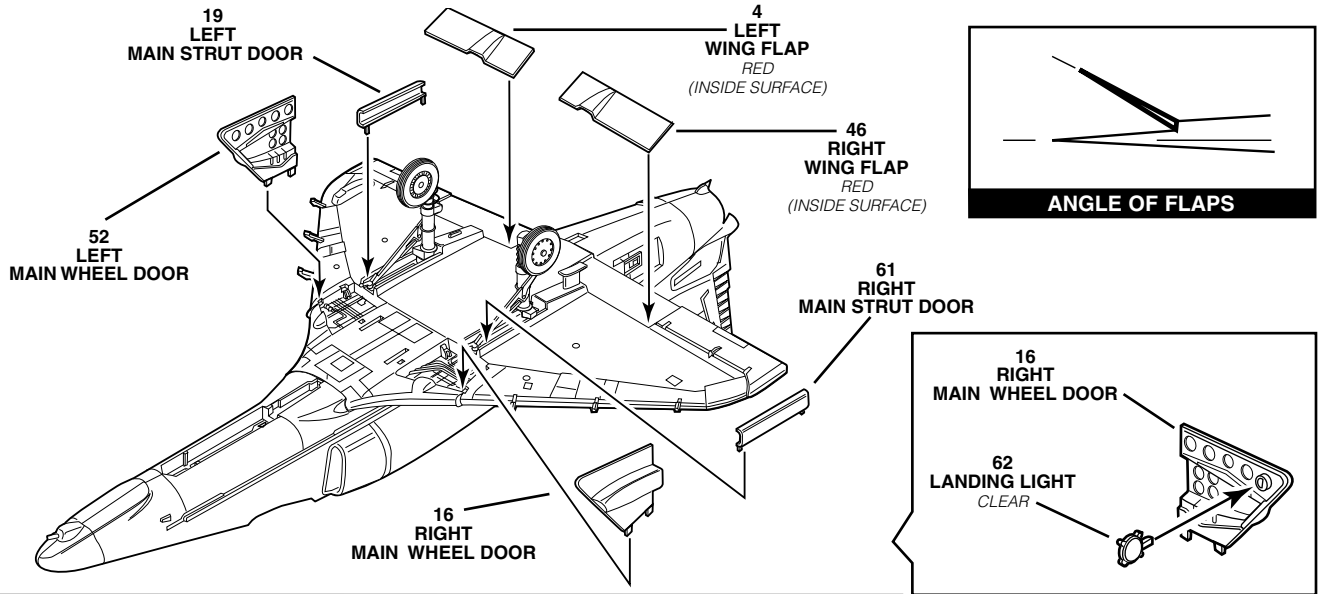

# 5

# NOSE WHEEL ASSEMBLY

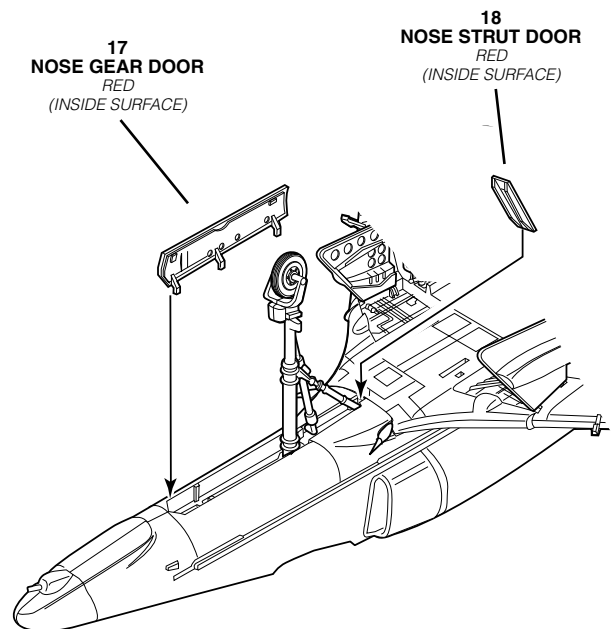
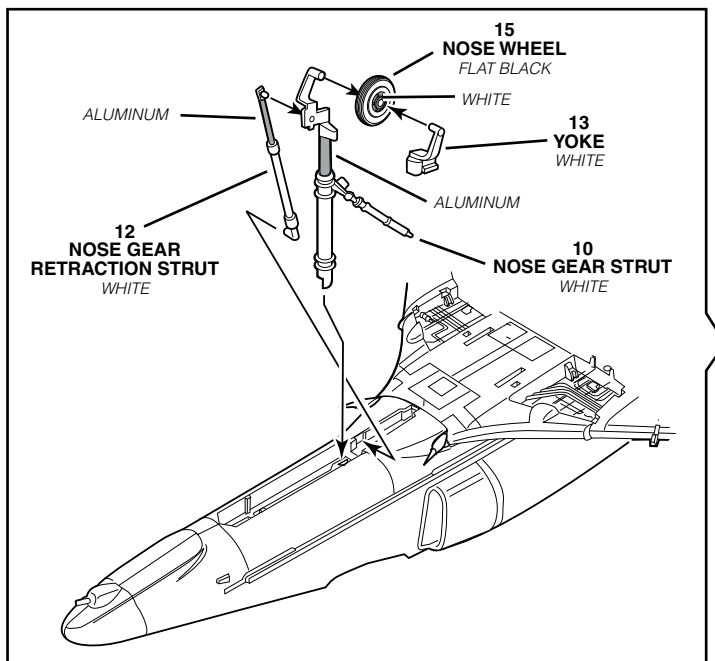

# 6

# TAIL ASSEMBLY

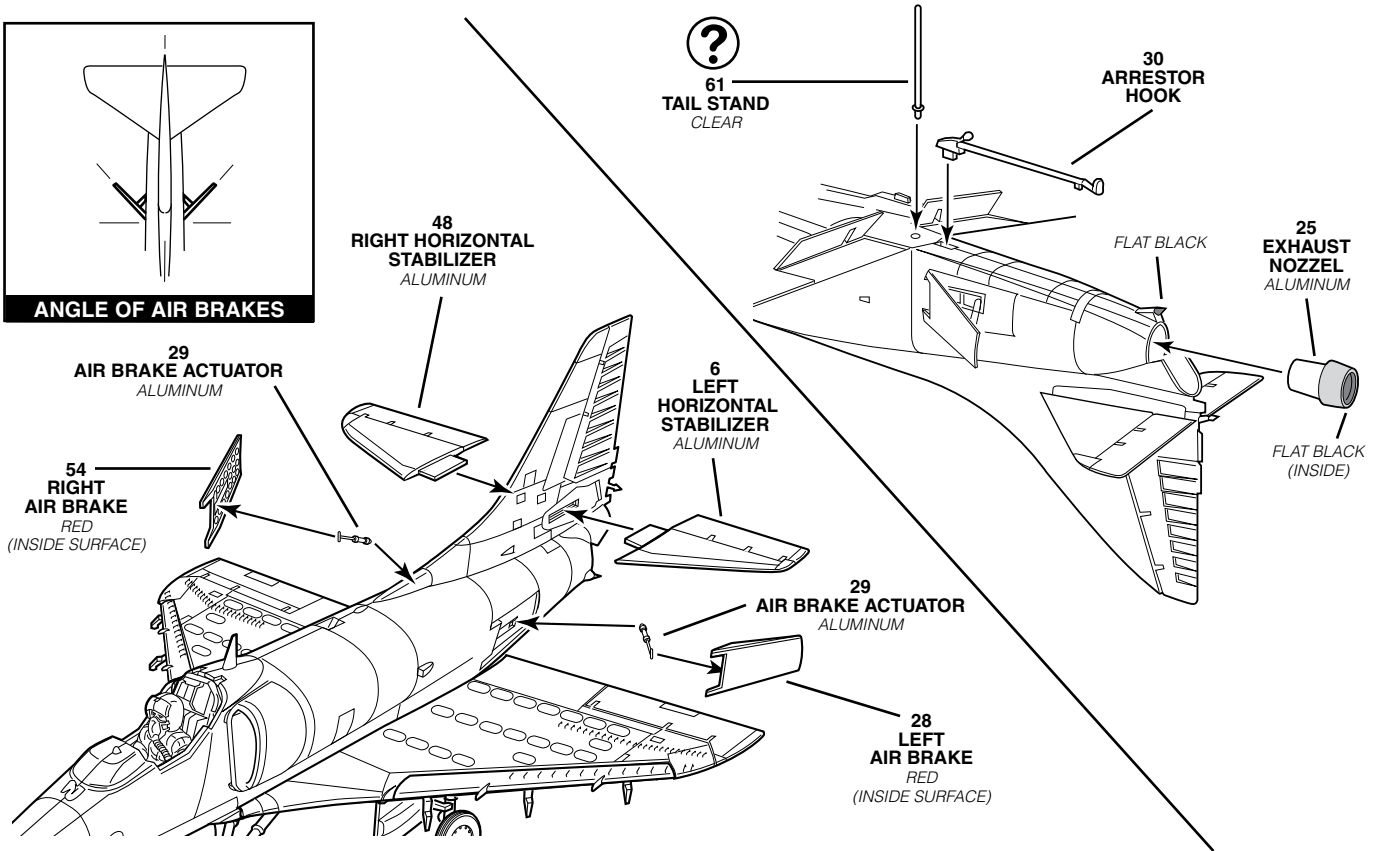
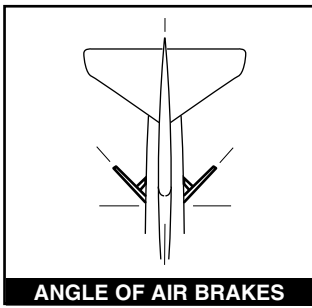

# 7

# CANOPY ASSEMBLY

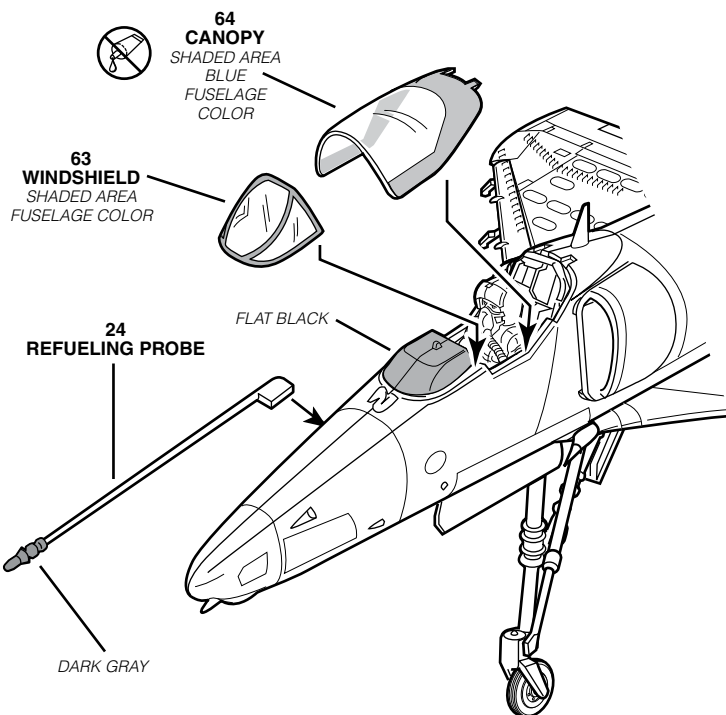

**CLOSED**

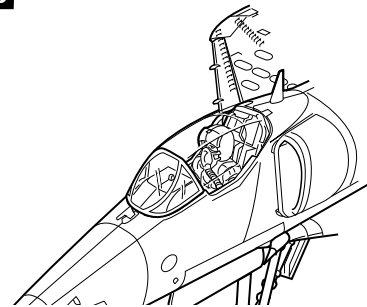

**OPEN**

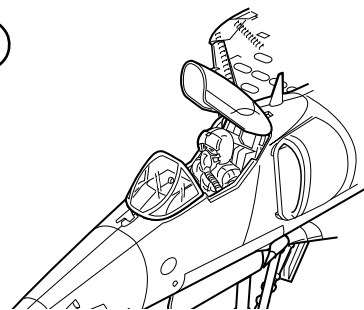

# ARMAMENT ASSEMBLY

2X

58 FUEL TANK BOTTOM  
WHITE

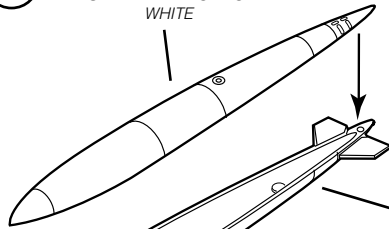

38 FUEL TANK TOP  
WHITE

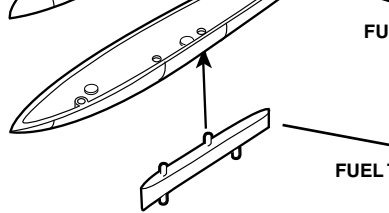

26 FUEL TANK PYLON  
WHITE

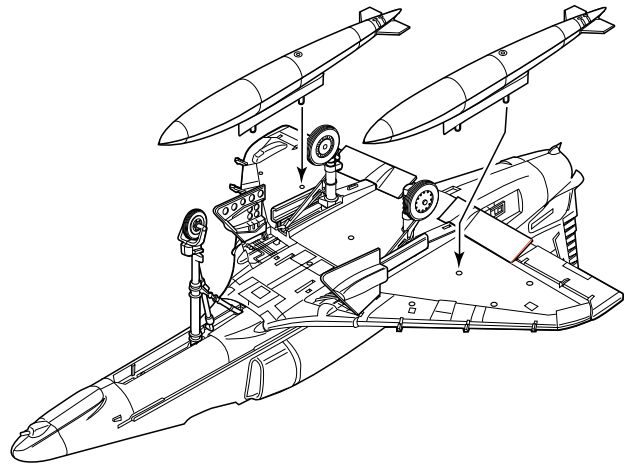

6X

57 BOMB HALF  
OLIVE DRAB

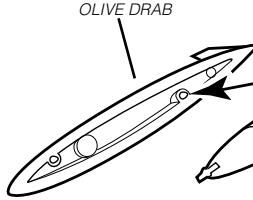

36 BOMB HALF  
WITH FINS  
OLIVE DRAB

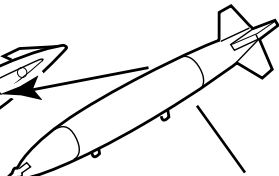

33 BOMB RACK  
WHITE

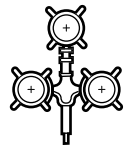
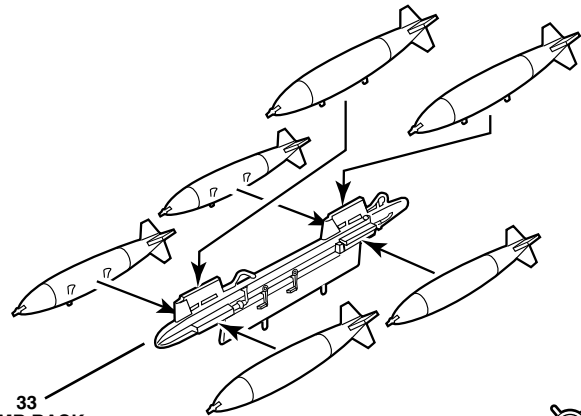

2X

37 MISSILE FIN  
WHITE

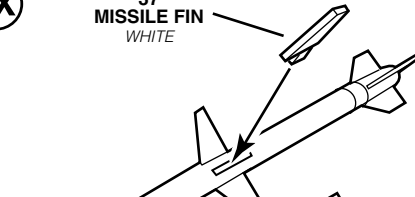

35 MISSILE HALF  
WITH FINS  
WHITE

56 MISSILE HALF  
WHITE

37 MISSILE FIN  
WHITE

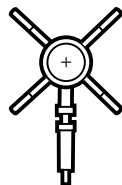

32 MISSILE PYLON  
WHITE

32 MISSILE PYLON  
WHITE

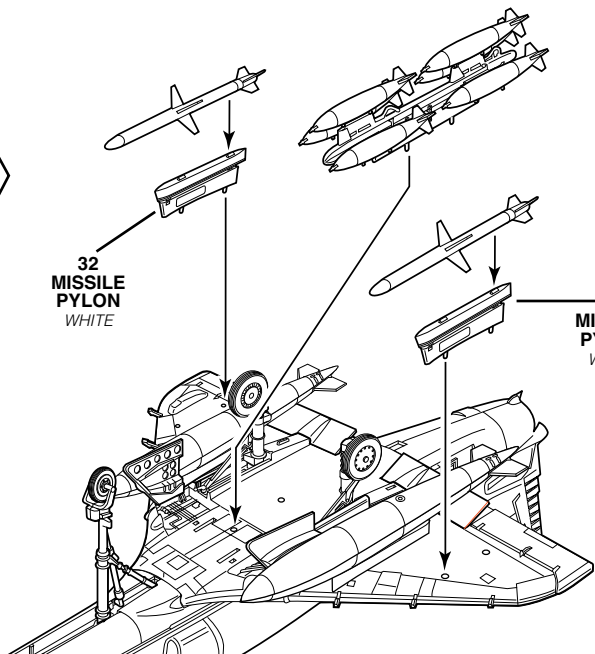

## Blue Angels A-4E Skyhawk 1978

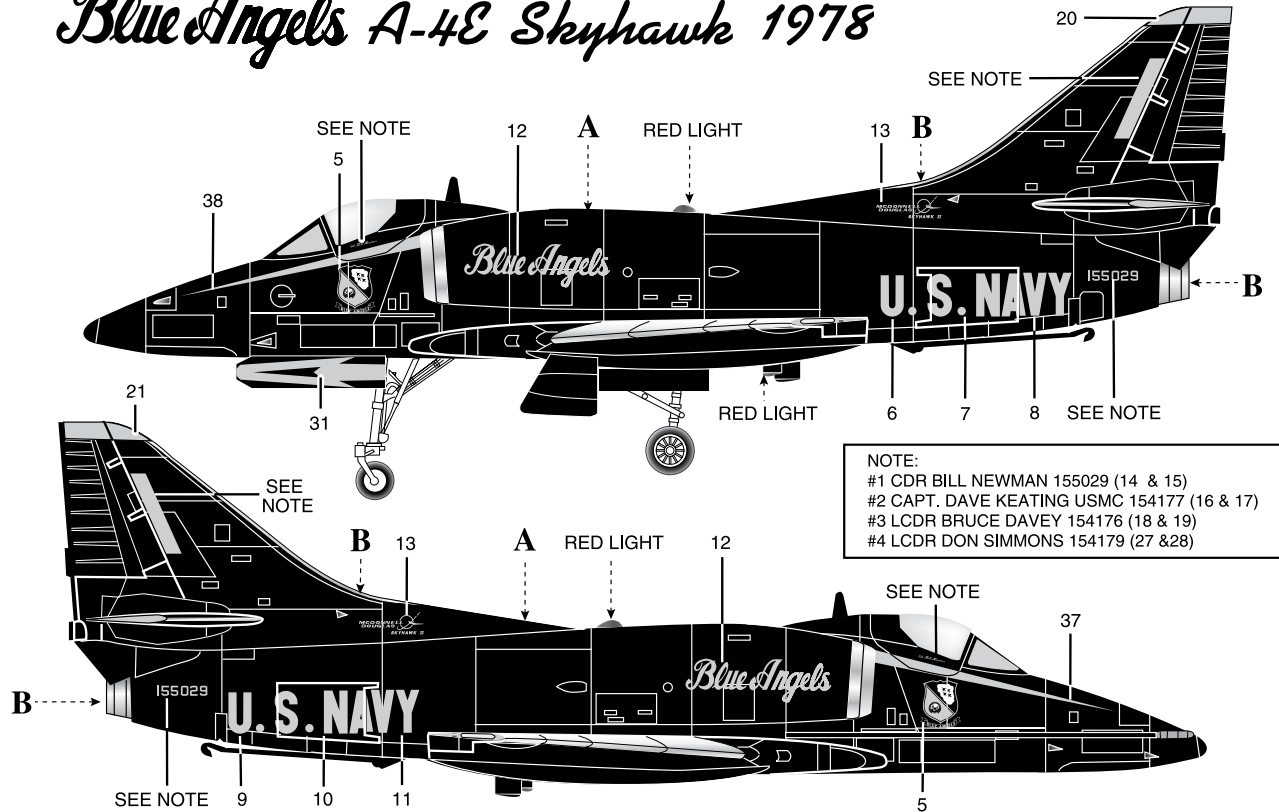

NOTE:  
 #1 CDR BILL NEWMAN 155029 (14 & 15)  
 #2 CAPT. DAVE KEATING USMC 154177 (16 & 17)  
 #3 LCDR BRUCE DAVEY 154176 (18 & 19)  
 #4 LCDR DON SIMMONS 154179 (27 & 28)

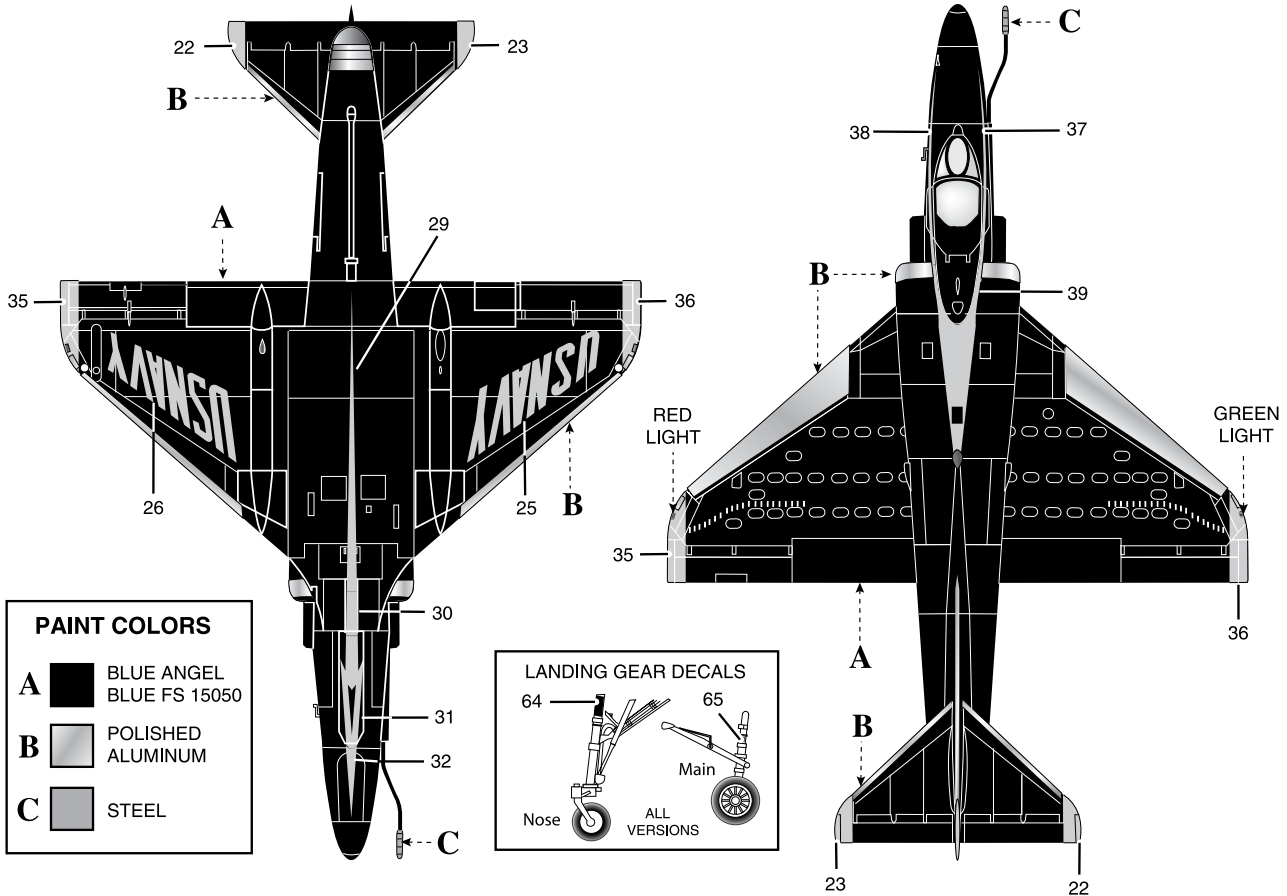

PAINT COLORS	
<b>A</b>	BLUE ANGEL BLUE FS 15050
<b>B</b>	POLISHED ALUMINUM
<b>C</b>	STEEL

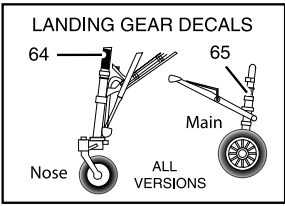

DOUGLAS A-4E SKYHAWK, BUNO, 149996, PILOT LCDR JOHN S. MCCAIN III  
VA-45 KLANSMEN, USS FORRESTAL, JUNE 1967

