**MORANE-SAULNIER M.S. 406**

1/32

**CZ****Morane Saulnier MS 406C.1**

V roce 1934 vypsalo francouzské Armée de l'Air soutěž na jednomístný stíhač s rychlostí 450 km/h a výzbrojí 1 až 2 kamony ráže 20 mm. Vítězem soutěže se stal letoun Morane Saulnier MS 405C.1. Vyrobeno bylo ale jen 16 kusů této verze a výroba přešla na upravenou verzi MS 406C.1. Tu poháněl motor H-S 12Y.31 a výzbroj tvořil kanon v ose vrtule a dva kulometry v křídle. Vyrobeno bylo 1064 kusů, včetně exportních. Na začátku války byly MS 406C.1 nejpočetnějším stíhacím typem, který měla Francie k dispozici. Výkonově převyšoval německé Bf 109D, ale zaostával za nejmodernější verzí Bf 109E. Jednotky létající na MS 406C.1 byly dislokovány nejen na území Francie, ale i v severní Africe a v Indočíně. Na MS 406C.1 bojovali francouzští stíhači od začátku války až do porážky Francie. Spolu s nimi i českoslovenští a polští letci. Morany byly dále používány letectvem Armée de l'Air de l'Armistice. Několik jich používalo i letectvo Svobodných Francouzů. Dále se MS 406C.1 dostalo koupí do výzbroje Turecka, Finska a Švýcarska. Díky okupaci Francie se ukořistěné stroje dostaly do výzbroje Německa, Itálie a Chorvatska. Další stroje od Německa koupilo Finsko. Ve Finsku byla část MS 406C.1 upravena vestavěním ukořistěných sovětských motorů VK 105P na typ Mörkö Morane. Švýcarsko stavělo MS 406C.1 i v licenci a dále je vyvíjelo.

**Technická data:**

Rozpětí: 10,61 m, délka: 8,15 m, max. rychlost v 5000 m: 486 km/h, dolet: 1000 km, dostup: 9 850 m, výzbroj (francouzská): 1x kanon HS 404 (původně HS 9) ráže 20 mm, 2x kulomet MAC 1934 ráže 7,5 mm

**GB****Morane Saulnier MS 406C.1**

Armée de l'Air in 1934 excerpt a competition on single seat fighter capable of reaching 450 Kph and armed with 1 - 2 20 mm cannons. The competition winner was the Morane Saulnier MS 405C.1. Only 16 were produced and the production was then converted to modified version MS 406C.1. It was powered by H-S 12Y.31 engine and the armament consisted of cannon firing through the hollow engine's shaft and two wing mounted machine guns. At the outbreak of the war the MS 406C.1 was French most numerous type. It was more powerful than German Bf 109D but fell short to Bf 109E version. MS 406C.1 units were located in not only in France but also in Northern Africa and French Indochina. French fighter pilots used MS 406C.1 from the beginning till the defeat of the France. Together with them also fought Czechoslovakian and Polish fighter pilots. Further Moranes were used by Armée de l'Air de l'Armistice. The Free French Air Force also used several of them. MS 406C.1 was further sold to Turkey, Finland and Switzerland. When the France was occupied the German, Italian and Croatian Air Forces also included them as war prizes. Further machines Germany sold to Finland. By installing the Russian war prized engines VK 105P and marking the type to Mörkö Morane modified part of them. Switzerland still produced license built MS 406C.1 and further developed them.

**Technical data:**

Wingspan: 10,61 m, Length: 8,15 m, Max speed at 5000 m: 486 Kph, Flight radius: 1000 Km, Service Ceiling: 9850 m, Armament: 1x 20 mm HS 404 (former HS 9) cannon, 2x 7,5 mm MAC 1934 machine gun.



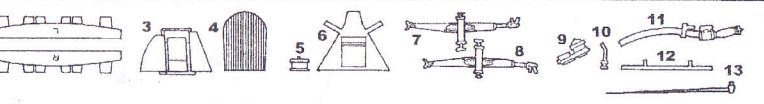
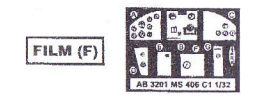
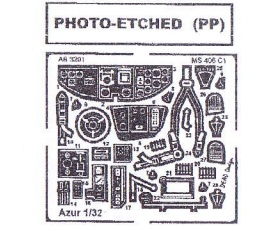
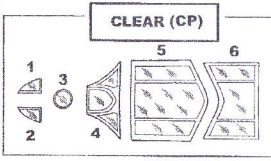
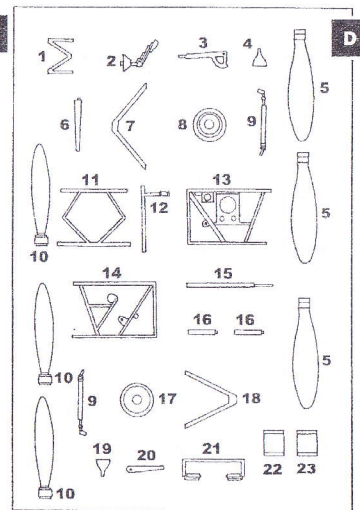
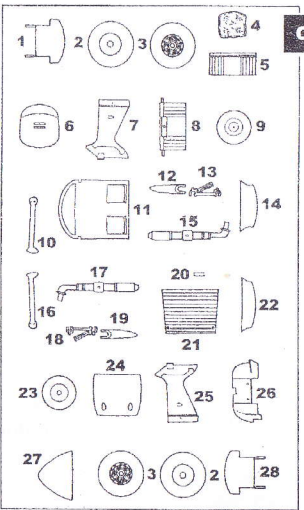
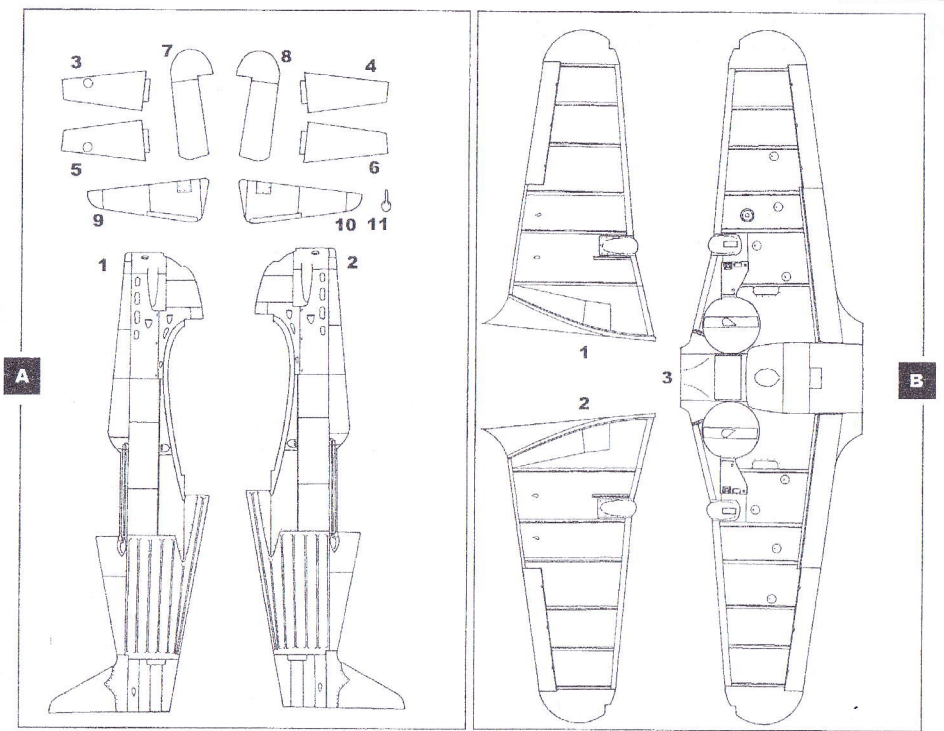

**POLYURETHAN (PUR)**  
 COLLE A METAL FOR GLUING USE CYANOACRYLATE GLUE

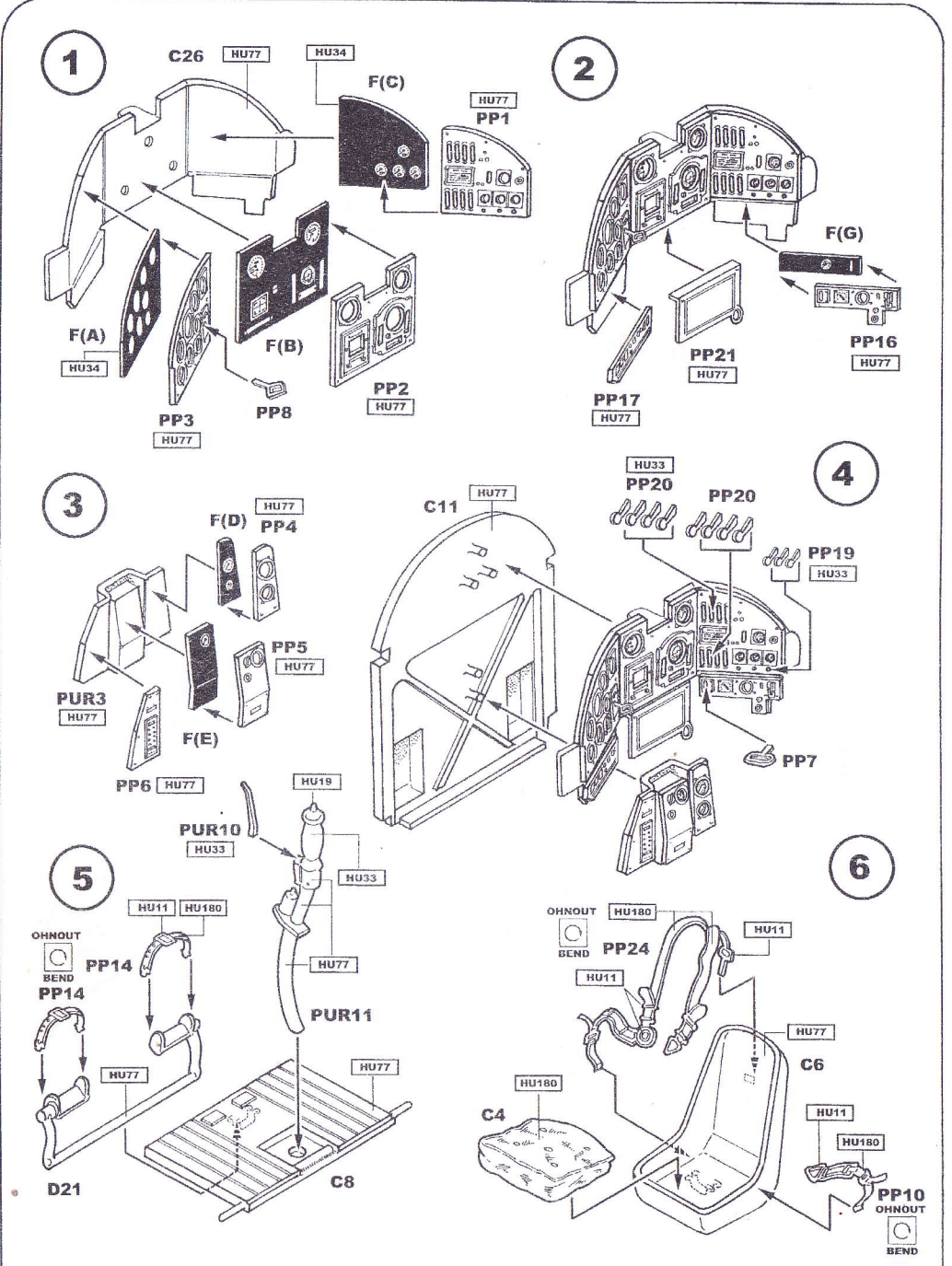



7

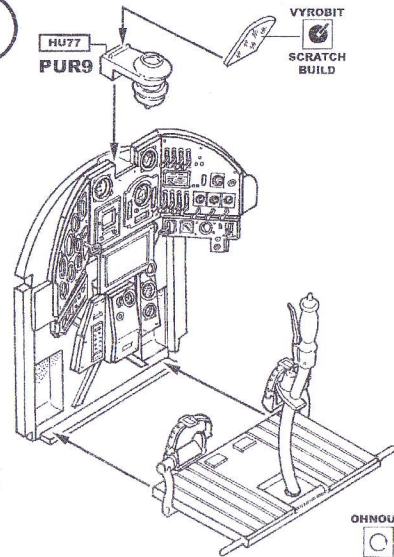

8

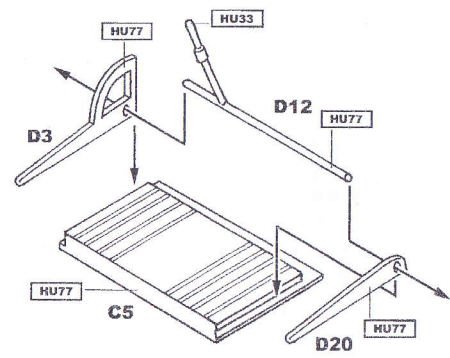

9

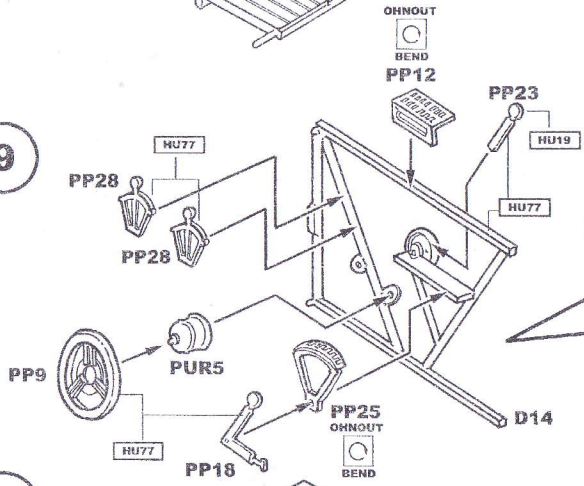

info

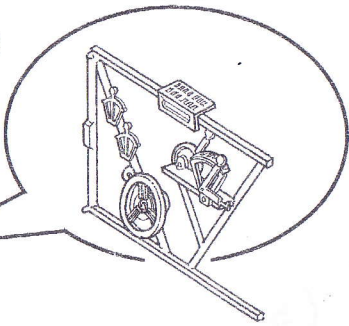

10

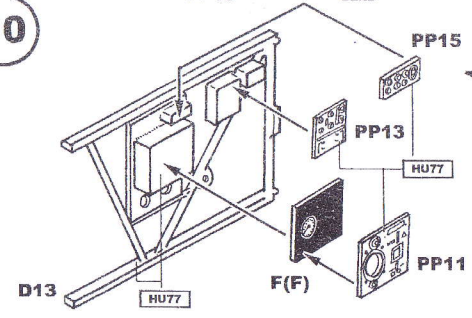

info

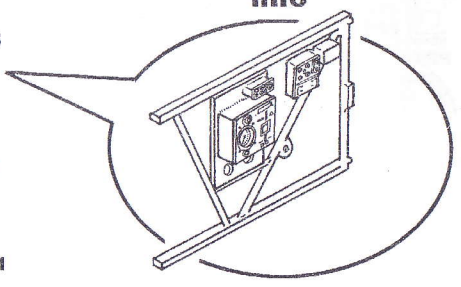

4

11

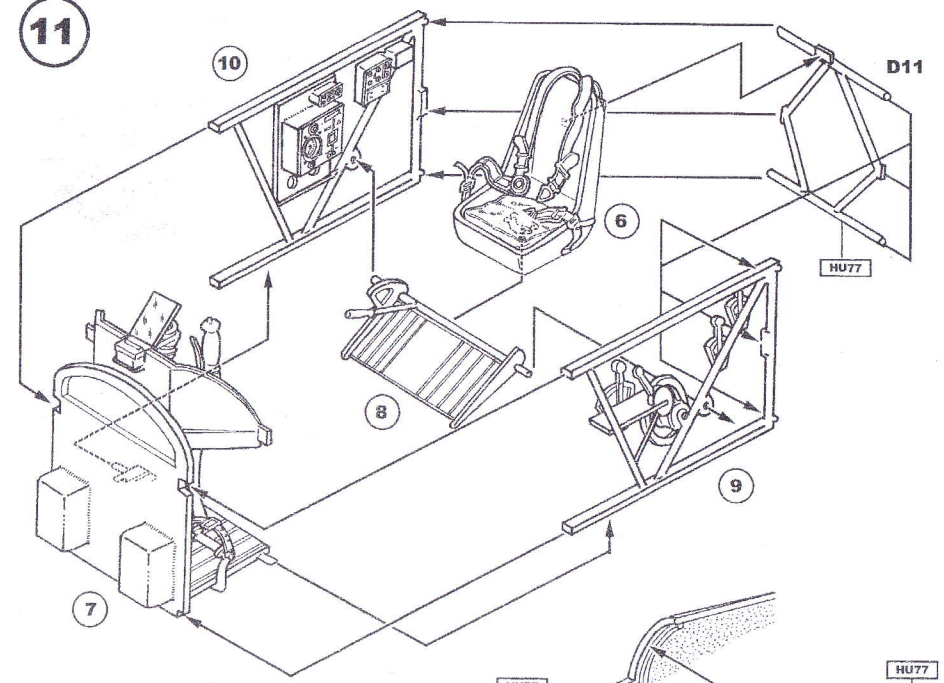

12

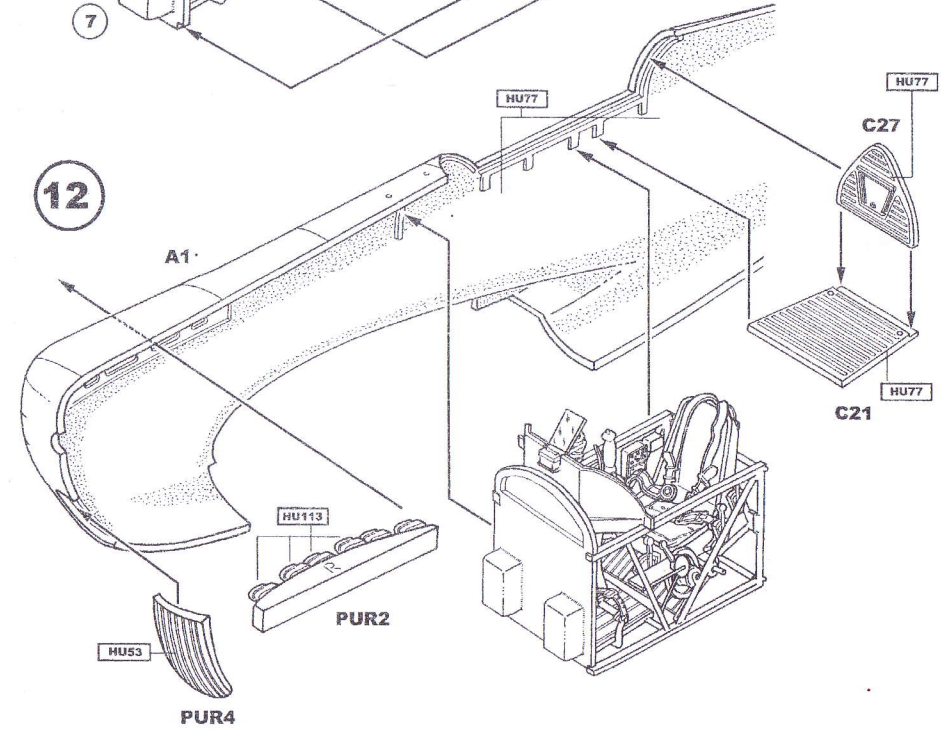

5



13

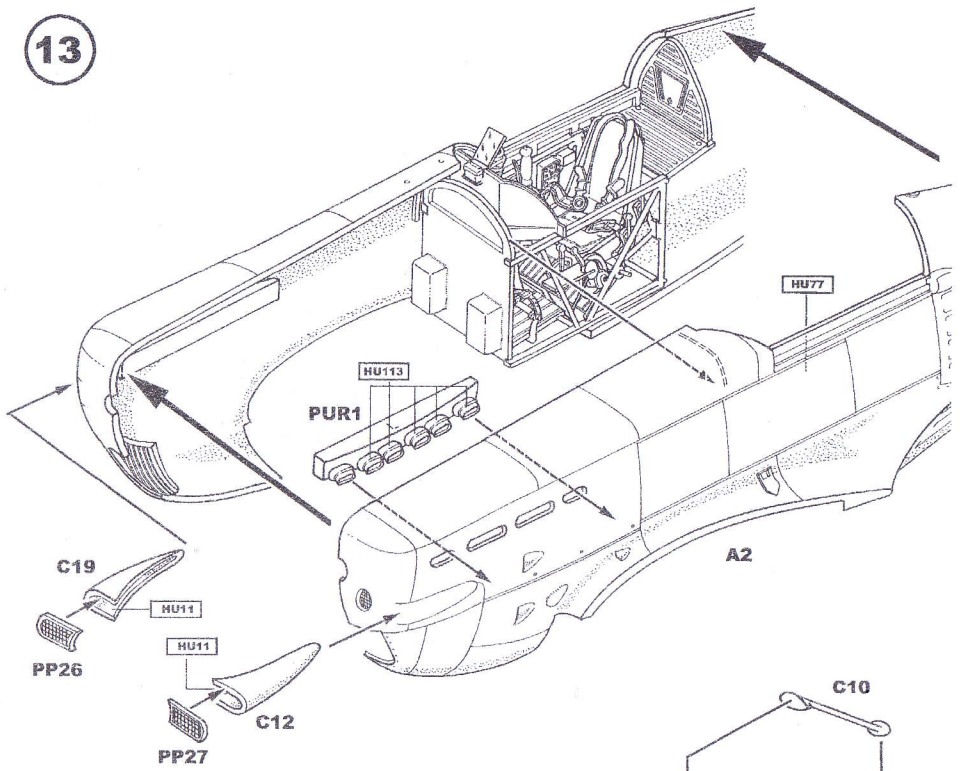

14

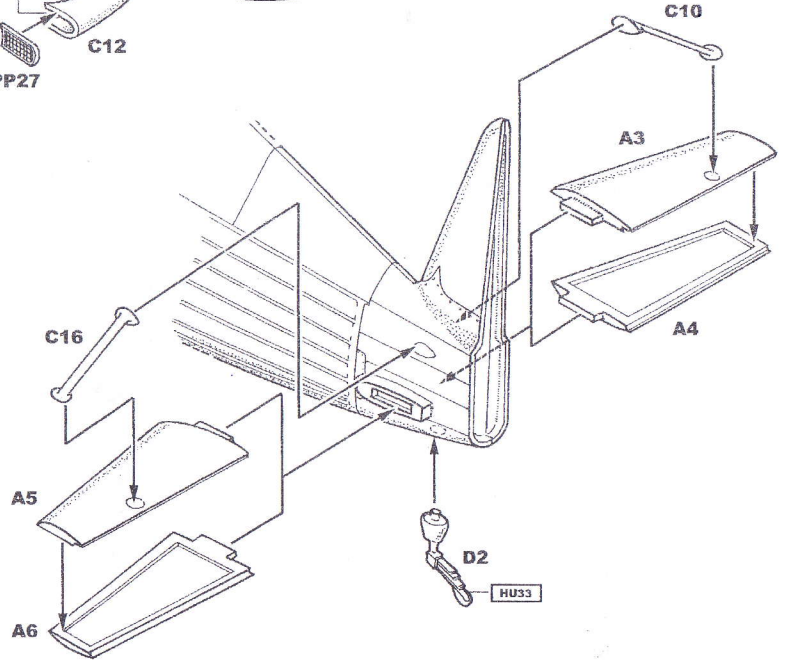

15

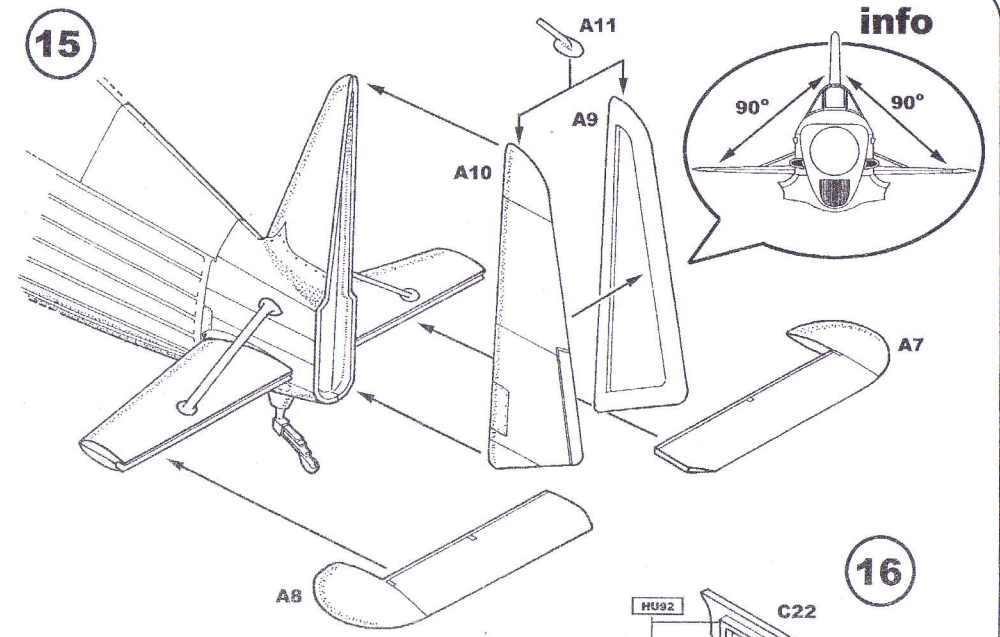

16

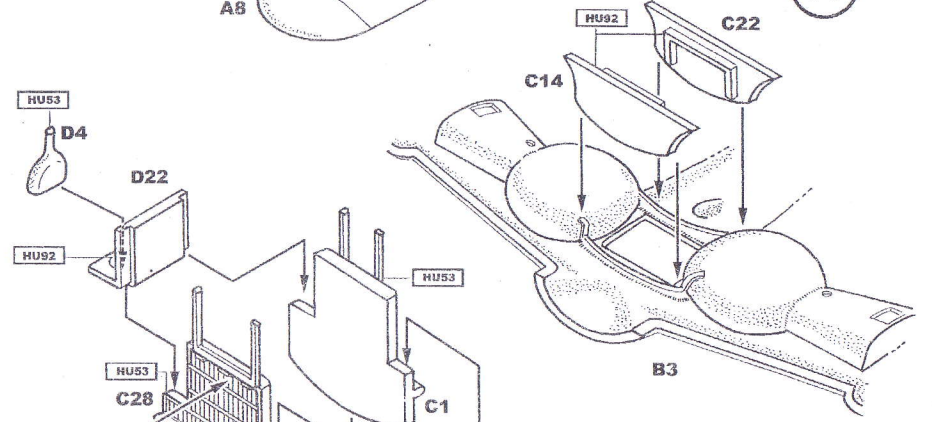

17

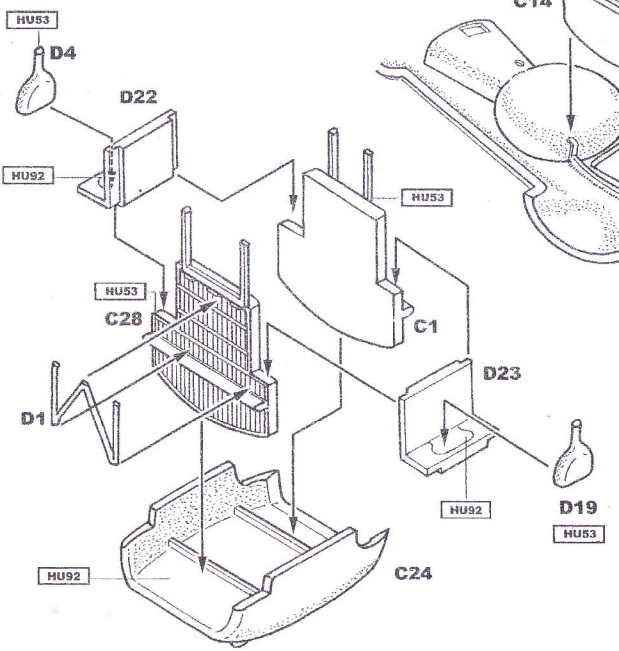



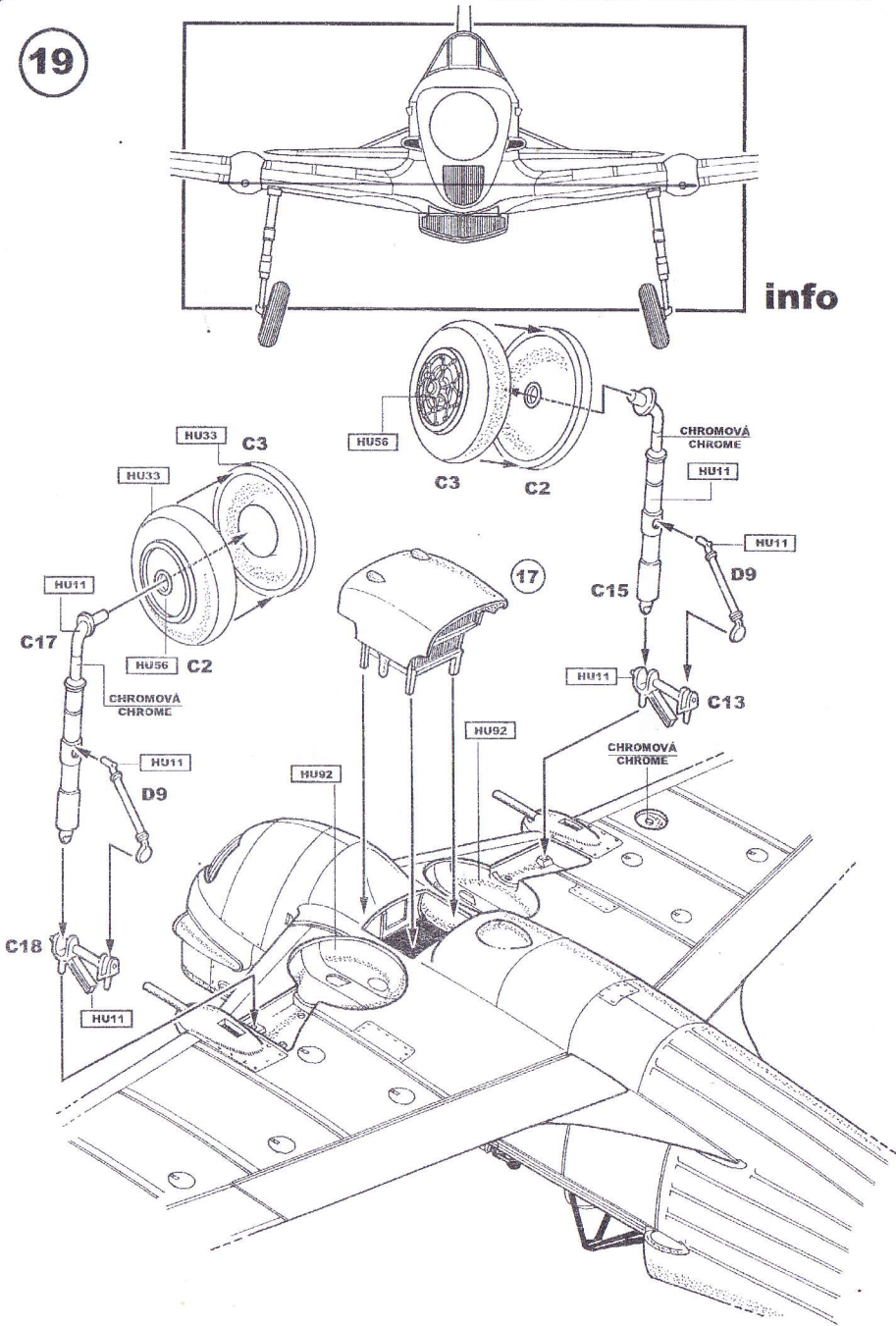
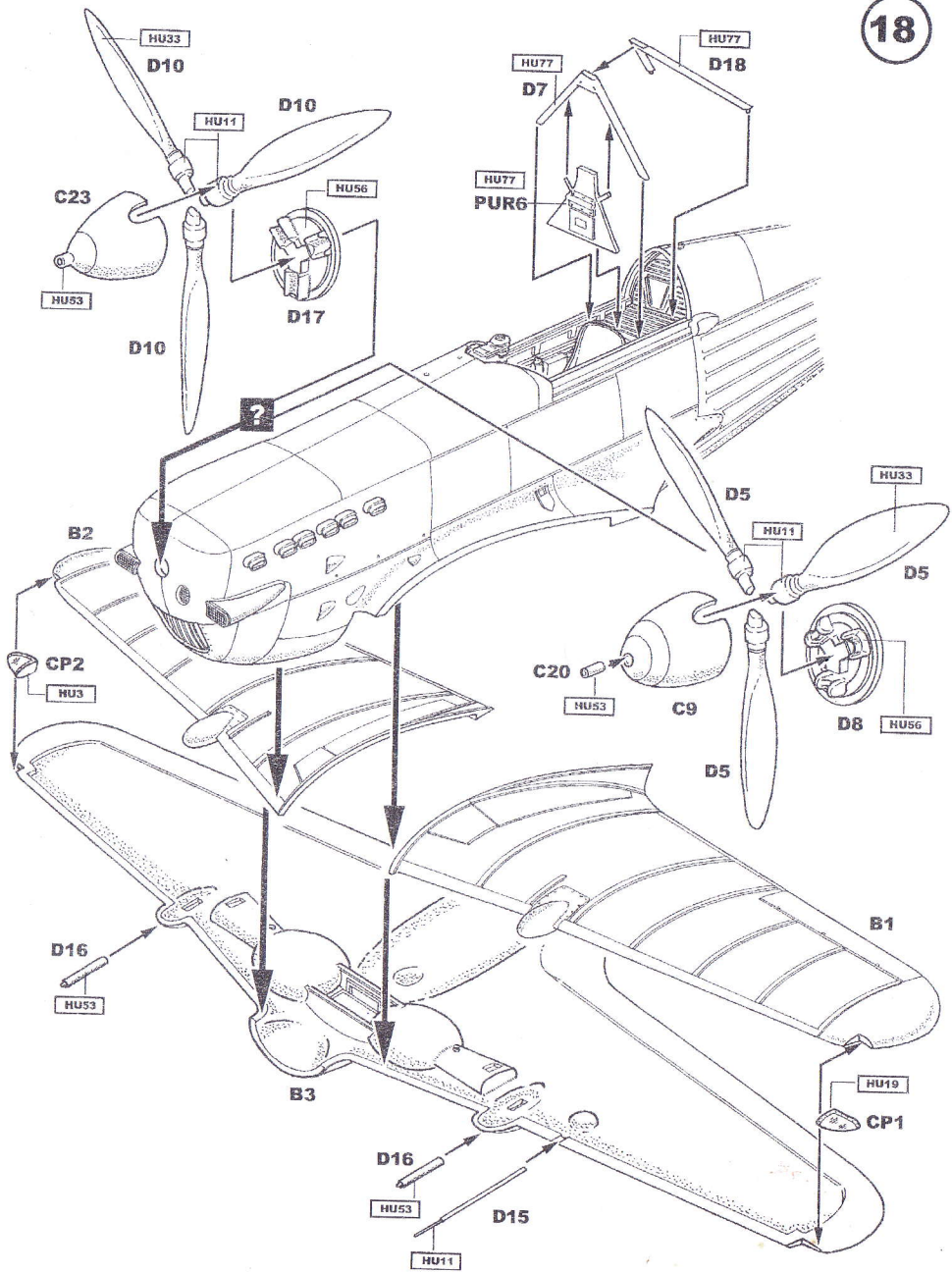

info



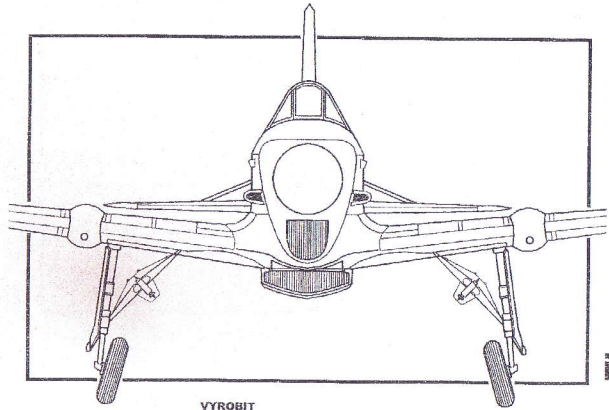

info

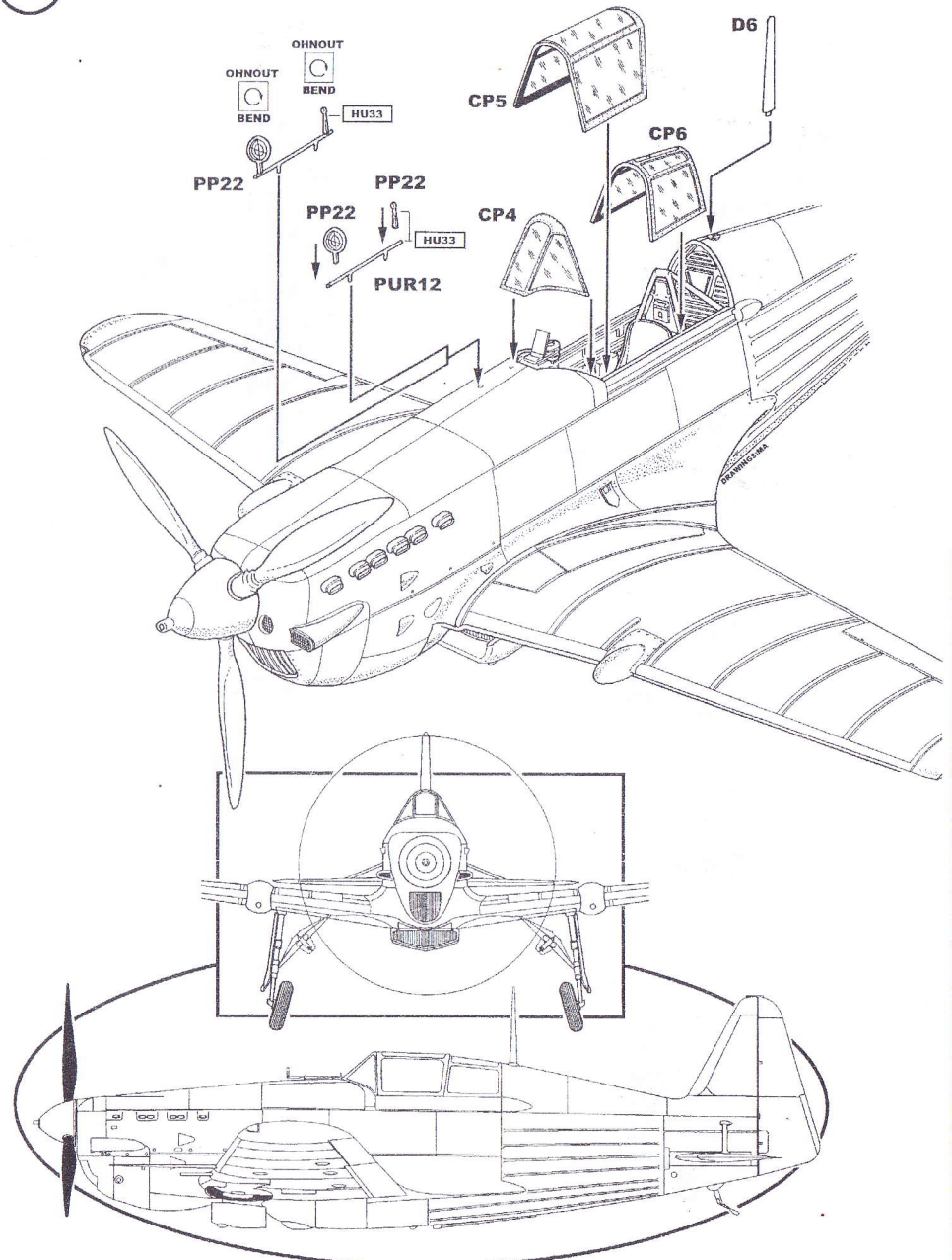
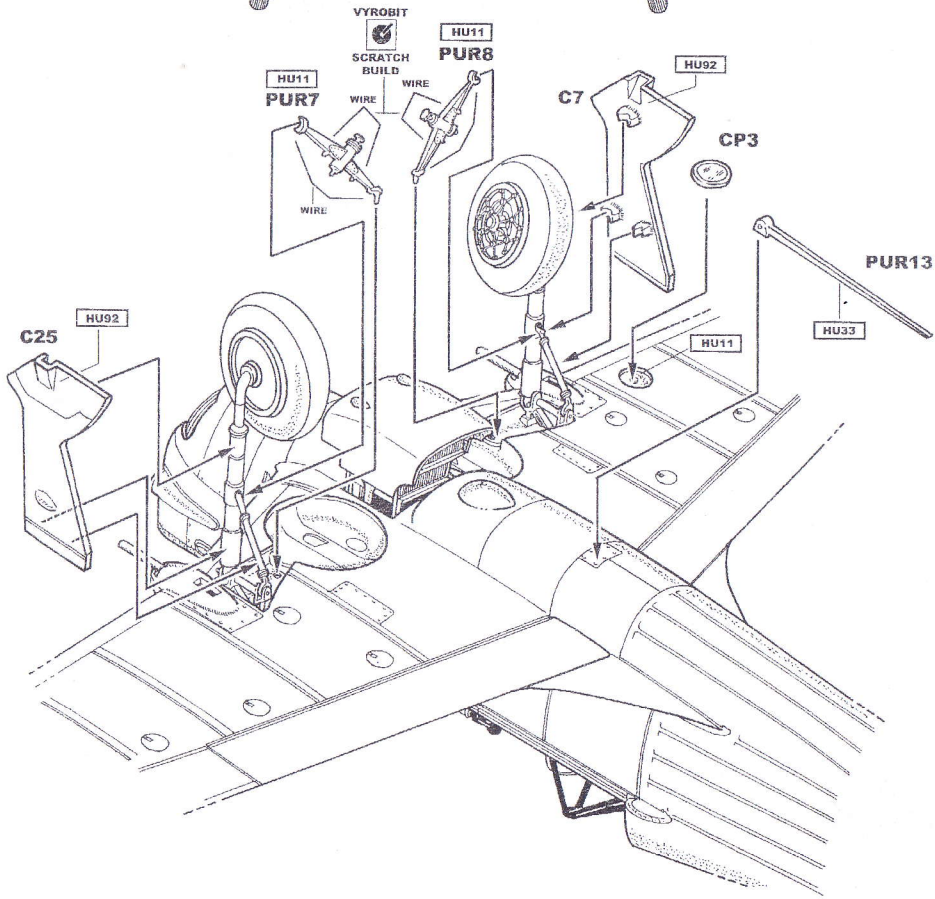

Moran-Saulnier M.S.406, 1. eskadra G/C I/2, červen 1940  
Moran-Saulnier M.S.406, 1th Escadrille G/C I/2, Jun 1940

