

# 5. DECAL PLACEMENT

NOTE: See box illustration for remaining trailer decals.

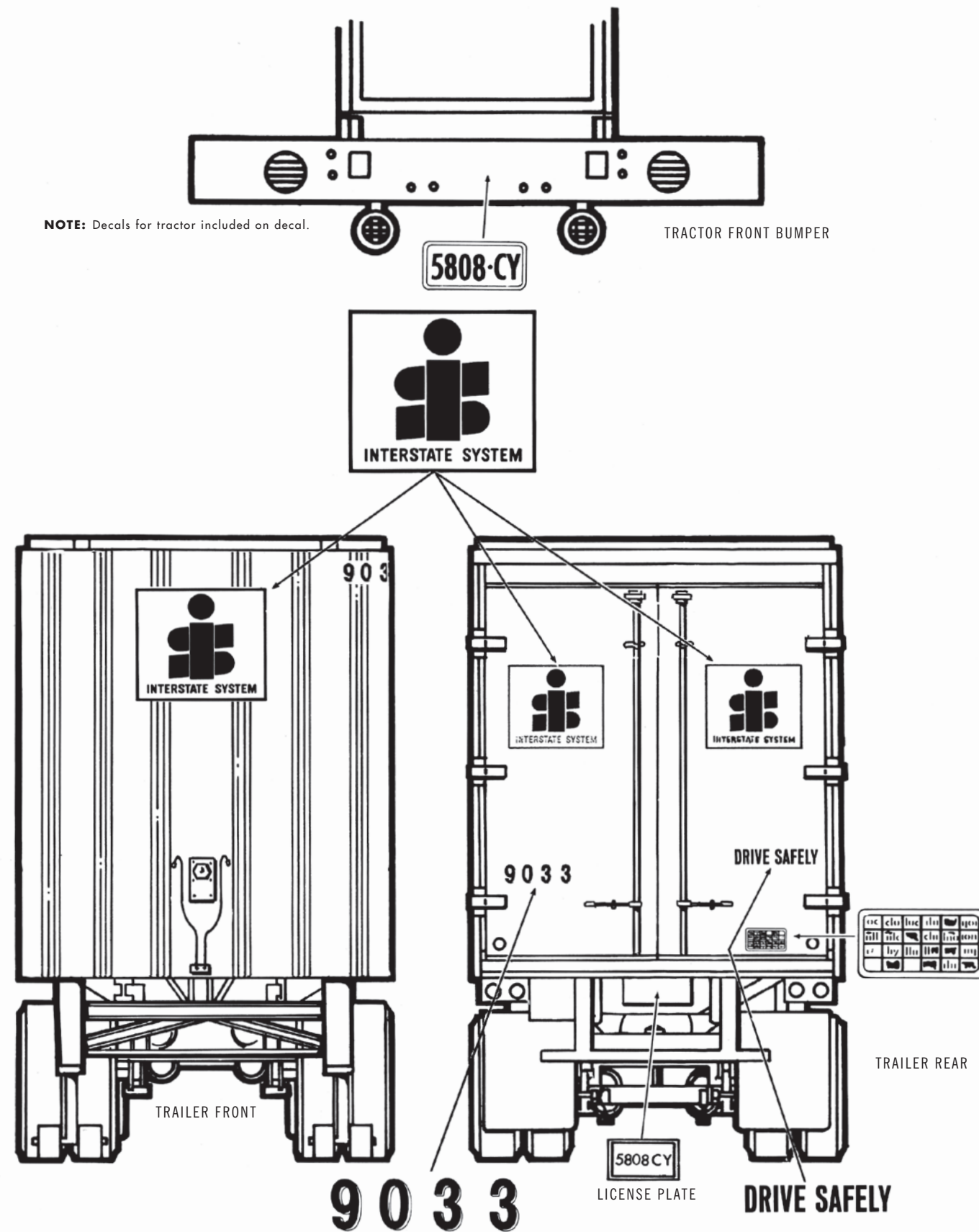

## CREATING BACKING PANELS FOR THE LOGO DECALS

Your AMT Fruehauf Exterior Post Trailer kit includes a 4.0" x 6.0" sheet of thin plastic. As an option, you may create backing panels for any of the large logo decals you plan to apply to the sides of the van.

1. Start by carefully cutting out the decals you wish to use from the decal sheet. Cut very close to the color.
2. One by one, lay each decal over the plastic sheet and trace around it, adding an additional 1/32" frame all the way around.
3. Cut the shapes out of the plastic with scissors. USE CAUTION.
4. Apply the decals to the plastic backing panels and glue the panels to the sides of the Van.

Goodyear (and wing foot design) and Eagle are trademarks of The Goodyear Tire & Rubber Company, Akron, Ohio USA used under license by Round 2, LLC. Other names and trademarks used under license to Round 2, LLC or by permission. AMT & design is a registered trademark of Learning Curve Brands, Inc. used under license to Round 2, LLC. ©2011 Learning Curve Brands, Inc. All rights reserved. ©2011 Round 2, LLC, South Bend, IN 46628 USA. Product and packaging designed in the USA. Made in China. All rights reserved.



# 40 Foot **FRUEHAUF** EXTERIOR POST VAN

## READ THIS BEFORE YOU BEGIN

Look over this instruction sheet carefully before you begin building. Follow the assembly instructions and "test-fit" the parts without cementing. This will familiarize you with the location of the parts.

For the best results, the various sub-assemblies and components should be painted before any "chrome" parts are attached. For example: When attaching "non-chrome" body accessories, it is best to cement them in place and paint the body as a unit.

AMT kits are molded from the finest High-Impact Styrene plastic. Use only

paint and cement made for Styrene. Trim excess plastic from parts before joining. Use just enough cement to join parts, and be careful not to smear cement on exposed surfaces.

Built according to the instructions on this sheet, you should have no trouble assembling your model. Just FOLLOW THE NUMBERS. The parts are numbered in the order of assembly. (C) INDICATES "CHROME" PARTS.

Cement all parts unless otherwise indicated.

## 1. WHEELS

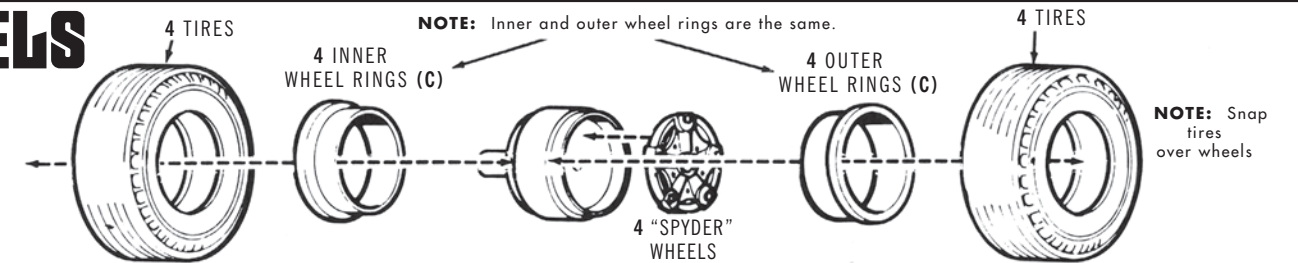

## 2. SUSPENSION ASSEMBLIES

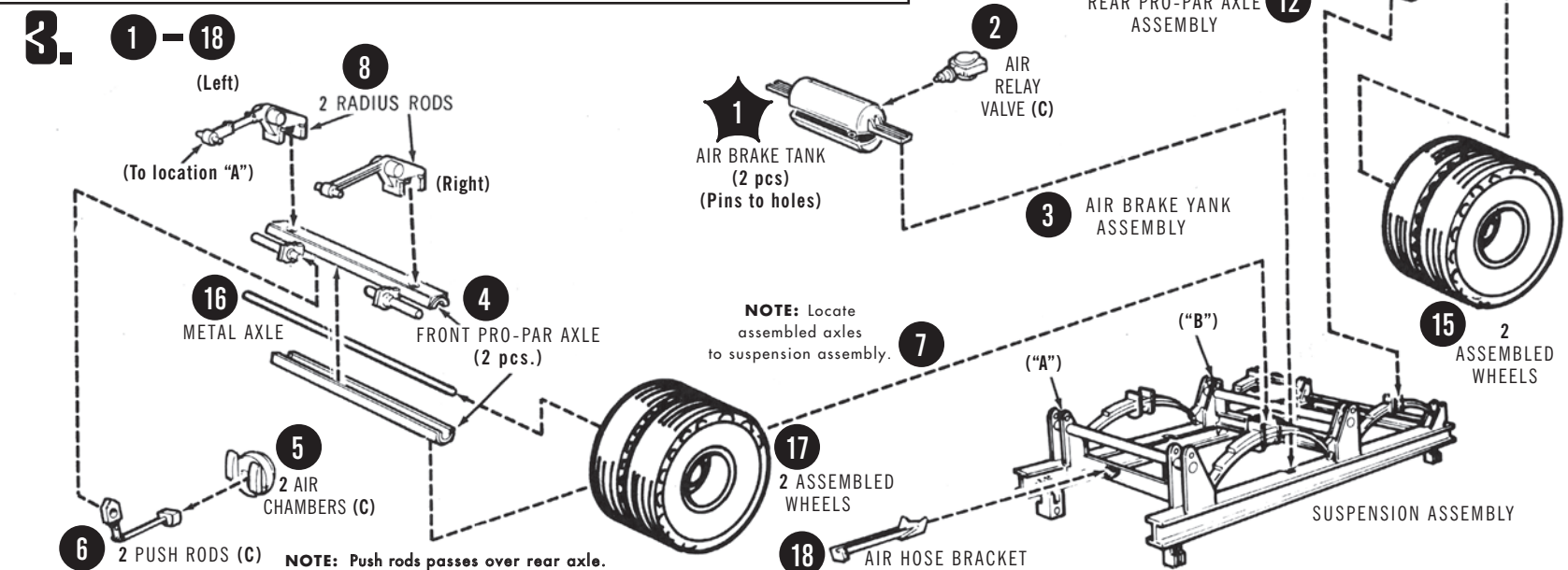
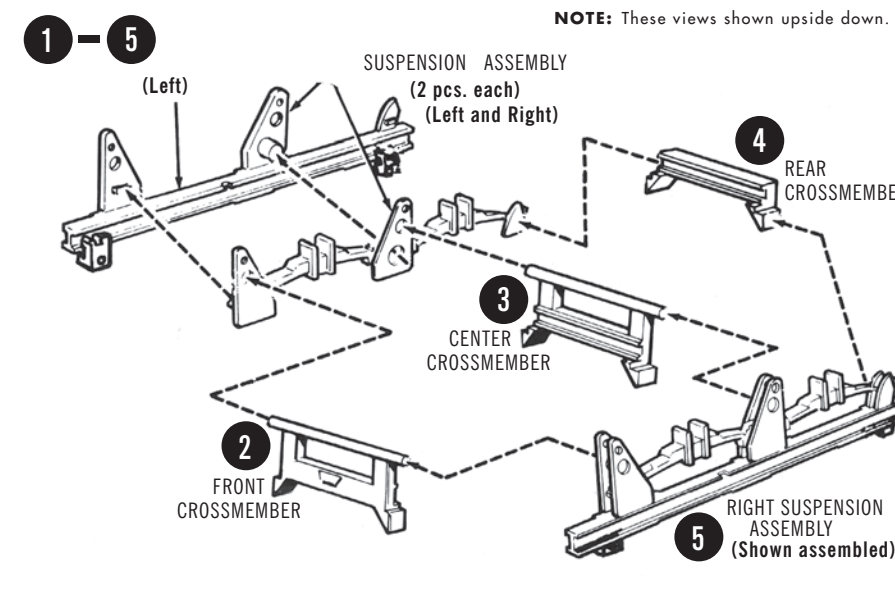

Goodyear (and wing foot design) and Eagle are trademarks of The Goodyear Tire & Rubber Company, Akron, Ohio USA used under license by Round 2, LLC. Other names and trademarks used under license to Round 2, LLC or by permission. AMT & design is a registered trademark of Learning Curve Brands, Inc. used under license to Round 2, LLC. ©2011 Learning Curve Brands, Inc. All rights reserved. ©2011 Round 2, LLC, South Bend, IN 46628 USA. Product and packaging designed in the USA. Made in China. All rights reserved.

# 4. FINAL ASSEMBLIES 1-28

NOTE: This view shown upside down.

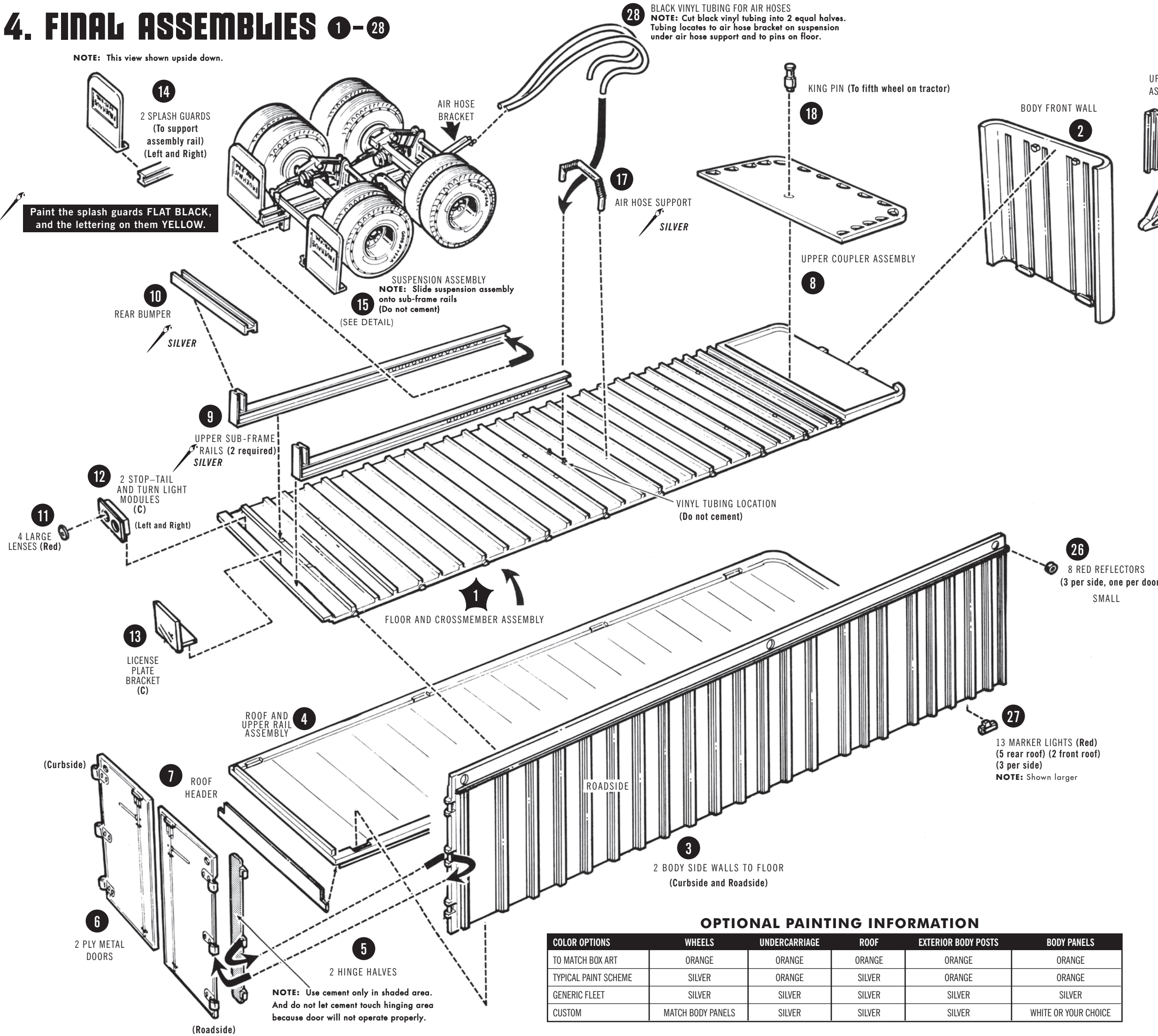

## OPTIONAL PAINTING INFORMATION

COLOR OPTIONS	WHEELS	UNDERCARRIAGE	ROOF	EXTERIOR BODY POSTS	BODY PANELS
TO MATCH BOX ART	ORANGE	ORANGE	ORANGE	ORANGE	ORANGE
TYPICAL PAINT SCHEME	SILVER	ORANGE	SILVER	ORANGE	ORANGE
GENERIC FLEET	SILVER	SILVER	SILVER	SILVER	SILVER
CUSTOM	MATCH BODY PANELS	SILVER	SILVER	SILVER	WHITE OR YOUR CHOICE

