

Spitfire Mk.Vb late

eduard

1/48 Scale Plastic Model Kit

ProfiPACK
edition



item No. 82156

The Supermarine Spitfire is so iconic, that virtually everyone can recognize it. The service of this elegant fighter spanned remarkable 13 years. It entered the service at the end of biplane era and remained on frontline duty until the dawn of jet age.

By the early 30s the RAF was looking for replacement of its ageing Hawker Fury biplane fighters. The need of considerably faster aircraft was obvious, as the racing monoplane floatplanes of that time were reaching about twice the speed of the Fury. One of the most successful designers of the racing floatplanes was Reginald J. Mitchell. His Supermarine S.6B raised the world speed record to 407 mph (655 km/h) on September 20, 1931, and British Air Ministry, under influence of such achievement, issued the specification F.7/30 in October 1931. Although it called for modern pursuit aircraft capable of at least 250 mph (400 km/h), seven out of eight entries were biplane designs. The only monoplane proposal was Mitchell's Supermarine 224, but the aircraft with a gull wing, fixed undercarriage and Rolls-Royce Goshawk engine was a disappointment as it lacked speed and rate of climb. Due to that, the Gloster Gladiator biplane was declared a winner.

Early work

The fiasco with Type 224 did not prevent Mitchell from further work. He persuaded the Supermarine company to fund the work on the completely new design Type 300 using the brand new Rolls-Royce PV12 engine, later known as the Merlin. The Air Ministry expressed interest and issued specification F.37/34 on December 28, 1934 to fund a prototype armed with four wing mounted guns. By early April 1935 Mitchell received the detail of specification F10/35, and it was calling for eight guns. The change was made on cost of bomb provision removal and reduction of the fuel tanks volume to sixty-six gallons. The decision caused the so called "short legs" of the Spitfire, meaning a lack of range. The Supermarine Type 300 made its maiden flight on March 5, 1936, an initial contract to produce 310 Spitfires was signed in June 1936 and the first unit to receive the new fighter was No. 19 Squadron at Duxford in August 1938.

Searching for performance

The Spitfire's development was an ongoing process from very early stage of its service and incorporated many changes. From the early Mk.I and Mk.II the development reached the point, where a more substantial performance step was required. After trials with the Merlin XX engine, installed in the prototype of the Spitfire Mk.III, Rolls-Royce offered a viable and quick solution in late 1940, the concurrently developed and simpler to manufacture Merlin RM5S engine (later designated Merlin 45). It featured one-stage single-speed compressor optimized for high altitudes. Its output at 17,700 ft (5,400 m) was 1,210 hp (902 kW). The Merlin 45 was the same size as the Merlin III powering the Mk.I Spitfires, and its design allowed the Merlin III to be upgraded to the Merlin 45 by changing the supercharger. This facilitated the simple installation into the freshly built Spitfire Mk.I and Mk.II airframes and the conversion of the existing aircraft as well.

First two converted Spitfires were test-flown at Boscombe Down, where a maximum speed of 593 kph at 20,000 ft (6,100 m) was recorded during the flight tests. The trials also brought out the problems with the De Havilland constant-speed propeller as oil of its control system was freezing at high altitudes. There were troubles with Mk.II oil cooler as well as it was not efficient enough for the more powerful engine. Even though this was considered an interim solution, as the Spitfire Mk.III production was still being planned, the order for new Spitfires was placed, or, better said, the program for converting Spitfires Mk.I and Mk.II into Spitfires Mk.V was ordered.

The CBAF (Castle Bromwich Aircraft Factory) launched the Spitfire Mk.V production in June 1941 while it was fulfilling the contract for 1,000 Mk.IIs, signed on April 12, 1939. Gradually the company received another eight orders to produce Spitfires Mk.V, of which the last one, from May 1942, largely transitioned to the manufacture of modernized Spitfires Mk.IX. Until the end of April 1943, the total production at CBAF reached 3,003 Spitfires Mk.Vb and 1,474 Spitfires Mk.Vc.

Since the summer 1943, the Mk.V production was under way at Westland company located in Yeovil in county of Somerset. Westland manufactured various versions of Spitfire Mk.V until November 1943 and ultimately delivered a total of 140 Mk.Vb and 495 Mk.Vc. Finally, 6464 Spitfires Mk.V of all variants were manufactured.

This kit: Spitfire Mk.Vb

In the middle of March 1941, Spitfire X4922 built in Eastleigh at Spitfire Mk.I assembly line, arrived at Boscombe Down. It already featured Merlin 45 and was test-flown on February 7. During the trials this prototype was fully armed and equipped and reached the maximum speed of 374,7 mph (603 kph). In Eastleigh, in the second half of February, a total of 23 Spitfire Mk.I airframes, mostly version Mk.Ib, received Merlin 45, thus becoming the first Spitfires Mk.Vb armed with four .303 machine guns and two 20mm cannons. This mark was the most produced, while there were only 94 of eight wing .303 machine guns Spitfires Mk.Ia produced. The Mk.Vc had usually the same armament as the Mk.Vb although with possibility to be armed with four 20mm cannons. Besides the engine, the equipment of these aircraft corresponded to Spitfire Mk.I standard including the smaller oil cooler with U-shaped intake which was the cause of higher oil temperature of the first Spitfires Mk.V and posed a certain risk of engine overheating. During the two and half years of Spitfires Mk.V production, the airframe was gradually developed. Already at the beginning of manufacture they featured thicker armor in comparison to Mk.I and Mk.II. The oil cooler was soon replaced with a larger one featuring a circular intake which was retroactively installed on the first batch of Spitfires Mk.V, converted from Mk.I and Mk.II, and became one of the features distinguishing Spitfires Mk.V.

ATTENTION



UPOZORNĚNÍ



ACHTUNG



ATTENTION



注意



Carefully read instruction sheet before assembling. When you use glue or paint, do not use near open flame and use in well ventilated room. Keep out of reach of small children. Children must not be allowed to suck any part, or pull vinyl bag over the head.



Před započítím stavby si pečlivě prostudujte stavební návod. Při používání barev a lepidel pracujte v dobře větrané místnosti. Lepidla ani barvy nepoužívejte v blízkosti otevřeného ohně. Model není určen malým dětem, mohlo by dojít k požití drobných dílů.

INSTRUCTION SIGNS * INSTR. SYMBOLS * INSTRUKTION SINNBILDEN * SYMBOLES * 記号の説明

OPTIONAL
VOLBABEND
OHNOUTSAND
BROUSITOPEN HOLE
VYVRTAT OTVORSYMETRICAL ASSEMBLY
SYMETRICKÁ MONTÁŽREMOVE
ODŘÍZNOUTREVERSE SIDE
OTOČITAPPLY EDUARD MASK
AND PAINT
POUŽÍT EDUARD MASK
NABARVIT

PARTS



DÍLY



TEILE



PIÈCES



部品

PLASTIC PARTS

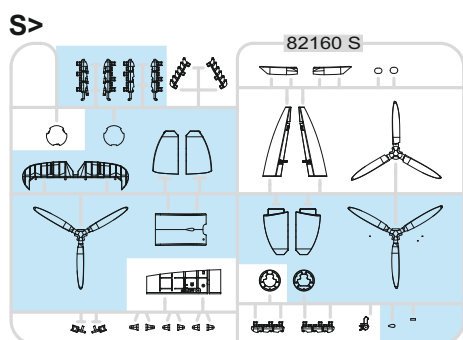
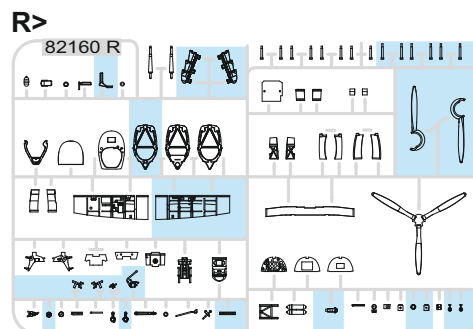
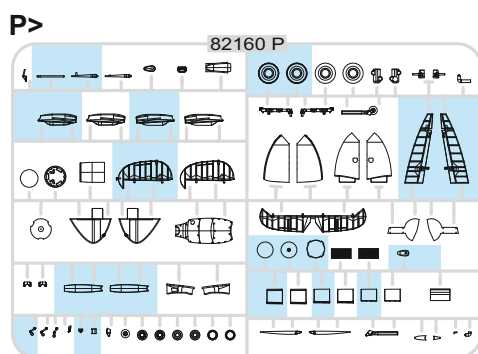
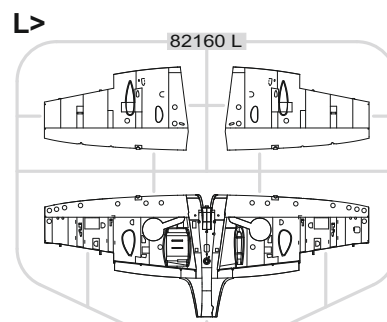
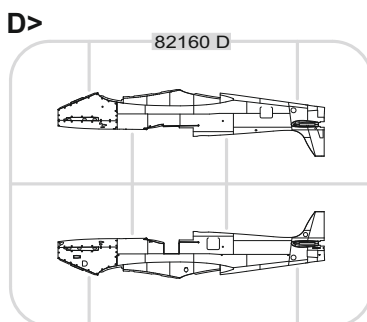
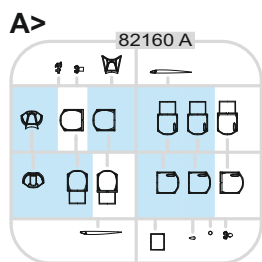

PE - PHOTO ETCHED DETAIL PARTS

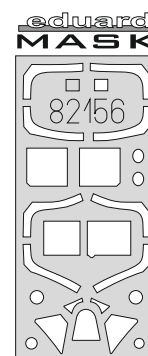
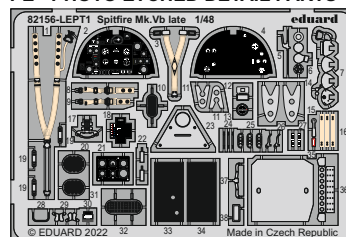

-Parts not for use. -Teile werden nicht verwendet. -Pièces à ne pas utiliser. -Tyto díly nepoužívejte při stavbě. - 使用しない部品

COLOURS



BARVY



FARBEN



PEINTURE



色

GSI Creos (GUNZE)		MISSION MODELS	
AQUEOUS	Mr.COLOR	PAINTS	
H2	C2	MMP-047	BLACK
H3	C3	MMP-003	RED
H4	C4	MMP-007	YELLOW
H8	C8		SILVER
H11	C62	MMP-001	FLAT WHITE
H12	C33	MMP-047	FLAT BLACK
H13	C3	MMP-003	FLAT RED
H32	C40		FIELD GRAY
H33	C81		RUSSET
H51	C11	MMP-063	LIGHT GULL GRAY
H74	C368	MMP-080	SKY
H77	C137	MMP-040	TIRE BLACK
H84	C42		MAHOGANY

GSI Creos (GUNZE)		MISSION MODELS	
AQUEOUS	Mr.COLOR	PAINTS	
H90	C47		CLEAR RED
H94	C138		CLEAR GREEN
H330	C361	MMP-077	DARK GREEN
H335	C363	MMP-094	MEDIUM SEAGRAY
	C362	MMP-093	OCEAN GRAY
	C364	MMP-079	AIRCRAFT GRAY-GREEN
H326	C326		BLUE
	C370	MMP-092	AZURE BLUE
Mr.METAL COLOR		METALLICS	
	MC214	MMM-001	DARK IRON
	MC218	MMM-003	ALUMINIUM
Mr.COLOR SUPER METALLIC		METALLICS	
	SM201	MMC-001	SUPER FINE SILVER

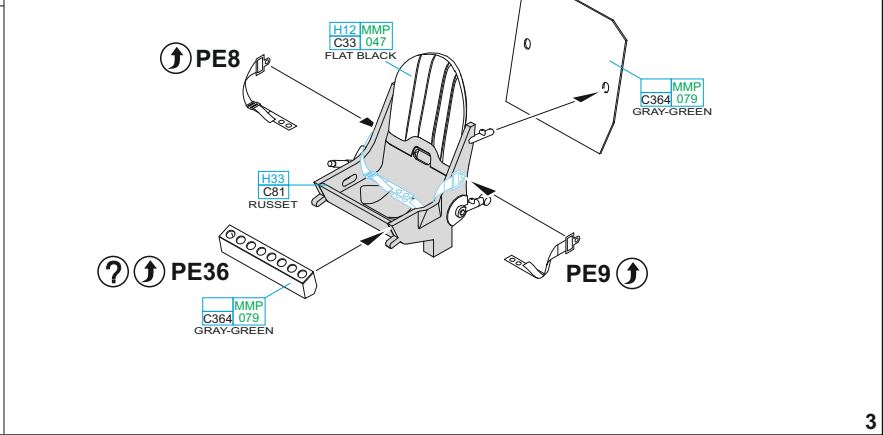
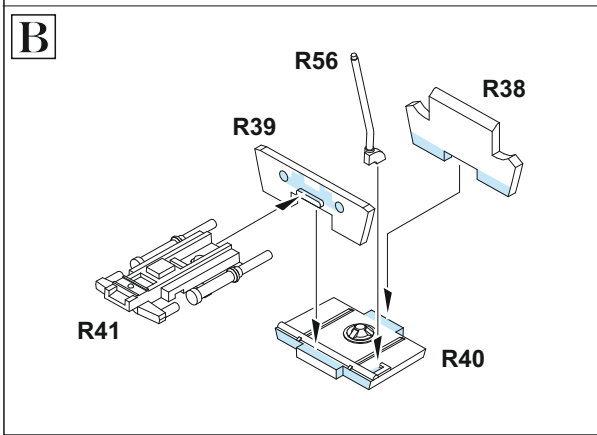
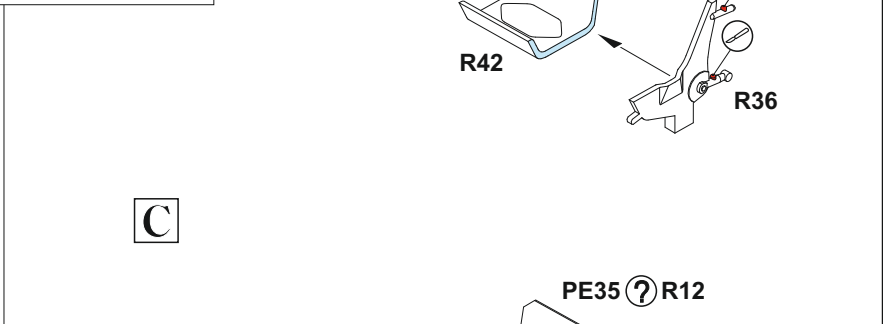
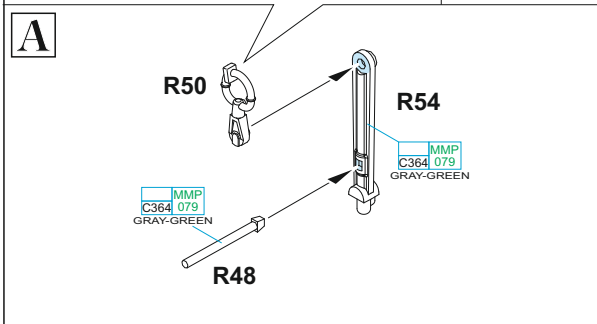
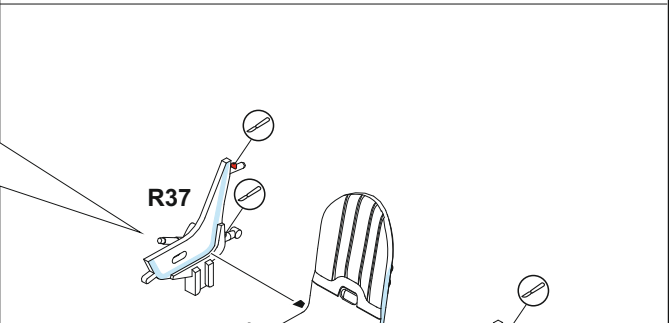
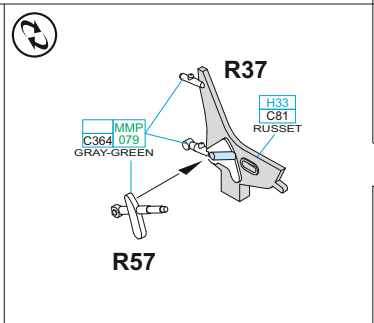
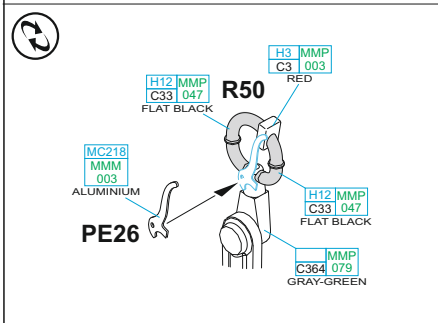
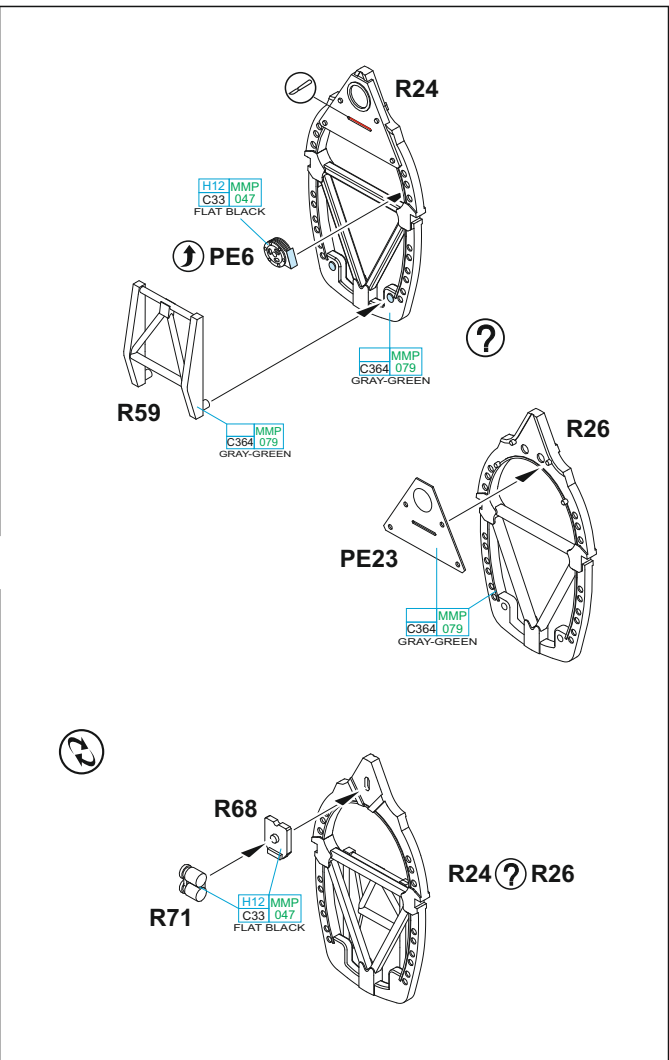
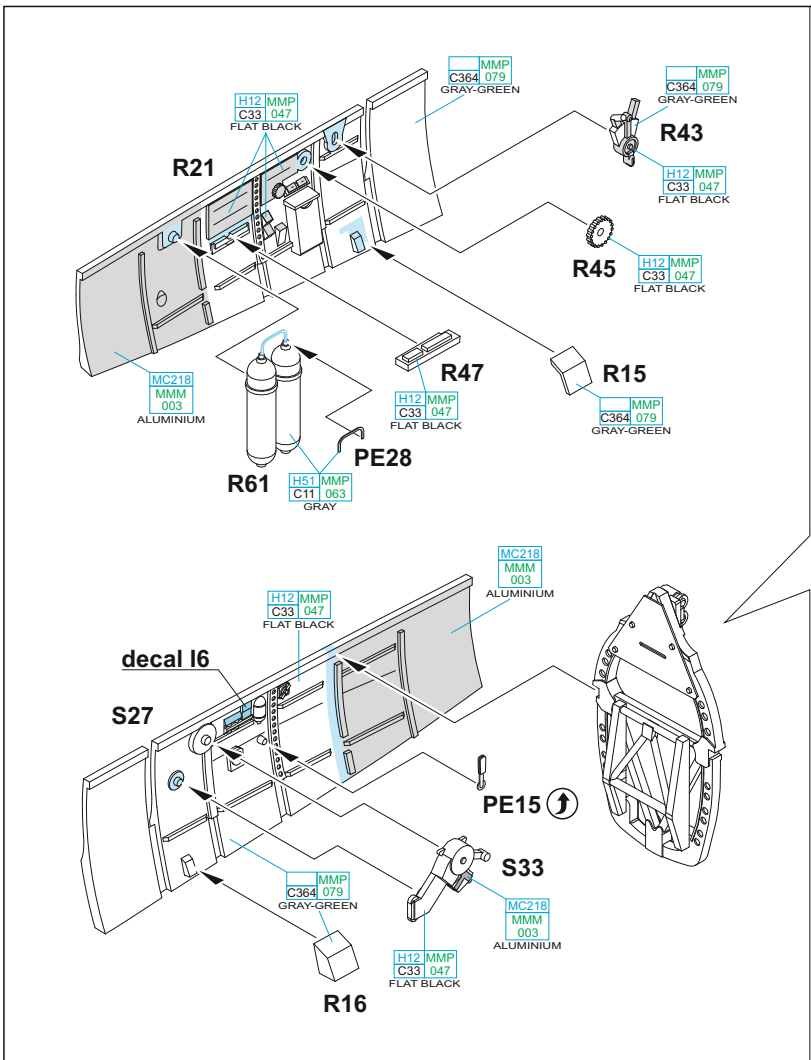

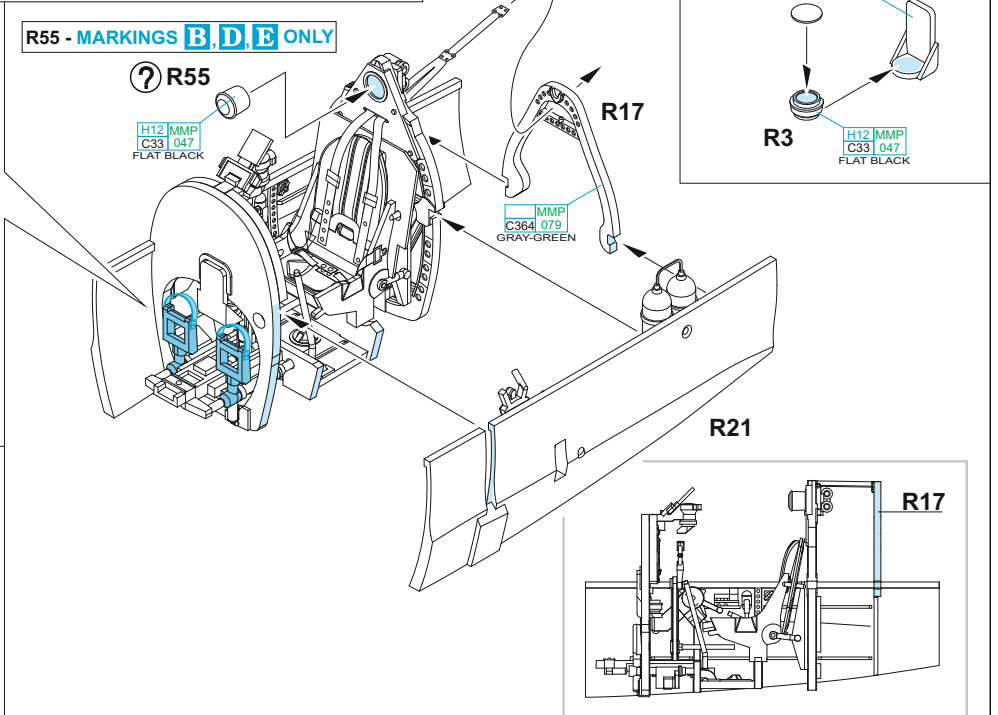
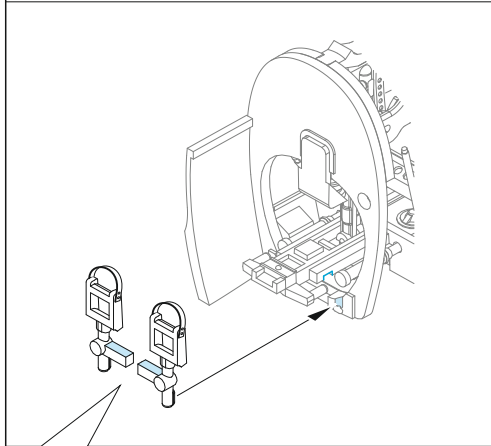
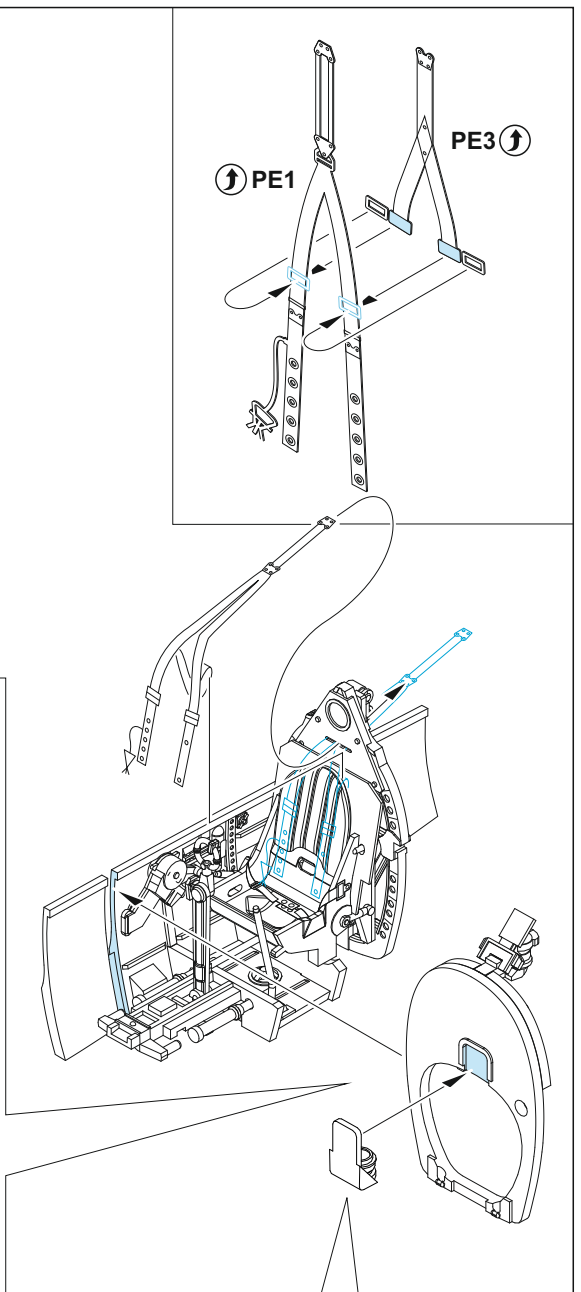
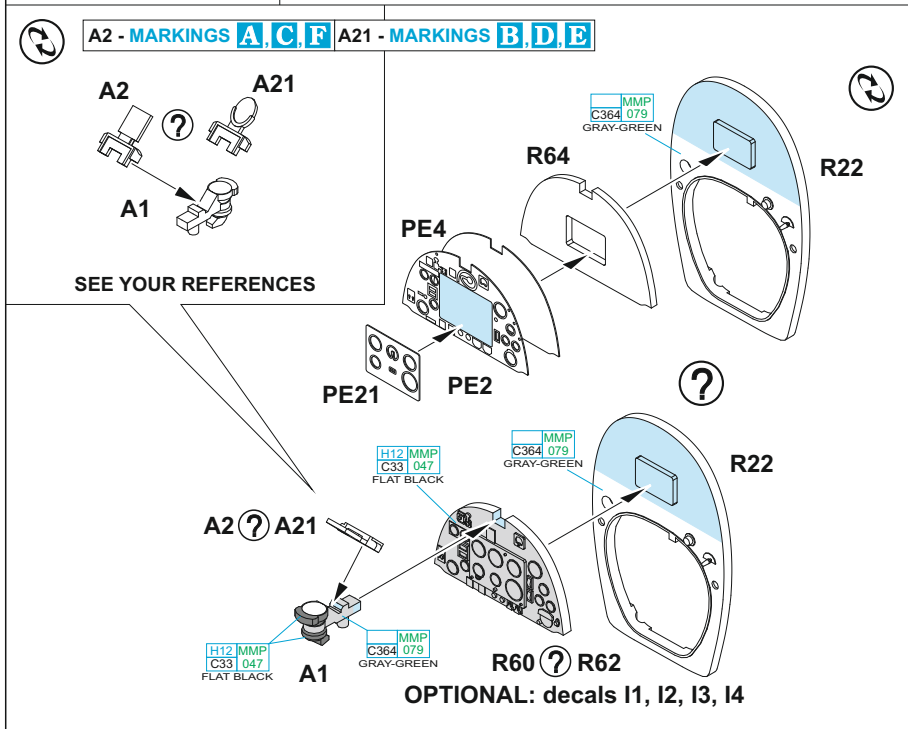
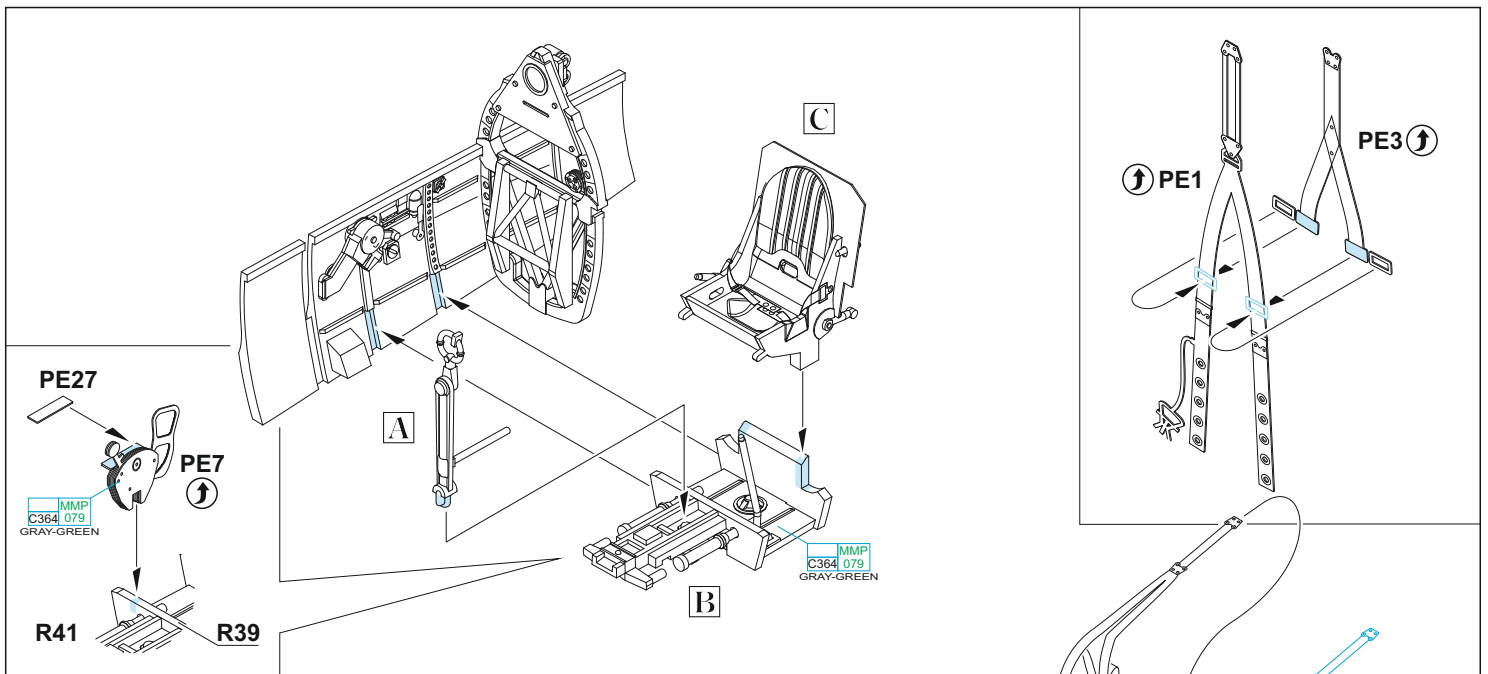

7 FOR CLOSED CANOPY ONLY

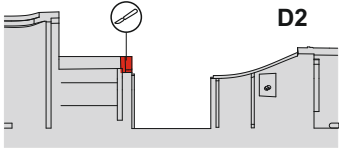

D2

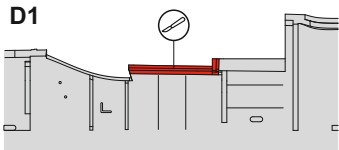

D1

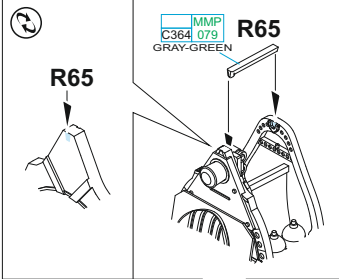

R65

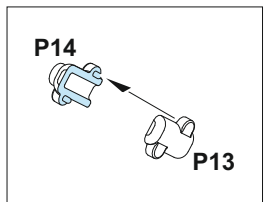

P14

P13

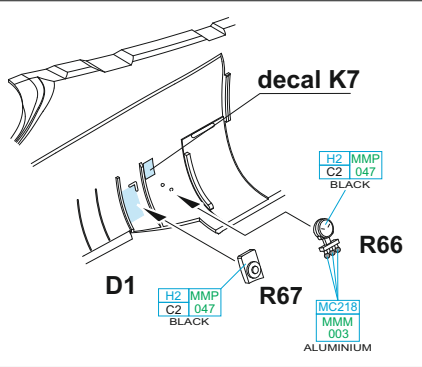
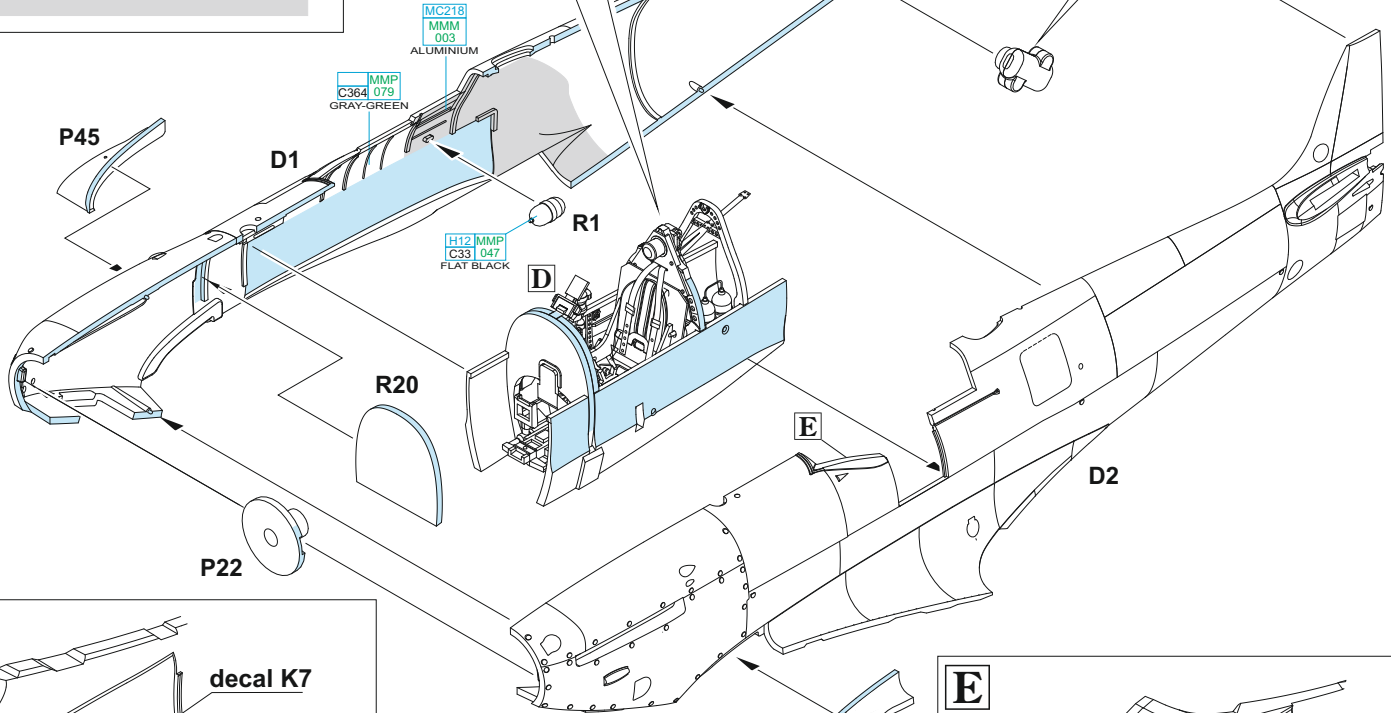

decal K7

R66

R67

D1

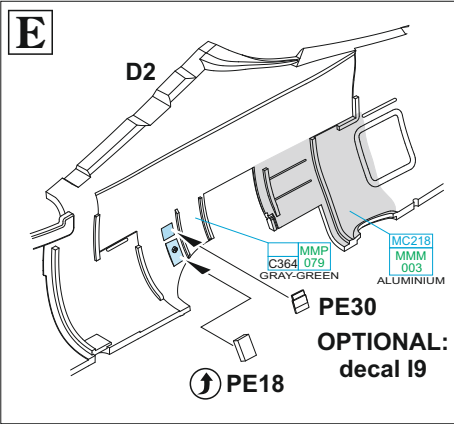

E

D2

PE30
OPTIONAL:
decal I9

PE18

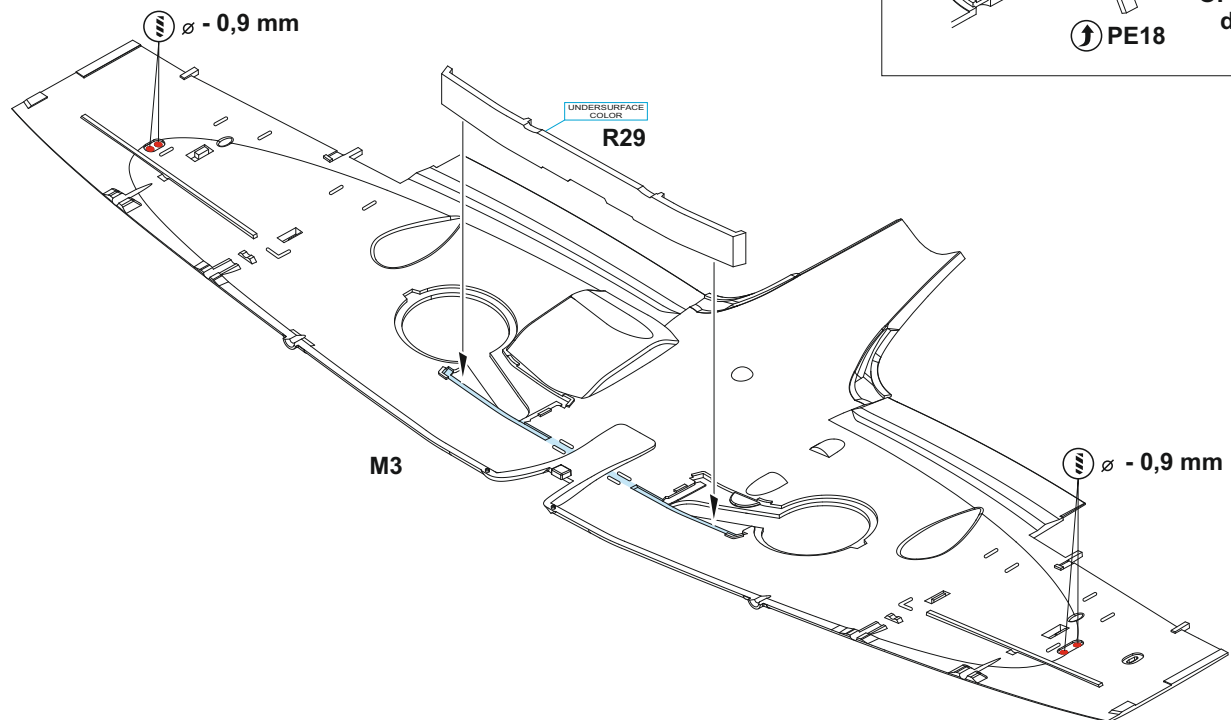

UNDERSURFACE
COLOR

R29

M3

$\varnothing - 0,9 \text{ mm}$

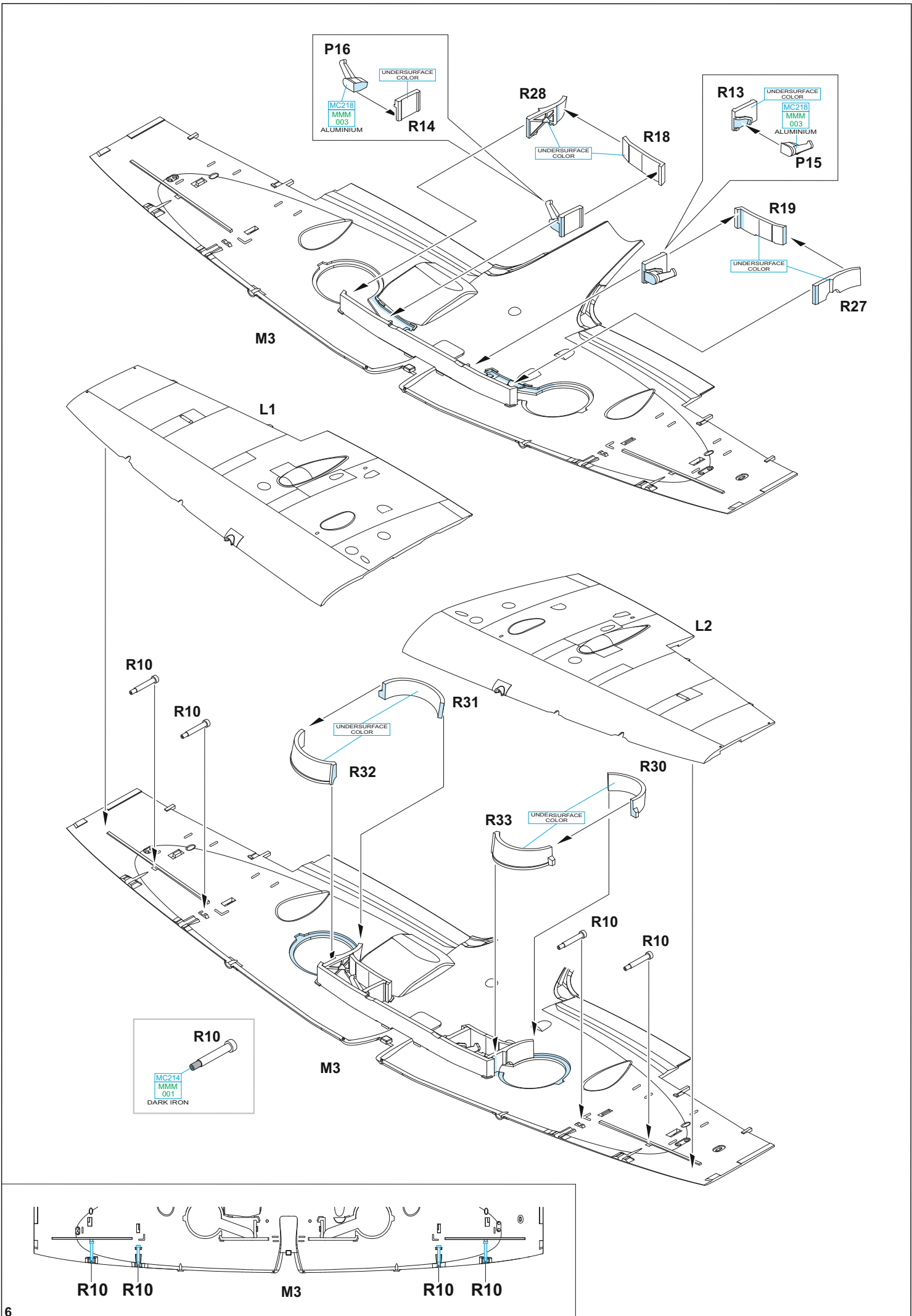

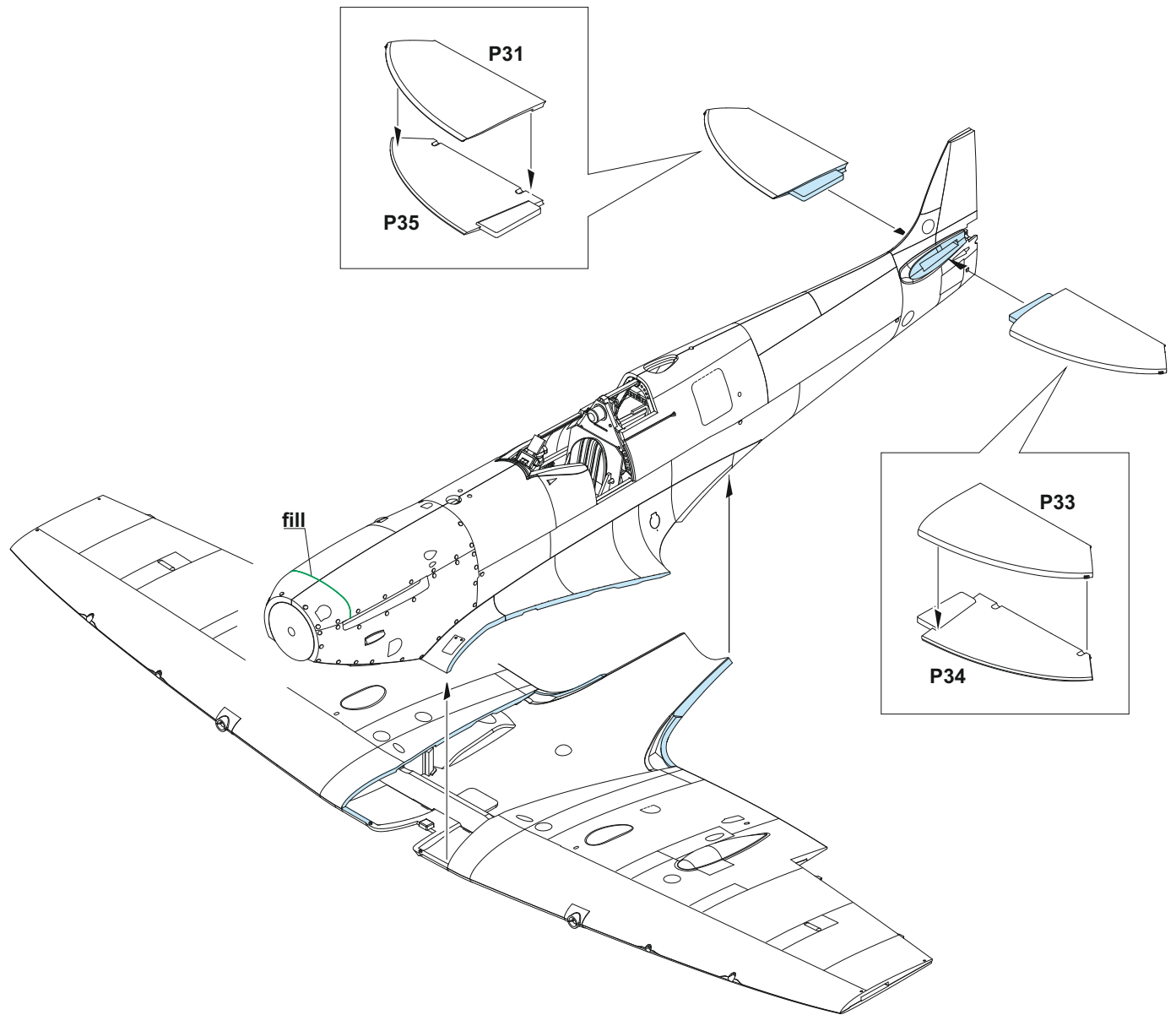

**GLUE PARTS P40 & P41
ONE BY ONE**

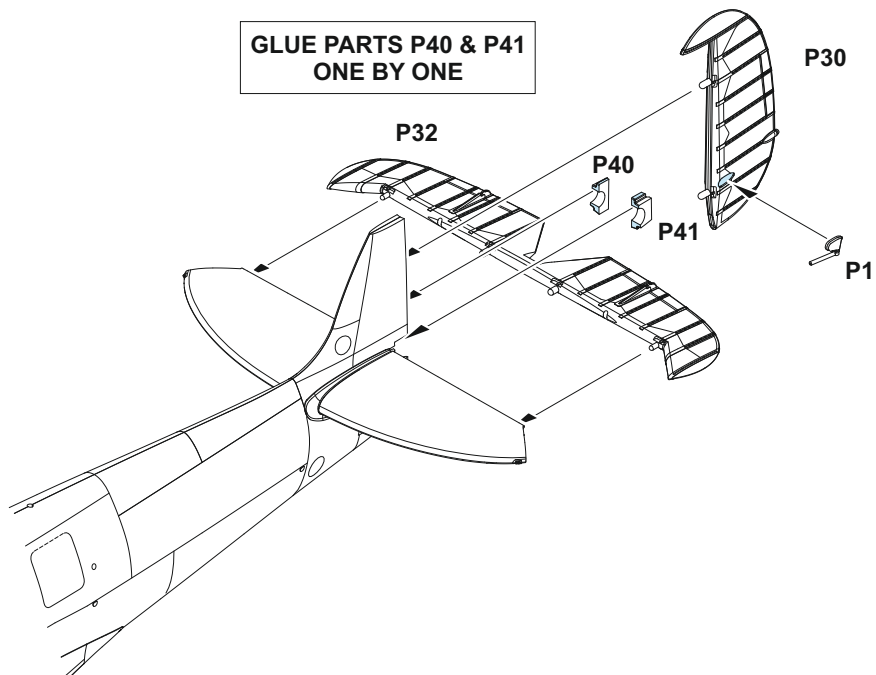

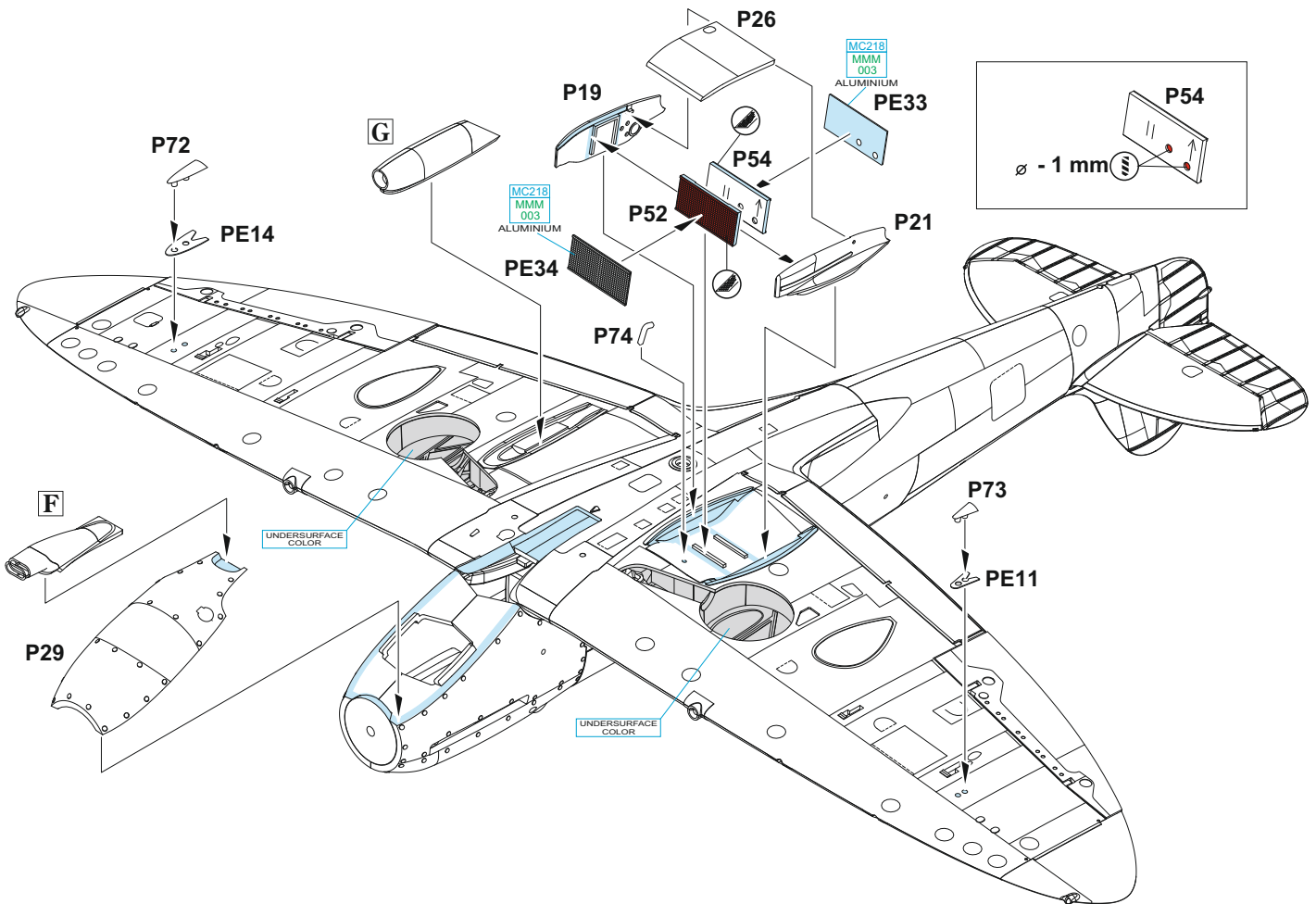
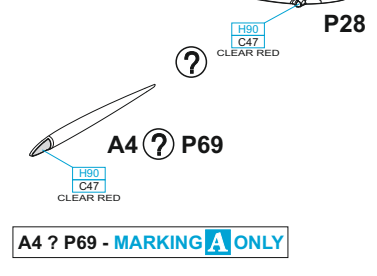
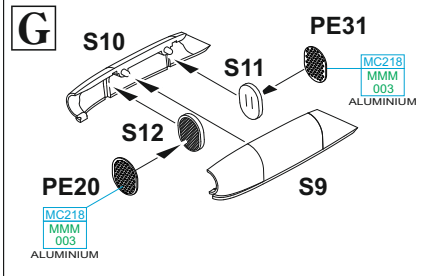
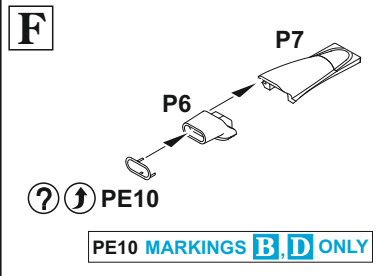
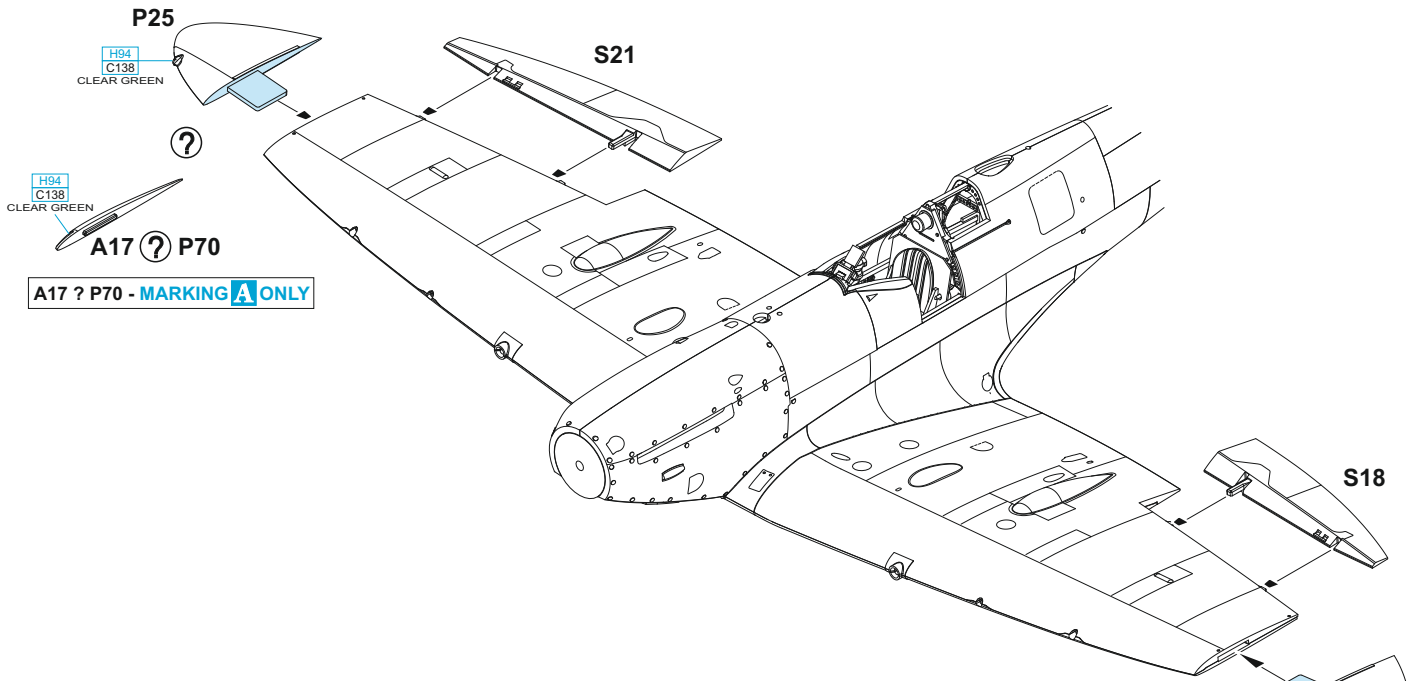

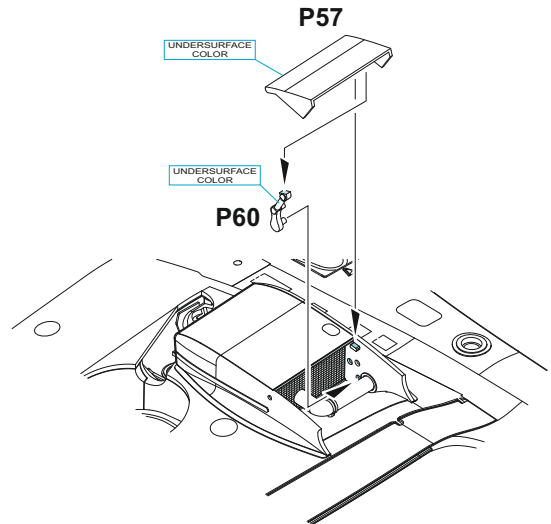
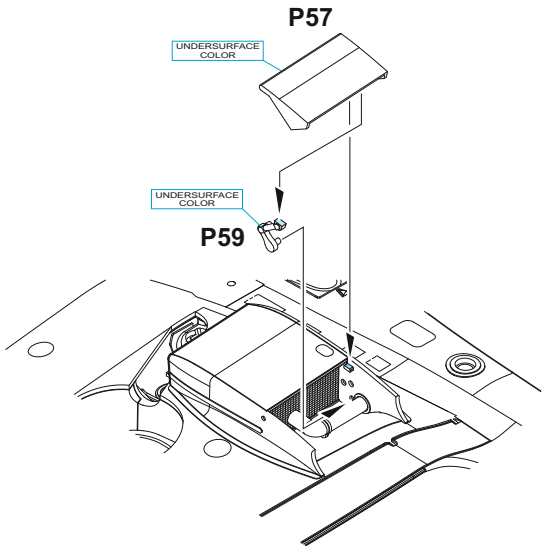
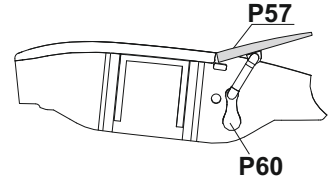
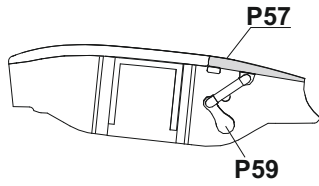
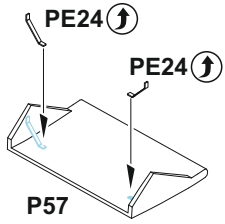
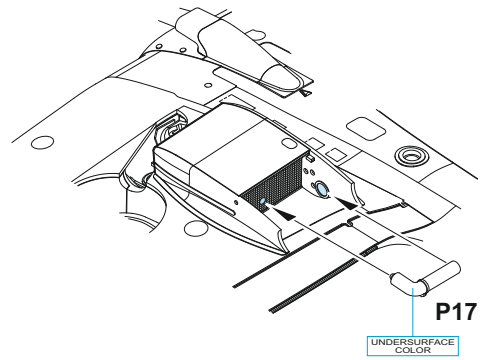
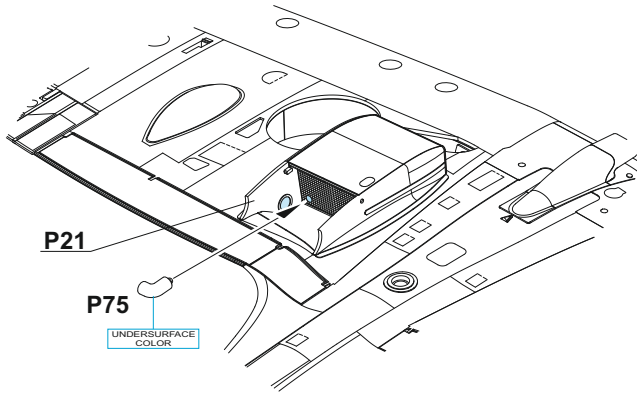

P66 - MARKINGS **A, B, C, D, E**

P67 - MARKING **F**

P66 ? P67

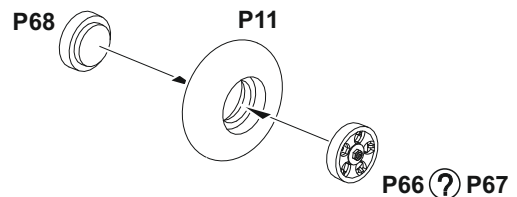
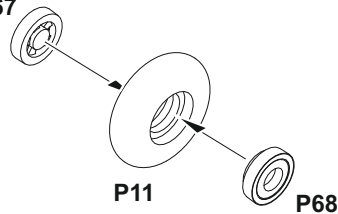

P66 - MARKINGS **A, B, C, D, E**

P67 - MARKING **F**

H

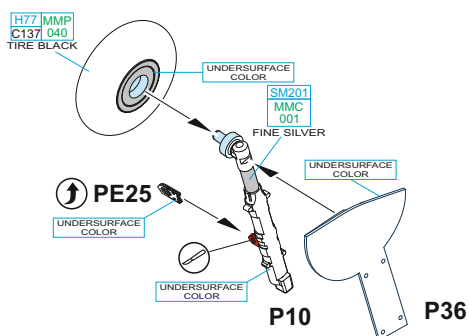

I

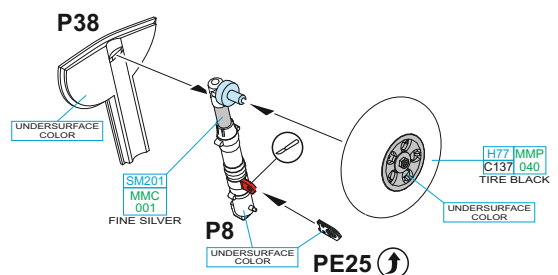

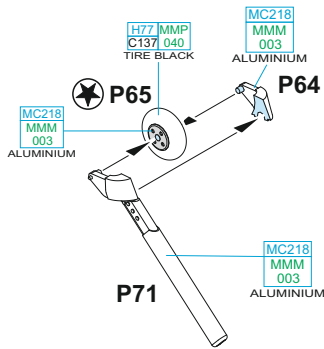
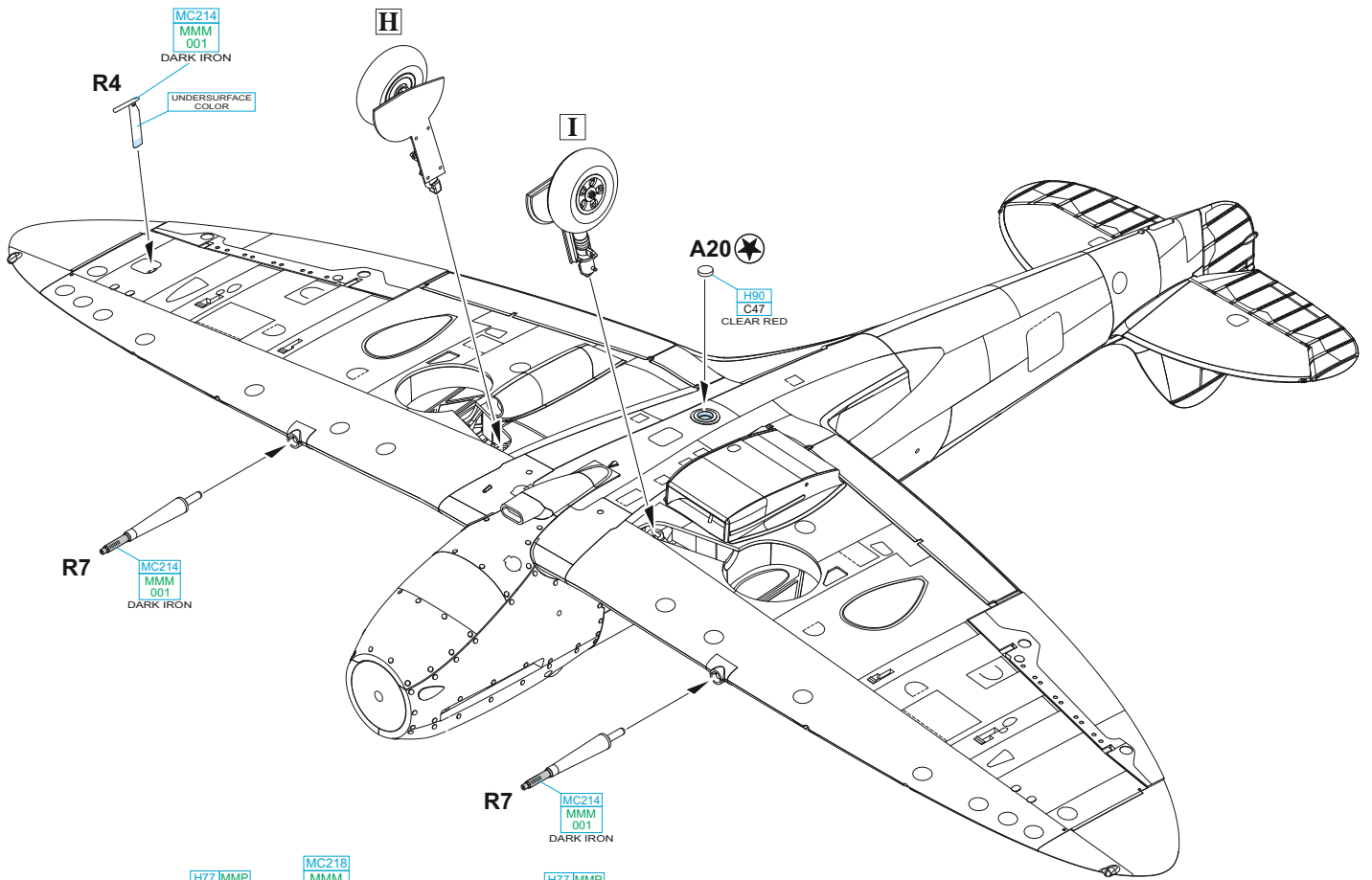

?

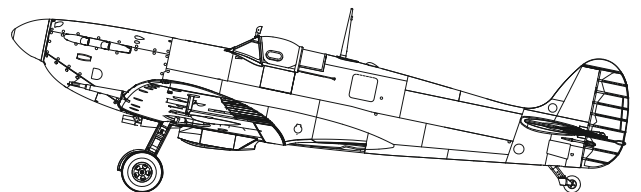
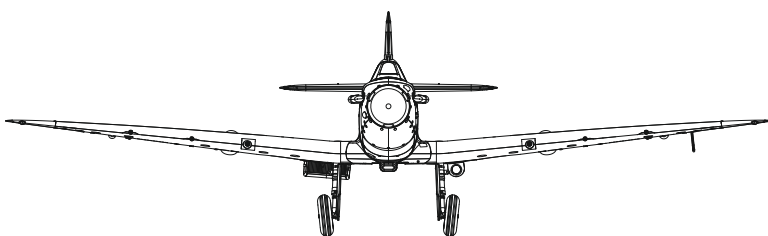
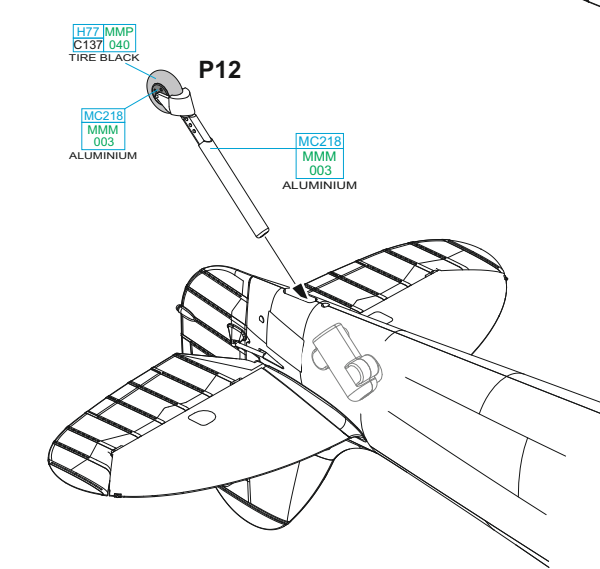

J

A7 ? A10 - MARKINGS A, F, C
A15 ? A16 - MARKINGS B, D, E

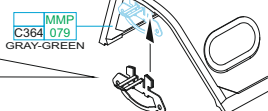
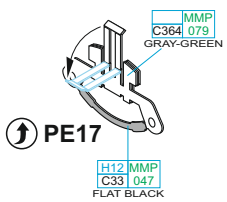

A7 ? A10
?
A15 ? A16

K

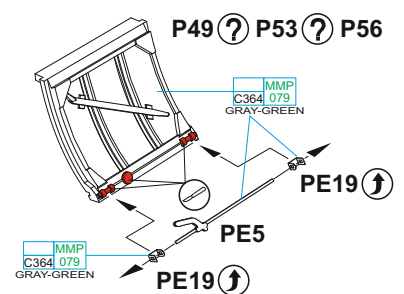

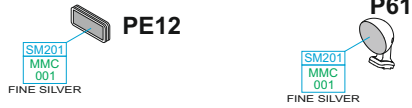
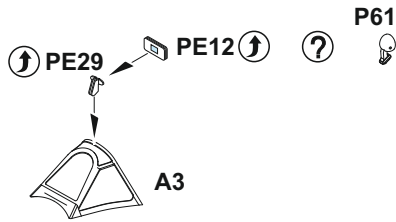
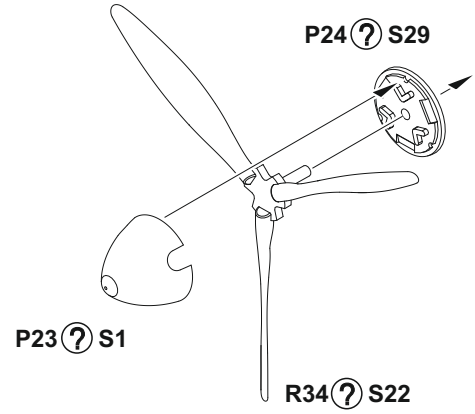
LPE12, PE29 - MARKINGS **B, C, E, F**P61 - MARKING **A****M**P23, P24, R34 - MARKINGS **C, E, F**S1, S22, S29 - MARKINGS **A, B, D****N** ?

starboard side

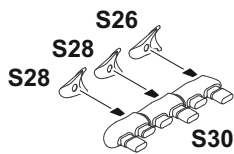

port side

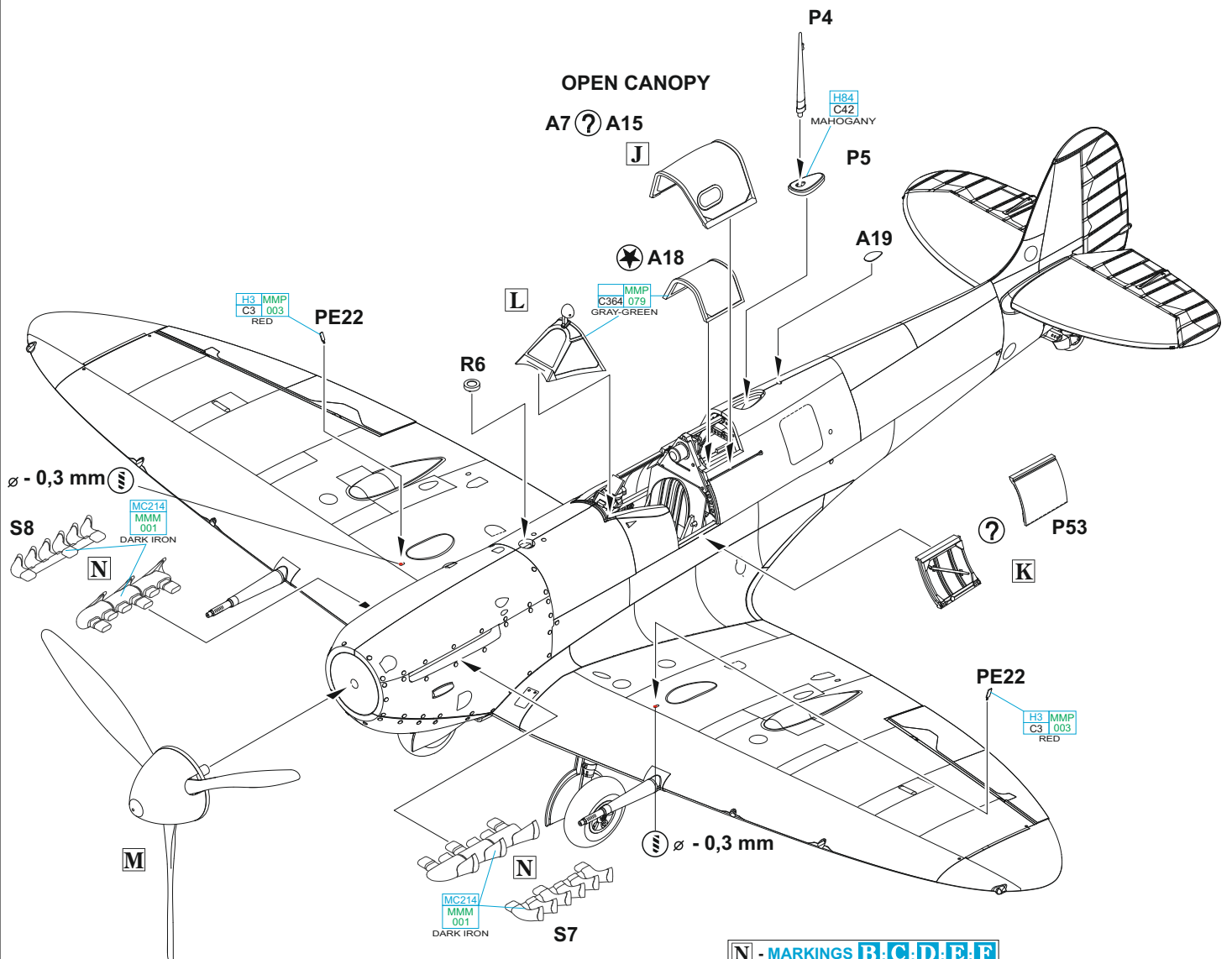
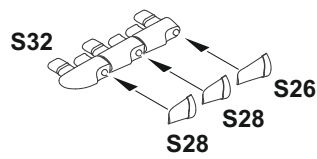
**N** - MARKINGS **B, C, D, E, F**S7, S8 - MARKING **A**

CLOSED CANOPY

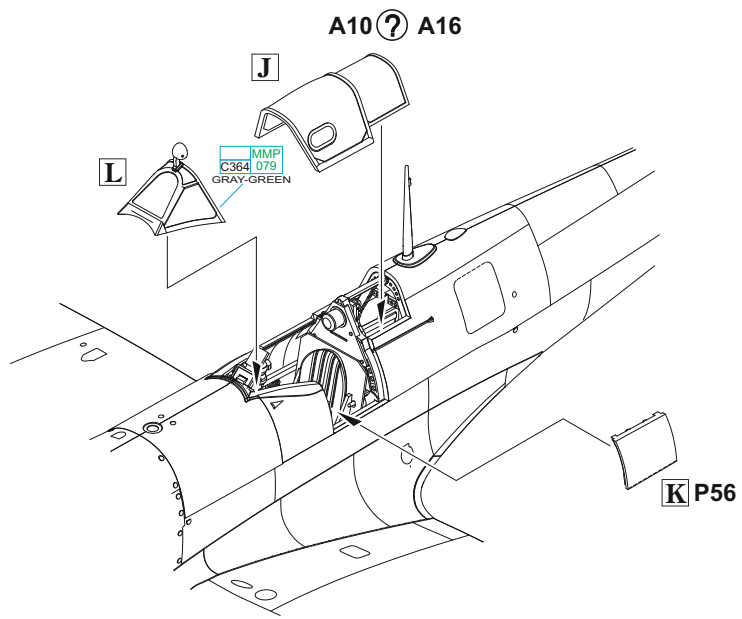

MARKINGS **A, B, C, D, E** ONLY

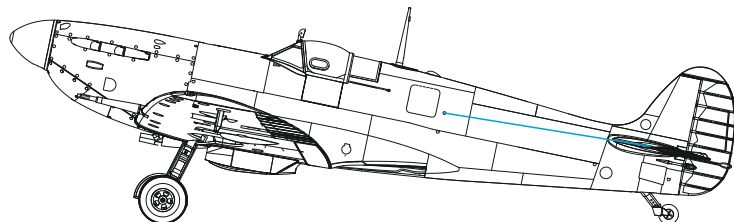
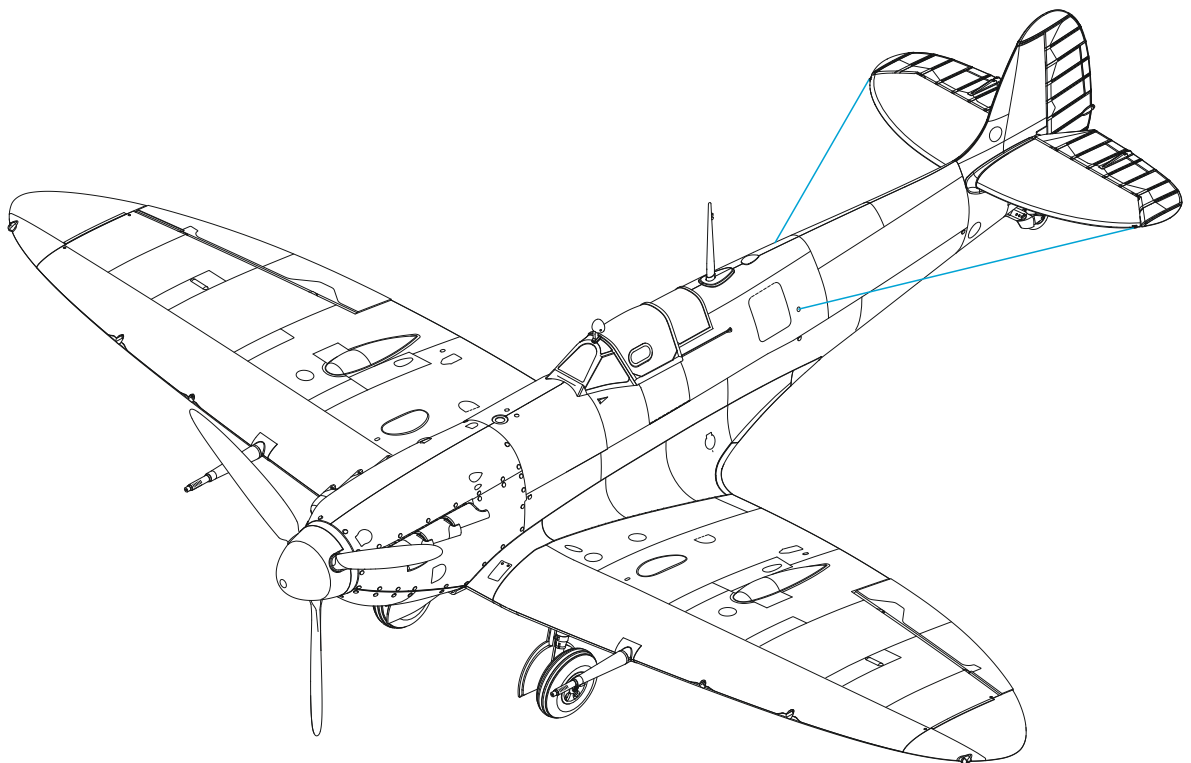

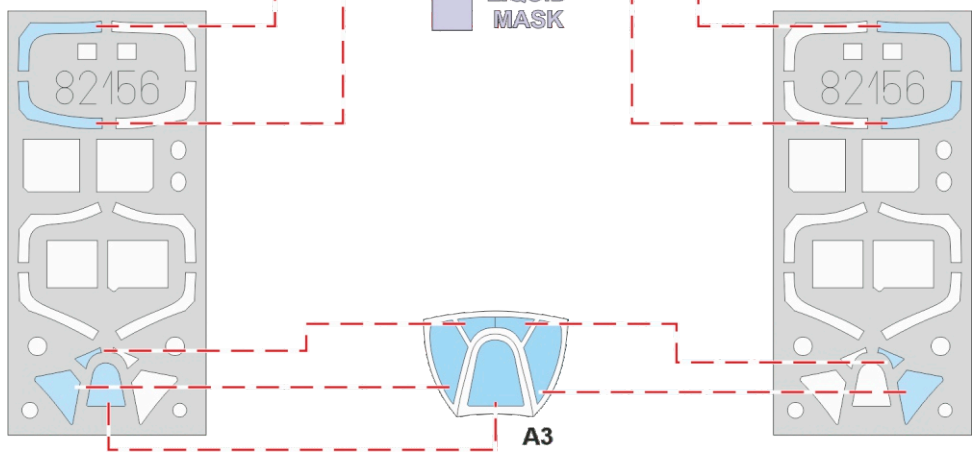
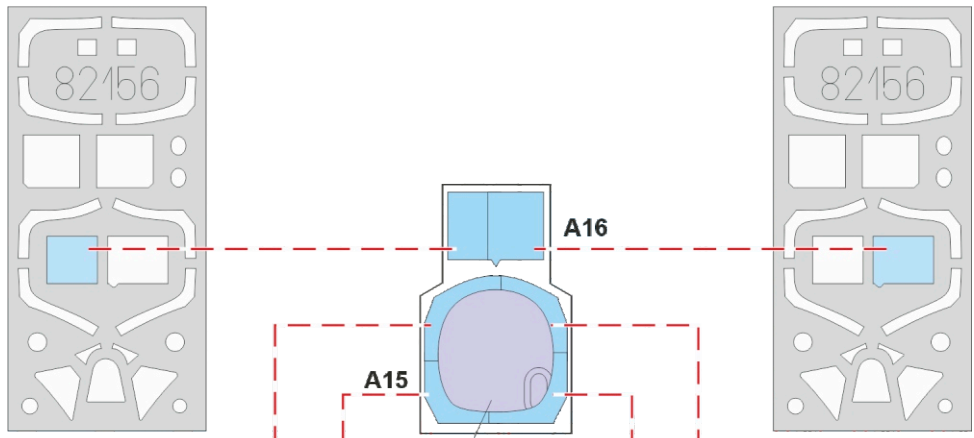
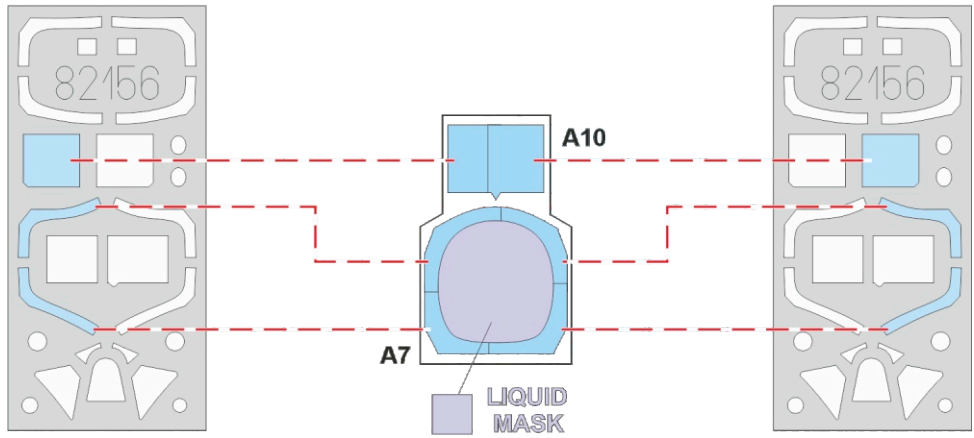
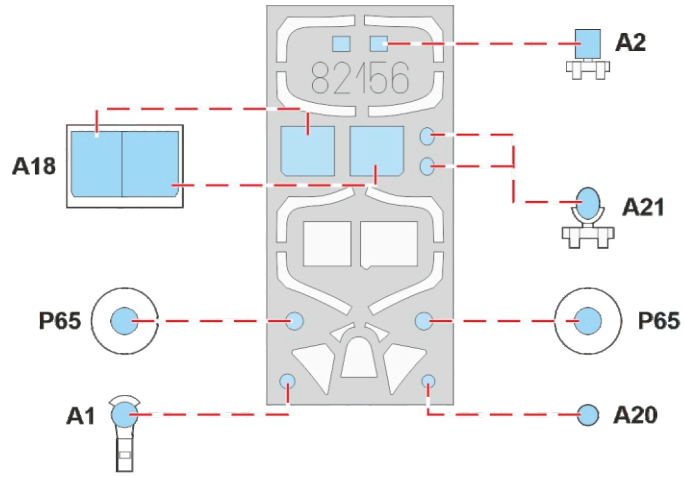

A EP120, S/Ldr Geoffrey W. Northcott, CO of No. 402 Squadron RCAF, RAF Merston, West Sussex, Great Britain, June–November 1943

Canadian Geoffrey Wilson Northcott was born in Rapid City, Manitoba, in 1920. Prior to joining the RCAF in June of 1940, he worked on the family farm. On completing basic training in January 1941, he was moved to Britain and underwent operational training with No. 52 OTU in Debden. This was followed by assignment to No. 401 Squadron RCAF. At the beginning of May 1942, he boarded the USS Wasp and headed off to Malta, where he arrived together with his Spitfire on the 9th of the month. He was assigned to No. 603 Squadron and soon made a name for himself in combat. After the unit was decommissioned in August, he was transferred to No. 229 Squadron, but did not stay for long, as by the end of the month, he was back in England with No. 53 OTU. In May 1943, he was named CO of No. 416 Squadron RCAF, but was then reassigned to No. 402 "City of Winnipeg" Squadron RCAF, which he led from June 1943, to July 1944. In January 1945, he would become the CO of the elite No. 126 (RCAF) Wing, and remained in that post through to March, 1946. In 1949, he went into the Reserves, and finally left the RCAF in 1955. Over the course of the Second World War, he was awarded the DFC with Bars and the DSO for nine confirmed kills, one probable and eight damaged aircraft. Six of the kills (four Bf 109s and a pair of Fw 190s) were gained while flying his personal Spitfire EP120.

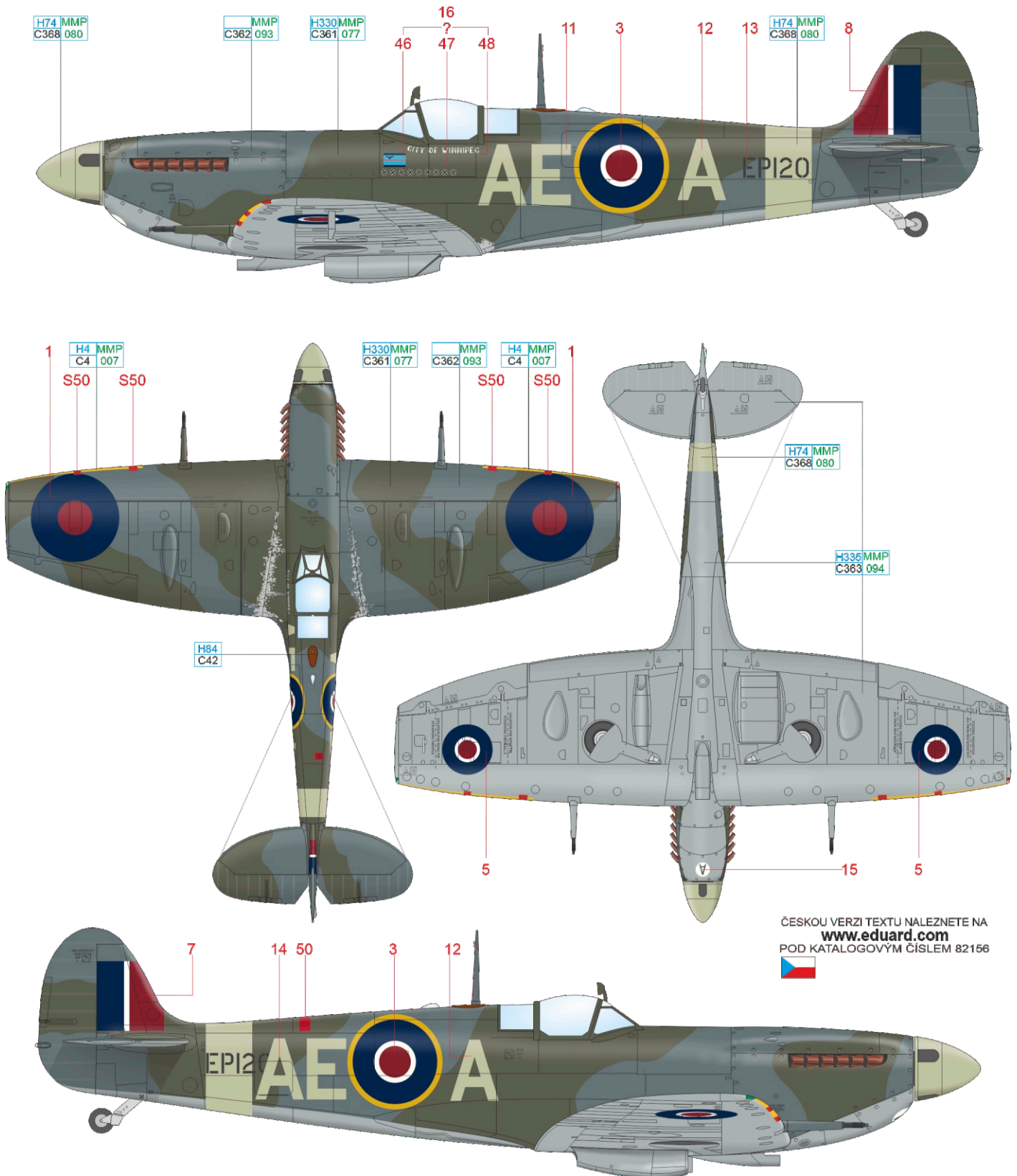

ČESKOU VERZI TEXTU NALEZNETE NA
www.eduard.com
 POD KATALOGOVÝM ČÍSLEM 82156

SKY	H74 MMP C368 080	MEDIUM SEA GRAY	H335 MMP C363 094	OCEAN GRAY	MMP C362 093	DARK GREEN	H330 MMP C361 077	YELLOW	H4 MMP C4 007	MAHOGANY	H84 C42
-----	---------------------	--------------------	----------------------	---------------	-----------------	---------------	----------------------	--------	------------------	----------	------------

B AB276, F/Lt Václav Hájek, No. 313 (Czechoslovak) Squadron, RAF Hornchurch, Great Britain, January–June 1942

Spitfire Mk.Vb AB276 served operationally with No. 313 (Czechoslovak) Squadron from January 13, 1942 to June 8 of the same year. It was most often flown by F/Lt Václav Hájek, who on April 10, 1942 likely shot down a I./JG 26 Fw 190 south of Gravelines. Other pilots who flew missions in AB276 were Sgt. K. Pavlík, Sgt. F. Bönisch and P/O V. Michálek. No. 313 (Czechoslovak) Squadron Spitfires are known for their carrying Walt Disney characters through the first half of 1942, when the unit was a component of Hornchurch Wing. The author of the artwork was Sgt. Karel Pavlík, who put his talents as a graphic artist to good use and applied the characters below the windscreen of individual aircraft according to the wishes of the pilots. The rendering of the kitten "Figaro" with the inscription "Mnoho štěstí" (Best of Luck) is probably the most recognized because of a photograph of it, in which Sgt. Pavlík is shown during its creation. Its likeness also appears on a granite monument near to where Sgt. Pavlík crashed, not far from the town of Dranouter, Belgium.

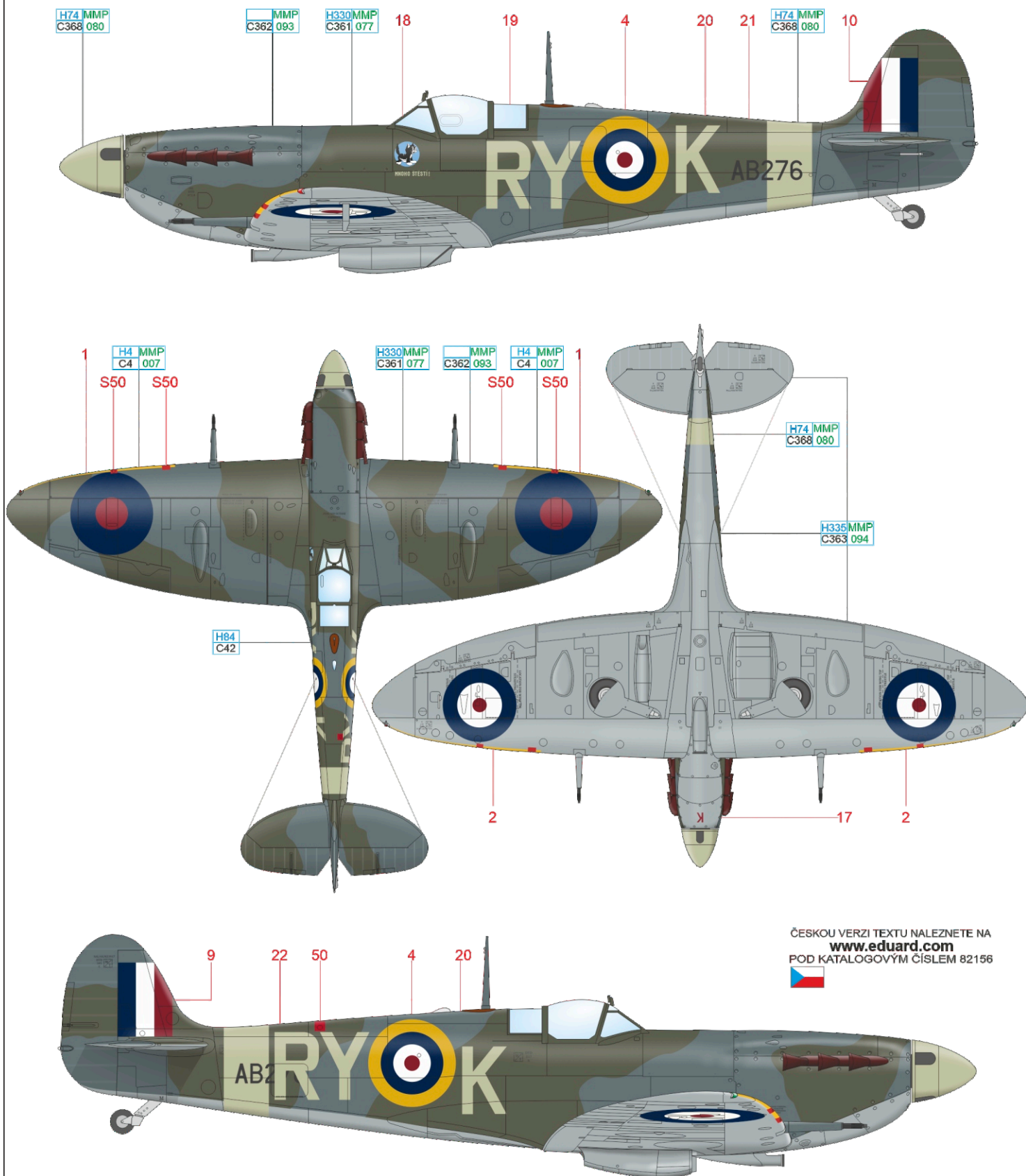

ČESKOU VERZI TEXTU NALEZNETE NA
www.eduard.com
 POD KATALOGOVÝM ČÍSLEM 82156



- | | | | | | | | | | | | |
|-----|---------------------|--------------------|----------------------|---------------|-----------------|---------------|----------------------|--------|------------------|----------|------------|
| SKY | H74 MMP
C368 080 | MEDIUM
SEA GRAY | H335 MMP
C363 094 | OCEAN
GRAY | MMP
C362 093 | DARK
GREEN | H330 MMP
C361 077 | YELLOW | H4 MMP
C4 007 | MAHOGANY | H84
C42 |
|-----|---------------------|--------------------|----------------------|---------------|-----------------|---------------|----------------------|--------|------------------|----------|------------|

C AB184, Sgt. Olav Dionne, No. 332 (Norwegian) Squadron, RAF North Weald, Essex, Great Britain, August 1942

Norwegian pilot Olav Dionne served with No. 332 (Norwegian) Squadron through 1942–1943. His first kill was gained during combat over Dieppe on August 19, 1942, when he downed a Do 217 flying this aircraft. In 1943, he was made an officer, and flying Spitfire Mk.IXs, he recorded another four confirmed kills. After the war, he entered the Norwegian civil aviation scene, and was killed in 1946, a mishap while piloting a Ju 52. Spitfire AB184, which Dionne flew in August, 1942, was one of the most striking aircraft to fly with No. 332 (Norwegian) Squadron. The cockpit door bore the Norwegian flag, an inscription "Joe II" appeared below the windscreen, and the fuel tank cover carried artwork of a snorting bull, above which was a swastika, denoting the kill over Dieppe.

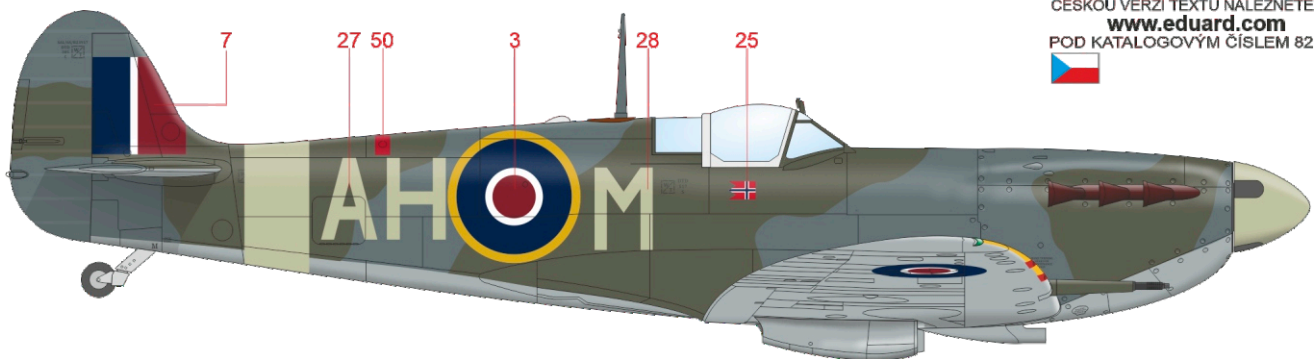
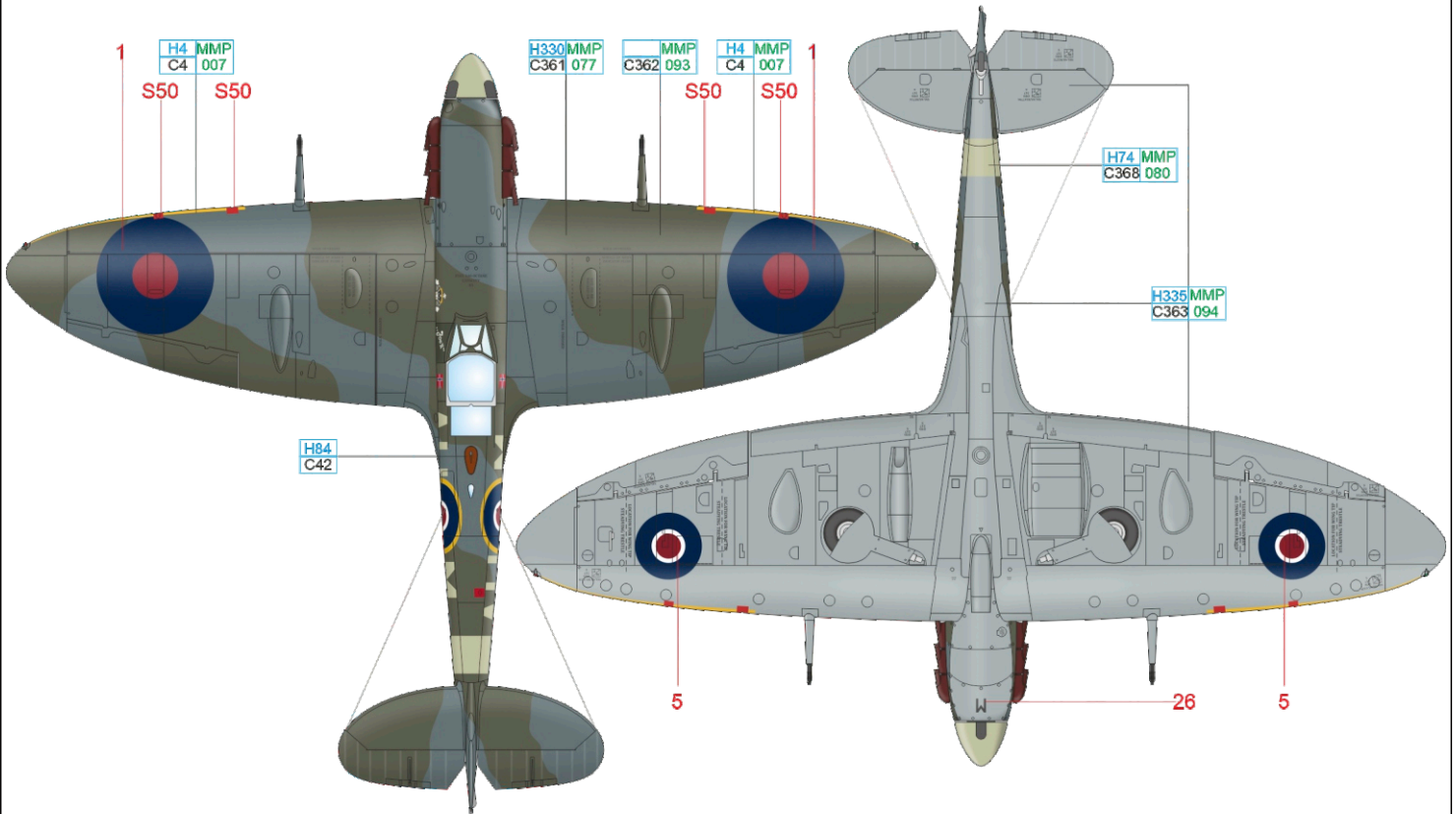
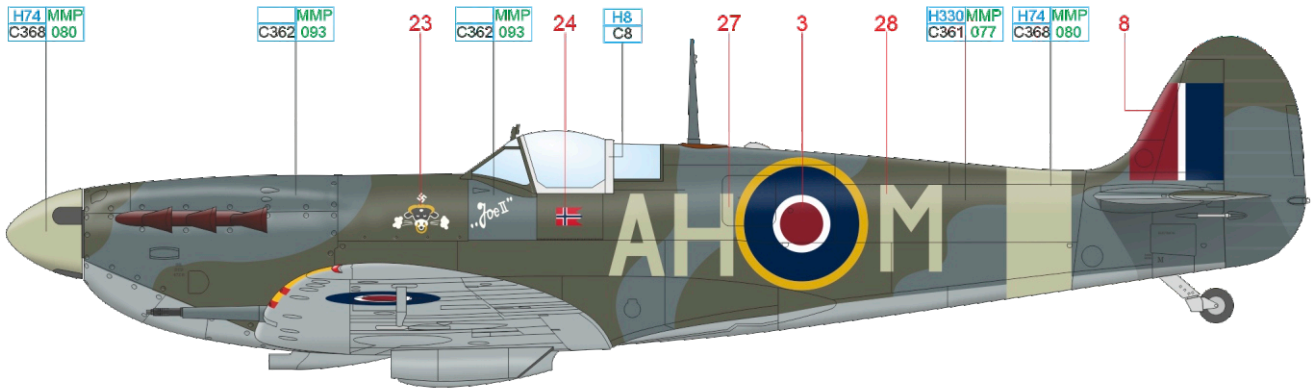

ČESKOU VERZI TEXTU NALEZNETE NA
www.eduard.com
POD KATALOGOVÝM ČÍSLEM 82156



SILVER H8 C8

SKY H74 MMP C368 080 MEDIUM SEA GRAY H335 MMP C363 094 OCEAN GRAY MMP C362 093 DARK GREEN H330 MMP C361 077 YELLOW H4 MMP C4 007 MAHOGANY H84 C42

eduard

D EN794, S/Ldr Yvan du Monceau de Bergendal, No. 350 (Belgian) Squadron, RAF Redhill, Surrey, Great Britain, July–December 1942

The most successful Belgian fighter ace, Yvan du Monceau de Bergendal was born on December 10, 1915 in Fullham. He underwent training at Sutton Bridge with No. 56 OTU, and his first combat assignment was with No. 253 Squadron. In April 1941, he was transferred to No. 609 Squadron, where he would claim his first aerial victory. In March 1942, he became a Flight Leader with No. 350 (Belgian) Squadron, and in June 1943, he was named CO of No. 349 (Belgian) Squadron. After the completion of his combat tour in June 1944, he was sent to North America and in 1945, he returned to Europe as a Staff Member of the Belgian Section of the RAF. Over the course of his military career, he is credited with eight confirmed kills, three probables and six damaged, giving him a ratio of 3:1:2 respectively while flying Spitfire Mk.Vb EN794. The Spitfire serialised EN794, flown by "Duke" (he did hold the title) as B Flight Leader of No. 350 (Belgian) Squadron, showed signs of camouflage touchups on the engine cowling as a result of the removal of the white identification stripes that were applied for Operation Rutter in July 1942. The change also affected the tally of kills under the windscreen. The presentation inscription USOKE is in honor of the inhabitants of the Belgian Congo, which came together for the purchase of sixteen Spitfires for Belgian pilots fighting in the ranks of No. 350 (Belgian) Squadron.

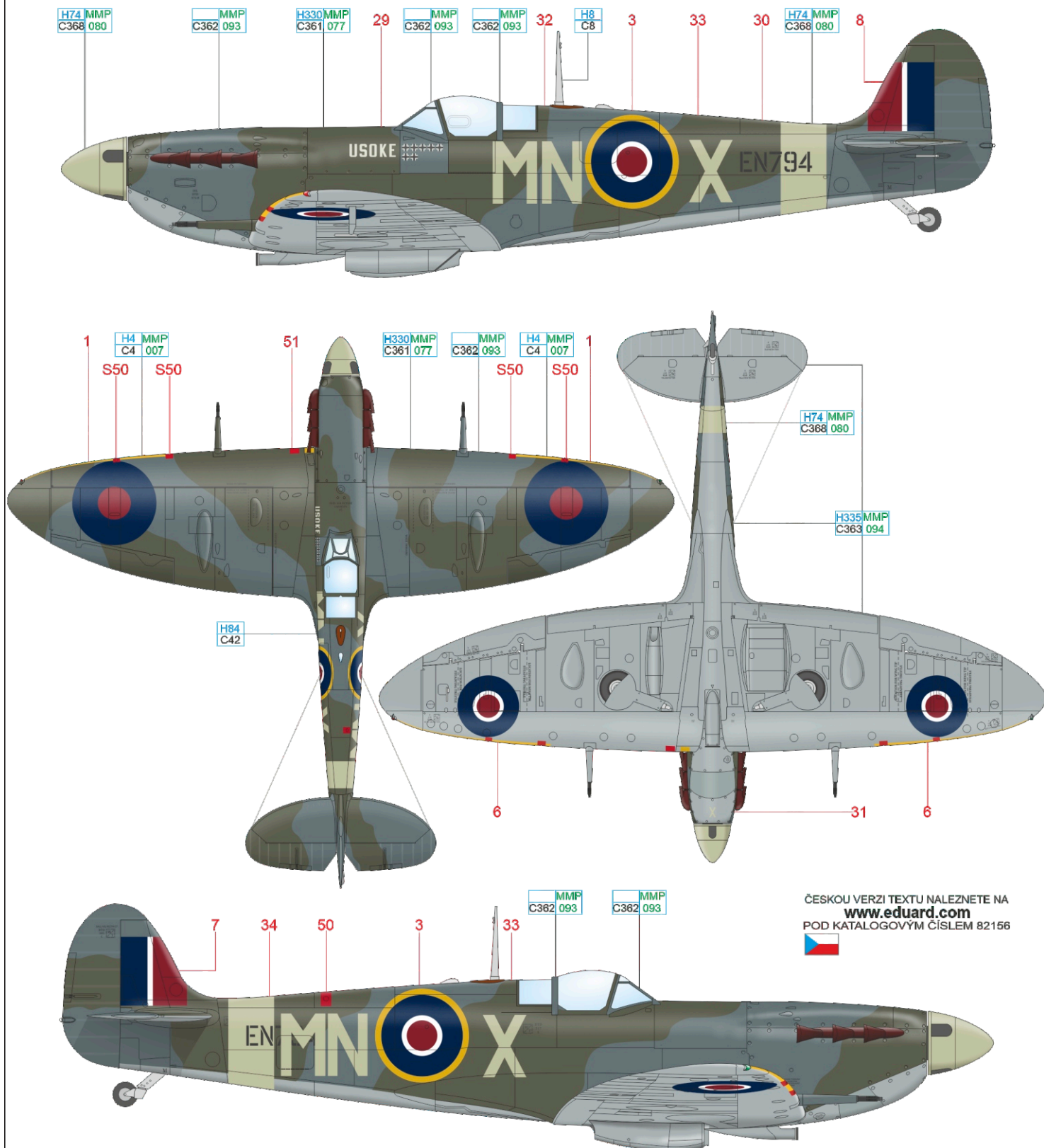

ČESKOU VERZI TEXTU NALEZNETE NA
www.eduard.com
 POD KATALOGOVÝM ČÍSLEM 82156



SILVER	H8 C8										
SKY	H74 MMP C368 080	MEDIUM SEA GRAY	H335 MMP C363 094	OCEAN GRAY	MMP C362 093	DARK GREEN	H330 MMP C361 077	YELLOW	H4 MMP C4 007	MAHOGANY	H84 C42

E AA853, W/Cdr Stefan Witorzenc, No. 1 Polish Fighter Wing, RAF Heston, Great Britain, Beginning of July 1942

Stefan Witorzenc was born in 1908, and joined the Polish Air Force in the 1930's. After the defeat of his country, he fled to England, where between August and September 1940 he achieved five kills while with No. 501 Squadron, the unit with which he served out the Battle of Britain. On November 22, 1940, he was reassigned to No. 306 (Polish) Squadron, where he served in the function of Flight Leader, and in May 1941, he was given command No. 302 (Polish) Squadron. In February 1942, he took command of No. 1 Polish Fighter Wing in Kirton-in-Lindsey and he was awarded the DFC in June 1942. His combat tour concluded in September, when he was assigned to the General Staff of No. 11 Group and then to Air Command as Polish Liaison Officer. In April 1944, he took command of No. 61 OTU and held this post through to the end of the war. Spitfire AA853, which Witorzenc flew at the beginning of July 1942, carried four white quick-identification bands around the nose, which were used as such by Fighter Command during Operation Rutter between July 4 and 7, 1942. Besides these bands, the spinner was also painted white (instead of the usual Sky) and two white bands were applied to the upper surfaces of the horizontal tails. Operation Rutter was called off for inclement weather and also other factors and was later replaced by the well-known Operation Jubilee.

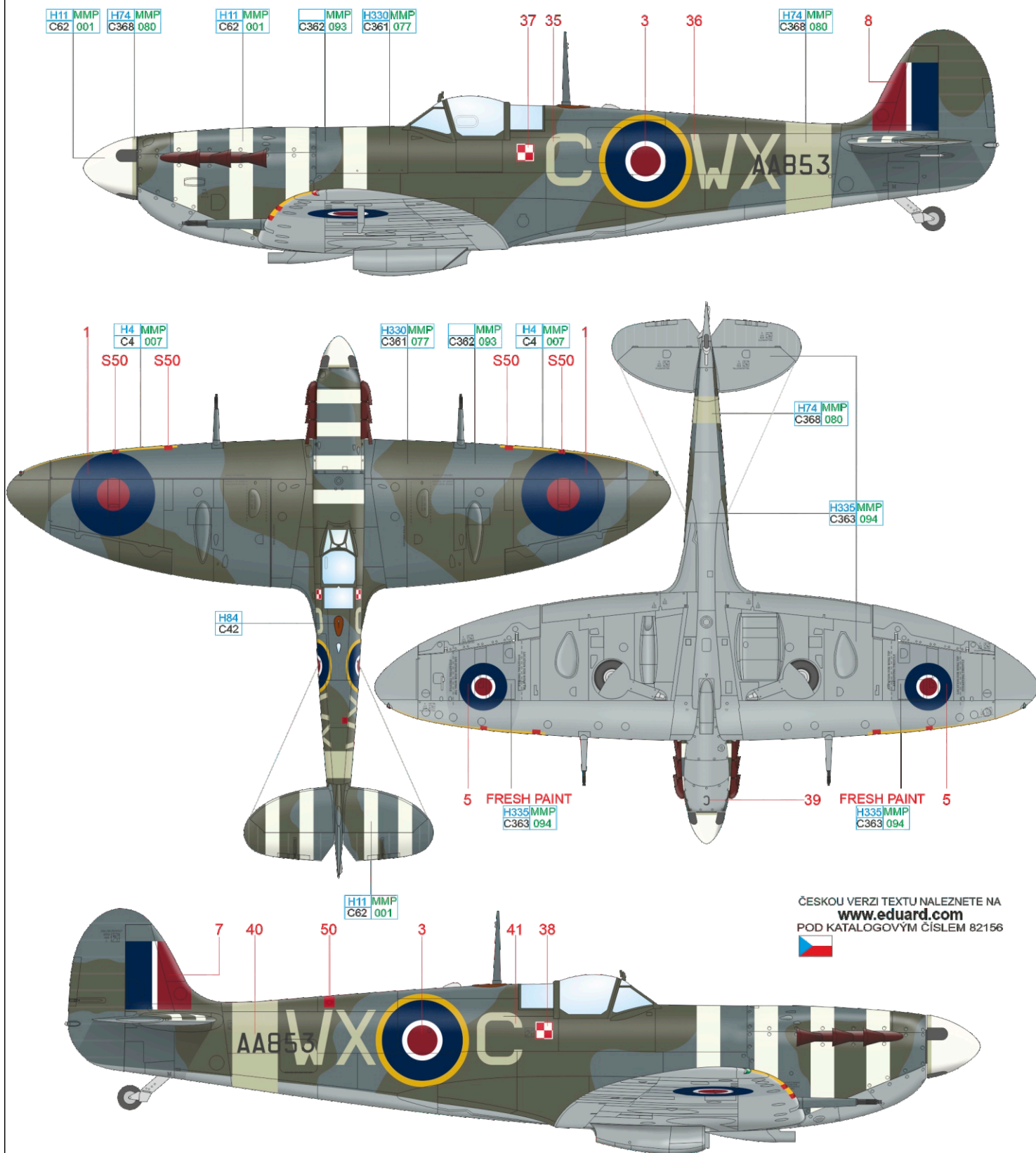

ČESKOU VERZI TEXTU NALEZNETE NA
www.eduard.com
 POD KATALOGOVÝM ČÍSLEM 82156



- | | | | | | | | | | | | | | |
|-----|---------------------|--------------------|----------------------|---------------|-----------------|---------------|----------------------|--------|------------------|-------|--------------------|----------|------------|
| SKY | H74 MMP
C368 080 | MEDIUM
SEA GRAY | H335 MMP
C363 094 | OCEAN
GRAY | MMP
C362 093 | DARK
GREEN | H330 MMP
C361 077 | YELLOW | H4 MMP
C4 007 | WHITE | H11 MMP
C62 001 | MAHOGANY | H84
C42 |
|-----|---------------------|--------------------|----------------------|---------------|-----------------|---------------|----------------------|--------|------------------|-------|--------------------|----------|------------|

F EP829, S/Ldr John J. Lynch, No. 249 Squadron, RAF Krendi, Malta, April–May 1943

John Joseph Lynch was born on February 3, 1918 in Alhambra, California. In 1941, he joined the RAF and his first assignment was with No. 232 Squadron. The following month, he was attached to No. 121 "Eagle" Squadron. This was followed by a stint with No. 71 "Eagle" Squadron, during which he shared in the destruction of a Ju 88 on April 17, 1942. In November 1942, he was transferred to Malta and assigned to No. 249 Squadron, with which he actively participated in its defense. At the beginning of 1943, he was promoted to Commander of the unit, and recorded a number of victories over Axis transport aircraft supplying Tunisia. The Ju 52 kill came about on April 28, being the 1,000th kill recorded by the defenders of Malta. In July 1943, he was reassigned to the USAAF, but saw no combat with the service. Spitfire EP829, with which Lynch flew from February to May, 1943 as a member of No. 249 Squadron, was a part of Operation "Train", and represented the final shipment of Spitfires to the defenders of Malta, delivered by an aircraft carrier. EP829 initially had clipped wings, and later flew with the standard span wings. The main fuel tank cover carried the Squadron Commander marking and seven kill markings that were recorded up to April 28, 1943. Below the windscreen, there was an inscription "Malta's 1000", in honor of that kill over Malta. Over his combat career, Lynch recorded 17 kills (ten individual and seven shared), along with a single probable and two damaged enemy aircraft.

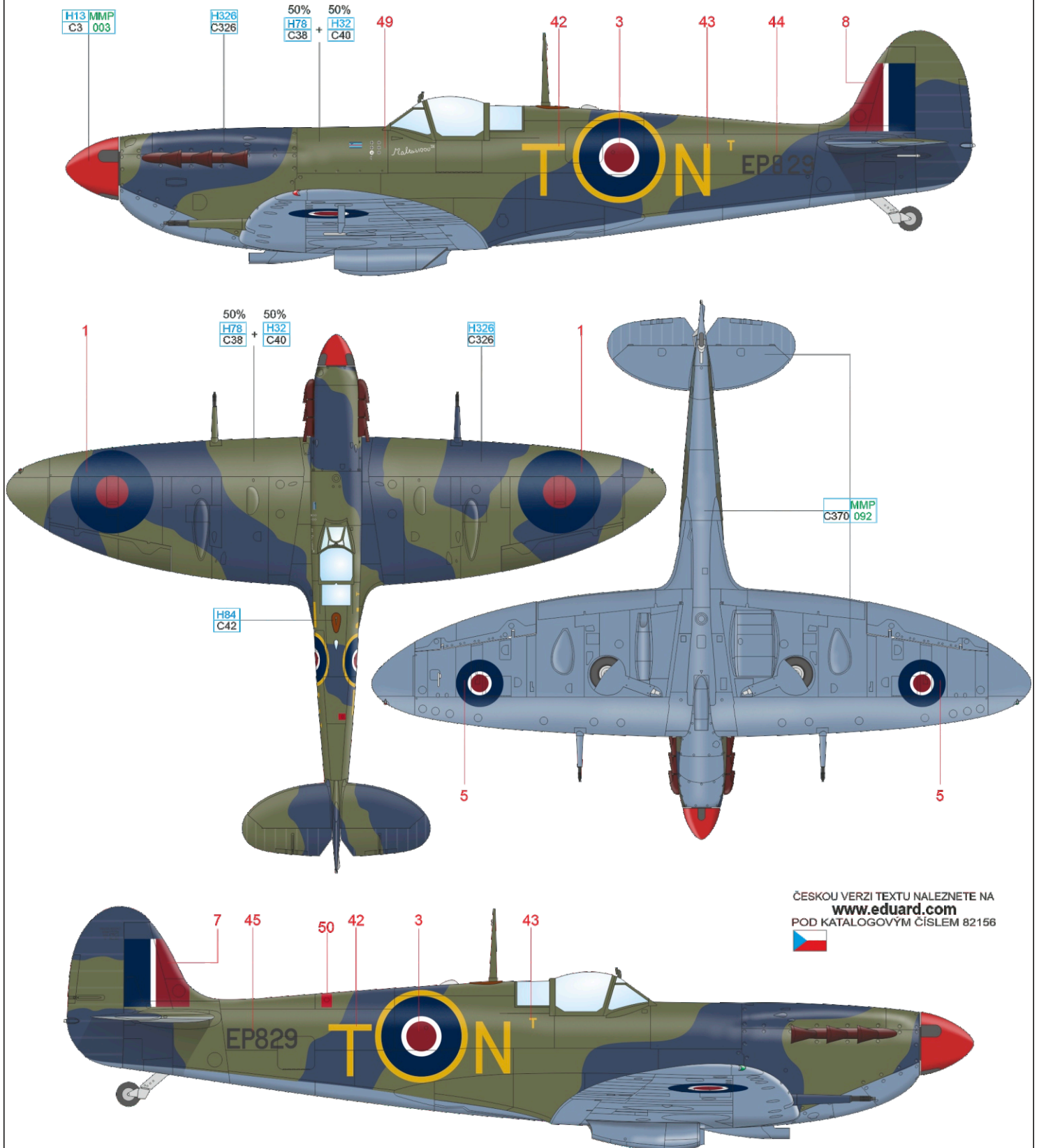

ČESKOU VERZI TEXTU NALEZNETE NA
www.eduard.com
 POD KATALOGOVÝM ČÍSLEM 82156



AZURE BLUE	MMP C370 092	FIELD GRAY	H32 C40	OLIVE GREEN	H78 C38	DARK BLUE	H326 C326	RED	H13 MMP C3 003	MAHOGANY	H84 C42
------------	--------------	------------	---------	-------------	---------	-----------	-----------	-----	----------------	----------	---------

Spitfire Mk.Vb late

STENCILING POSITIONS

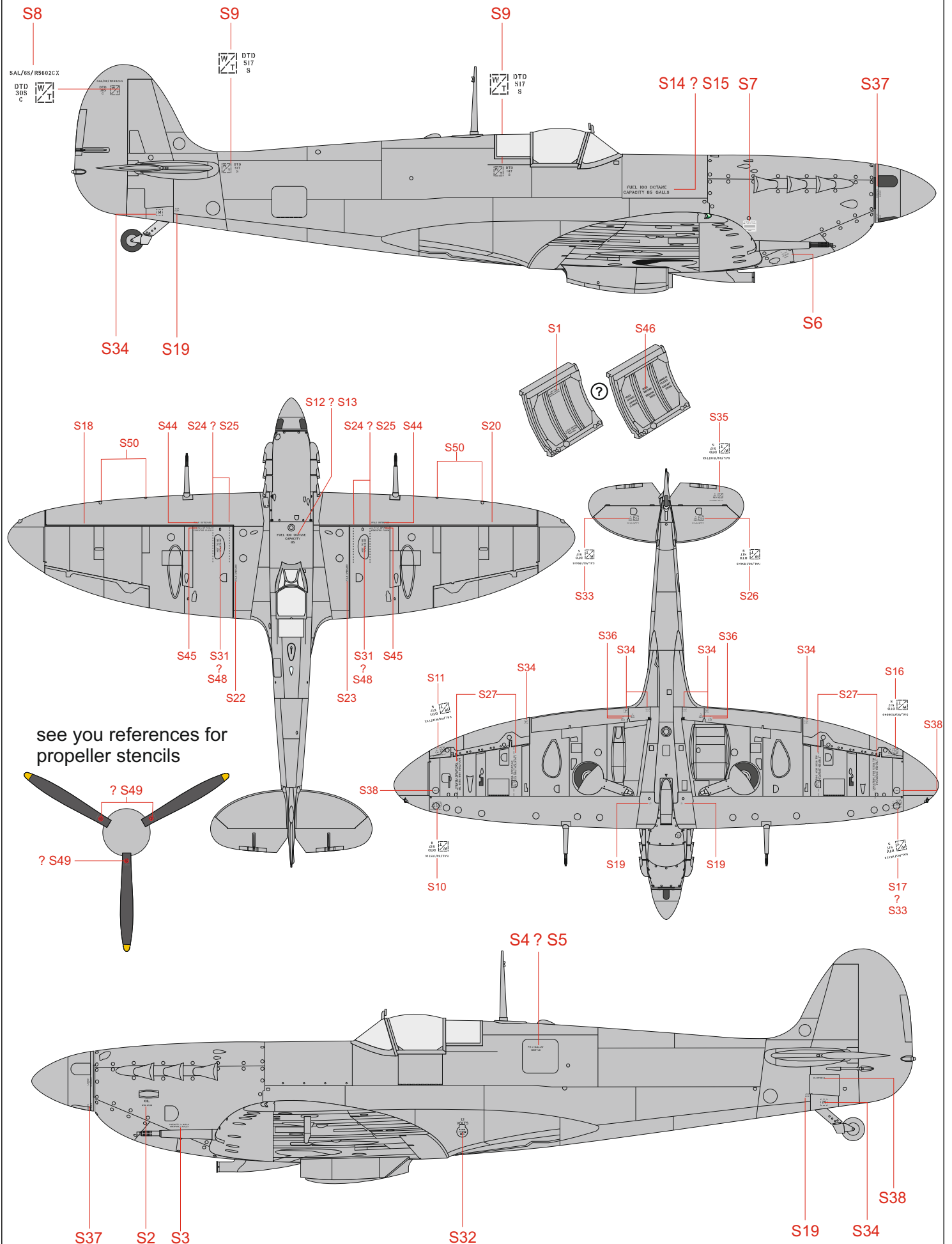

see you references for propeller stencils