

Deluxe Kit P-40B TIGER SHARK

The P-40B Tiger Shark, made famous by Gen. Claire Chennault's "Flying Tigers" in China, was a direct off-spring of the P-36 (Hawk 75-A) built by the Curtiss-Wright Corp. Airplane Division.

The original XP-40 was a production Hawk 75A modified for the installation of the more powerful Allison V-12, 1,150 h.p. liquid cooled engine. This new fighter was flown for the first time in October, 1938.

The P-40 had a wing span of 37 ft. 3.5 in., fuselage length of 31ft. 8.5 in., and a height of 10 ft. 7 in. Armament consisted of two .50 cal. machine guns in the nose and two .30 cal. machine guns in each wing.

Although lacking somewhat in maneuverability and rate of climb, the P-40's top speed of 352 mph. coupled with its rugged construction, armor plating and fast diving speed, enabled it to hold its own against most of the fighter planes in existence at that time.

During the war years the P-40 fought on many battle fronts and bore the insignia of various countries. Among these were the United States, Britain, Australia, China, South Africa, Turkey and Russia. The P-40 and P-40B's were the first of a long line of P-40's whose performance improved with each modification.



* REPEAT SEVERAL TIMES
* A REPETER PLUSIEURS FOIS



* OPTIONAL PARTS
* PIECES EN OPTION



* DECAL
* DECAL COMANIE



* ALTERNATIVE ASSEMBLY
* ENSEMBLAGE ALTERNATIVE



* CEMENT TOGETHER
* A COLLER



* REMOVE AND THROW AWAY
* A RETIRER ET JETER



* DO NOT CEMENT
* NE PAS COLLER

READ THIS BEFORE YOU BEGIN

- * Study the assembly drawings.
- * Each plastic part is identified by a number.
- * In the assembly drawings, some parts will be marked by a star (★) to indicate chrome plated plastic.
- * For better paint and decal adhesion, wash the plastic parts in a mild detergent solution. Rinse and let air dry.
- * Check the fit of each piece before cementing in place.
- * Use only cement for polystyrene plastic.
- * Scrape plating and paint from areas to be cemented.
- * Allow paint to dry thoroughly before handling parts.
- * Any unused parts may be discarded.

DECAL APPLICATION INSTRUCTIONS

1. Cut desired decal from sheet.
2. Dip decal in water for a few seconds.
3. Place wet decal on paper towel.
4. Wait until decal is movable on paper backing.
5. Place decal in position on model, face up and slide backing away.
6. Press out air bubbles with a soft damp cloth.
7. Milkiness that may appear is for better decal adhesion and will dry clear. Wipe away any excess adhesive.
8. Do not touch decal until fully dry.
9. Allow the decals 48 hours to dry before applying clear coat.

NOTE: Decals are not compatible with setting solutions or solvents.

LIRE CE QUI SUIT AVANT DE COMMENCER

- * Etudier les schémas de montage.
- * Chaque pièce en plastique est identifiée par un numéro.
- * Sur les schémas de montage, certaines pièces sont marquées d'une étoile (★) pour indiquer qu'elles sont en plastique chromé.
- * Pour une meilleure prise de la peinture et des autocollants, laver les pièces en plastique avec une solution détergente peu concentrée. Les rincer et les laisser sécher à l'air.
- * Vérifier que chaque pièce s'ajuste bien avant de la coller en place.
- * N'utiliser que de la colle pour polystyrène.
- * Gratter les parties à coller pour enlever le chrome et la peinture.
- * Laisser la peinture bien sécher avant de manipuler les pièces.
- * Toute pièce inutilisée peut être jetée.

DIRECTIVES D'APPLICATION DES AUTOCOLLANTS

1. Découper l'autocollant désiré de la feuille.
2. Tremper l'autocollant dans de l'eau pendant quelques secondes.
3. Placer l'autocollant mouillé sur une serviette en papier.
4. Attendez que l'autocollant puisse être déplacé sur son support en papier.
5. Mettre l'autocollant en position sur le modèle face sur le dessus et faire glisser le support pour l'enlever.
6. Appuyer avec un chiffon doux humide pour éliminer les bulles d'air.
7. La substance laiteuse qui peut apparaître est destinée à améliorer l'adhésion de l'autocollant et devient incolore au séchage. Essuyer pour enlever tout excédent d'adhésif.
8. Ne pas toucher l'autocollant tant qu'il n'est pas bien sec.
9. Laisser l'autocollant sécher pendant 48 heures avant d'appliquer une couche transparente.

REMARQUE: Les autocollants sont incompatibles avec les solutions de fixation ou les solvants.

**WARNING: CEMENT FLAMMABLE.
SKIN AND EYE IRRITANT.
CONTAINS: METHYL ETHYL KETONE.**

PRECAUTIONS: Avoid prolonged contact with skin. Wash hands immediately after use. When using wear impermeable gloves. Keep away from eyes. Avoid inhalation and ingestion. **KEEP OUT OF REACH OF SMALL CHILDREN.**

FIRST AID: If eye contact occurs, rinse with tap water for 5 to 10 minutes. If skin contact occurs, wash with soap and water for 5 minutes. If dizziness, uncoordination or slurred speech occur, move to a well ventilated area, wash hands, and remove any contaminated clothing. If any symptoms persist, seek medical attention. For further health information contact a poison control center.

**AVERTISSEMENT: COLLE INFLAMMABLE.
IRRITE LA PEAU ET LES YEUX.
CONTIENT DE LA METHYLETHYLKETONE.**

PRECAUTIONS: Eviter tout contact prolongé avec la peau. Se laver les mains immédiatement après utilisation. Utiliser en portant des gants imperméables. Ne pas approcher des yeux. Eviter toute inhalation ou ingestion. **MAINTENIR HORS DE PORTEE DES ENFANTS.**

PREMIERS SECOURS: En cas de contact avec les yeux, rincer ceux-ci à l'eau du robinet pendant 5 à 10 minutes. En cas de contact avec la peau, laver celle-ci à l'eau savonneuse pendant 5 minutes. En cas de vertiges, de manque de coordination ou de diction indistincte, se rendre dans un endroit bien aéré, se laver les mains et ôter tout vêtement contaminé. Si l'un quelconque de ces symptômes persiste, consulter un médecin. Pour des informations sanitaires complémentaires, prendre contact avec un centre anti-poison.

This paint guide is provided to complete this kit as shown on the box.

Ce guide de peinture est fourni pour reproduire le modèle réduit qui apparaît sur la boîte.

Aluminum	Aluminum
Flat Black	Noir Mat
Chromate Green-Primer	Vert Chromate

If you have any questions or comments, call our hotline at: **(800) 833-3570** or, please write to:

Revell-Monogram Consumer Service Department, 8601 Waukegan Road, Morton Grove, Illinois 60053
Be sure to include the kit number, part number, description, your return address and phone number.

Visit our website: www.revell-monogram.com

1

COCKPIT ASSEMBLY

A

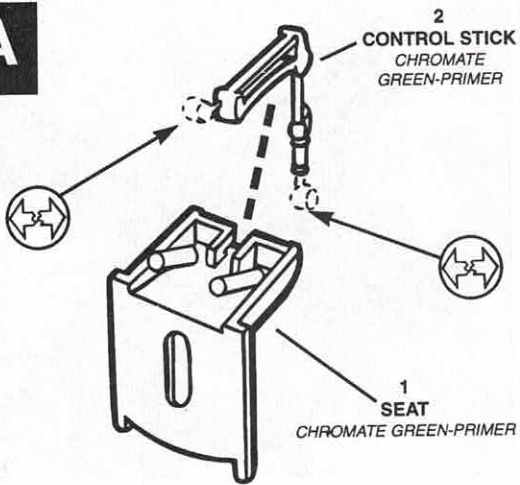

B

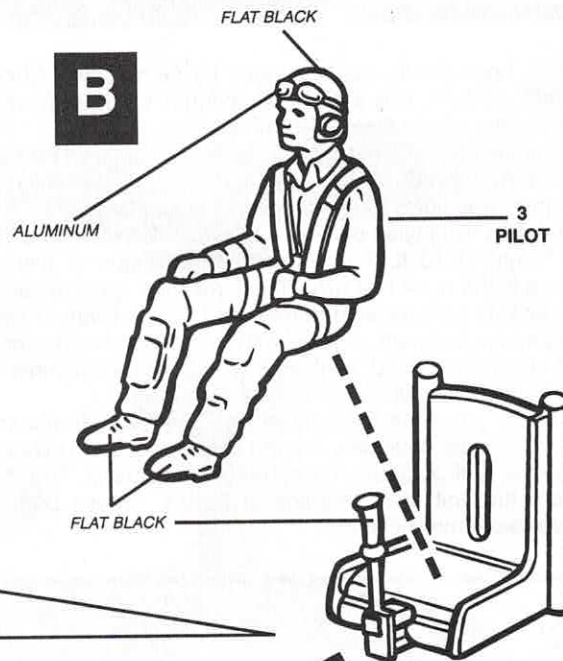

C

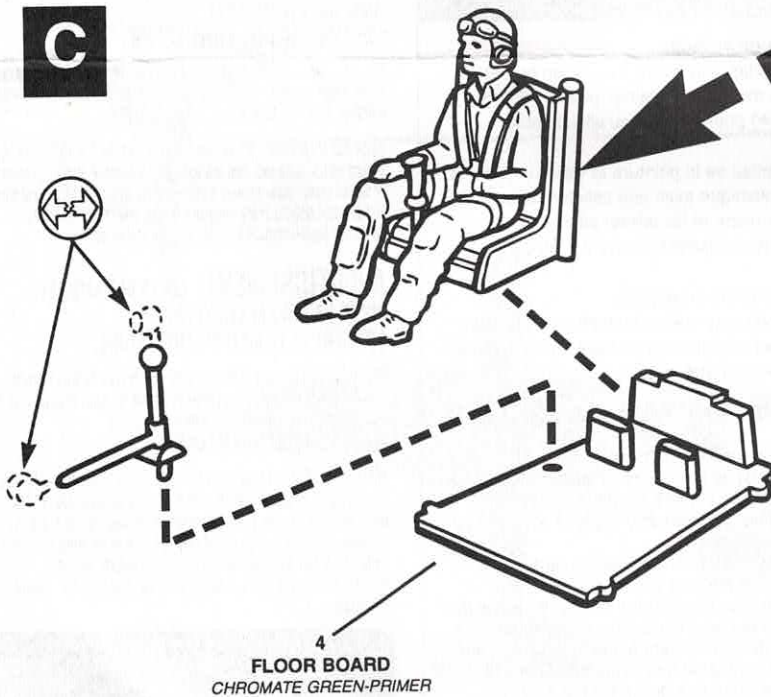

D

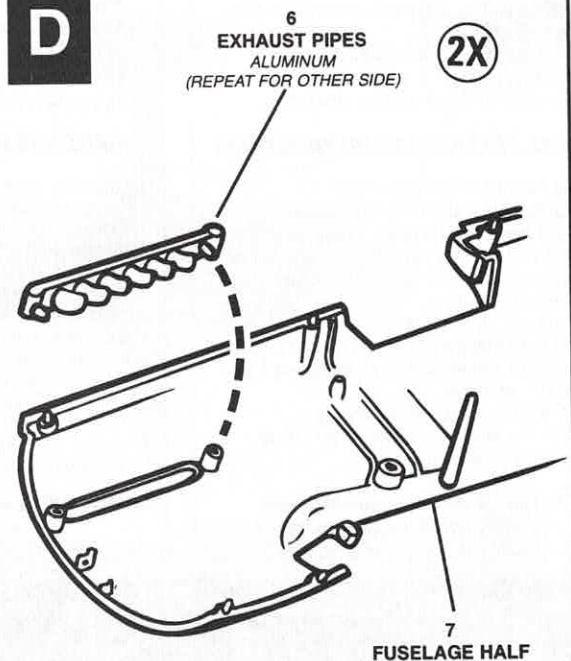

Helpful Hint
Scrape paint from
areas to be cemented.

1

COCKPIT ASSEMBLY CONTINUED

E

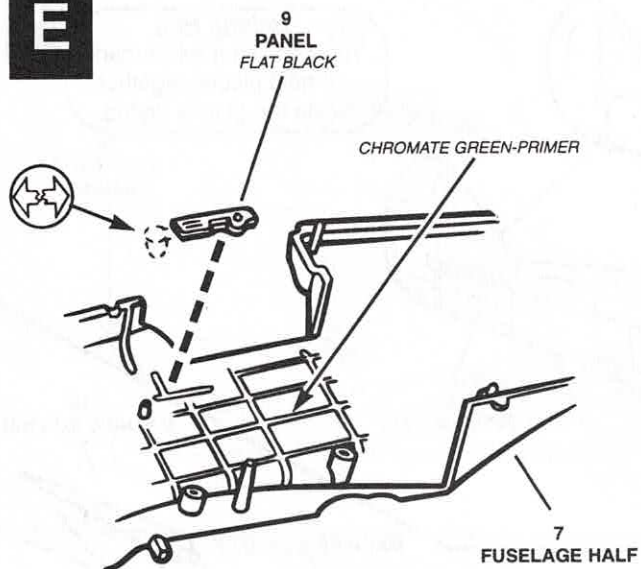

F

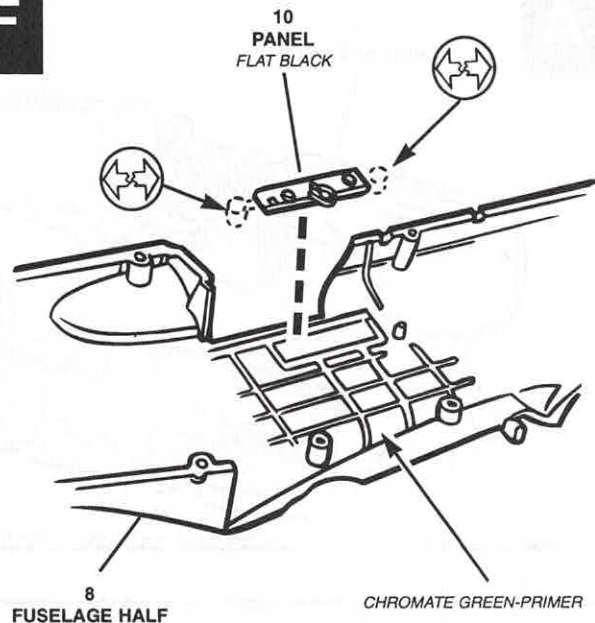

Helpful Hint

Paint parts first before cementing in place.

G

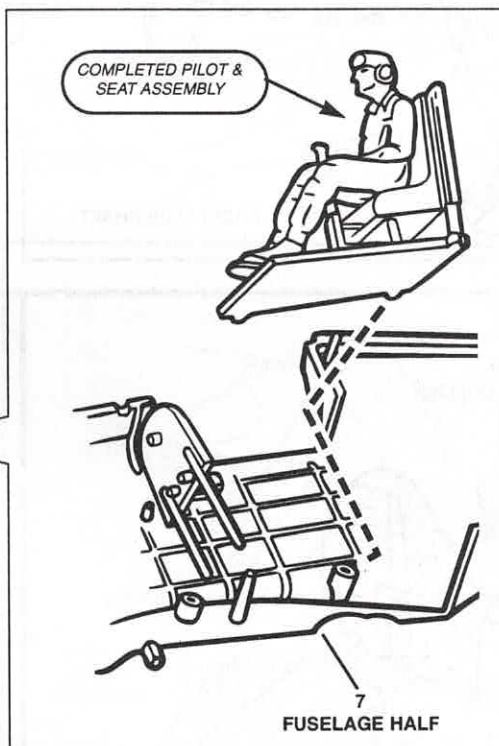
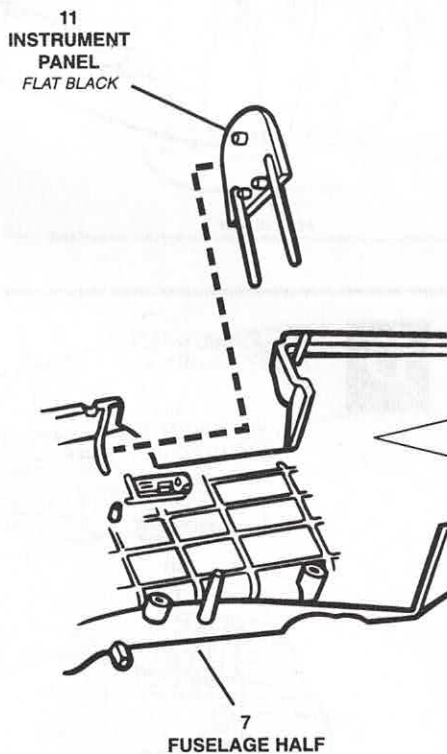

2

FUSELAGE ASSEMBLY

A

7
FUSELAGE HALF

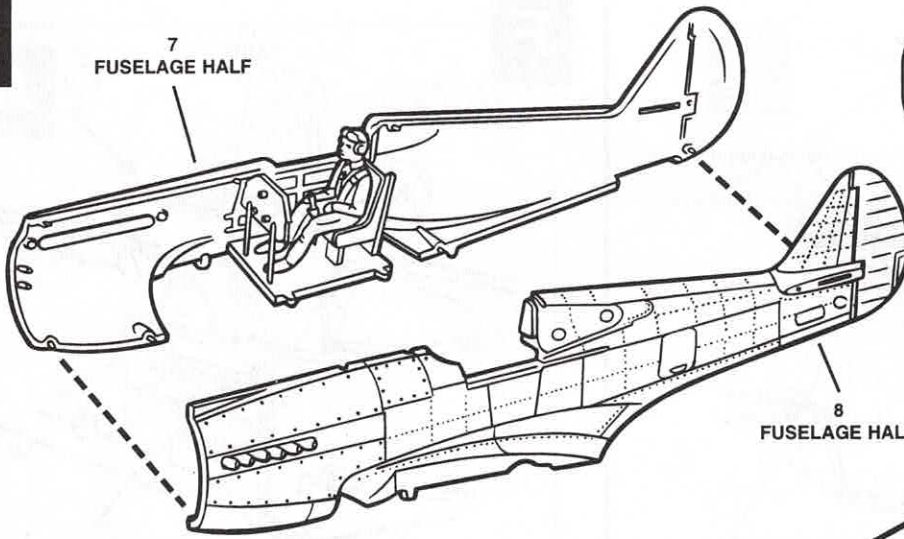

Helpful Hint

You can use a rubberband to hold pieces together while the glue is drying.

8
FUSELAGE HALF

16
MACHINE GUN HALF

15
MACHINE GUN HALF

B

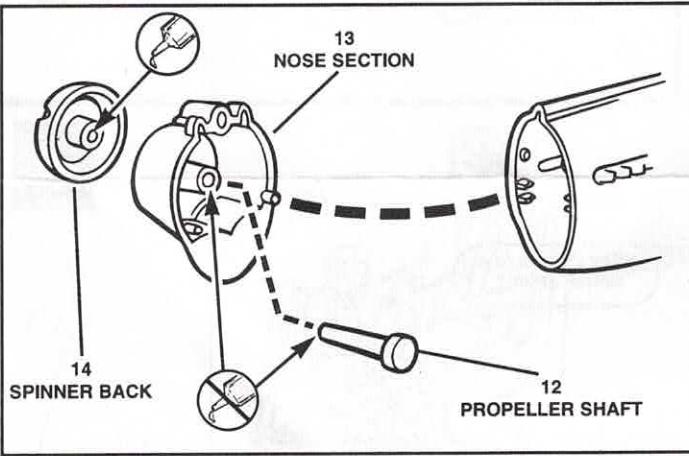

13
NOSE SECTION

14
SPINNER BACK

12
PROPELLER SHAFT

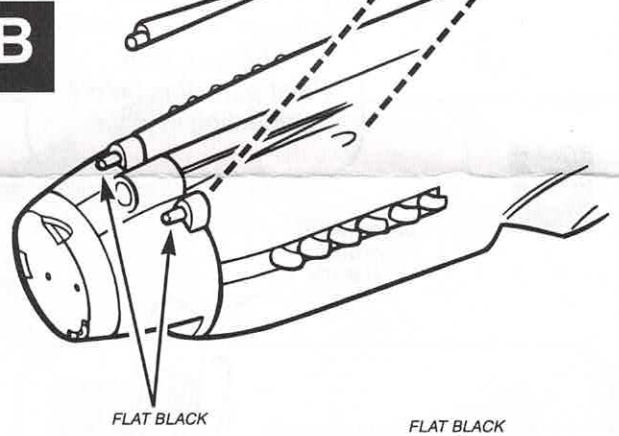

FLAT BLACK

FLAT BLACK

C

17
RIGHT STABILIZER

18
LEFT STABILIZER

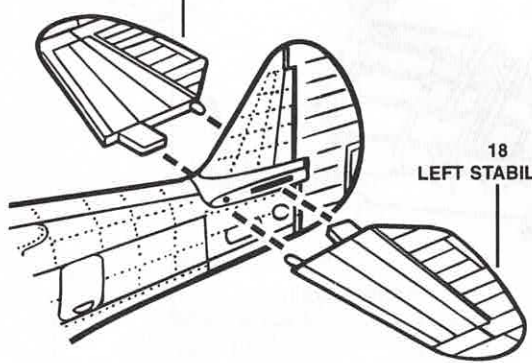

D

19
TAIL WHEEL
ALUMINUM

20
TAIL WHEEL DOORS
CHROMATE GREEN-PRIMER

21
RETAINER

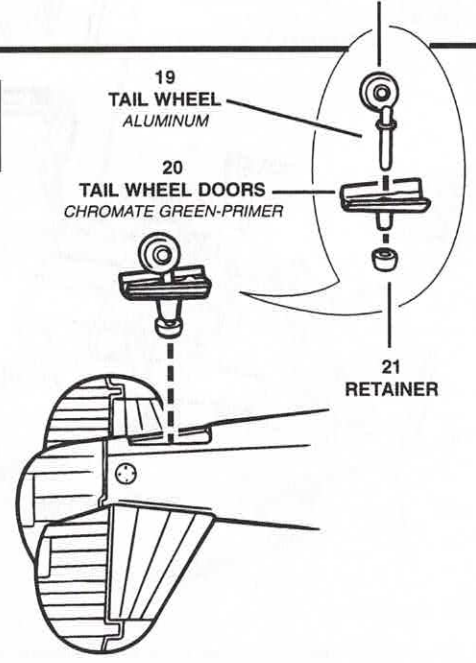

3

WING ASSEMBLY

A

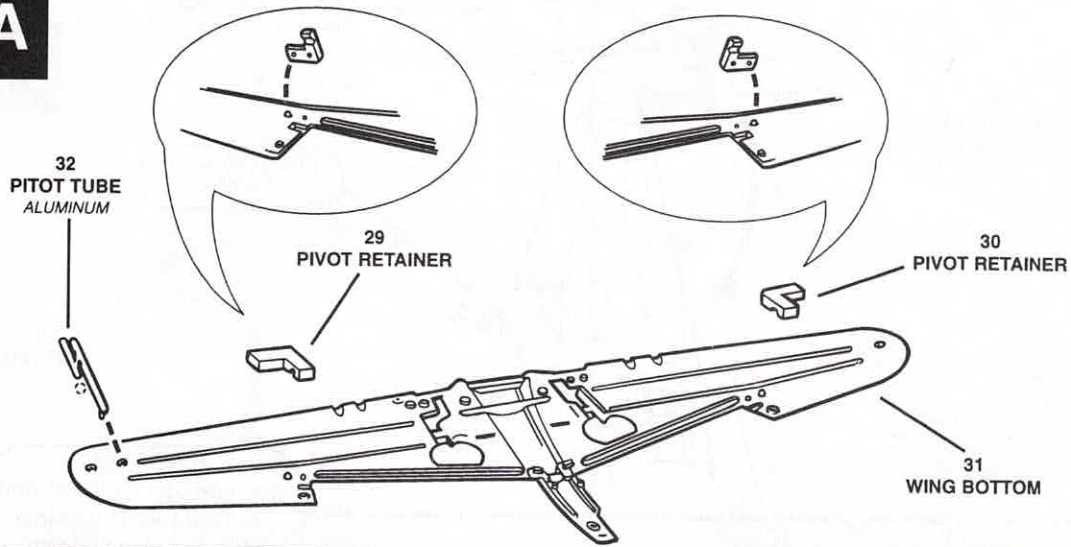

B

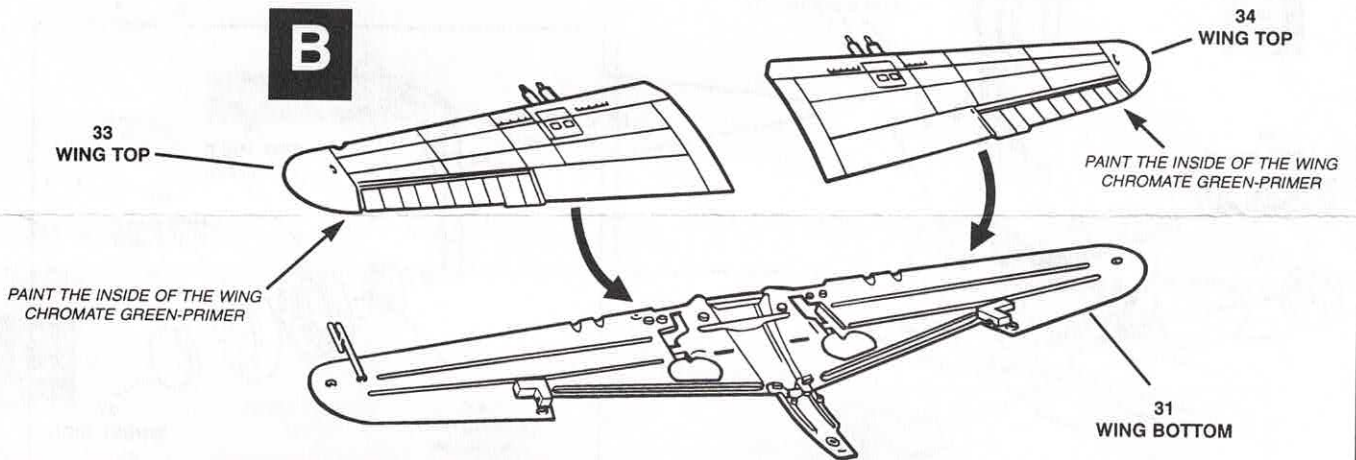

C

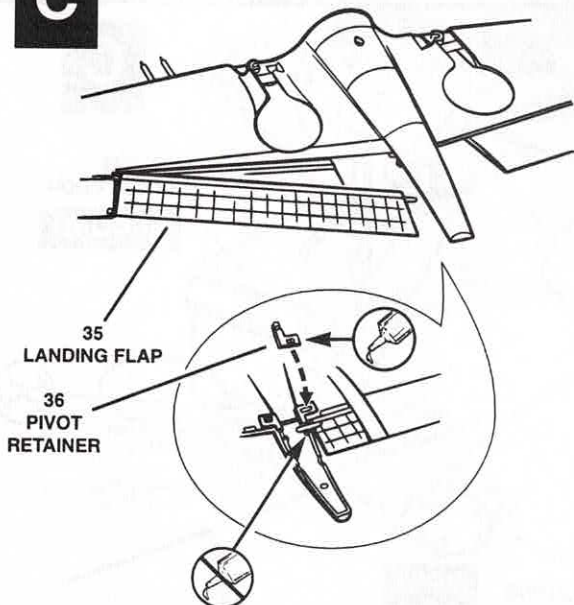

D

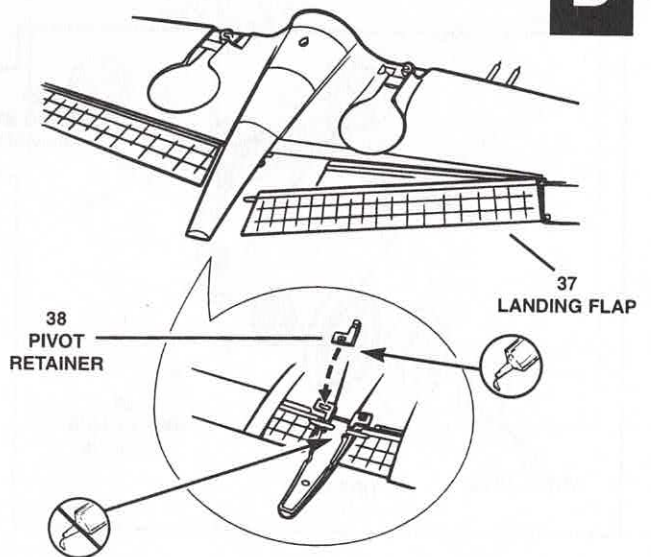

4

LANDING GEAR ASSEMBLY

A

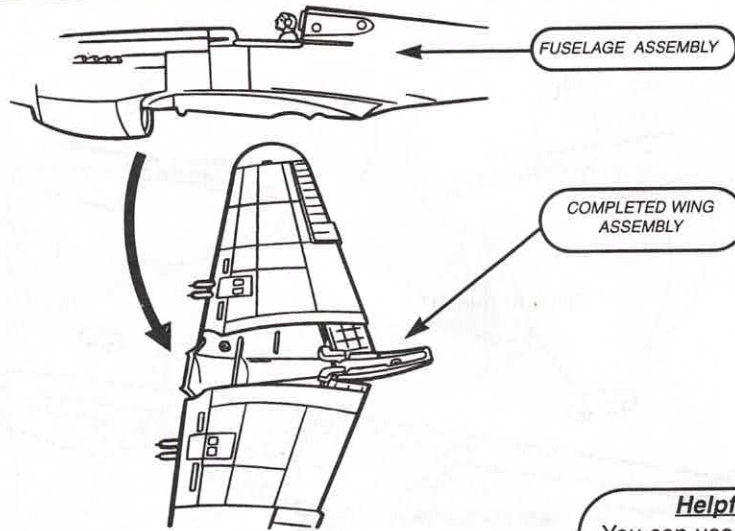

Helpful Hint

You can use a rubberband to hold pieces together while the glue is drying.

B

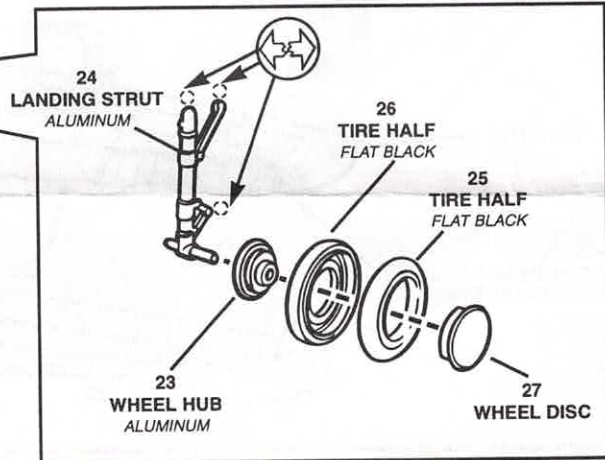
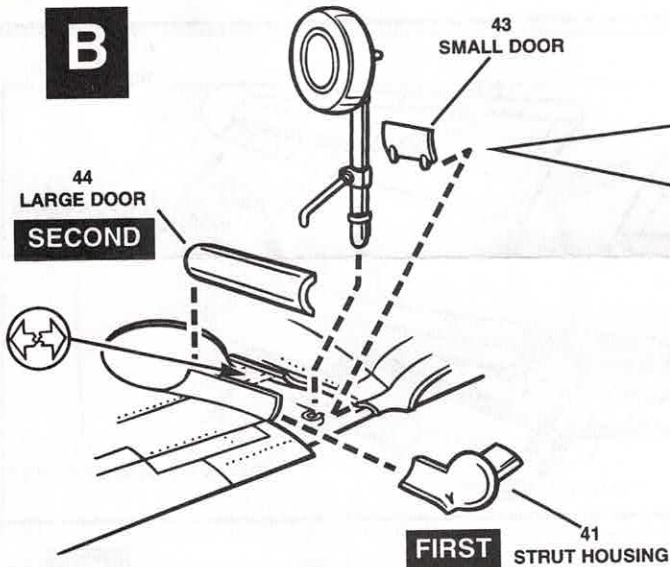

C

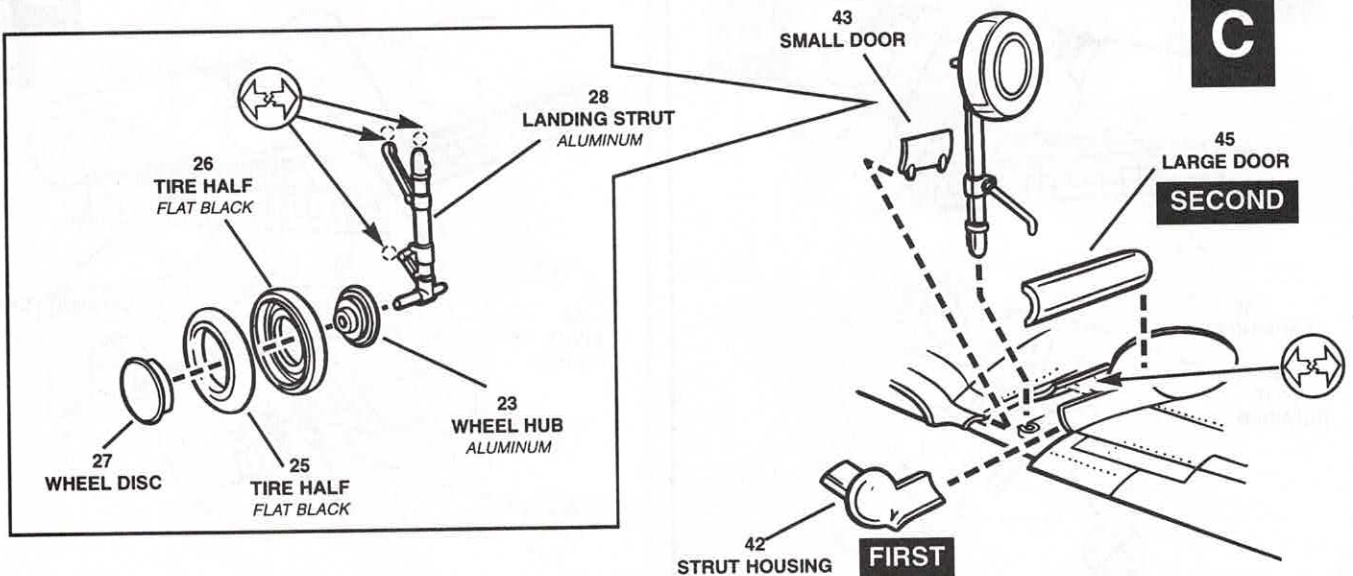

5

FINAL ASSEMBLY

A

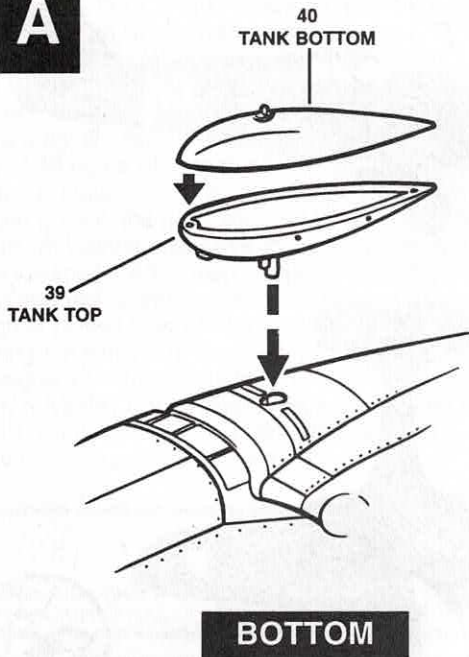

B

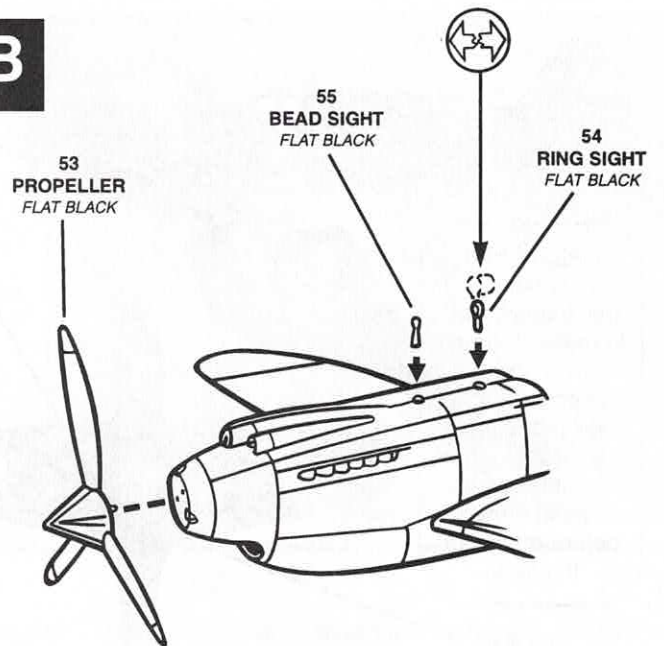

Helpful Hint

If you get glue on the windshield, do not try to wipe it off. Let the glue dry or it will smear.

C

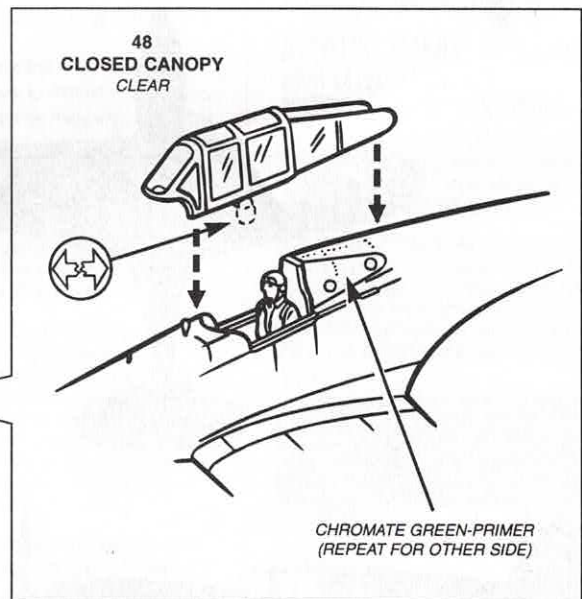
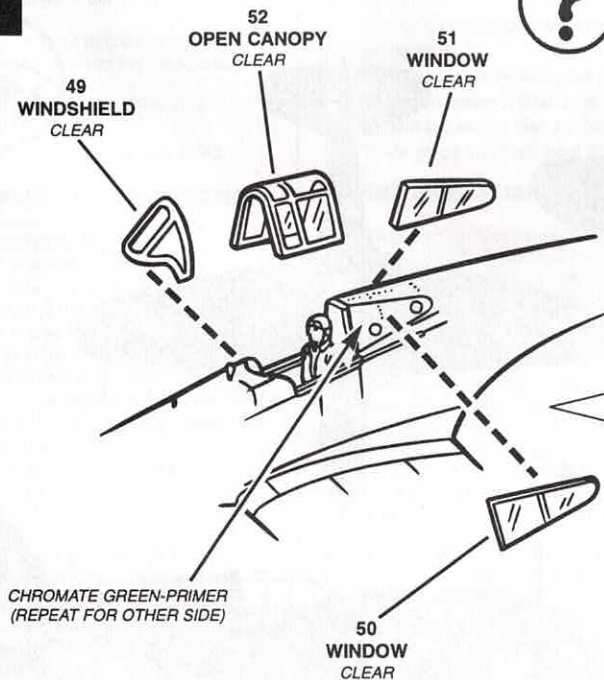

DECAL PLACEMENT

FOR ADDITIONAL HELP PLACING THE DECALS, SEE THE BOX TOP.

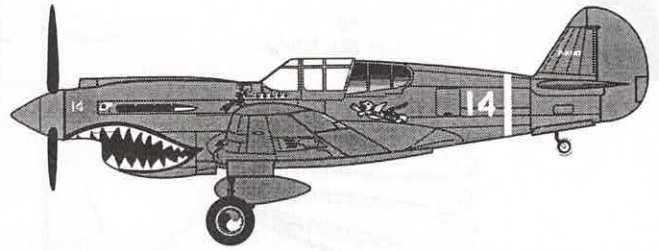
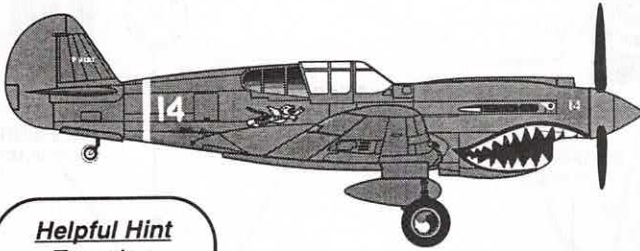

Helpful Hint
 Try using transparent tape to mask off areas that need to be painted, this will produce a crisp, clean edge. Wait until the paint dries before removing the tape.

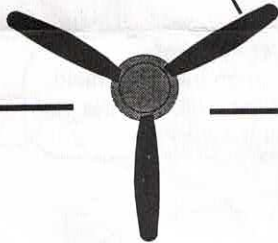
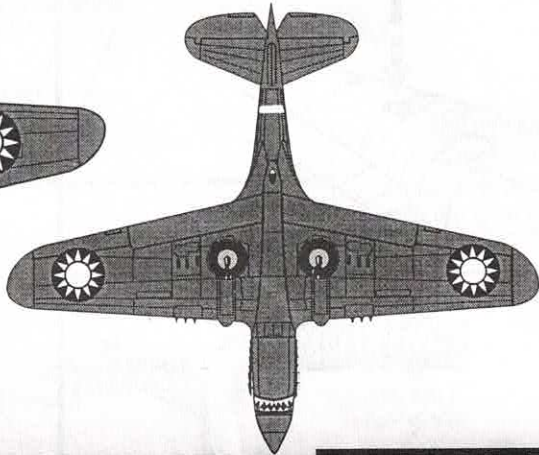
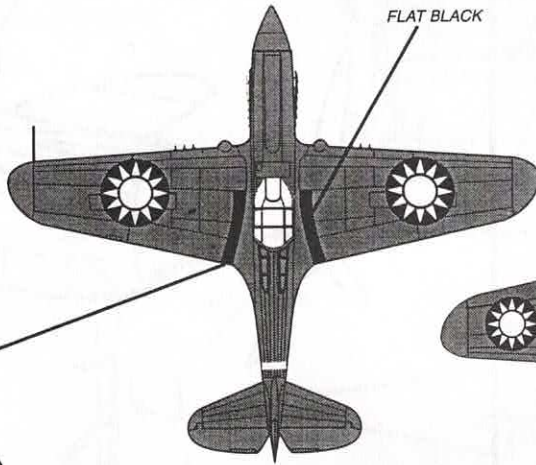

FLAT BLACK

FLYING TIGERS

U.S. ARMY

