

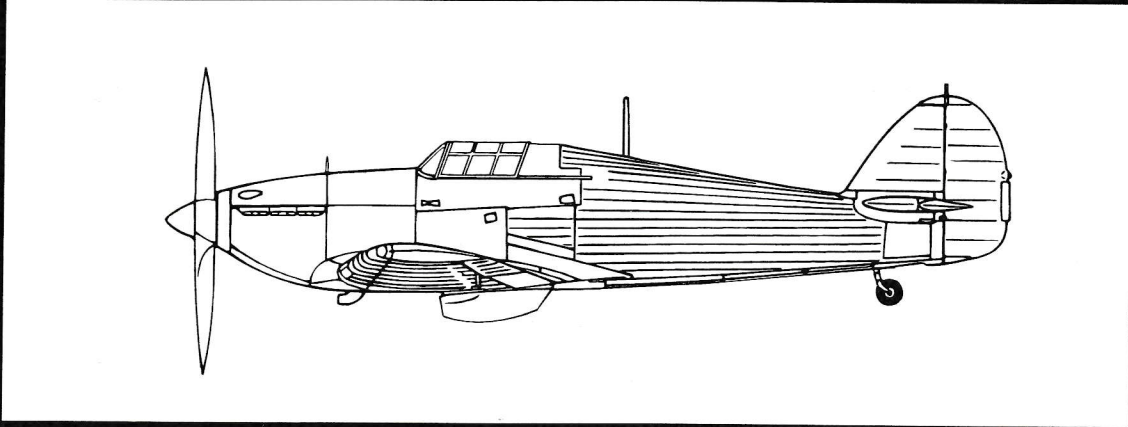

# Classic Airframes



## Hawker Hurricane Mk. I

First flown in November 1935, the Hawker Hurricane requires no introduction. Together with the Supermarine Spitfire, the two aircraft spearheaded the British aircraft industry into the forefront of "Modern Fighter" development. This kit presents for the first time in 1/48th scale the earliest operational version of this aircraft, distinctive because of its fabric covered wings.

As well as serving with the RAF, the aircraft immediately caught the eye of foreign governments looking for modern fighters and it was exported to Belgium, Finland, Yugoslavia, Turkey, Rumania, South Africa. It was also ordered by Poland, but they never arrived.

The Hurricane's original fabric wings were gradually replaced by metal although some aircraft used their original wings well into the Battle of Britain.

Classic Airframes is pleased to offer this variant of this distinguished aircraft. We would like to thank Steven Eisenman and Jim Maas for their cooperation in this project.

### Hurricane Mk. I Specifications

<b>Powerplant:</b>	1,030hp Rolls-Royce Merlin II/III inline	<b>Armament:</b>	8x .303 Machine Guns
<b>Wing Span:</b>	40'		
<b>Length:</b>	31'4"		
<b>Maximum Speed:</b>	317 mph		

This model kit is intended for experienced modelers. The nature of limited-run kits such as this require additional time and effort to clean up and fit the parts, as well as experience with the various media utilized to provide the most accurate effect on the finished model. Use CyA ('super') glue to assemble Resin (PU) parts.

Classic Airframes P.O. Box 577580 Chicago, IL 60657-7580 USA

Assembly Instruction Symbols



Paint Reference Guide

<b>A</b>	Interior Green	FS 34558	<b>C</b>	Aluminum	_____	<b>E</b>	Dark Brown	_____
<b>B</b>	Flat Black-grey	_____	<b>D</b>	Rusty Brown	_____	<b>F</b>	Gunmetal	_____

Parts

PLASTIC PARTS

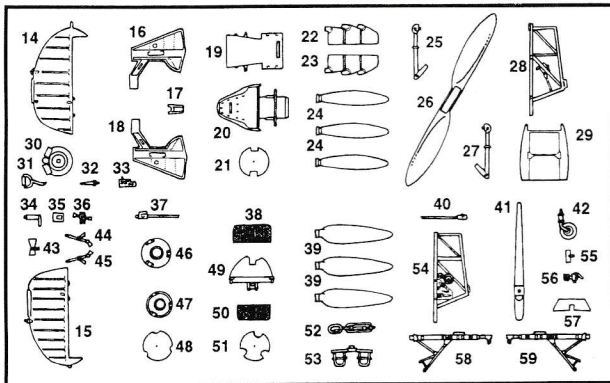
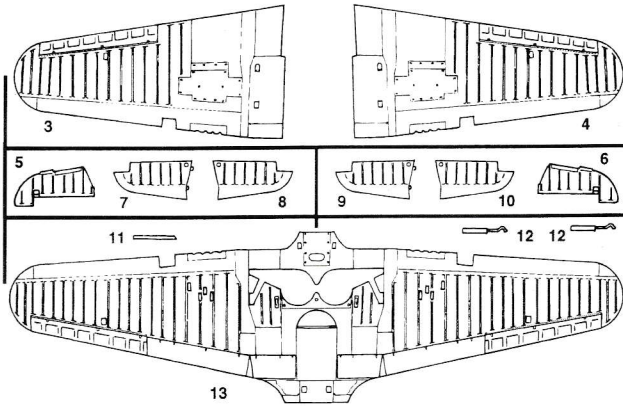
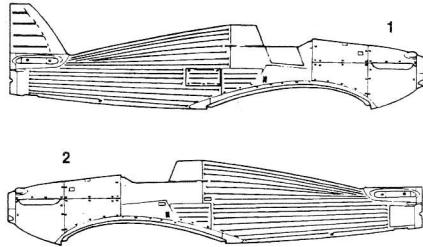

PLEASE NOTE

Parts are included in this kit to build one of three variants of the Hurricane Mk.I. Variations include propeller, exhausts, ventral strake, canopy and venturi. Check your references for the aircraft you are modeling to create an accurate model.

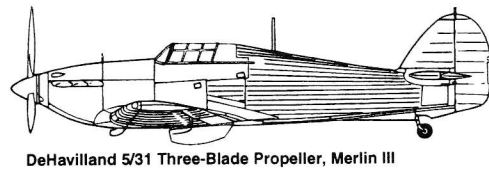
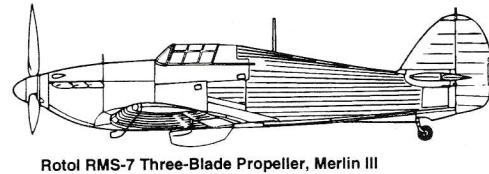
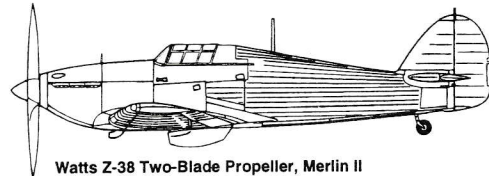

CLEAR PARTS

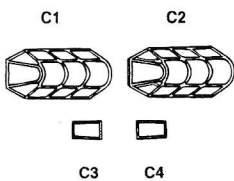

RESIN PARTS

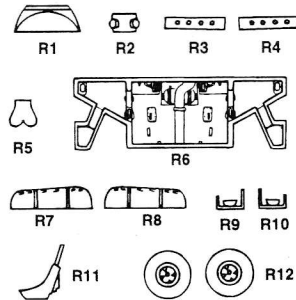

1

Instrument panel is Satin Black with Black gauges and Silver details

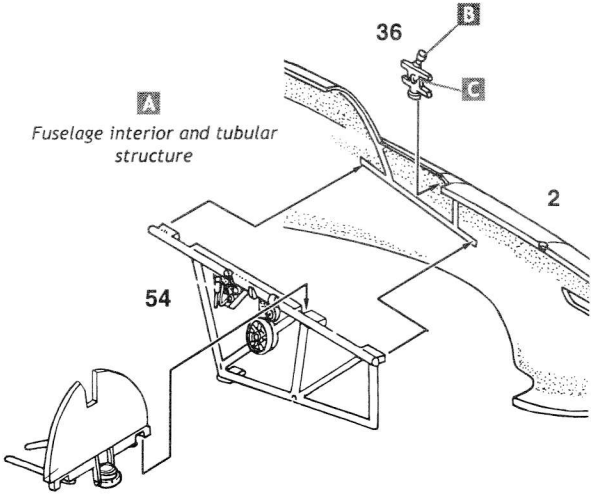
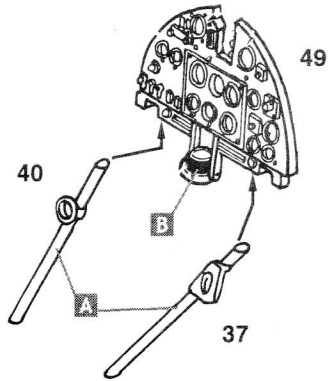

2

All cockpit parts

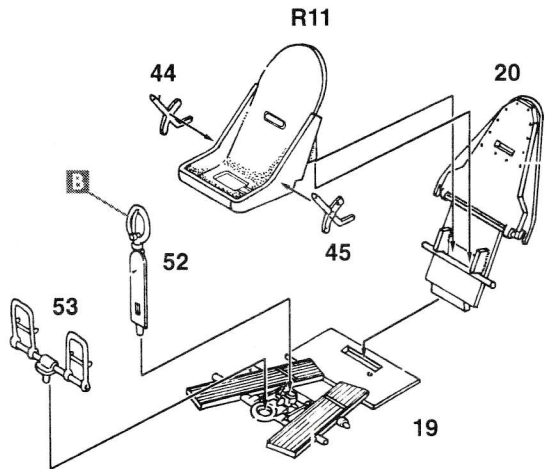

3

Fuselage interior and tubular structure

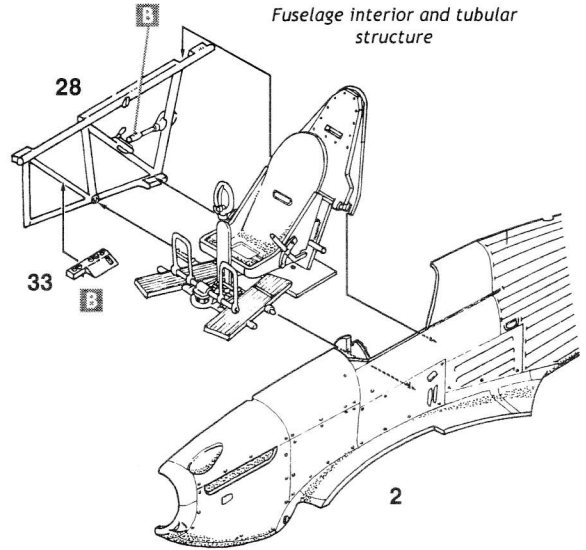

4

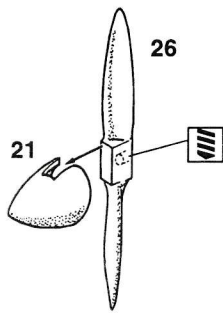

**Watts Z-38  
Propeller**

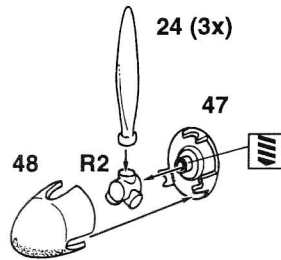

**DeHavilland 5/31  
Propeller**

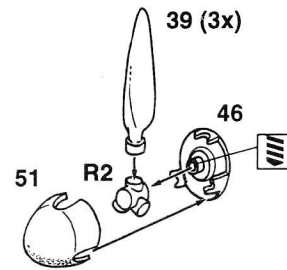

**Rotol RMS-7  
Propeller**

*Consult your references for propeller blade and spinner colors. Propeller may be installed after all other assembly steps are complete.*

5

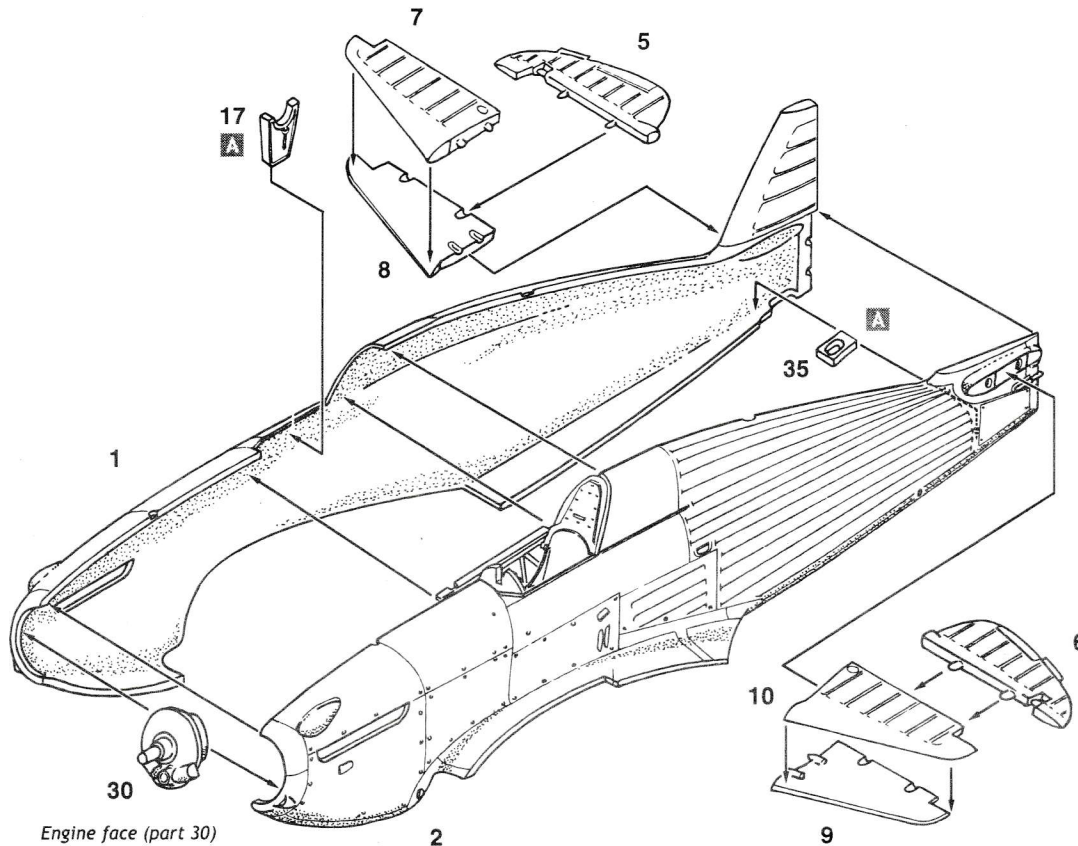

Engine face (part 30)  
is Dark Grey

6



NOTE

The wheel well part R6 has been resin-cast to capture greater detail. Due to molding limitations, this entailed a large pour stub that must be removed. This is illustrated above by the dashed area. Carefully cut and sand this area away and dry-fit and trim to fit between parts 3/4 and 13.



OPTIONS

Gun ports R3 and R4 are optional. You must remove the appropriate sections of the wing leading edge to fit.

Landing light assemblies R9/C3 and R10/C4 are optional. You must remove the appropriate sections of the wing leading edge to fit.

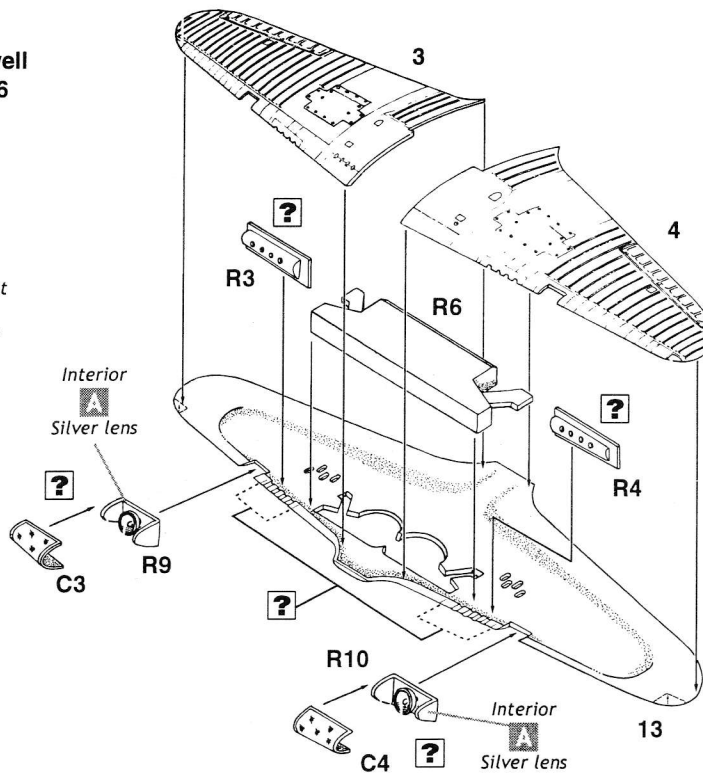

7

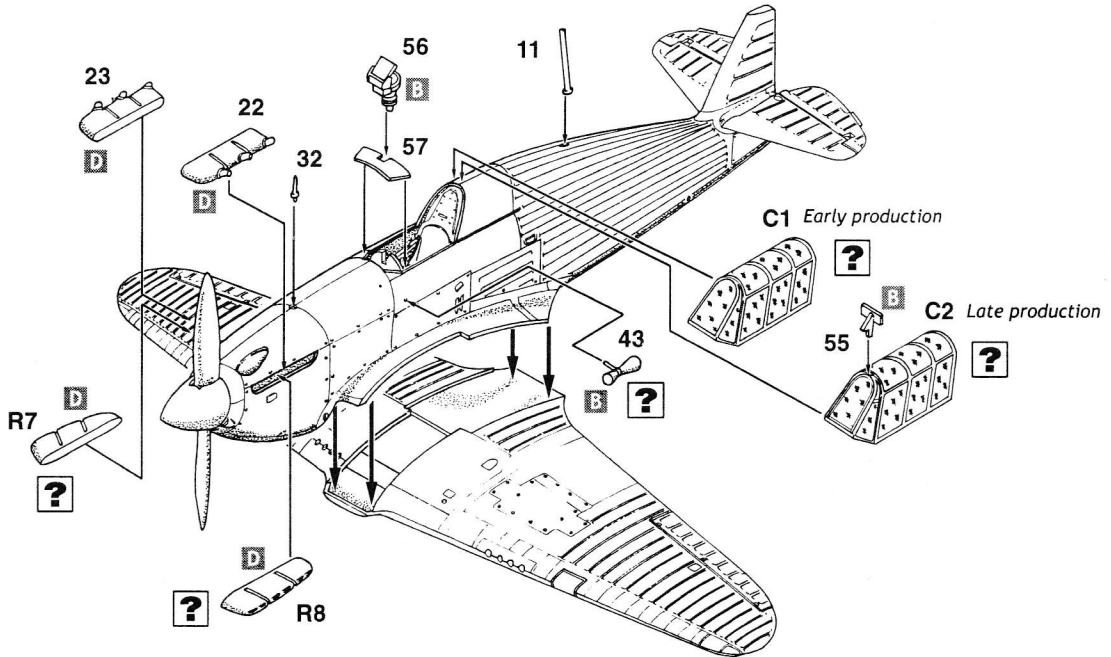

8

Interior of radiator

Interior of wheel wells

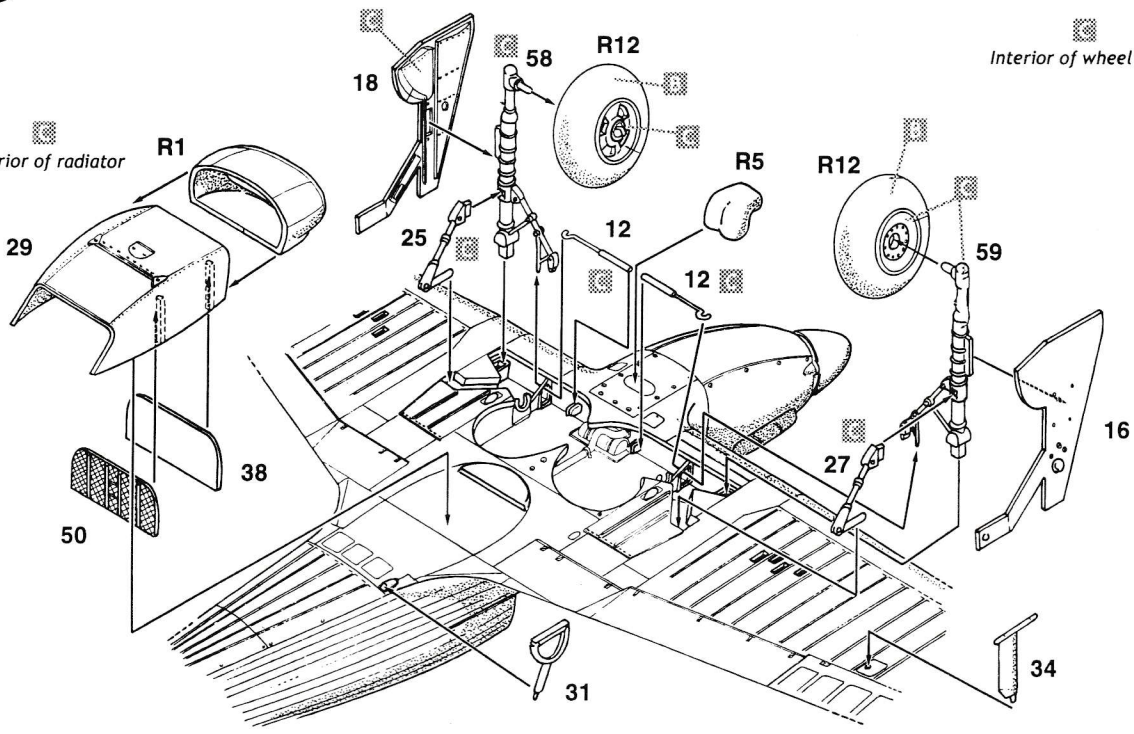

9



Early production machines lacked the ventral strake (part 41) and had a shorter rudder (part 15). Check references for the aircraft you are modeling.

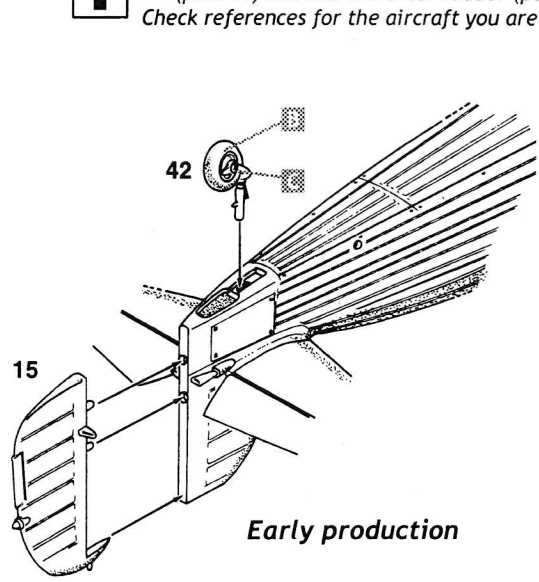

Early production

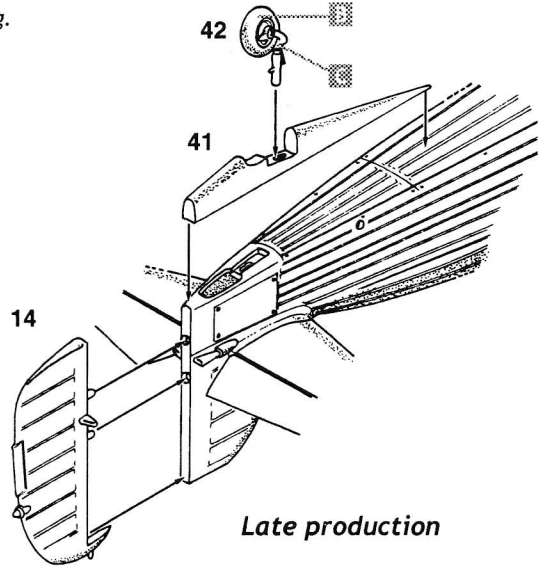

Late production

# HAWKEL HUI IICALIE MK.1 PAINTING & MARKING GUIDE

Pilot Vojislav Rakić, 52 Group, 2nd Regiment Yugoslav Air Force, 1941

3-blade DeHavilland Propeller

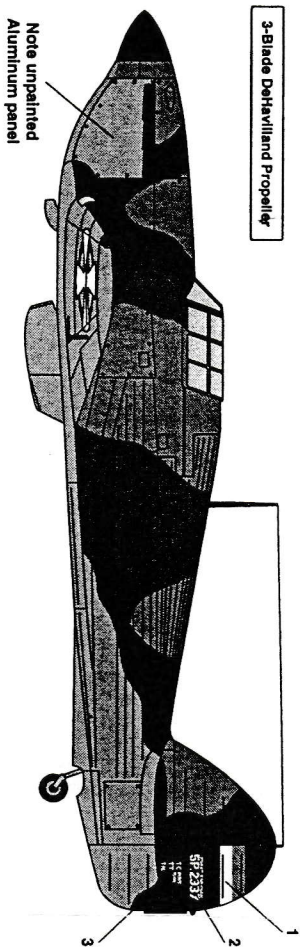

Note unpainted Aluminum panel

- Dark Brown FS 30108
- Ochre FS 30371
- Dark Green FS 34087
- Light Blue-Gray FS 25526

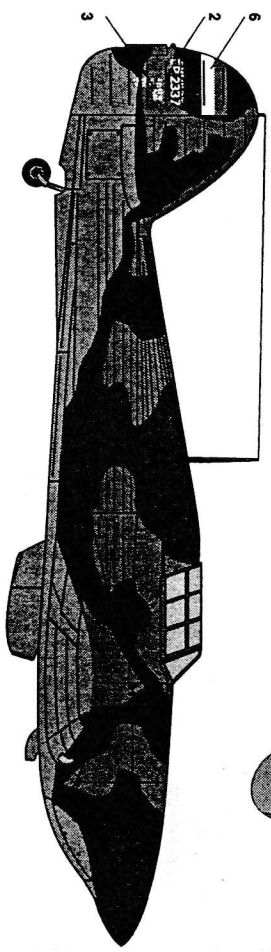
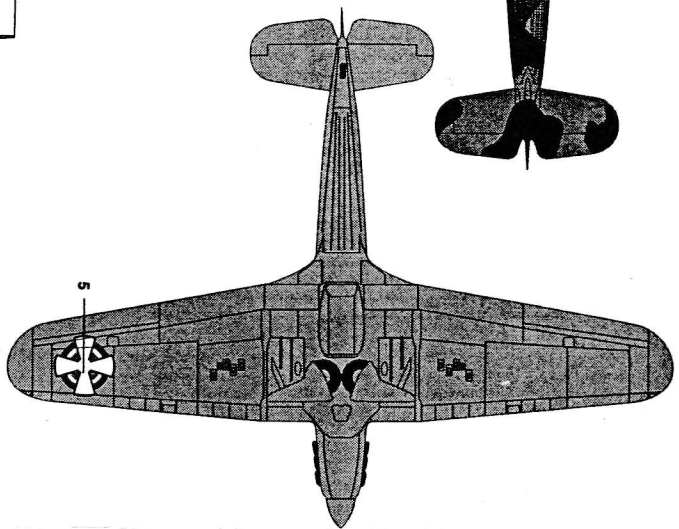
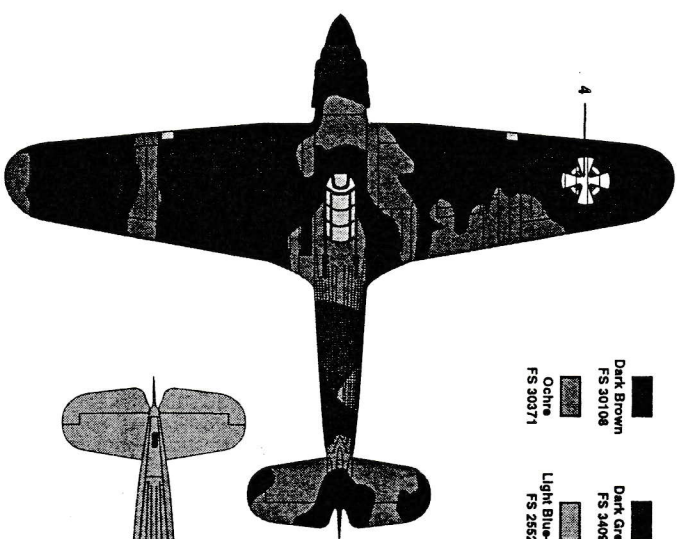

Two-bladed Watts Propeller

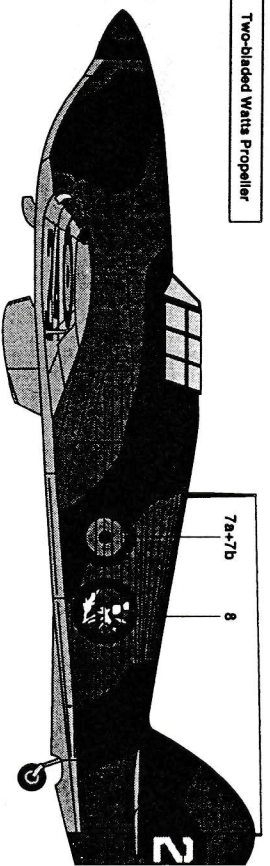

- RAF Dark Green FS 34079
- RAF Dark Earth FS 30118
- Aluminum

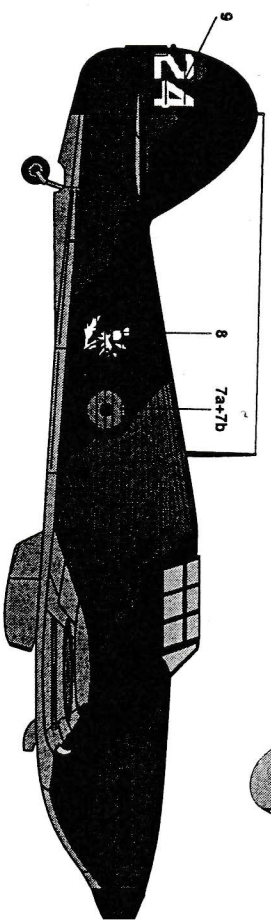
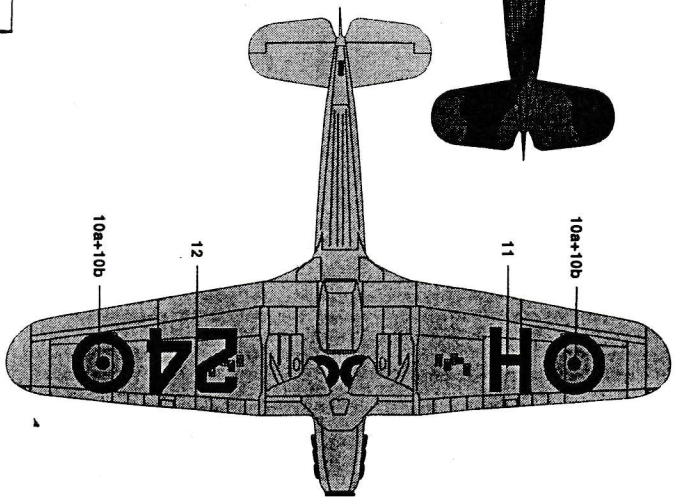

# HAWKEI HUI IICALIE MK.1 PAINTING & MARKING GUIDE

2nd Escadrille, 1st Group, 2nd Regiment de Chasse, Aviation Belge Militaire, Diest, 1924

7a+7b

8

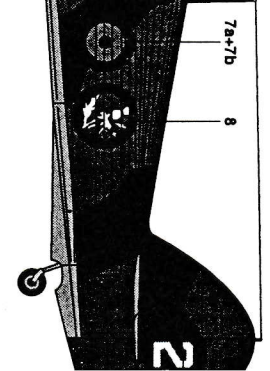

- 10a+10b
- 11
- 12

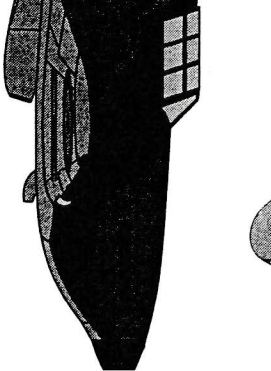
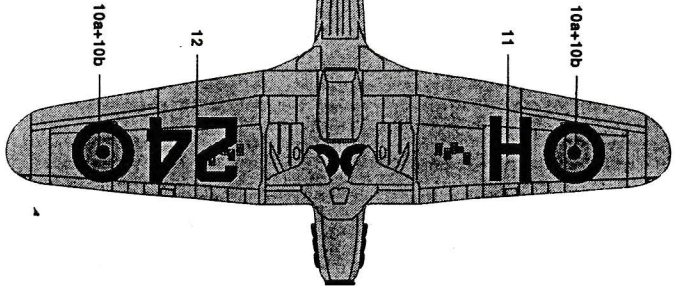
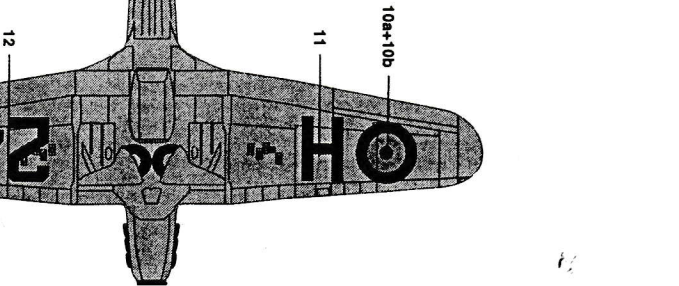

# Hawker Hurricane Mk. I

Ex-Yugoslav Air Force, captured by the...

3-Blade DeHavilland Propeller

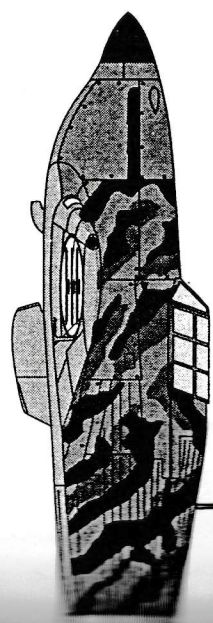

13

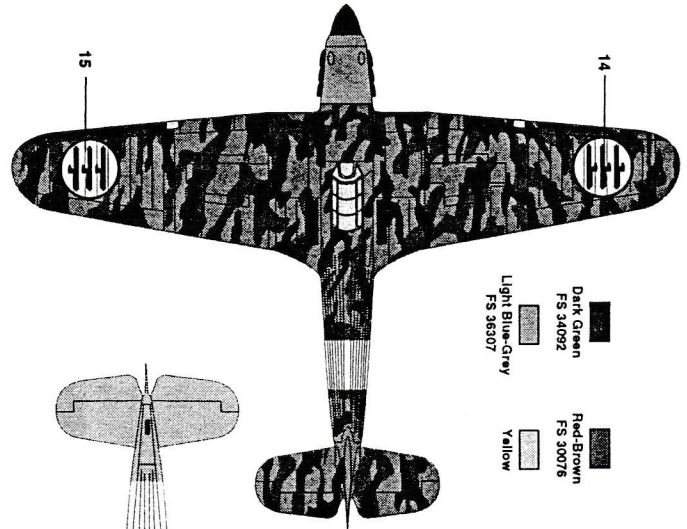

14

15

- Dark Green FS 34092
- Red-Brown FS 30076
- Light Blue-Grey FS 36907
- Yellow
- Black
- White
- Blue
- Red
- Green
- Brown
- Grey
- Orange
- Purple
- Pink
- Light Green
- Light Blue
- Light Yellow
- Light Grey
- Light Brown
- Light Orange
- Light Purple
- Light Pink
- Light Light Green
- Light Light Blue
- Light Light Yellow
- Light Light Grey
- Light Light Brown
- Light Light Orange
- Light Light Purple
- Light Light Pink
- Light Light Light Green
- Light Light Light Blue
- Light Light Light Yellow
- Light Light Light Grey
- Light Light Light Brown
- Light Light Light Orange
- Light Light Light Purple
- Light Light Light Pink

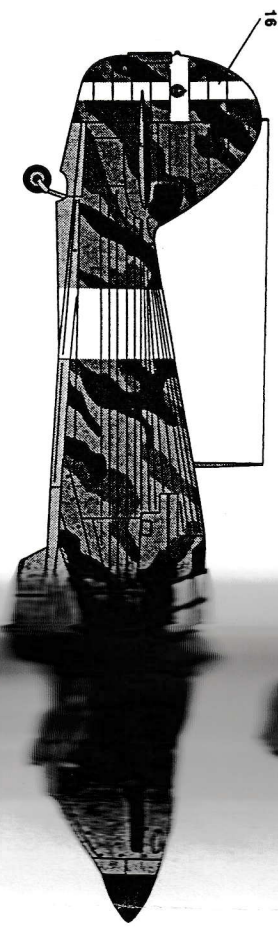
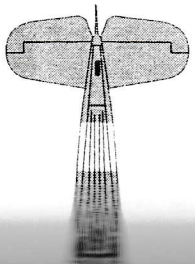

16

# PAINTING & MARKING GUIDE

# Hawker Hurricane Mk. I

and markings for the Ex-Yugoslav Air Force, captured by the...

Two-bladed Propeller



13

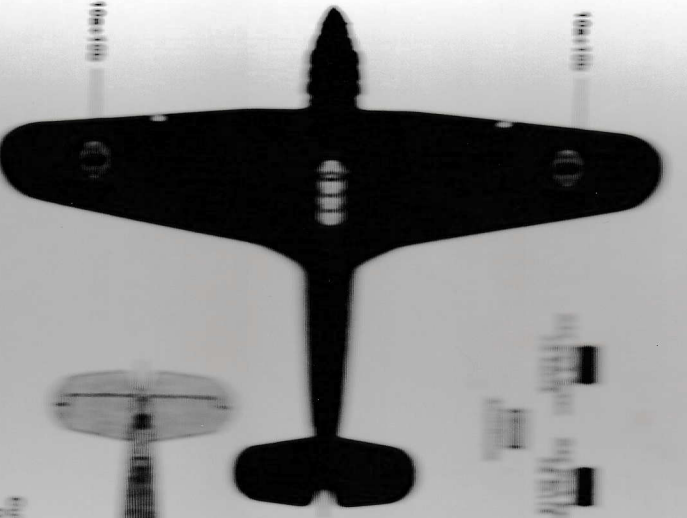

14

15

- Dark Green FS 34092
- Red-Brown FS 30076
- Light Blue-Grey FS 36907
- Yellow
- Black
- White
- Blue
- Red
- Green
- Brown
- Grey
- Orange
- Purple
- Pink
- Light Green
- Light Blue
- Light Yellow
- Light Grey
- Light Brown
- Light Orange
- Light Purple
- Light Pink



23

21

# PAINTING & MARKING GUIDE

and markings for the Ex-Yugoslav Air Force, captured by the...

Two-bladed Propeller



13



14

15

- Dark Green FS 34092
- Red-Brown FS 30076
- Light Blue-Grey FS 36907
- Yellow
- Black
- White
- Blue
- Red
- Green
- Brown
- Grey
- Orange
- Purple
- Pink
- Light Green
- Light Blue
- Light Yellow
- Light Grey
- Light Brown
- Light Orange
- Light Purple
- Light Pink

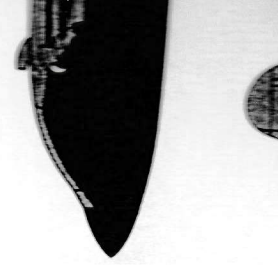
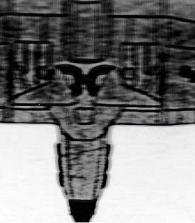

23

21



# Hawker Hurricane Mk. I

PAINTING & MARKING GUIDE

LeLv 32, Finnish Air Force, 1941

3-Blade DeHavilland Propeller

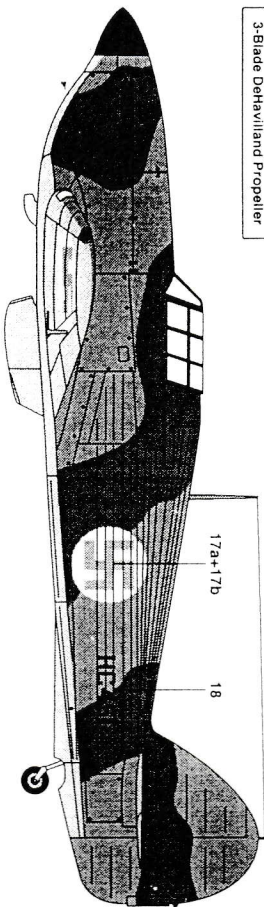

# Hawker Hurricane Mk. I

PAINTING & MARKING GUIDE

LeLv 32, Finnish Air Force, 1941 (Continuation War paint scheme)

3-Blade DeHavilland Propeller

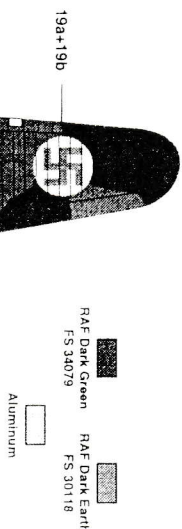
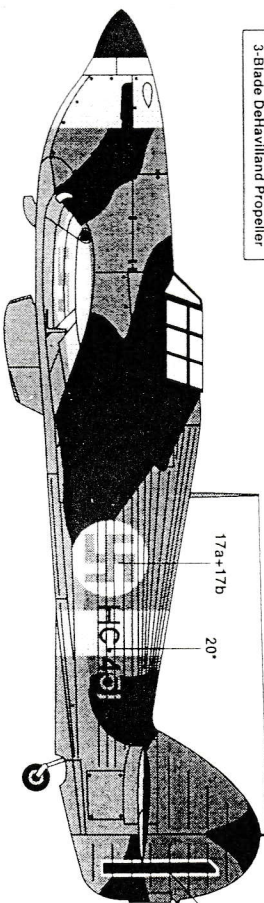

NOTE  
 Hurricans were originally alloted serial numbers with 'HU' prefixes. This was later changed to 'HC'. Both styles are provided.  
 RAF Dark Green FS 34073  
 RAF Dark Earth FS 30118  
 Aluminum

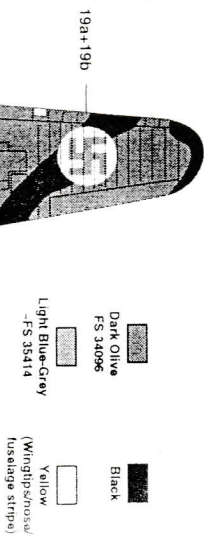
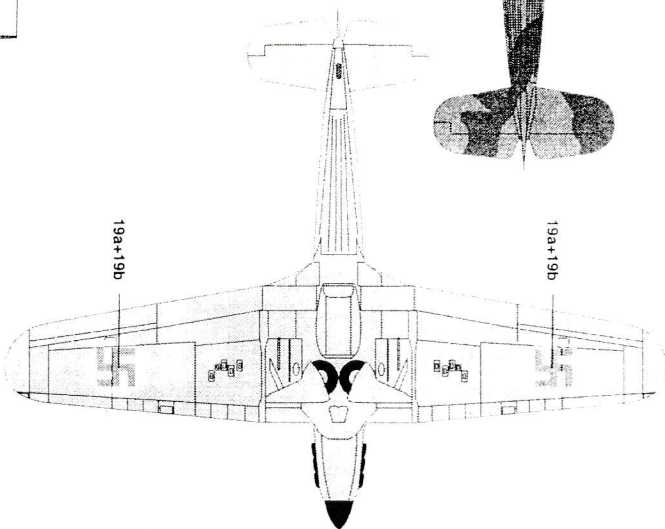
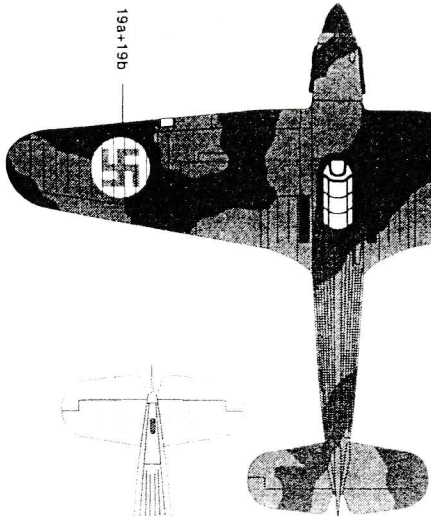

NOTE  
 Green serial numbers are provided for your use as indicated in the illustrations.  
 Dark Olive FS 34096  
 Light Blue-Grey FS 35414  
 Black  
 Yellow (Wingtips/nose fuselage stripe)

