

# 18 Hawker Tempest F.2

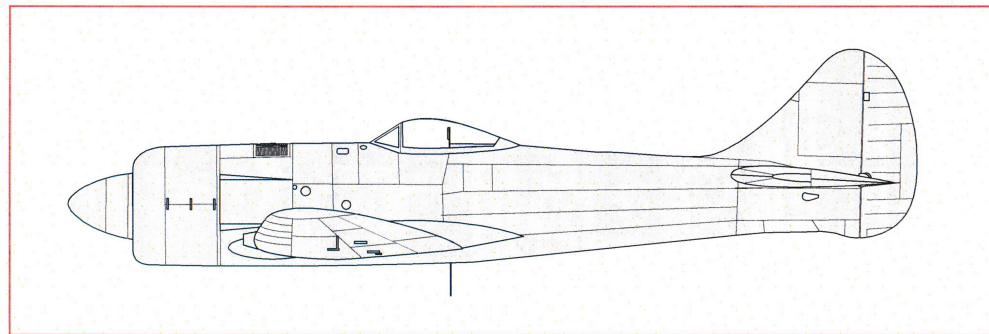
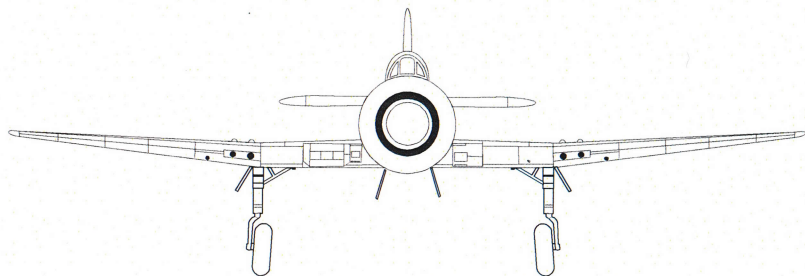
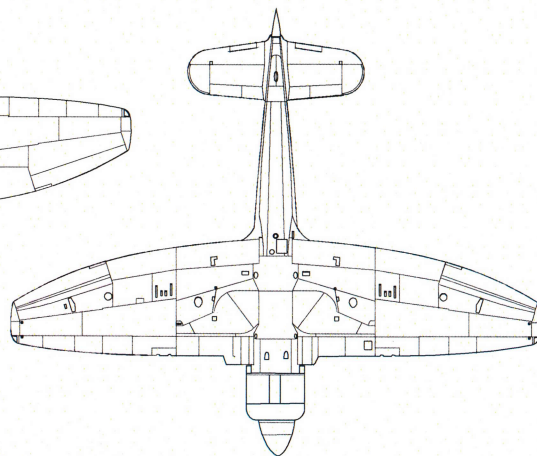
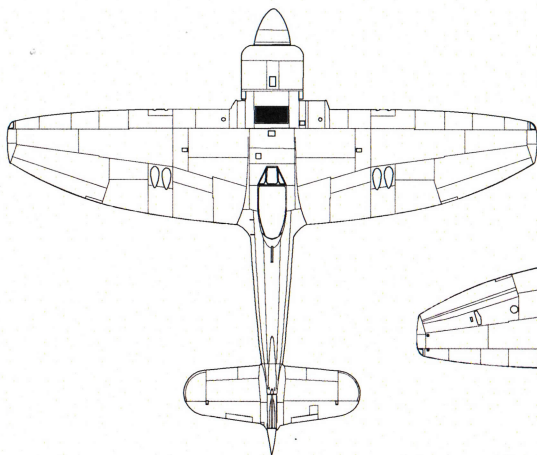
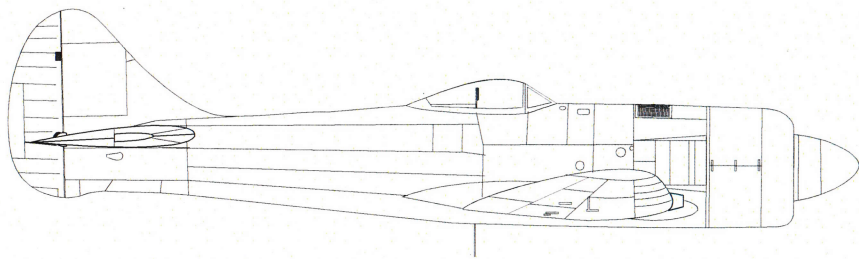
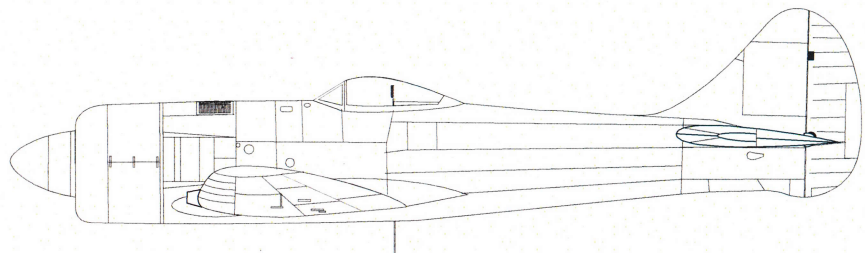

## Hawker Tempest Mk II/F.2

### Historie

Hawker Tempest (v angličtině bouře) byl velmi výkonným britským jednomotorovým stíhacím letounem druhé světové války. První sériový Tempest Mk.V (JN729) byl zalétán 21. června 1943. Již od počátku výroby byly Mk.V vybaveny kapkovitým krytem kabiny a čtyřadvacetiválcovým řadovým motorem Napier Sabre IIA o vzletovém výkonu 1603 kW. Prvních sto kusů Mk.V Series 1 bylo vyzbrojeno čtveřicí kanónů British Hispano Mk.II instalovaných v křídle, jejichž hlavně o 0,2 m přesahovaly náběžnou hranu. Další Tempesty Mk.V Series 2 obdržely kanóny Hispano Mk.V s kratší hlavní. Tempesty byly poprvé bojově nasazeny začátkem května 1944 nad Francií při útocích na dopravní systém a letiště. Letadla Tempest aspirovala díky své rychlosti i ostatním vlastnostem na titul nejlepší stíhačky Royal Air Force.

Další sériově vyráběnou verzí Tempestu se stala verze Mk.II s hvězdicovým motorem Centaurus. První ze dvou prototypů Tempest II vzletl v červnu 1943 následován druhým prototypem v září. Celkem bylo vyrobeno 457 kusů verze Mk.II/F.2.

### History

The Hawker Tempest was a very powerful British single-engine fighter aircraft of World War II. The first serial Tempest Mk.V (JN729) was flown on June 21, 1943. From the beginning of production, the Mk.V were equipped with a teardrop-shaped cabin cover and a twenty-four-cylinder inline engine Napier Sabre IIA with a takeoff power of 1603 kW. The first hundred pieces of the Mk.V Series 1 were armed with four British Hispano Mk.II cannons installed in the wing, whose barrel by 0.2 m exceeded the leading edge. Other Tempesty Mk.V Series 2 received Hispano Mk.V cannons with a shorter barrel. Tempests were first deployed in combat in early May 1944 over France during attacks on the transport system and airports. Thanks to its speed and other characteristics, Tempest aircraft aspired to the title of the best Royal Air Force fighter.

Another mass-produced version of the Tempest became the Mk.II version with a Centaurus star engine. The first of two Tempest II prototypes took off in June 1943, followed by a second prototype in September. A total of 457 pieces of the Mk.II / F.2 version were produced.

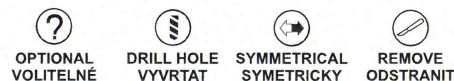

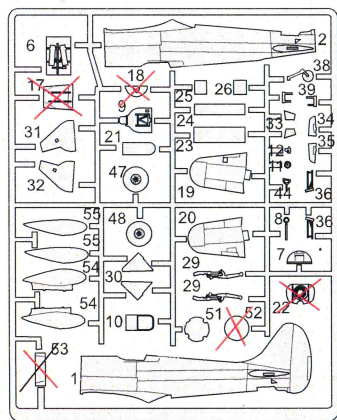

Plastikové díly/  
Plastic parts

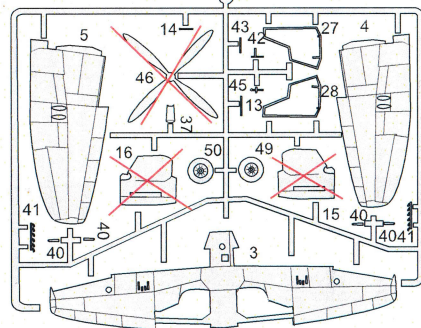

Průhledné díly/  
Clear parts

- C1
- C2
- C3
- C4

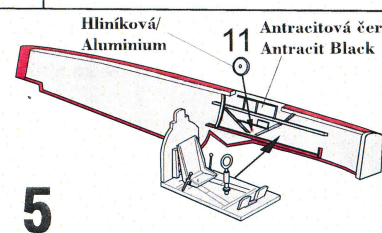
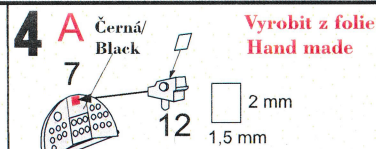
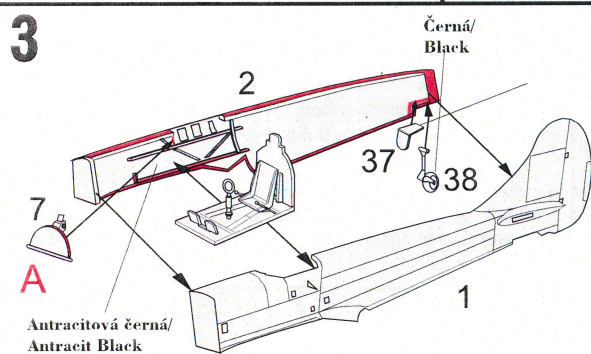
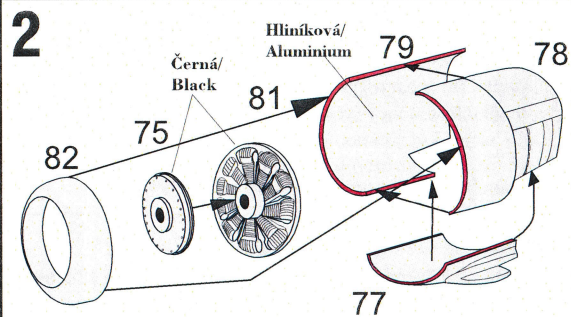
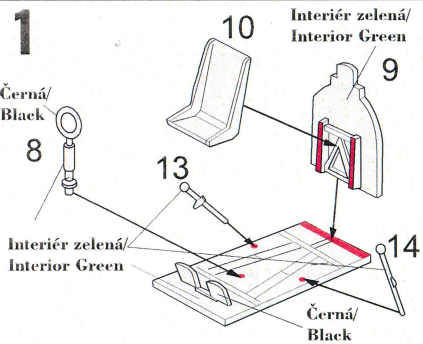
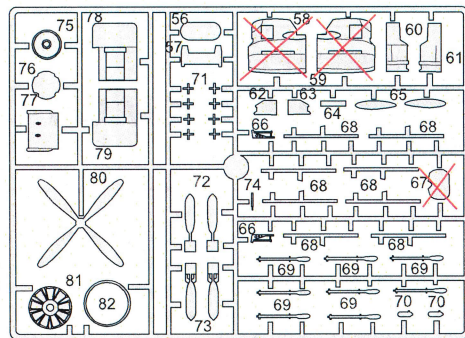

6

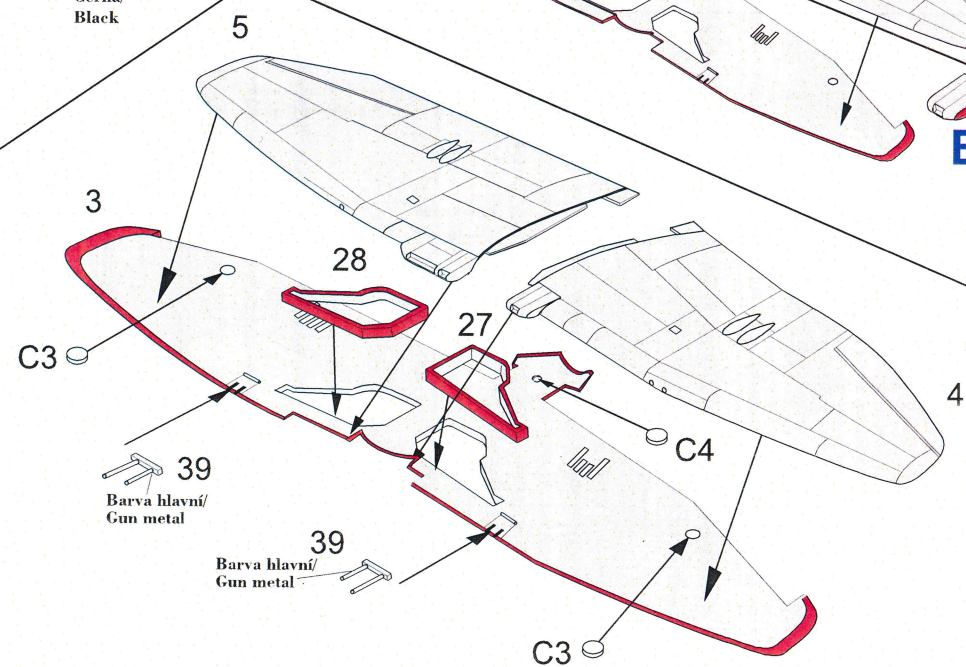
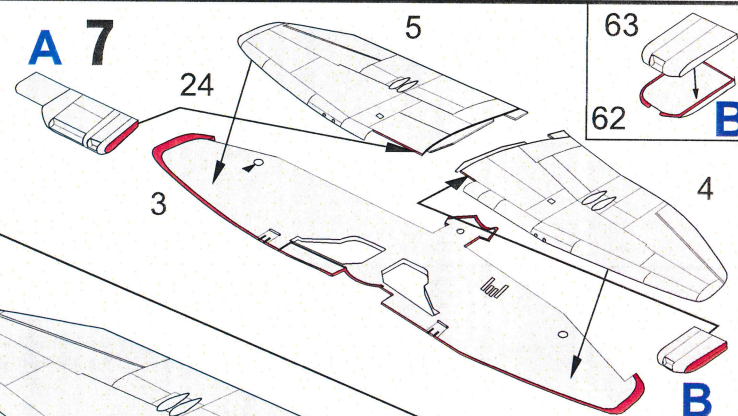
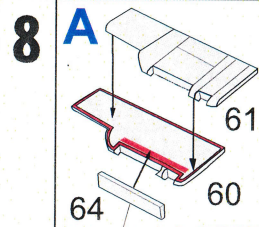
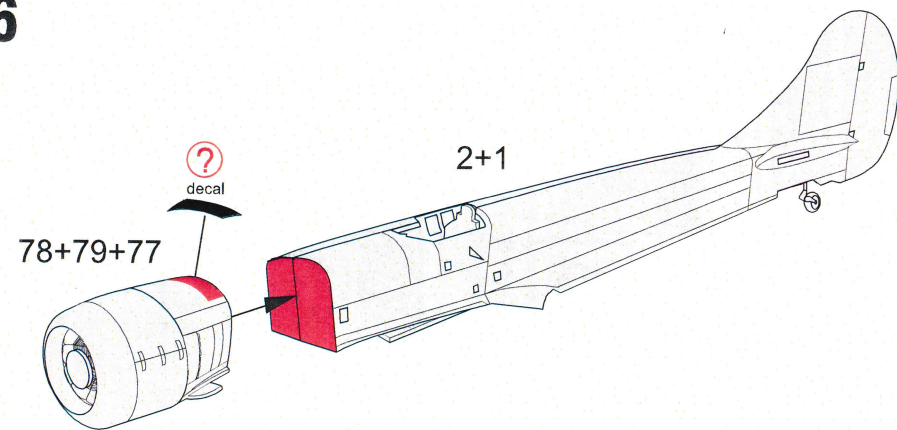

9

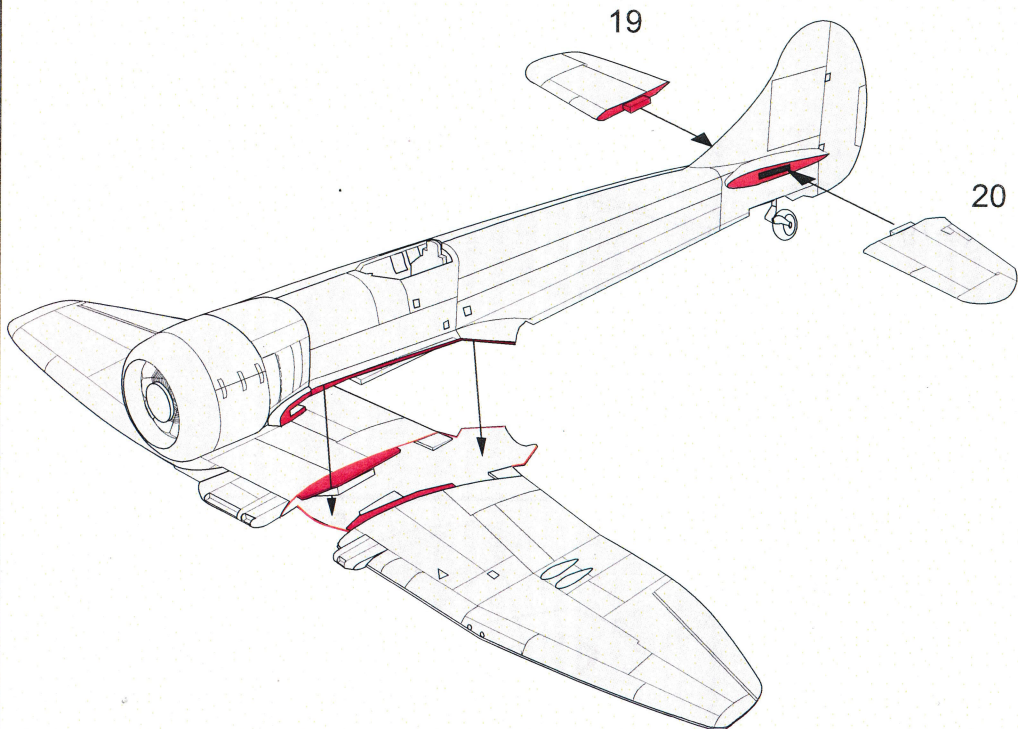

10

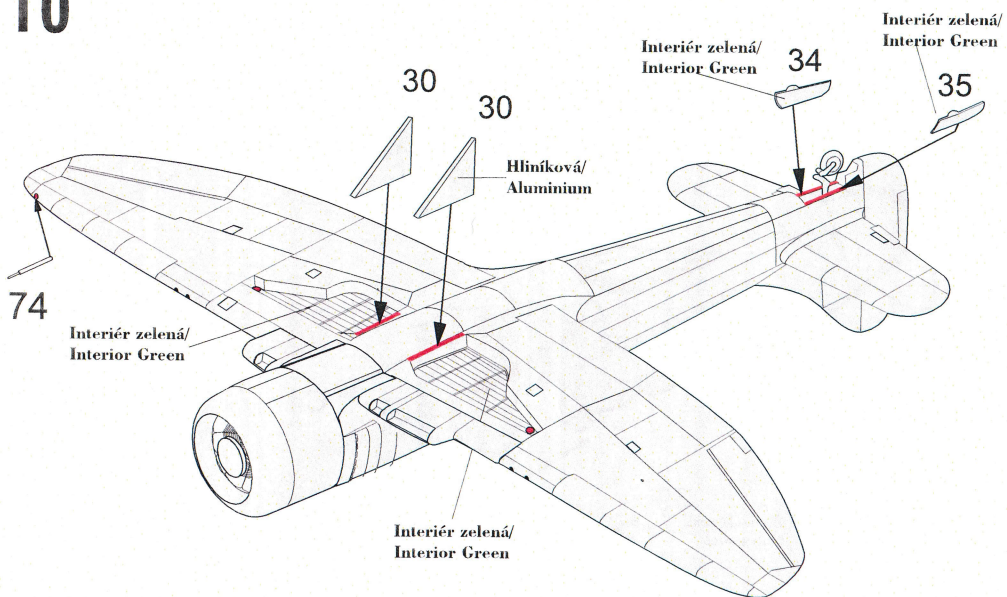

11

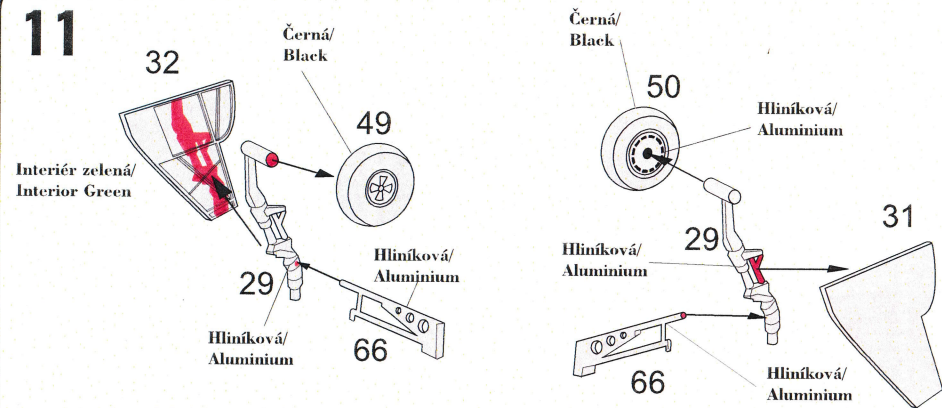

12

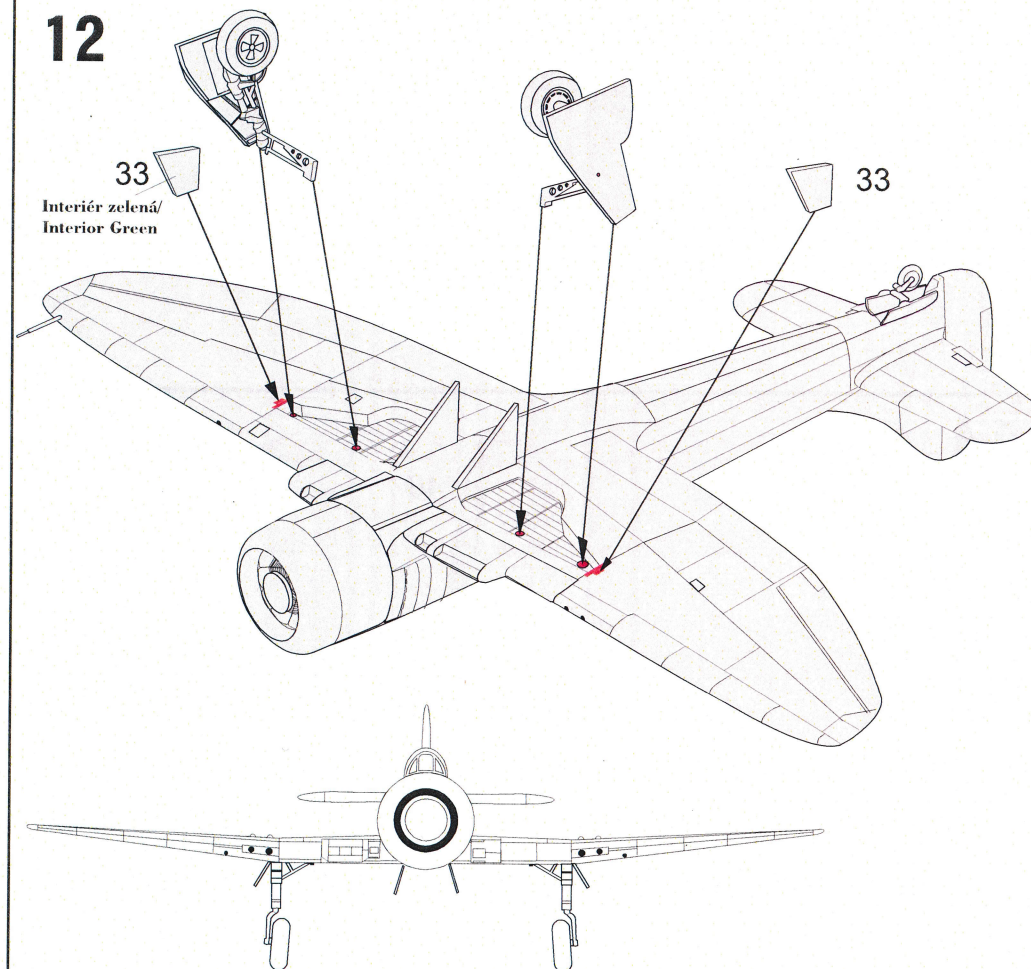

13

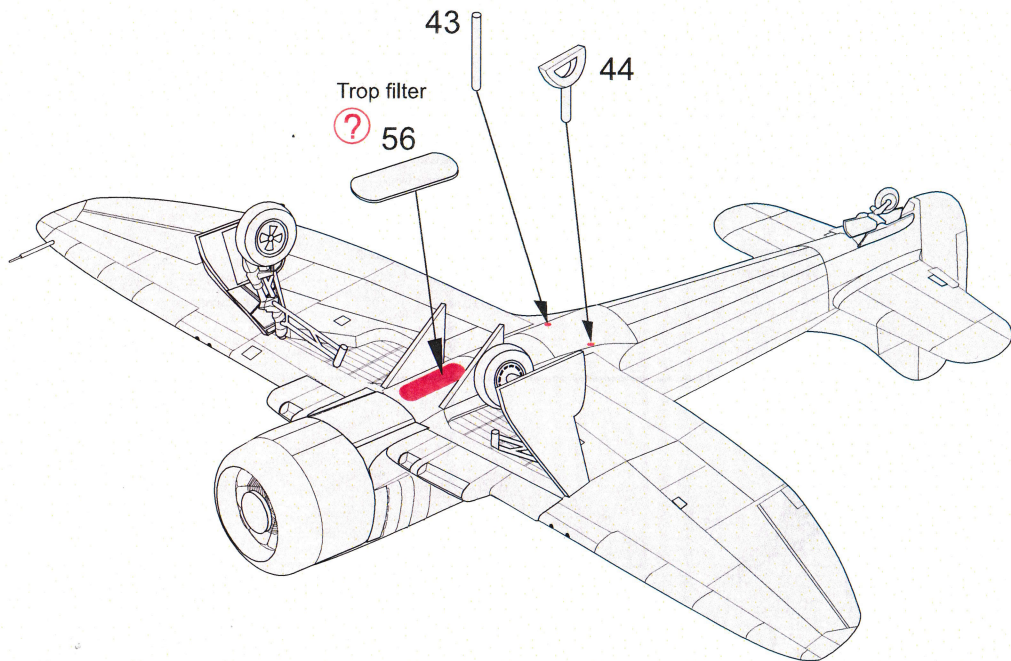

14

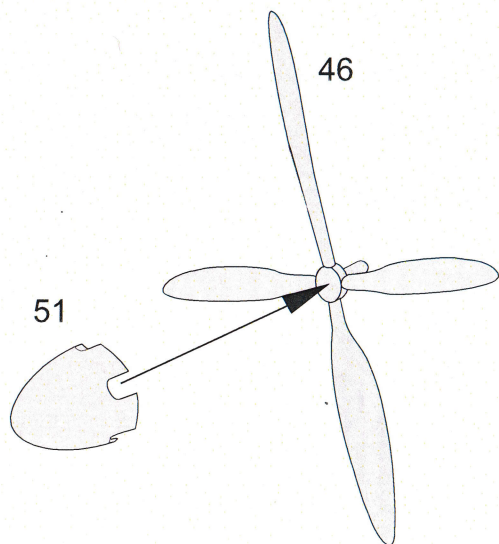

15

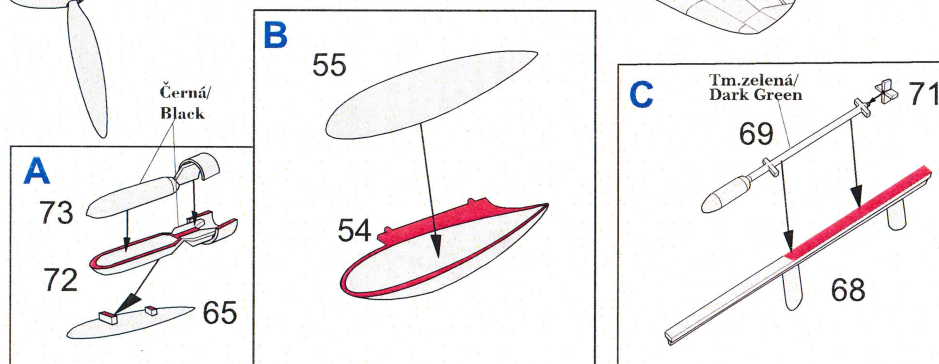
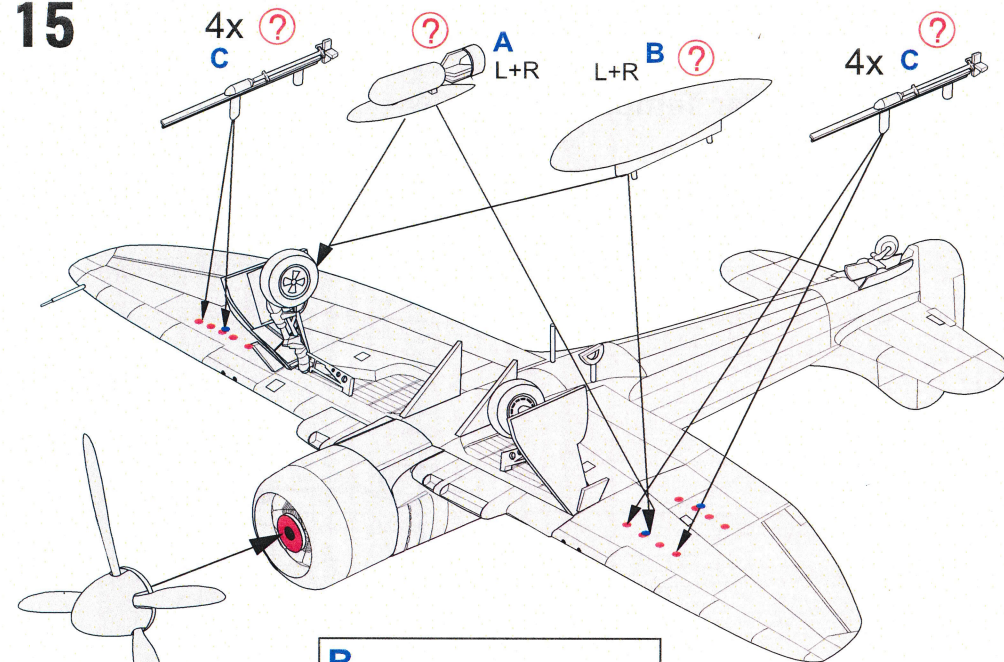

16

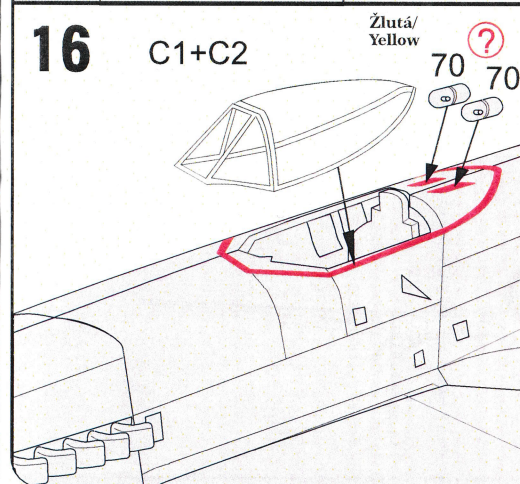

17

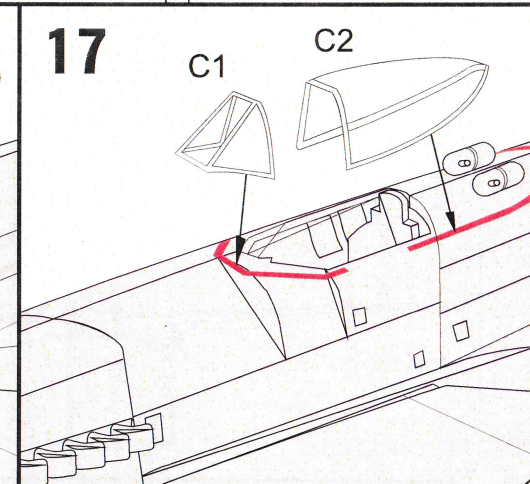

**1** Hawker Tempest F.2, A126, 14.squadrona , Pakistánské Královské letectvo, 1948.  
*Hawker Tempest F.2, A126, 14.squadrona , Royal Pakistan Air Force, 1948.*

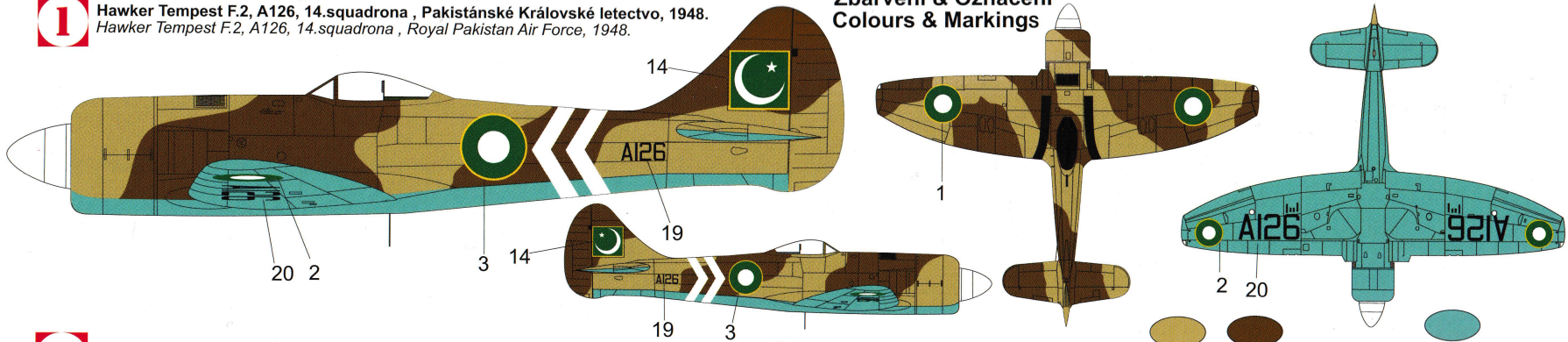

**Zbarvení & Označení  
 Colours & Markings**

- Písková Sand
- Tm. hnědá Dark Brown
- Azurově modrá

**2** Hawker Tempest F.2, H554, Indické Královské letectvo, 1947.  
*Hawker Tempest F.2, H554, Royal Indian Air Force, 1947.*

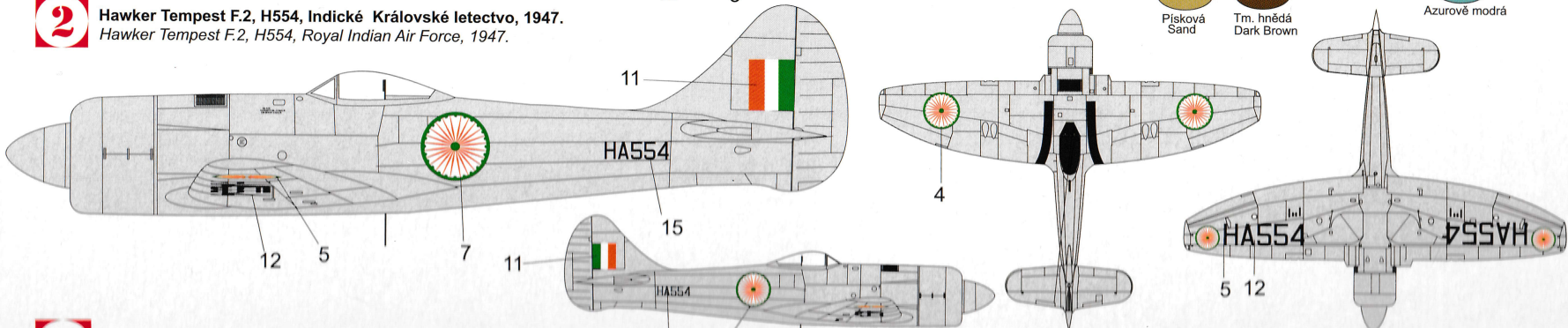

- Hliník Aluminium
- Černá Black
- Bílá White

**3** Hawker Tempest F.2, H552, Indické letectvo, 1955.  
*Hawker Tempest F.2, H552, Indian Air Force, 1955.*

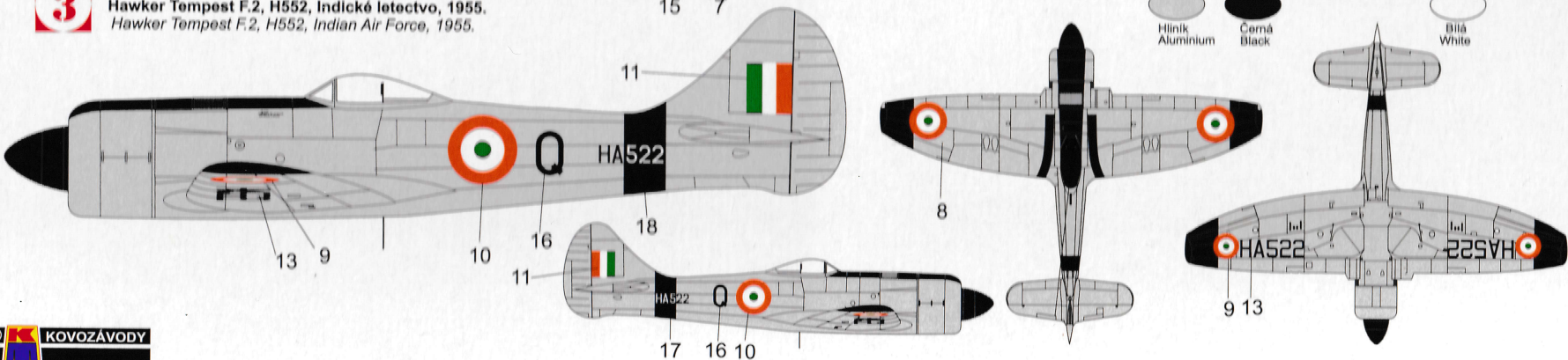

This construction kit contains one complete plastic model.  
 Glue and paints are not included. It may contain small parts and sharp edges.  
 Recommended for modelers of age 14 years and over.



Stavebnice obsahuje jeden kompletní plastkový model.  
 Neobsahuje lepidlo a barvy. Model obsahuje drobné díly - pozor na ostré hrany.  
 Doporučeno pro modeláře od 14 let věku.



Obtížnost/Skill



**KOVOZÁVODY**  
**PROSTĚJOV**



Tento výrobek je vyroben bez jakýchkoliv dotácných podpor.  
 Manufacture of this product was not funded by EU or any other public subsidies.