

# Russian T-72A Mod1985 MBT

## 俄罗斯T-72A Mod1985主战坦克

### READ BEFORE ASSEMBLY:

- Study and understand these instructions thoroughly before beginning assembly
- When needed, remove photo-etch parts carefully using a modeling knife or photo etch sprue cutter, being careful not to damage or lose small parts.
- Take extra care in handling photo etch parts in order to avoid injury
- Apply instant cement sparingly to photo etch parts where instructed
- Tools recommended(not included in kit):Plastic and instant cements, sprue cutters,long nose pliers,modeling knife, small files, tweezers, pin vise & scissors. Soft cloth and sandpaper will also assist in construction
- Glue and paint are not included in the kit. Use plastic cement and hobby paints only. Color guide for purchasing paint is included in the kit.

### 装配之前仔细阅读

- 小心用模型锉刀锉平所有零件表面的注射浇口。
- 小心用刀片切下蚀刻片零件，不要遗失小零件。
- 用强力快干胶水粘合蚀刻片零件和金属轴。过量快干胶水使用可能导致可动零件会粘住，小心涂胶。
- 取蚀刻片时应特别注意安全，防止利边划伤手指。
- 某些零件表面需贴水上贴纸，请选择在装配的同时进行。
- 推荐模型工具(自备)：胶水，水口剪刀，长咀钳，刀片，锉刀，镊子，钳，钻，剪刀，瞬间快干胶。
- 软布同砂纸同时也应该是必备工具。
- 请使用塑料胶水和油漆，模型内不含。



配重  
Weight



使用强力胶  
Cyanoacrylate glue



钻孔  
Make hole



切除  
Cut / Remove



贴纸  
Decal



锉平  
File / Sand



选择  
Option



不涂胶水  
No cement



弯曲  
Bend



先装  
Install it first

### 水贴纸的使用:

- 1.从水贴纸上剪下印花;
- 2.将印花放入温水中浸10秒, 然后放在干净布上。
- 3.拿着印花纸板将印花移到模型上;
- 4.手指蘸水将印花移到适当的位置;
- 5.用软布轻压印花直至水干, 气泡消失

### DECAL APPLICATION

- 1.Cut decals from sheet as needed
- 2.Dip the decal in warm water for about 10 seconds and then place on soft clean cloth.
- 3.Hold the decal backing sheet edge and gently slide the decal onto the model in its proper position.

- 4.While still wet,decal can be adjusted for better fit on model by dampening it gently with your finger.
- 5.When placed in the proper position,gently press decal down with a soft cloth until excess water and air bubbles are gone.
- 6.Allow decal to dry completely before handling model



# 部品图 Parts

**Ax2**

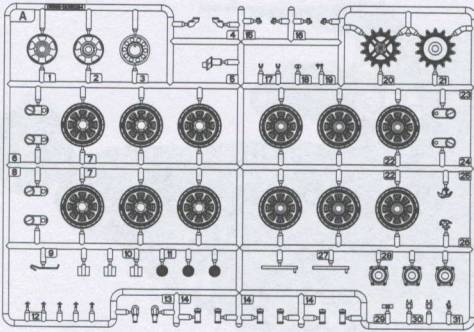

**B**

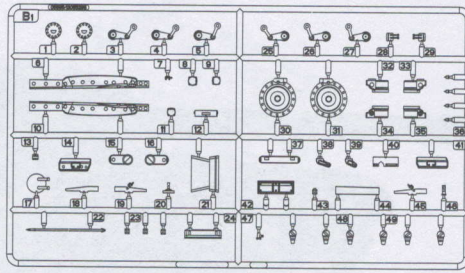

**P**

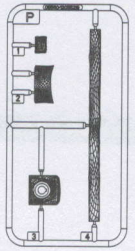

**C**

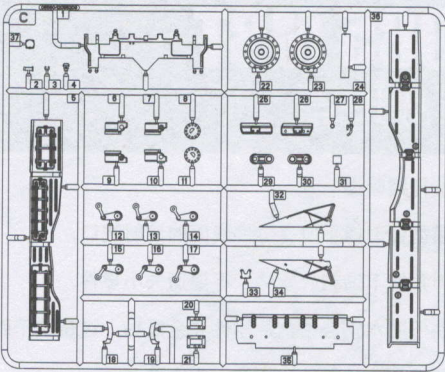

**G**

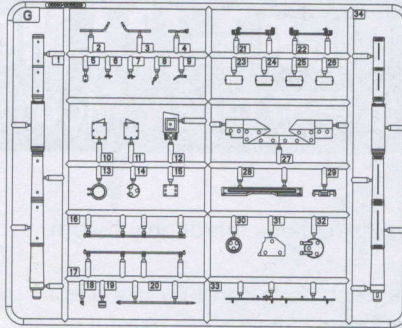

**Q**

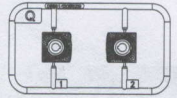

**GP**

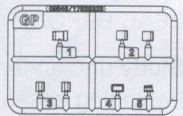

**H**

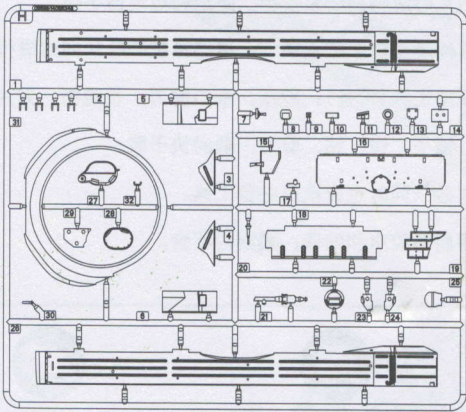

**K**

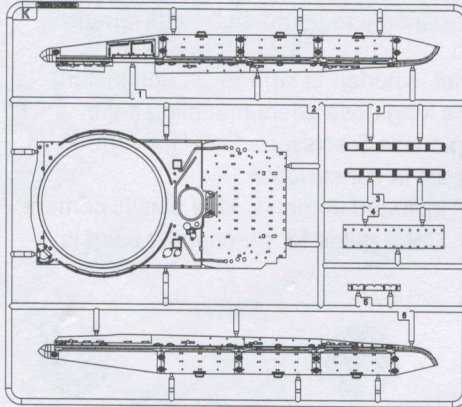

《炮塔》  
Turret

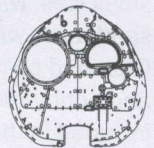

《蚀刻片-A》  
PE-A x2

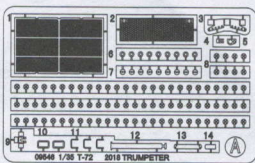

《蚀刻片-B》  
PE-B

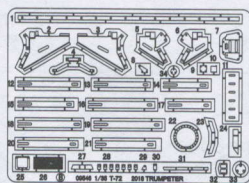

《蚀刻片-C》  
PE-C

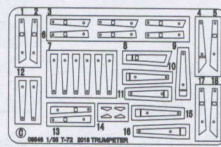

《轮塞》  
Poly cap

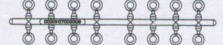

《铜丝》  
Copper wire



《软管》  
Vinyl tubing



《铜线》  
Brass wire



**R1**

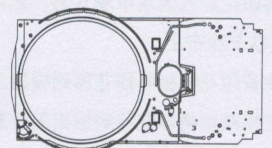



N

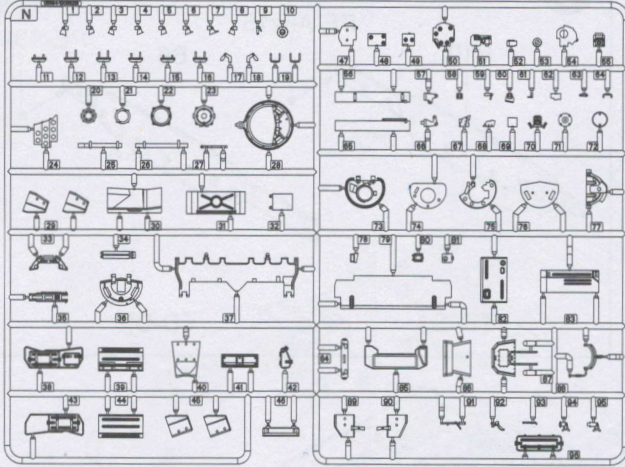

K1

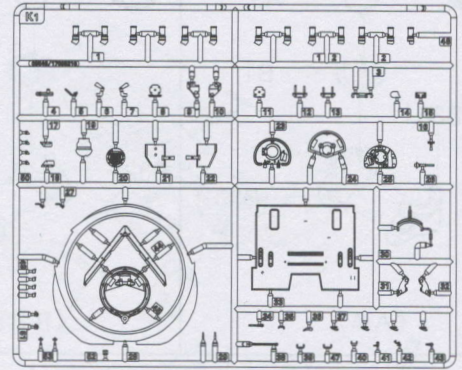

M

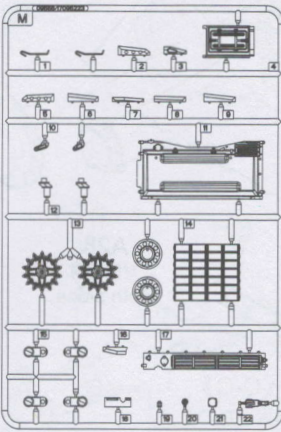

S

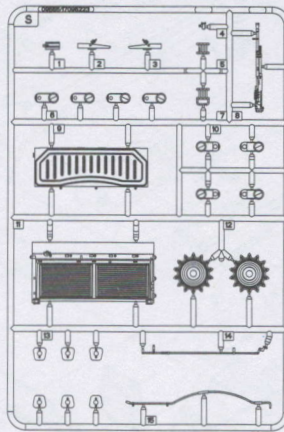

L1

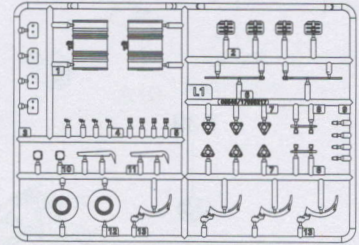

L3

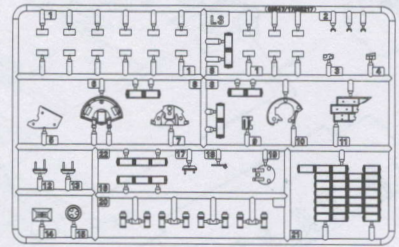

A1x4

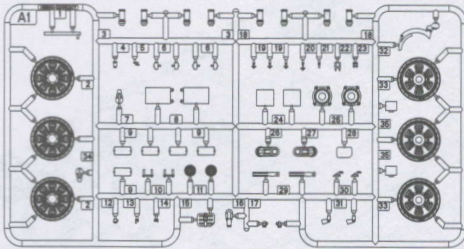

Nx7

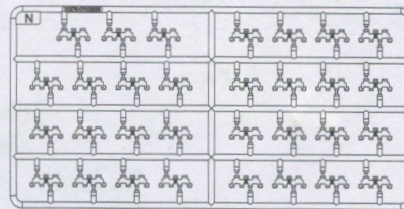

U

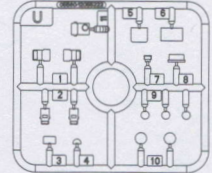

Lx4

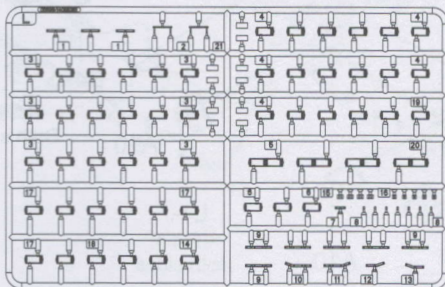

《车底》  
Lower hull

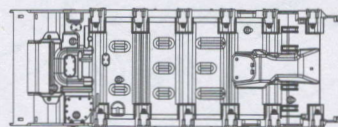

《水贴》  
Decal





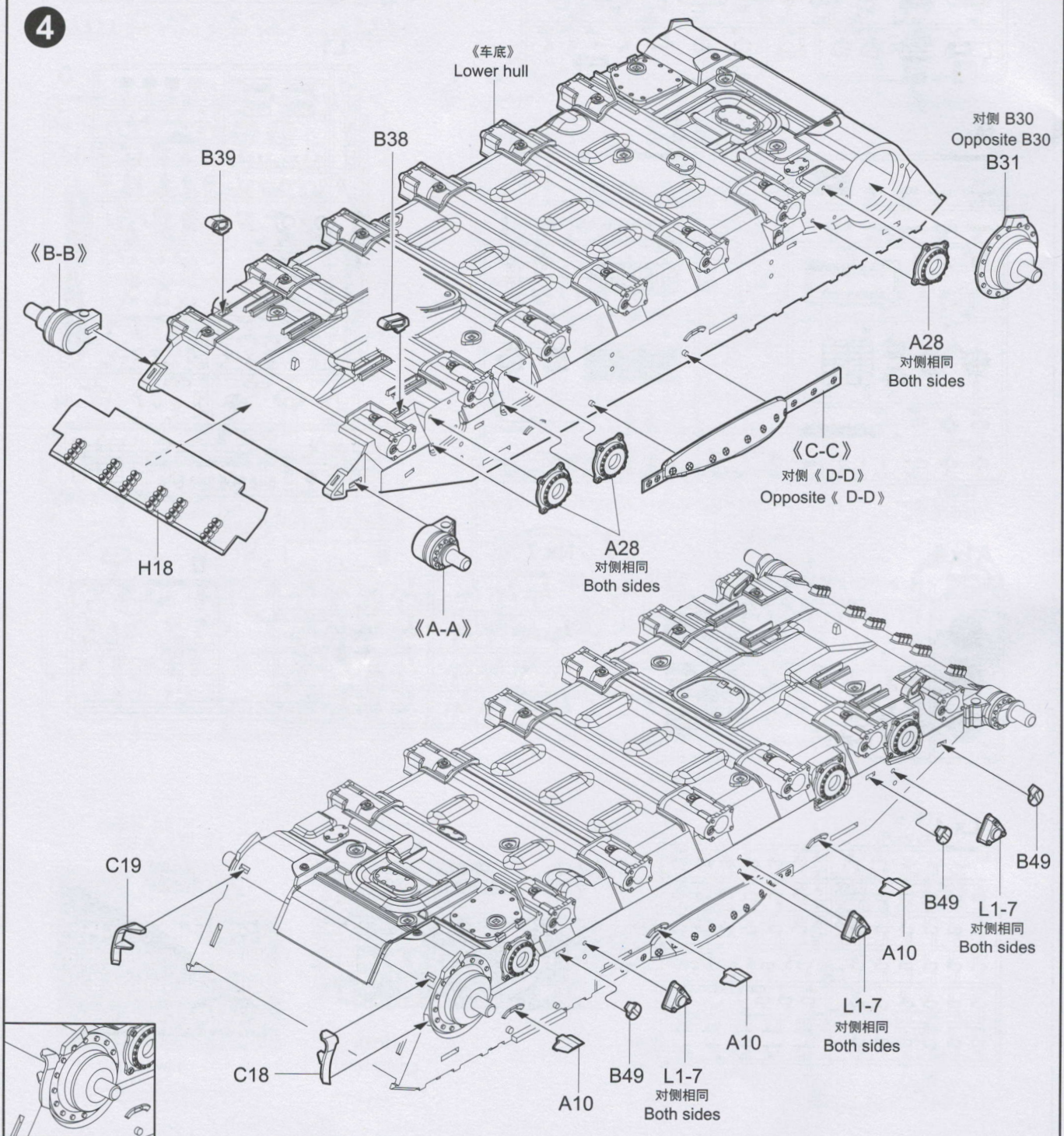
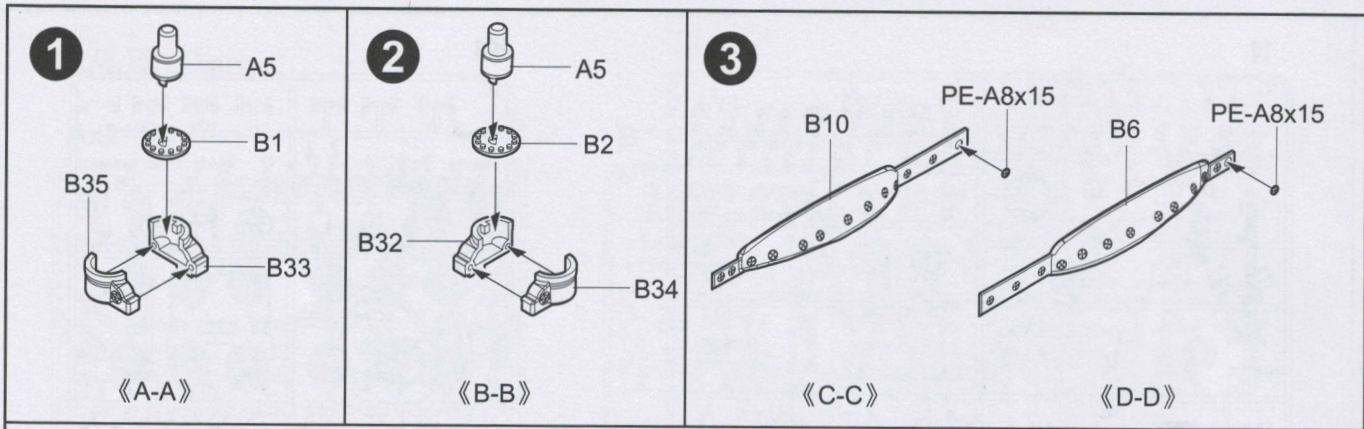



5

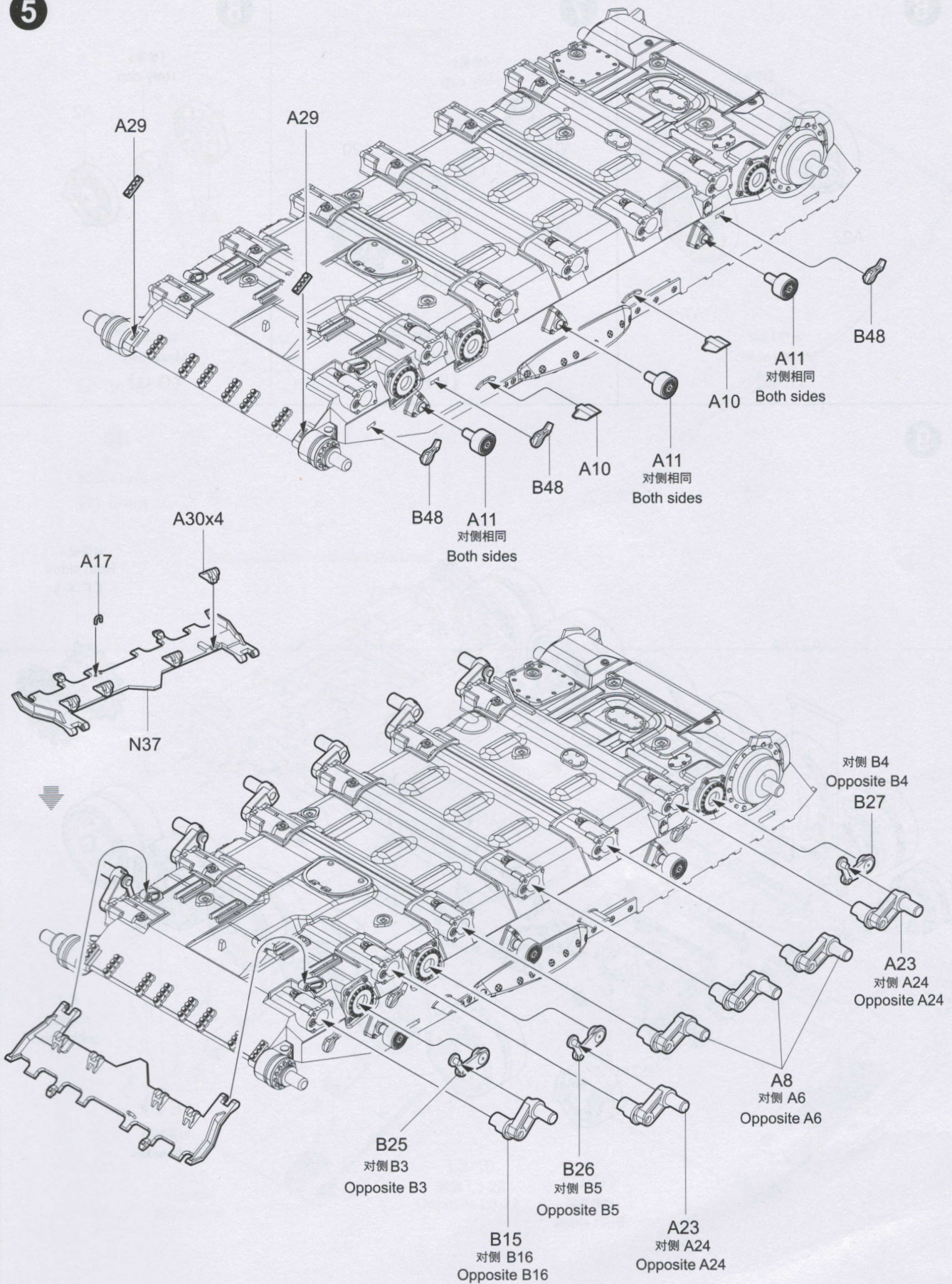



6

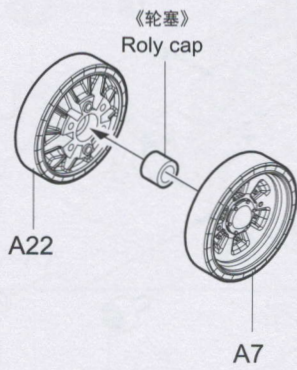

制作12组  
Make twelve  
《E-E》

7

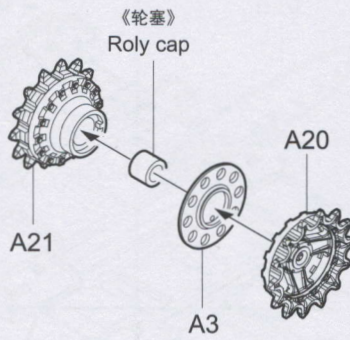

制作2组  
Make two  
《F-F》

8

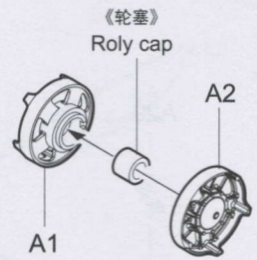

制作2组  
Make two  
《G-G》

9

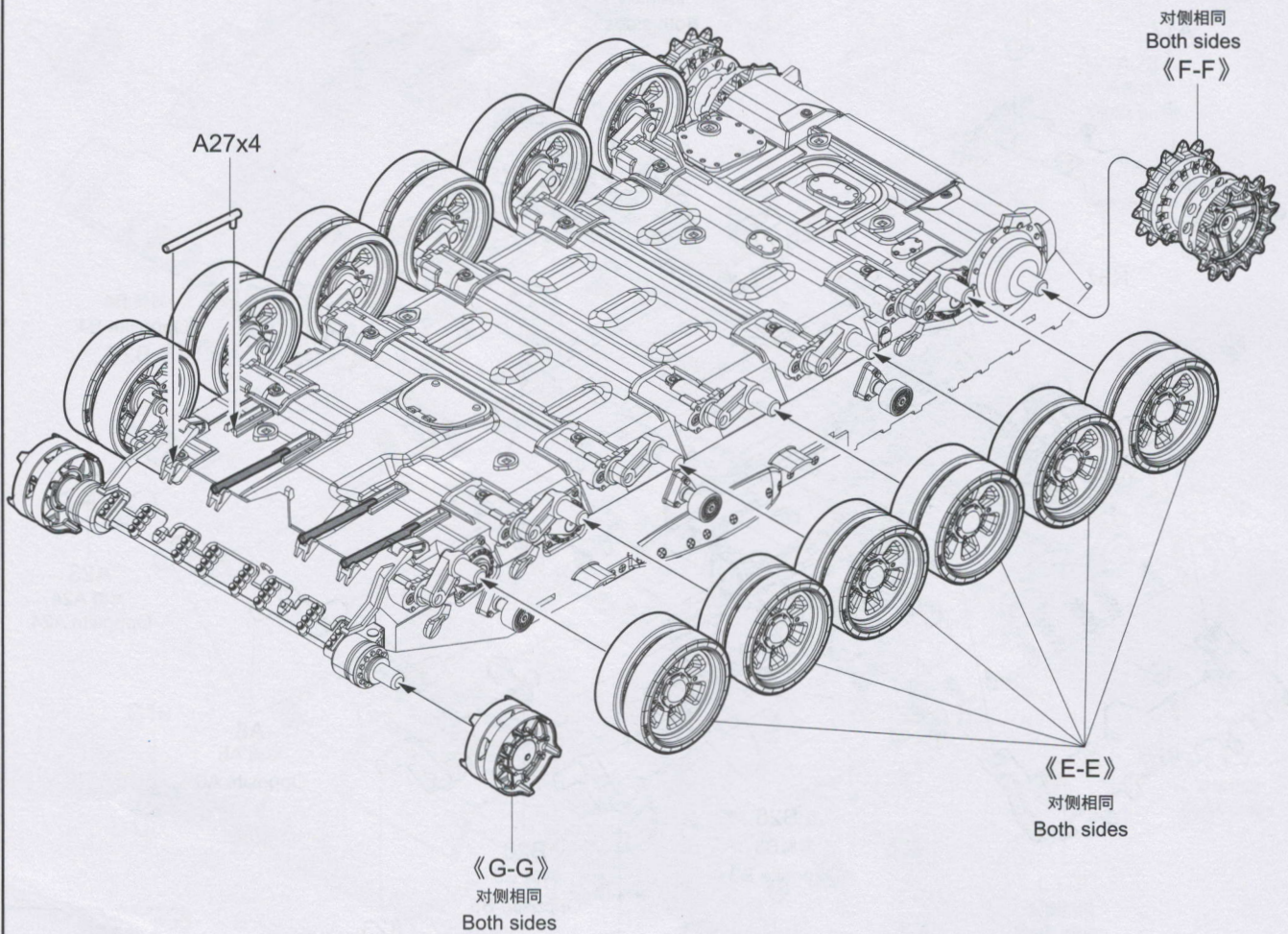



10

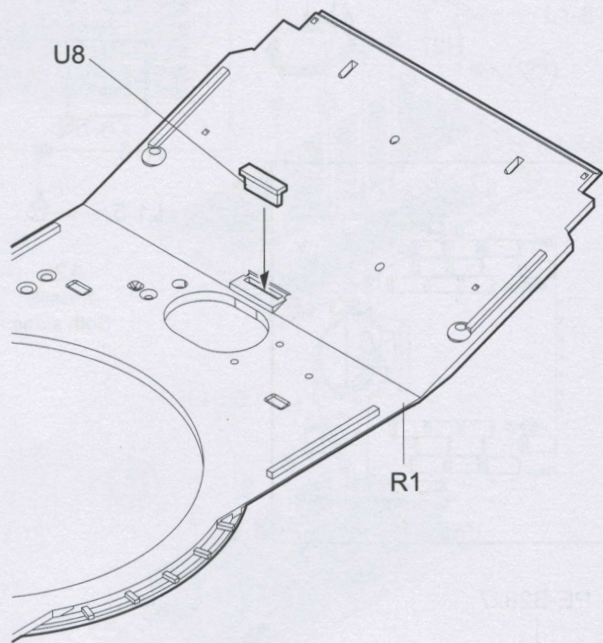
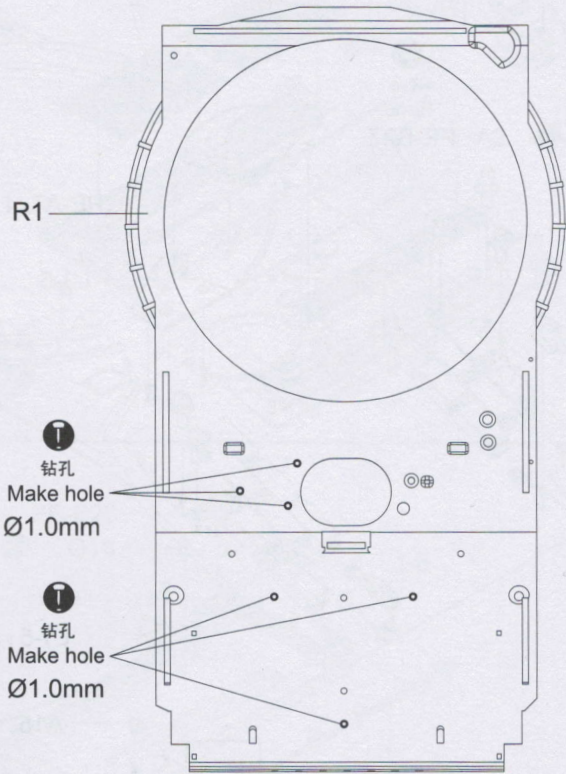

11

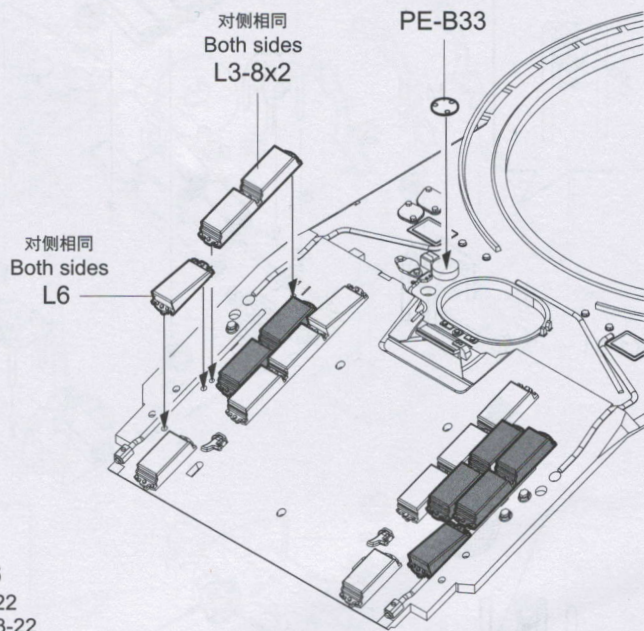
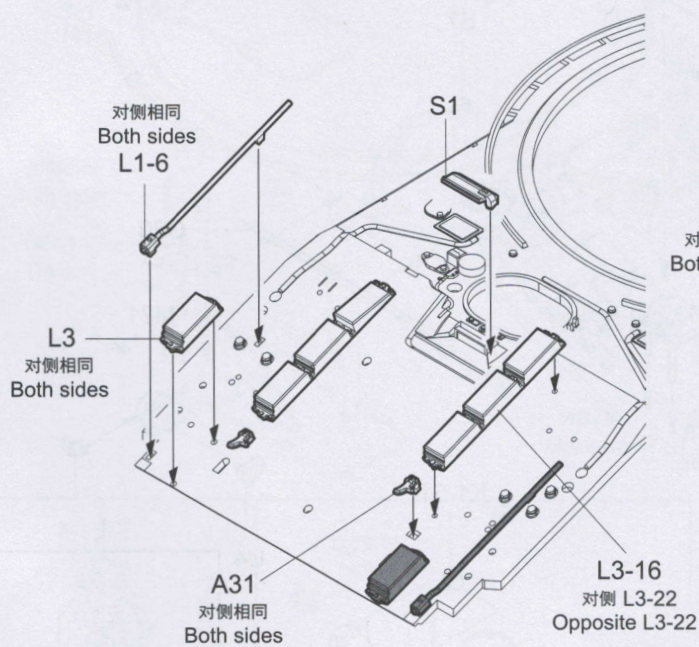



12

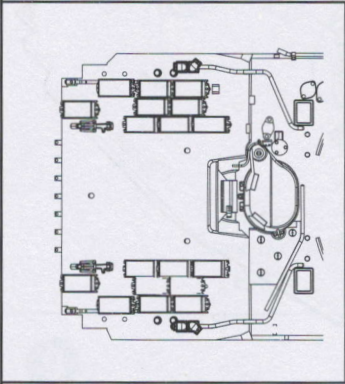
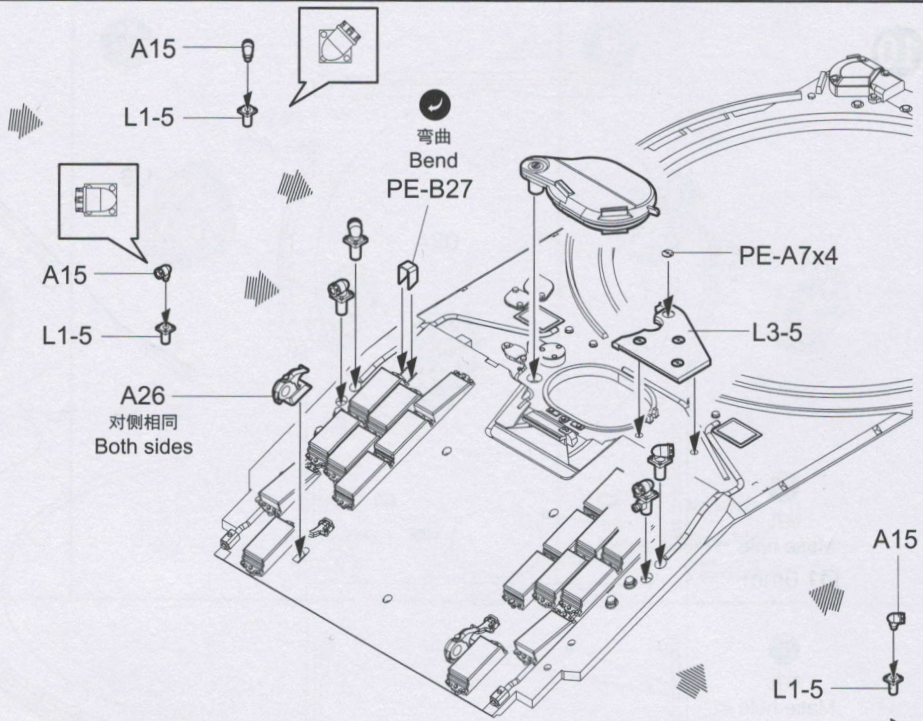
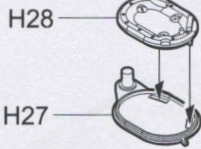

PE-B28x7

L3-21

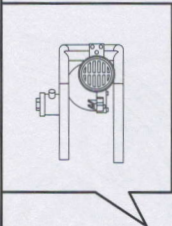
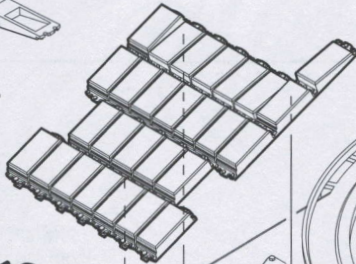
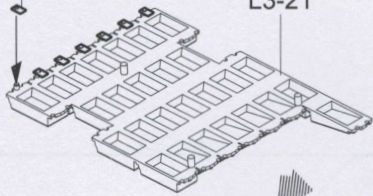

M20

K1-51

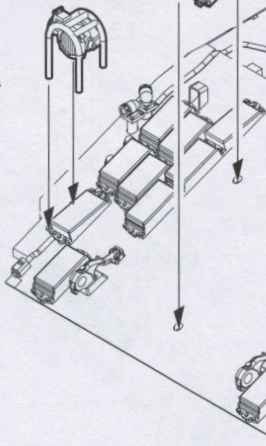

B7

G20

M21

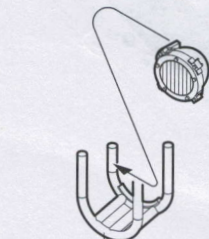

S5

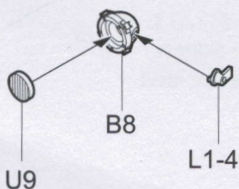

U9

B8

L1-4

K1-51

S7

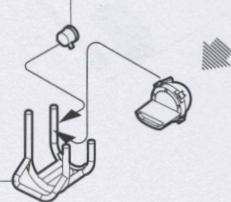

U4

L1-4

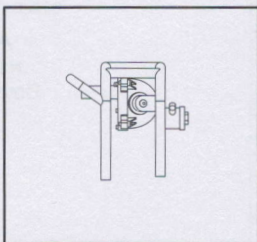
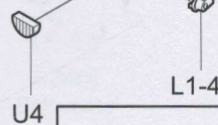



13

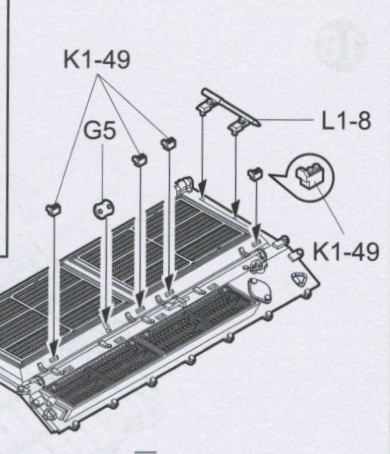
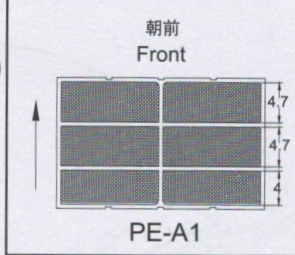
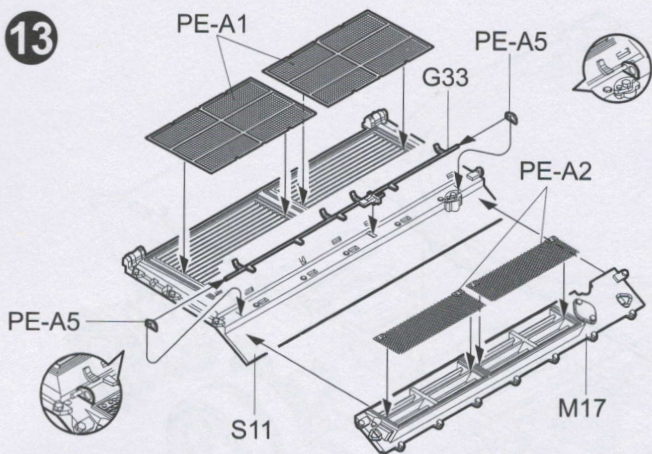

14

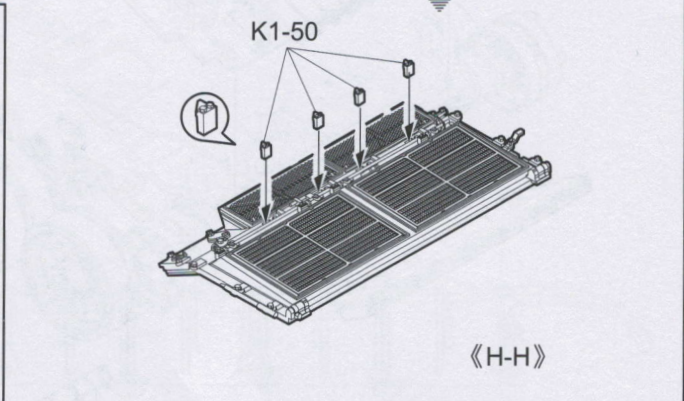
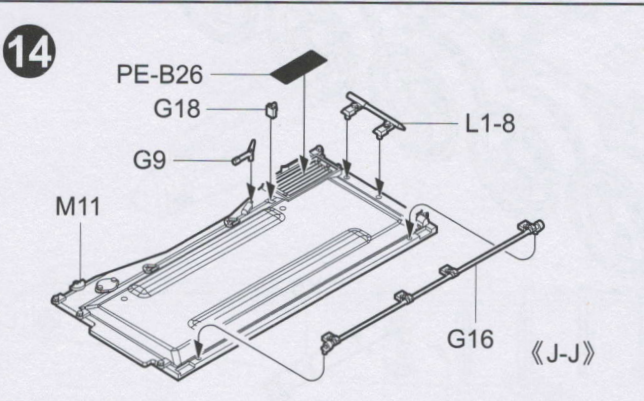

15

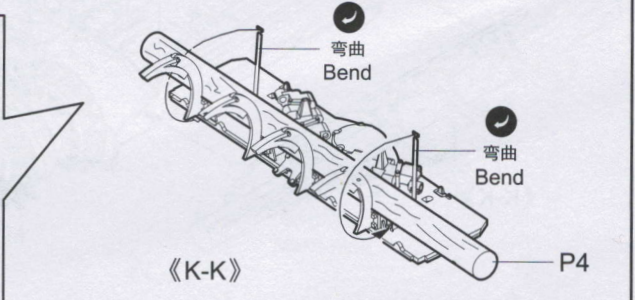
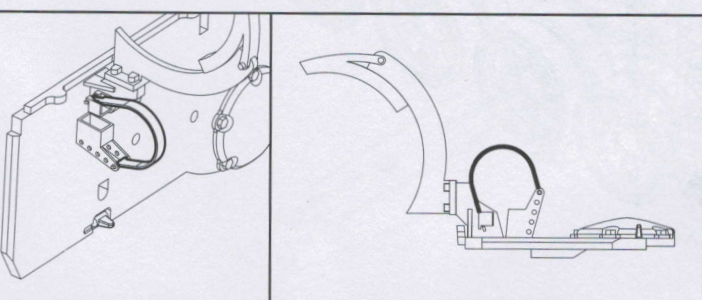
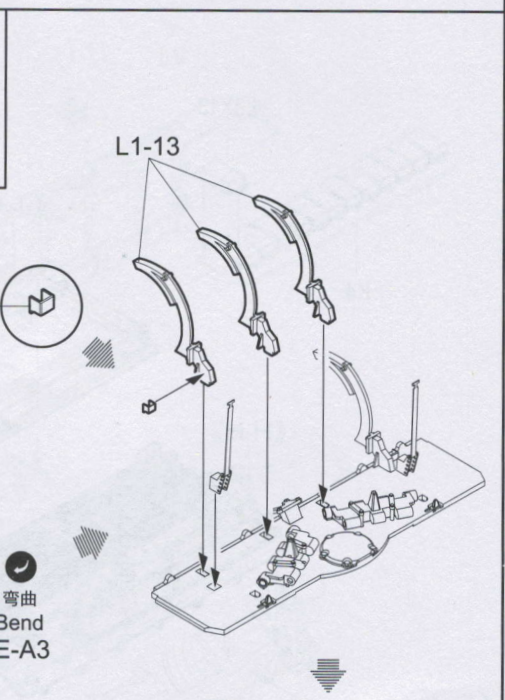
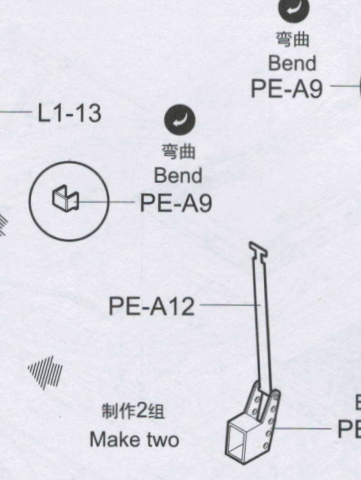
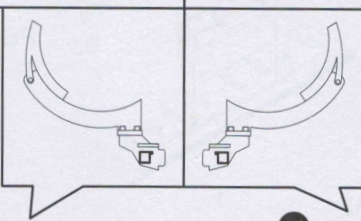
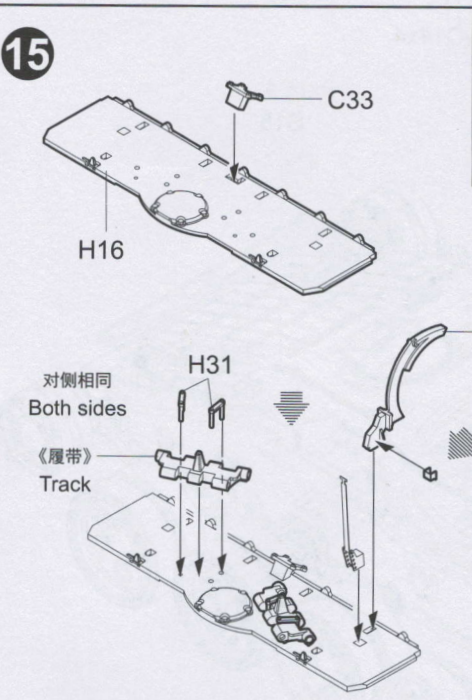



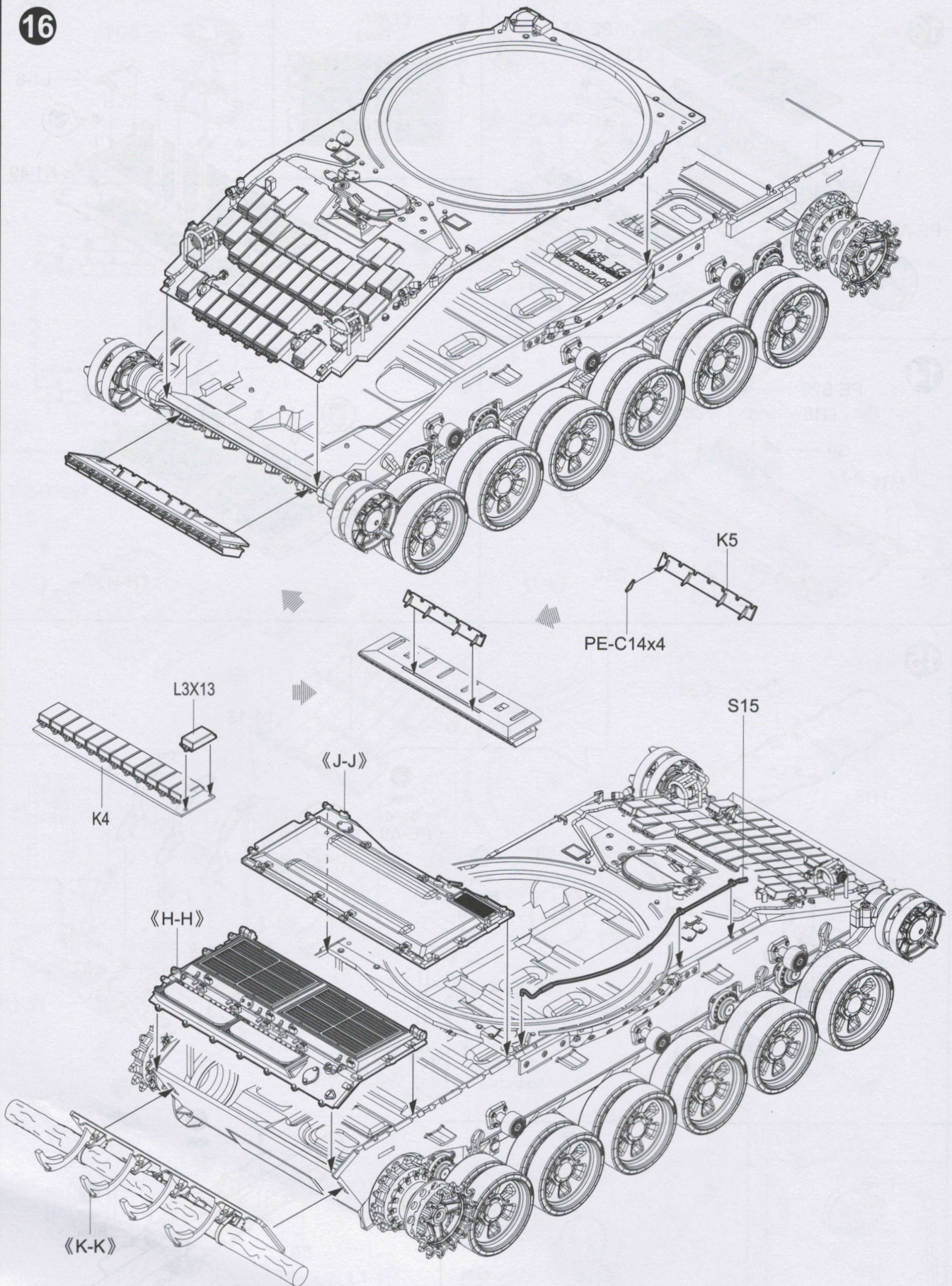



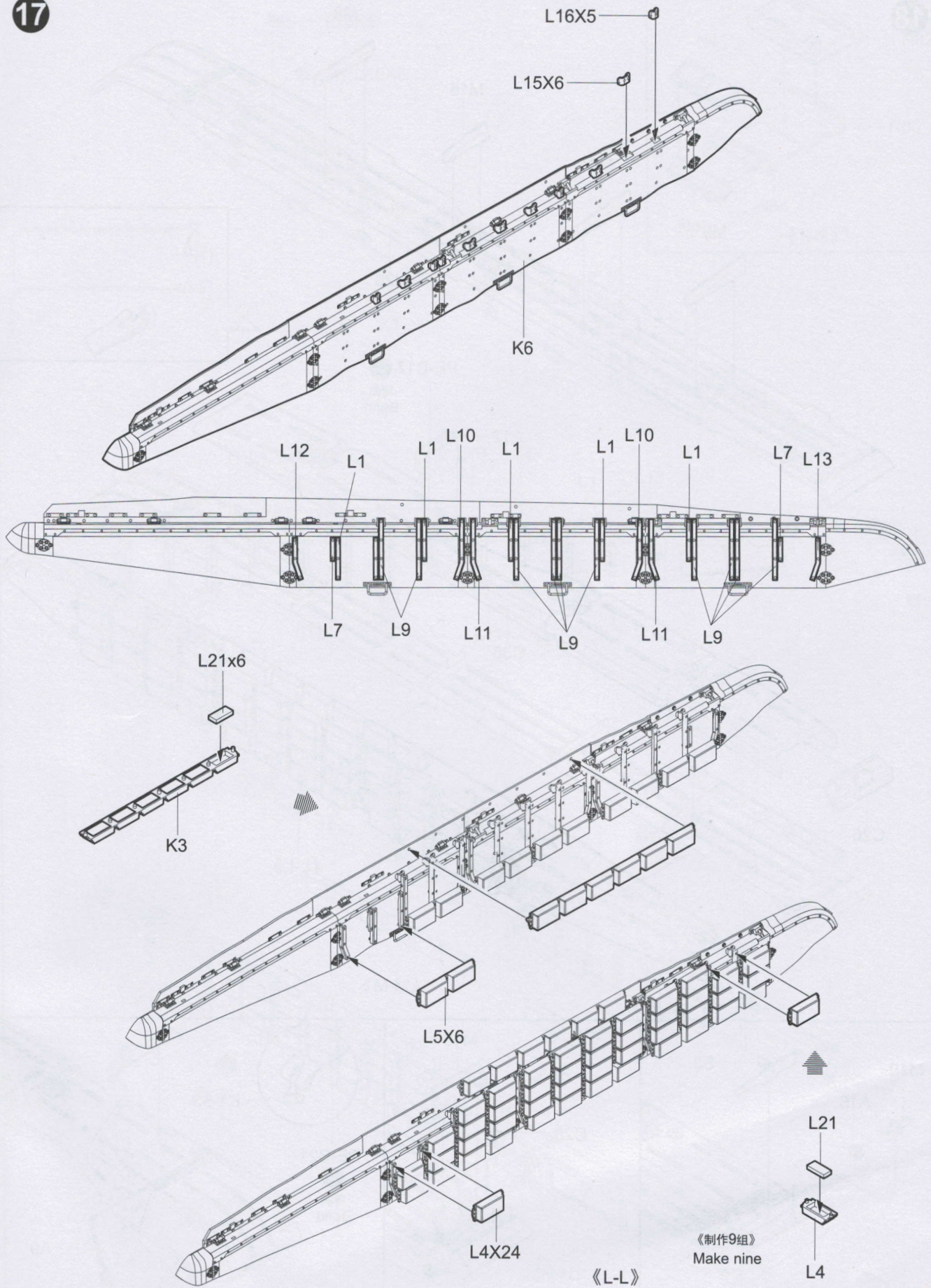



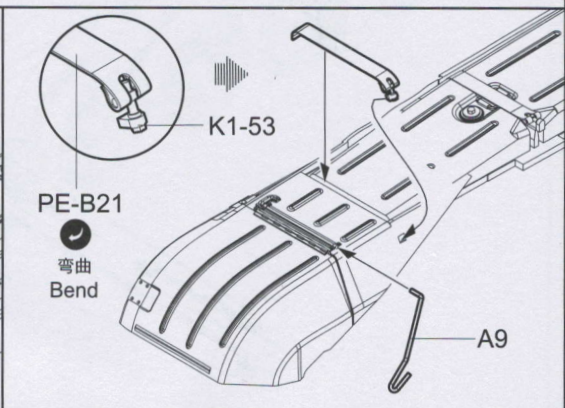
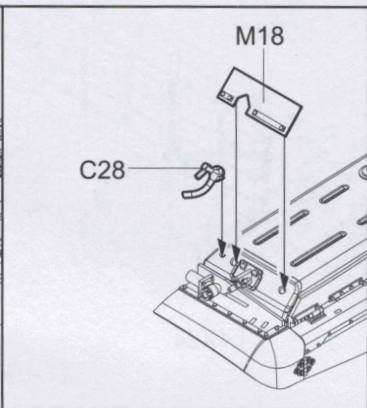
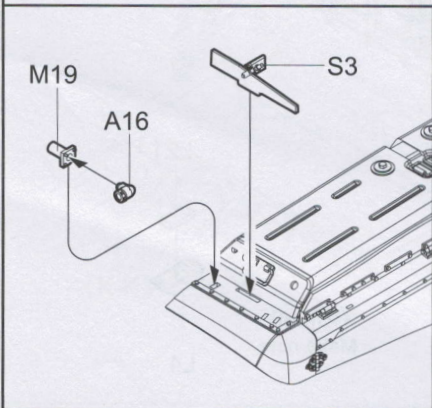
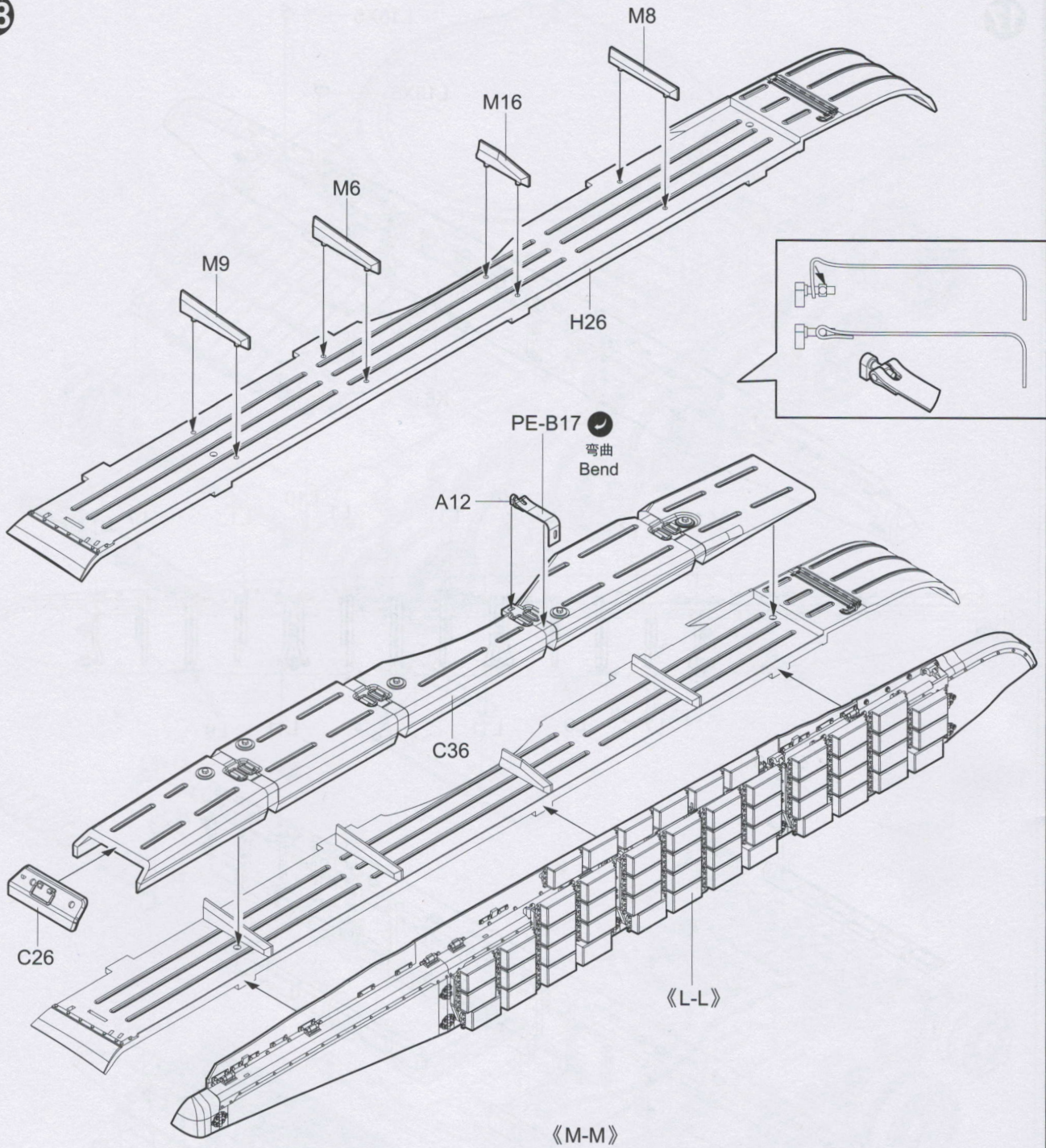



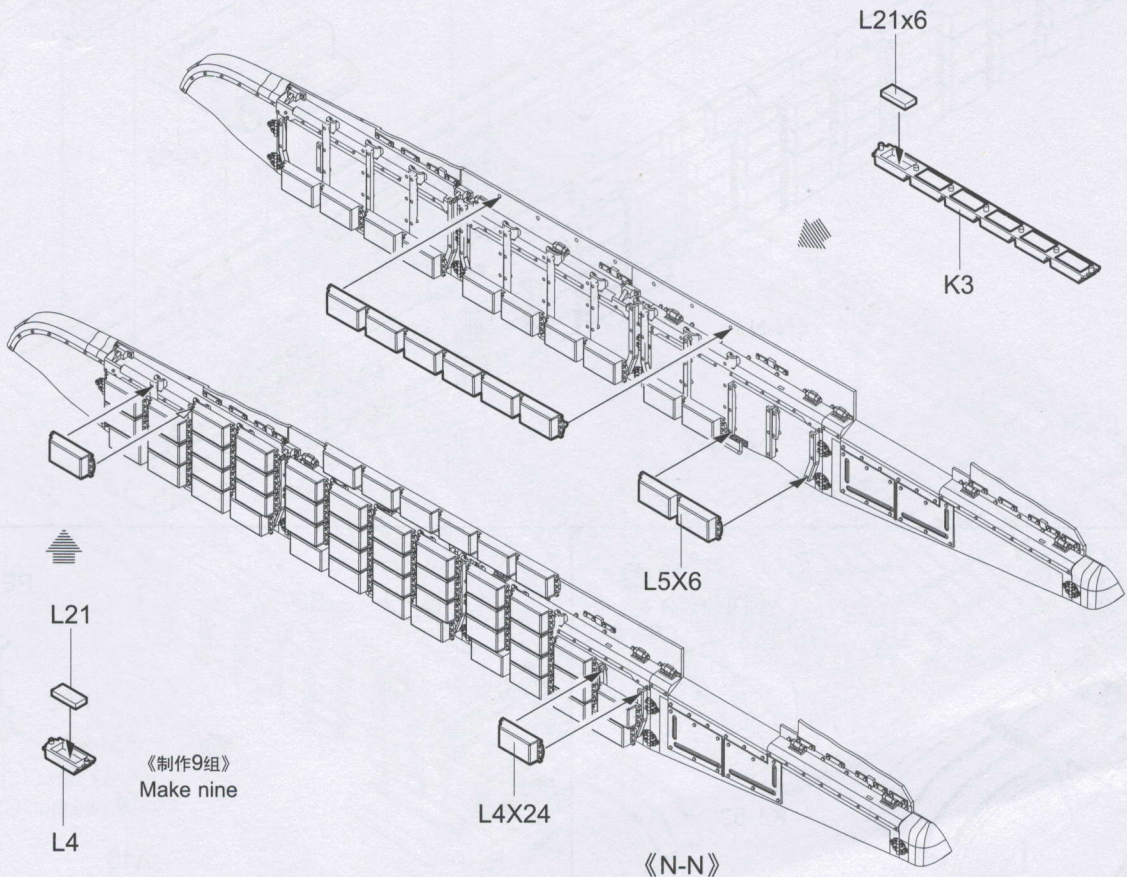
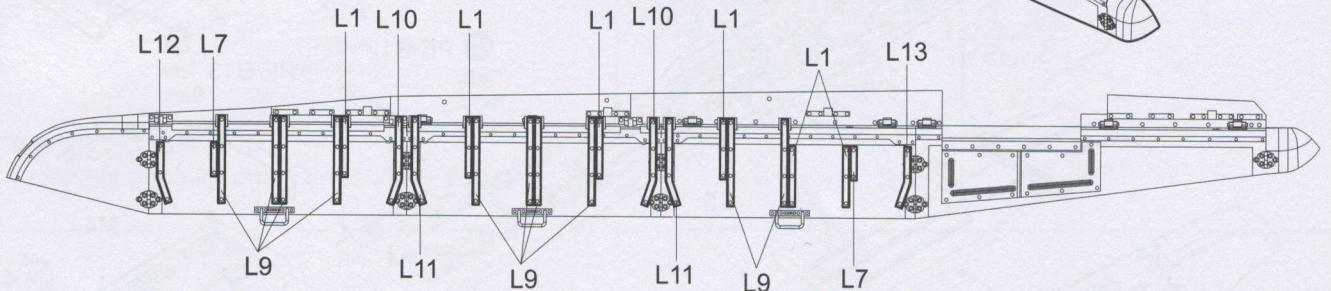
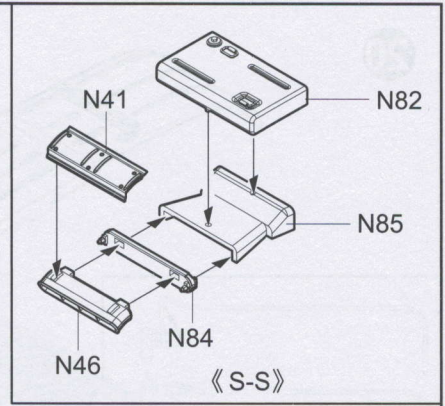
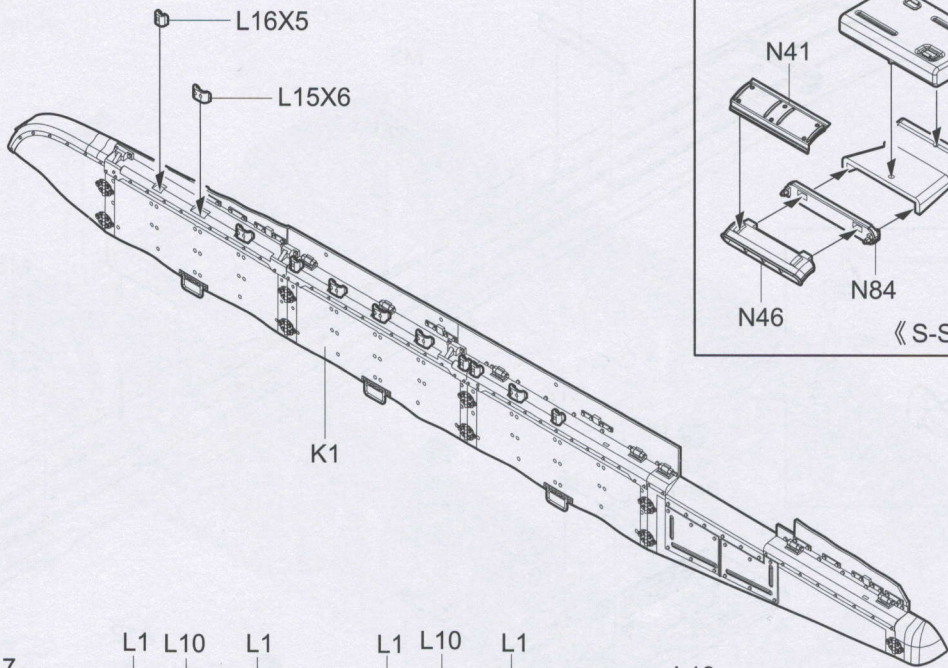



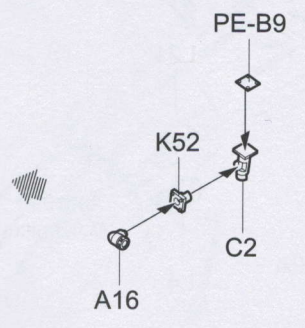
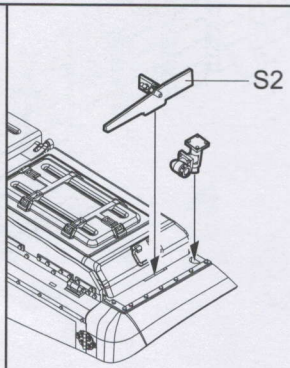
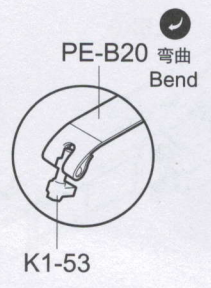
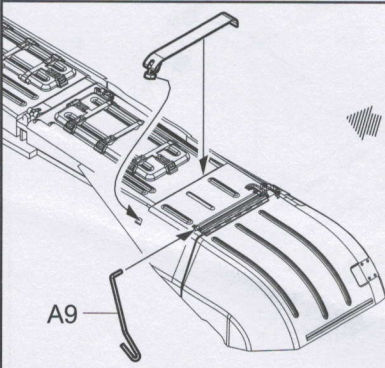
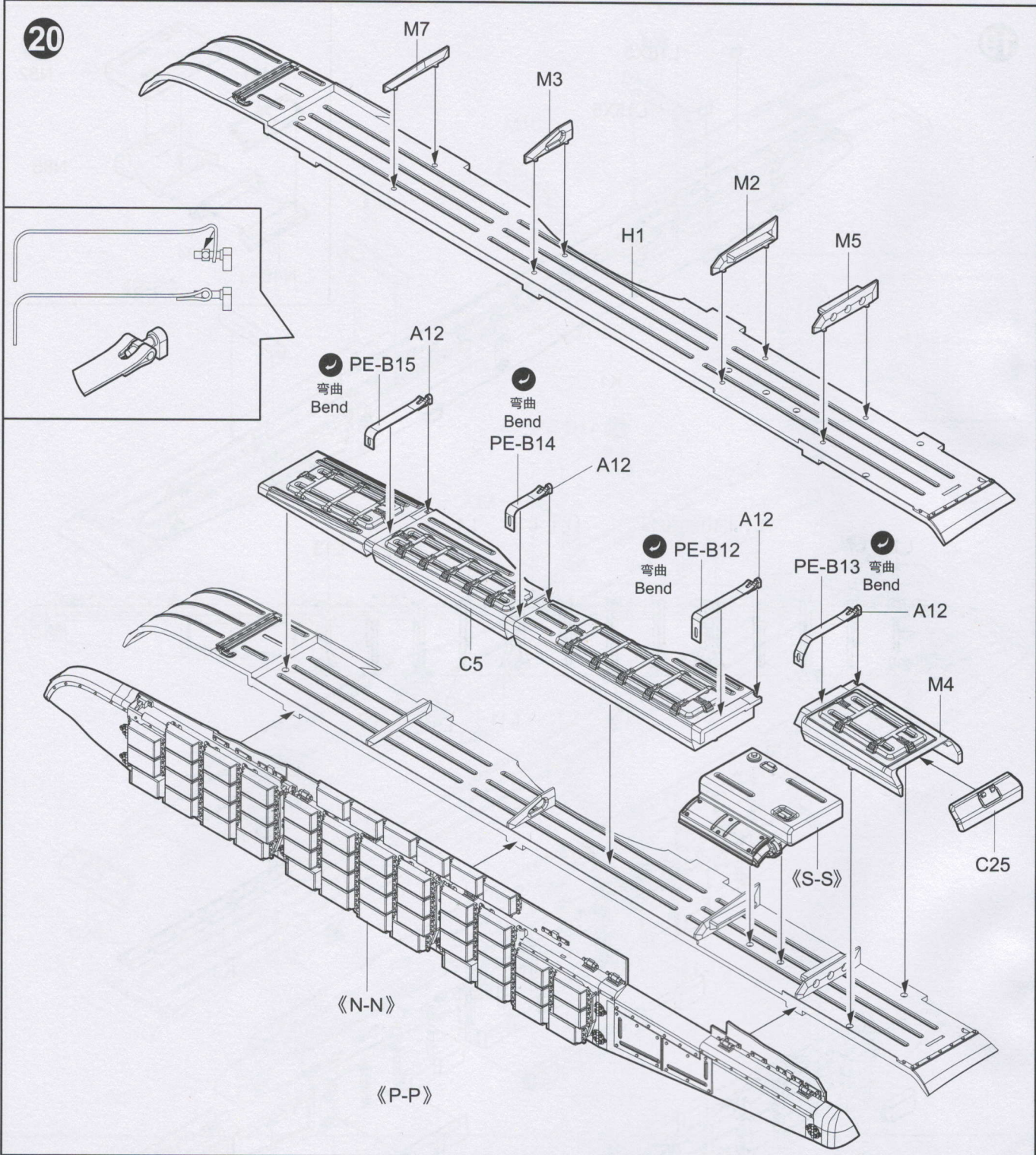



21

履带组装  
Track assembly

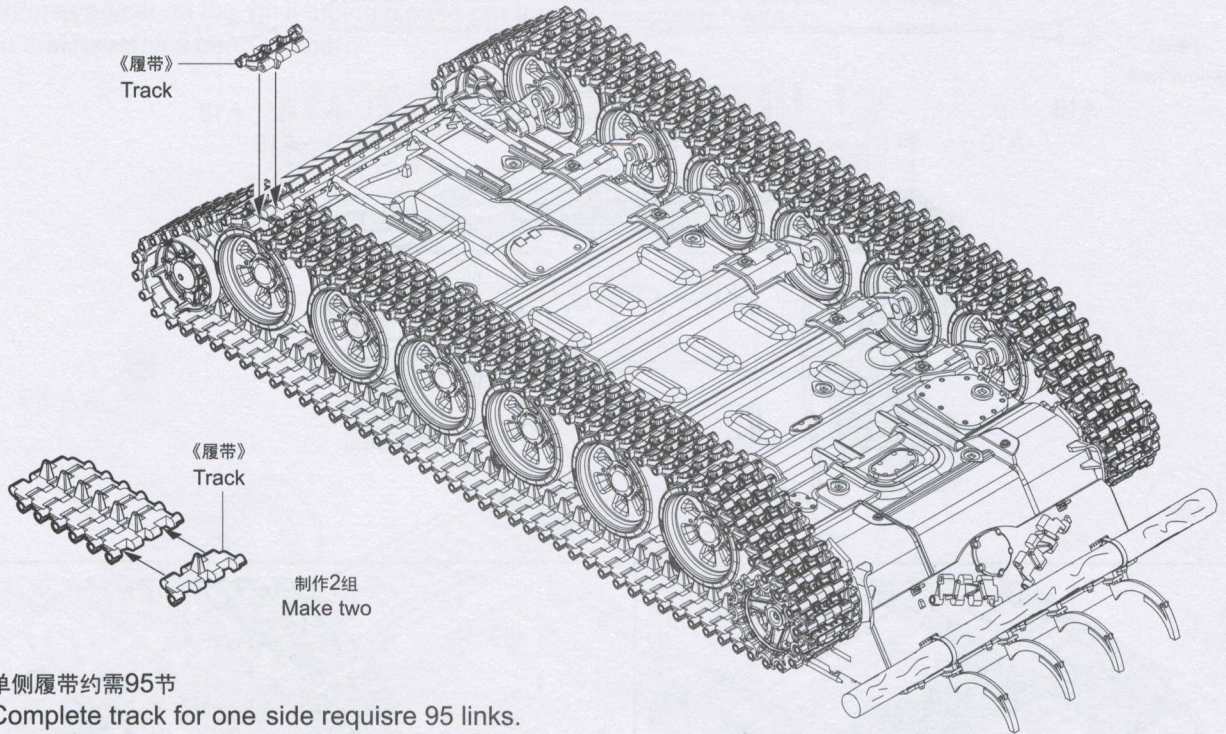

22

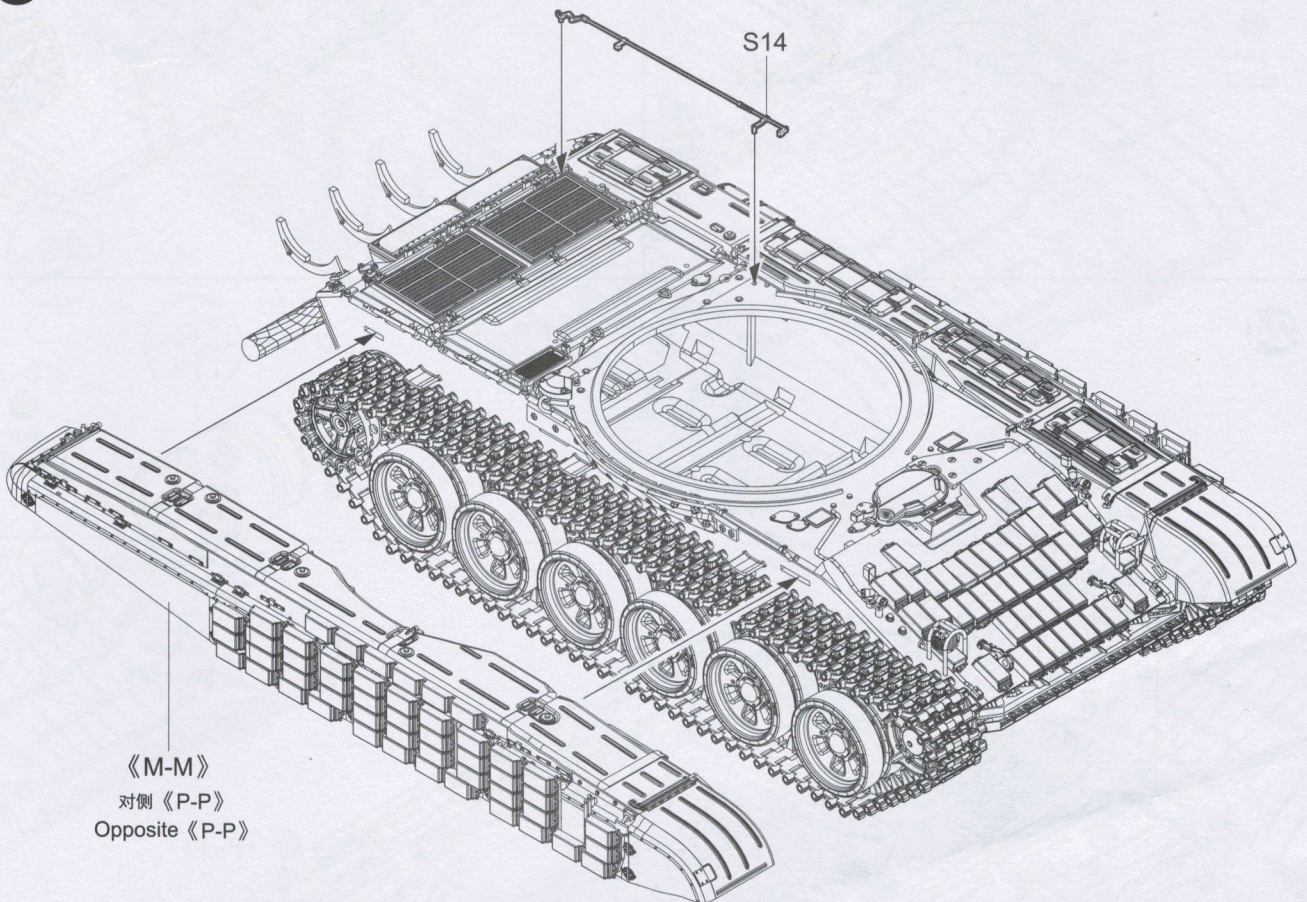



23

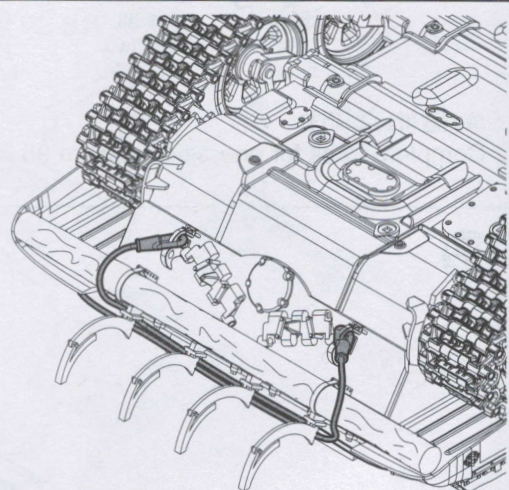
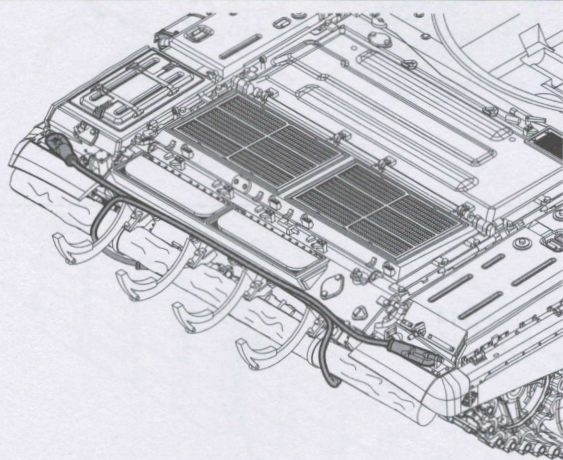
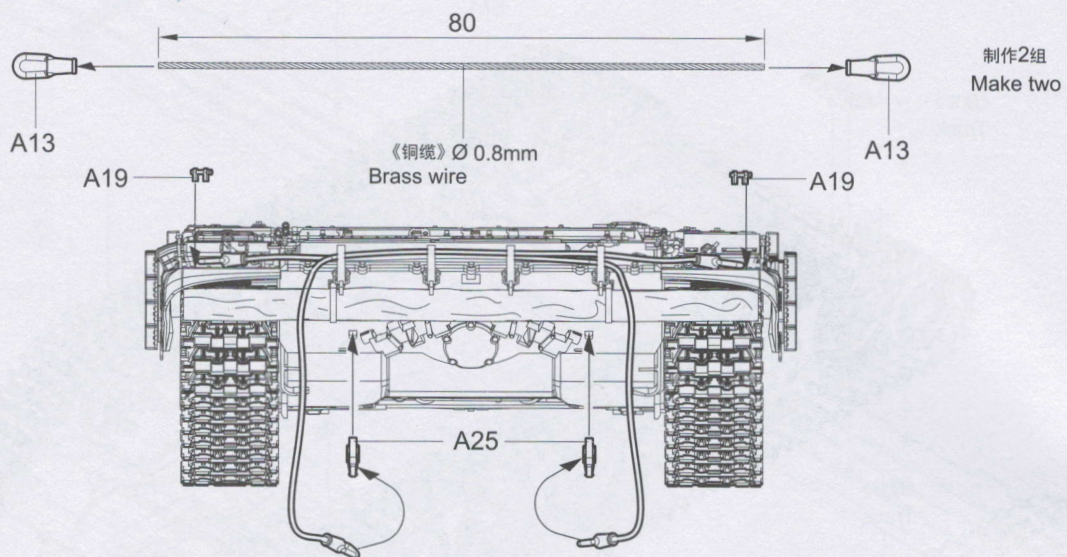

24

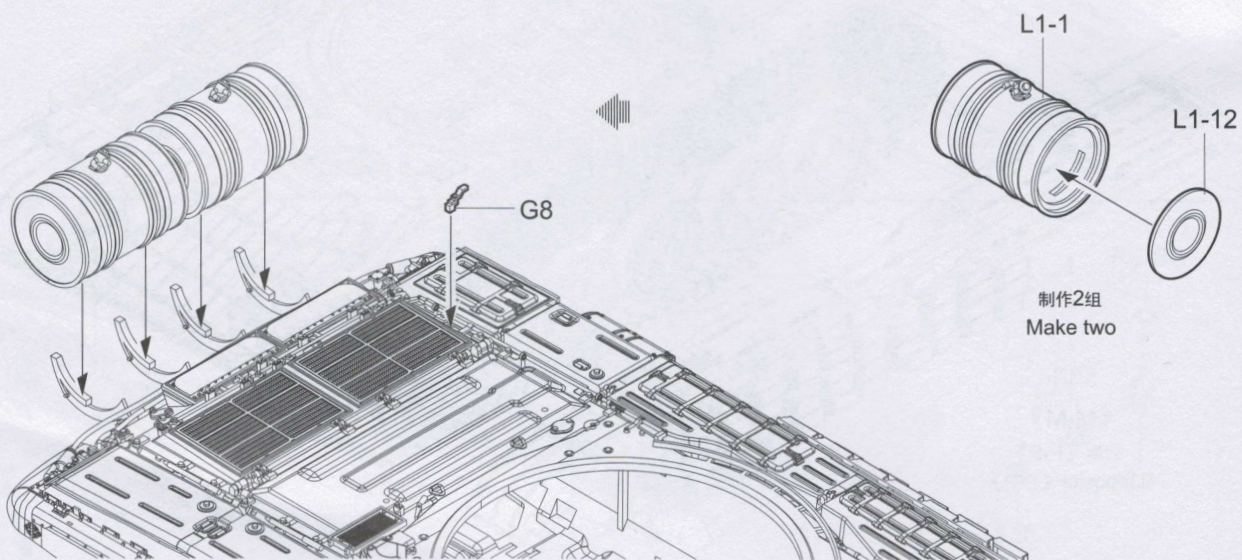



装配软管前请先穿入铜丝，使之保持弯曲状态。

Before you set up the vinyl tubing, please get through the copper-wire, so that it remains bend shape.

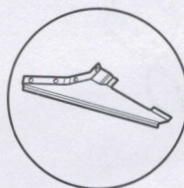
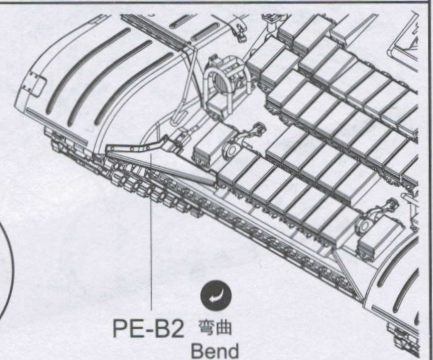
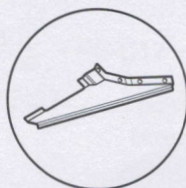
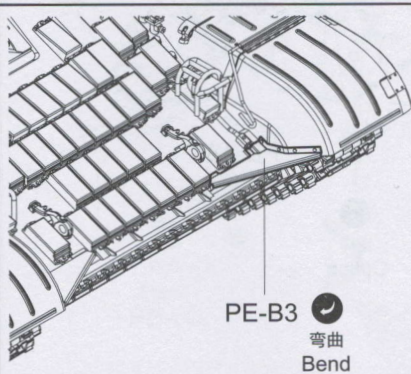
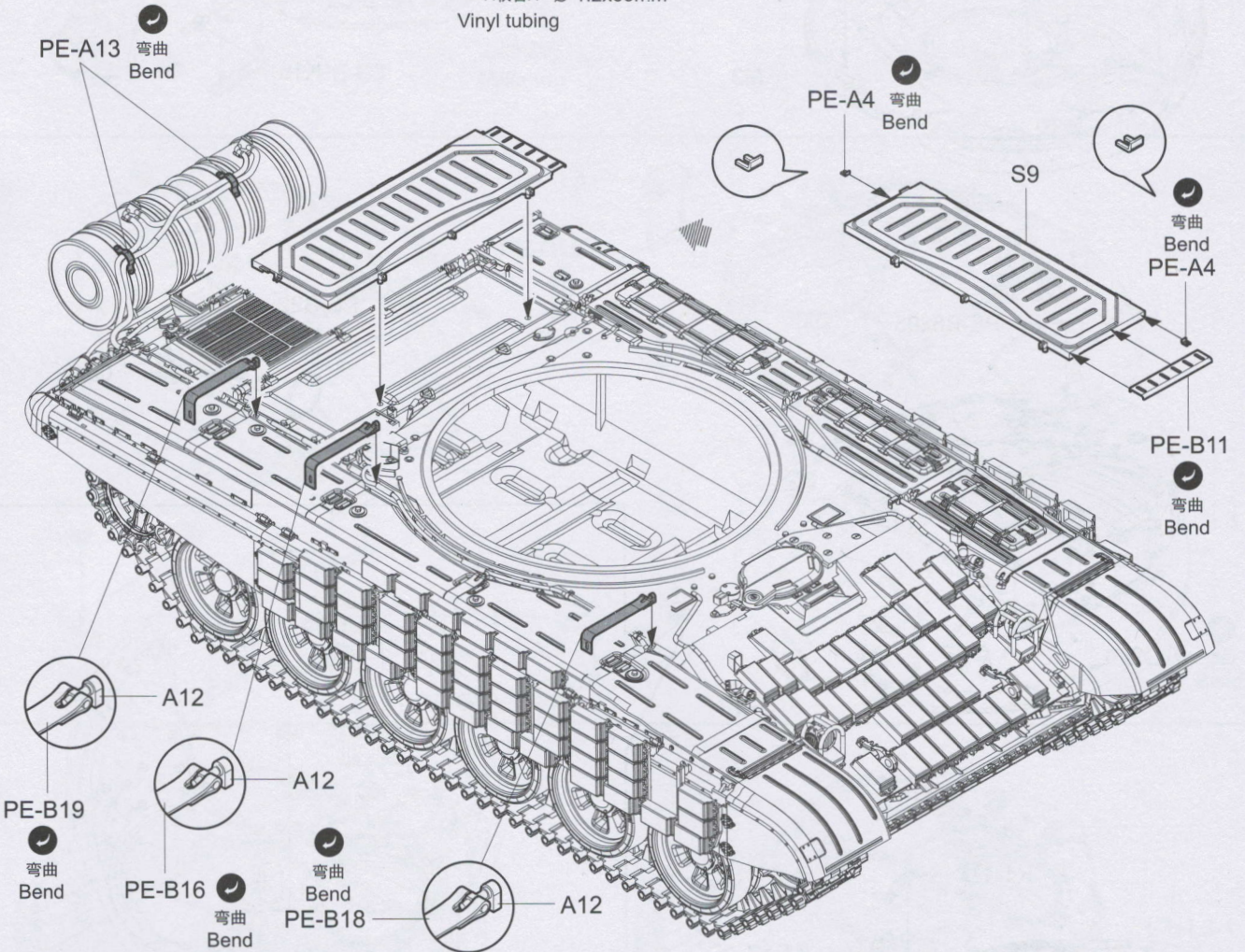
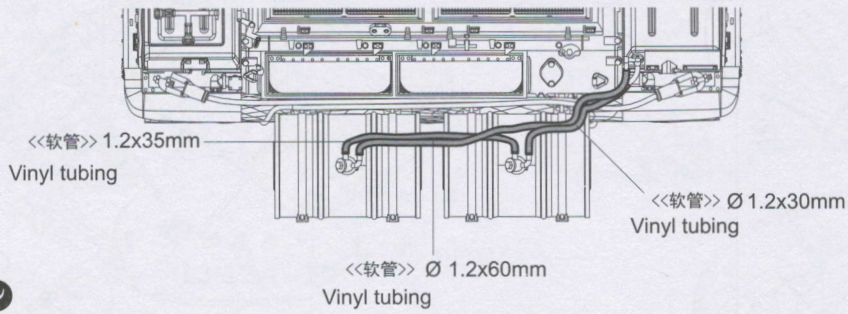
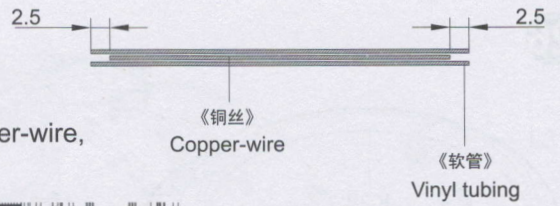



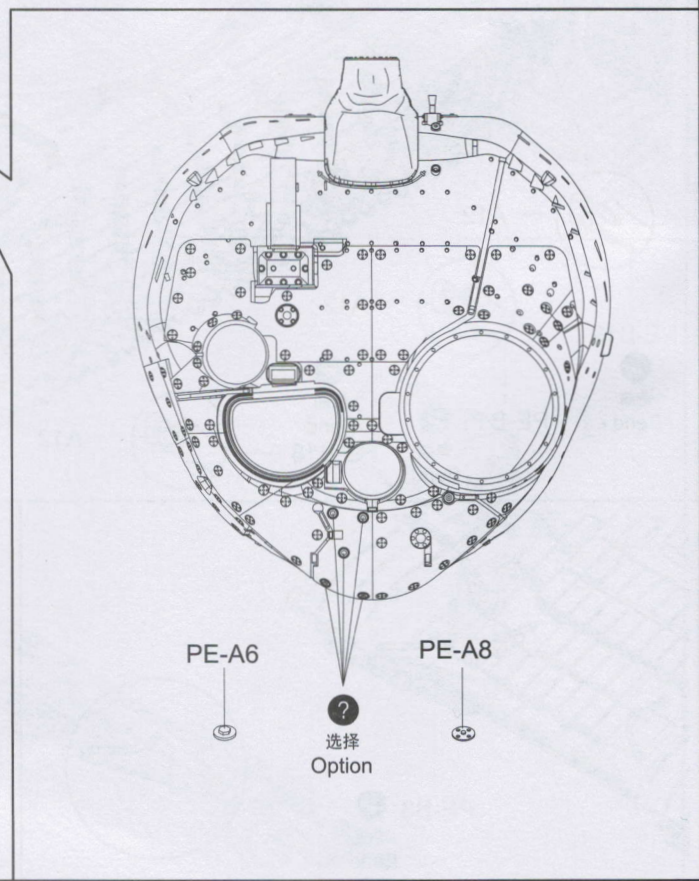
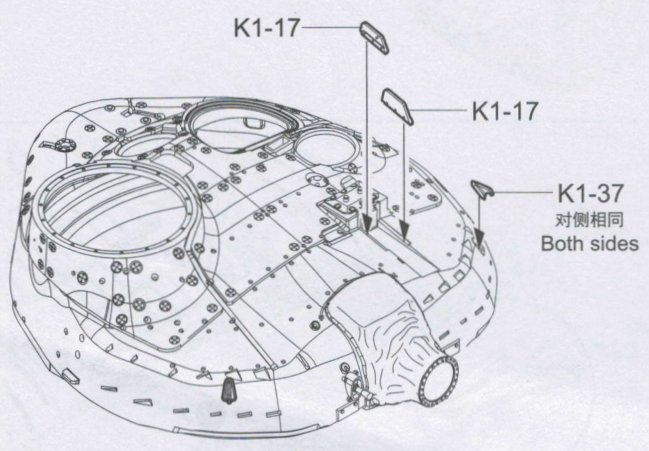
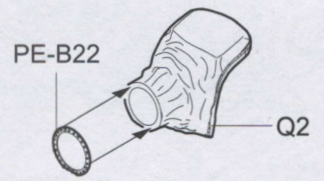
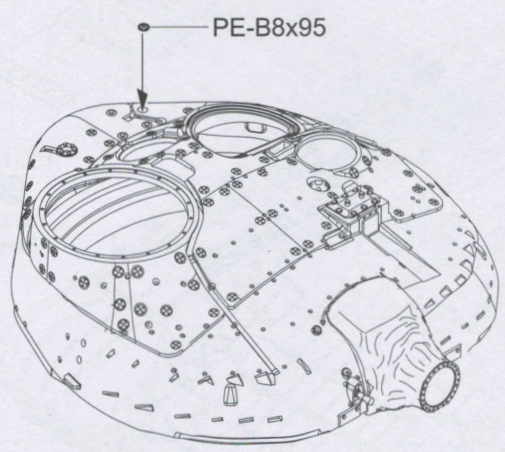
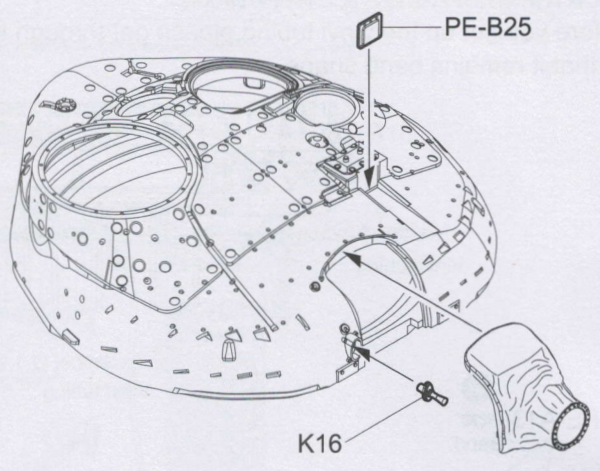
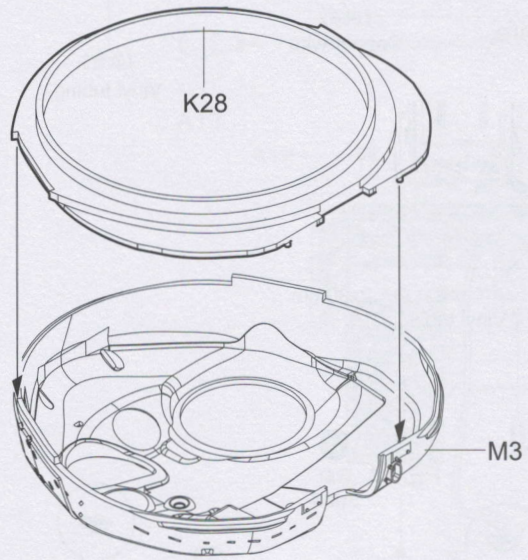



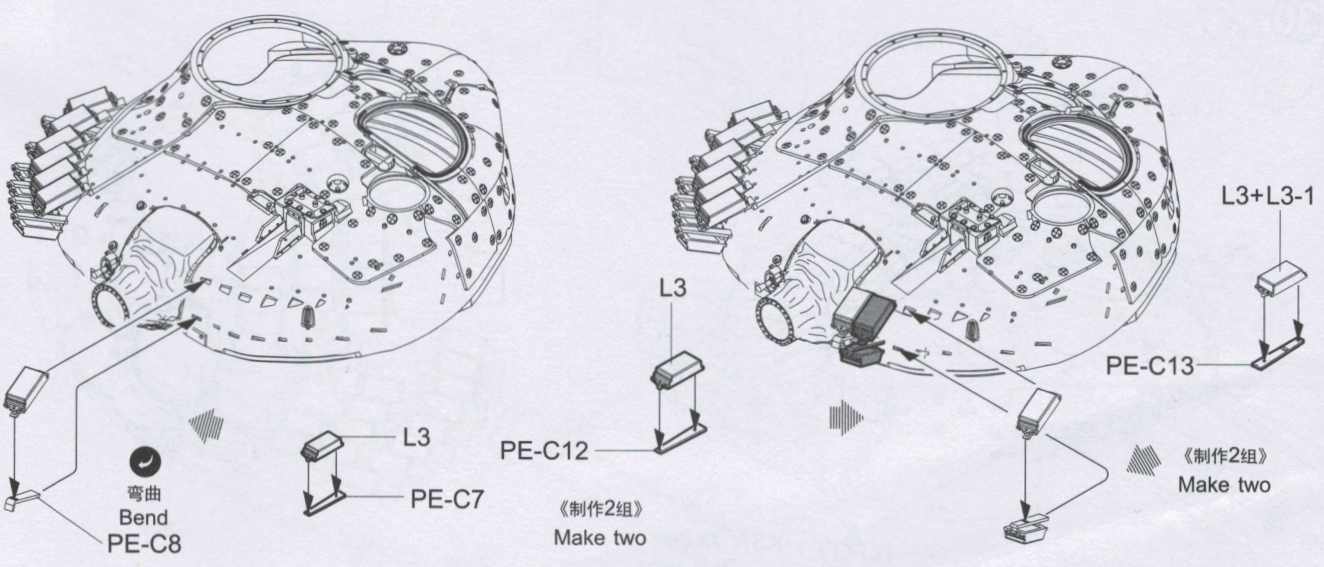
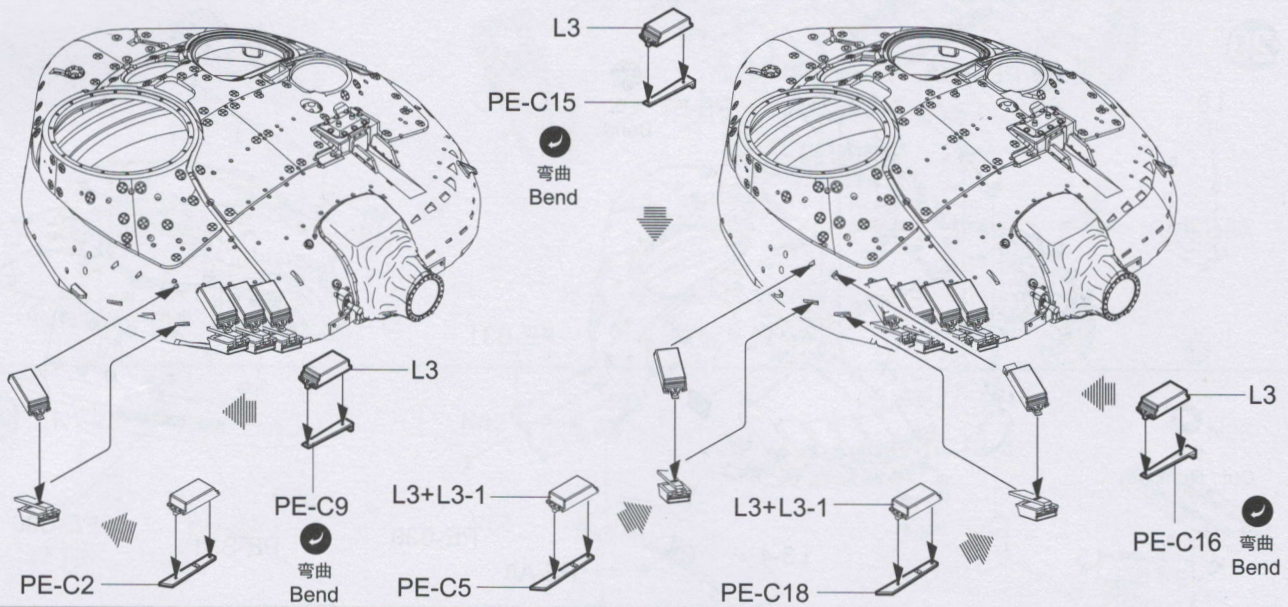
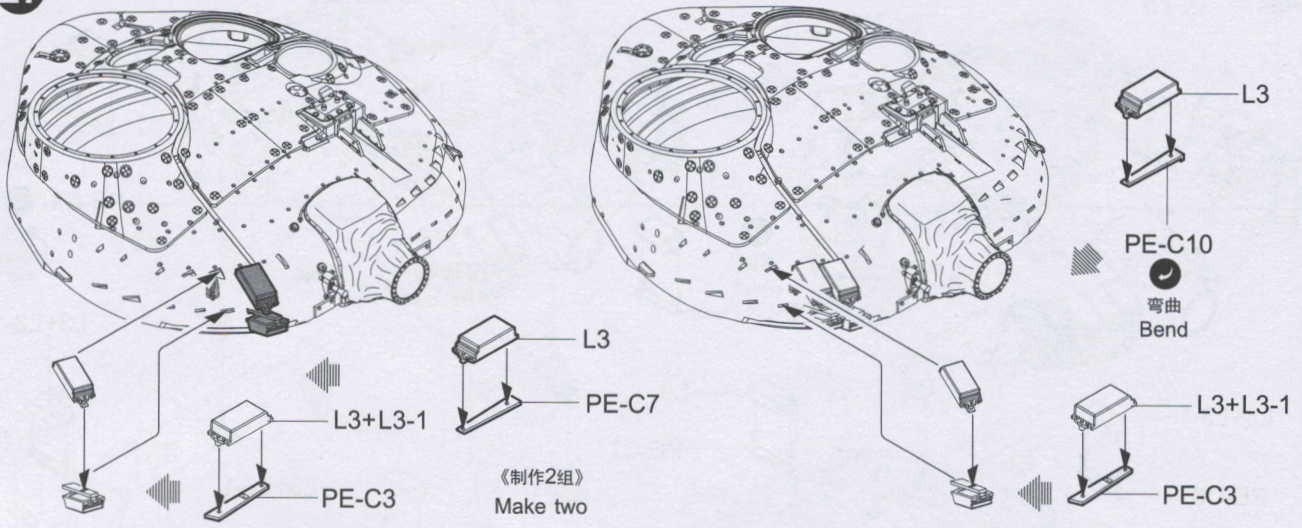



28

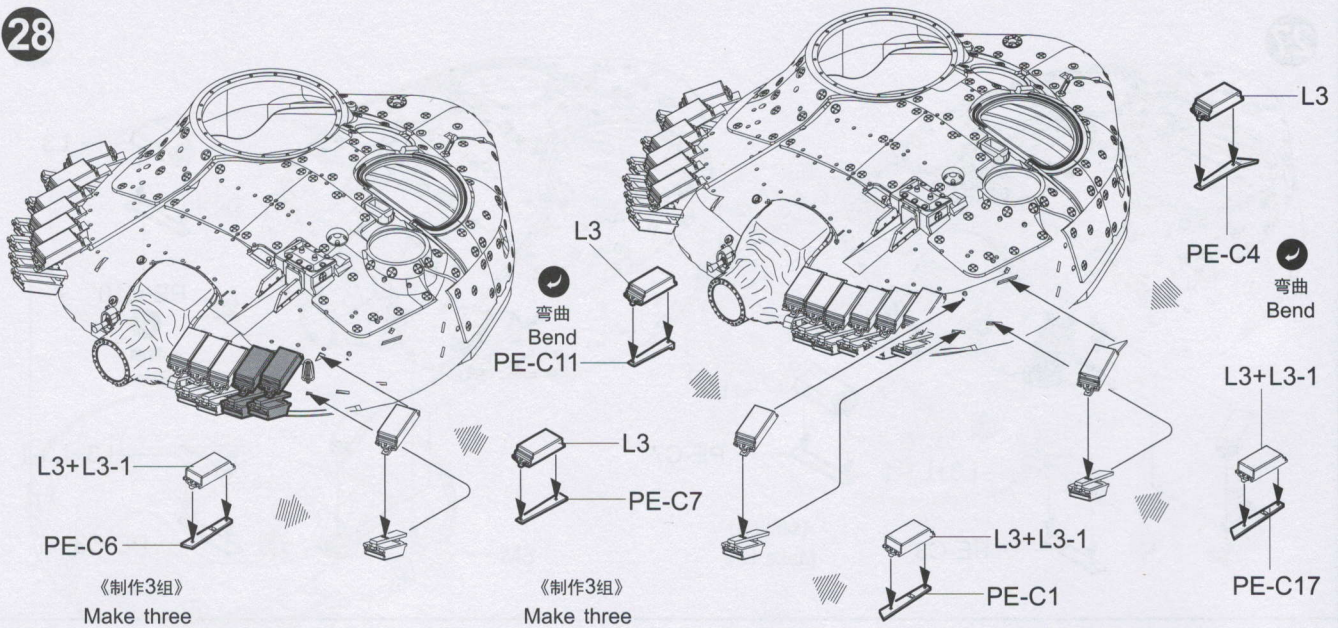

29

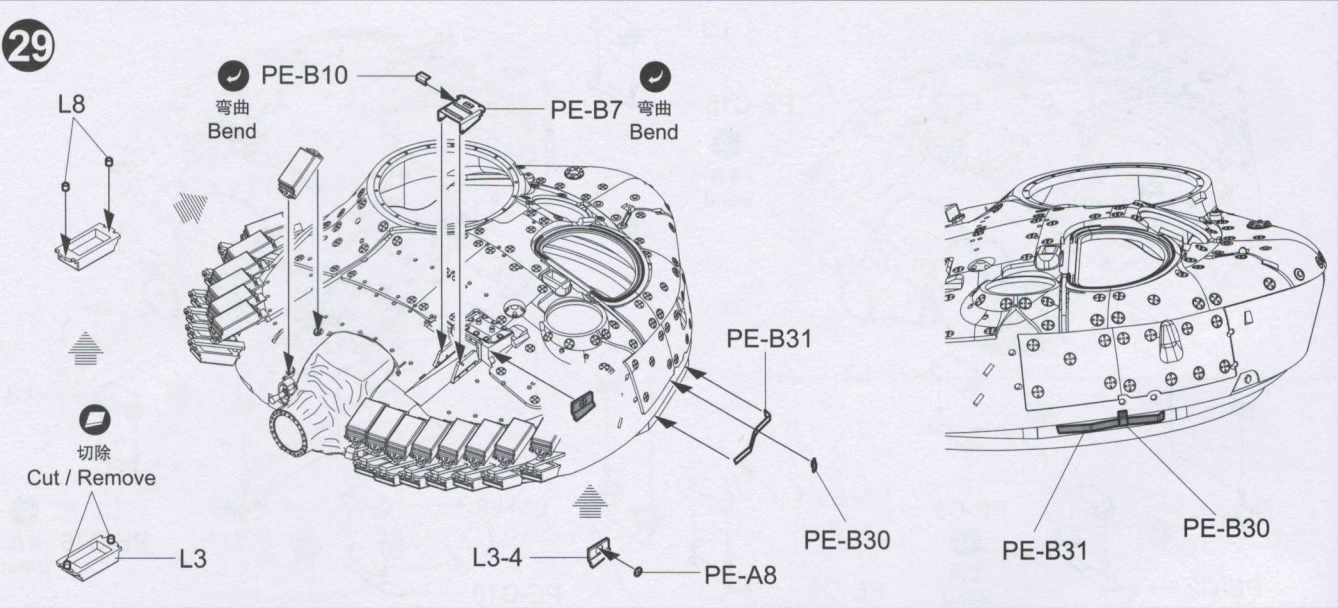

30

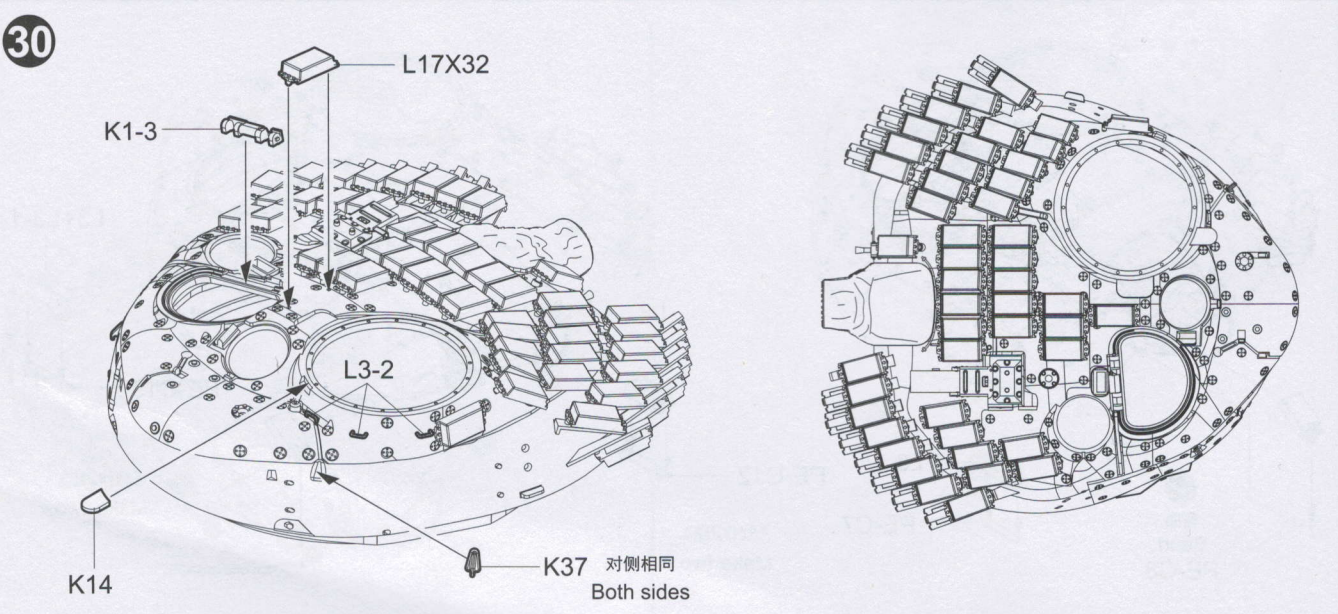



31

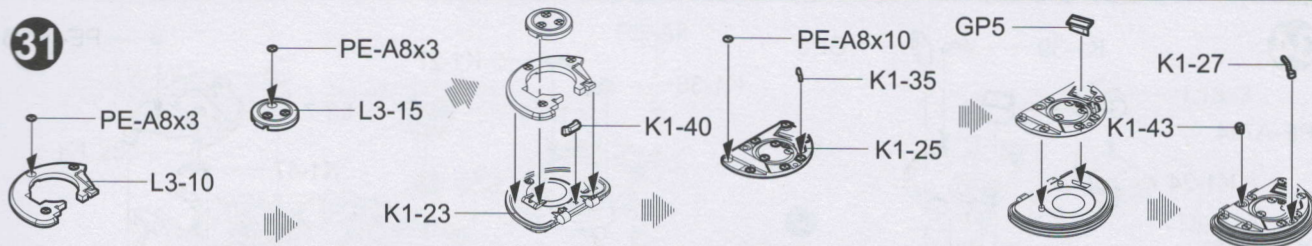

32

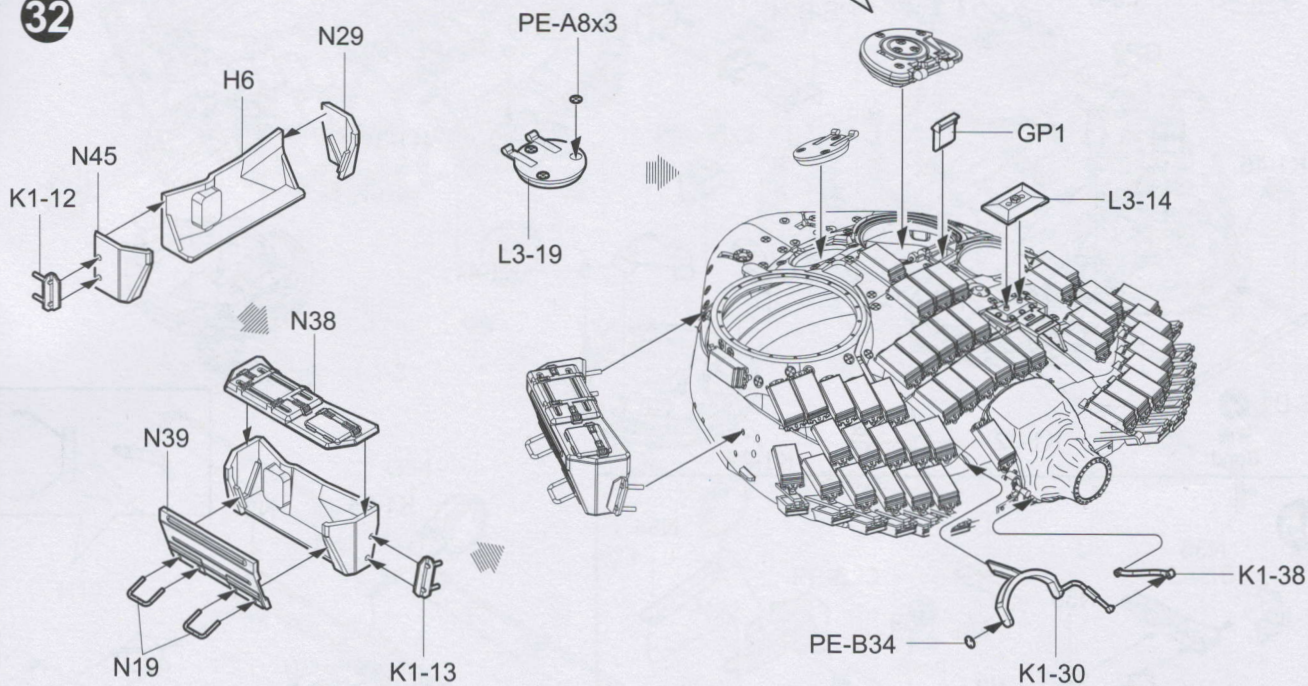

33

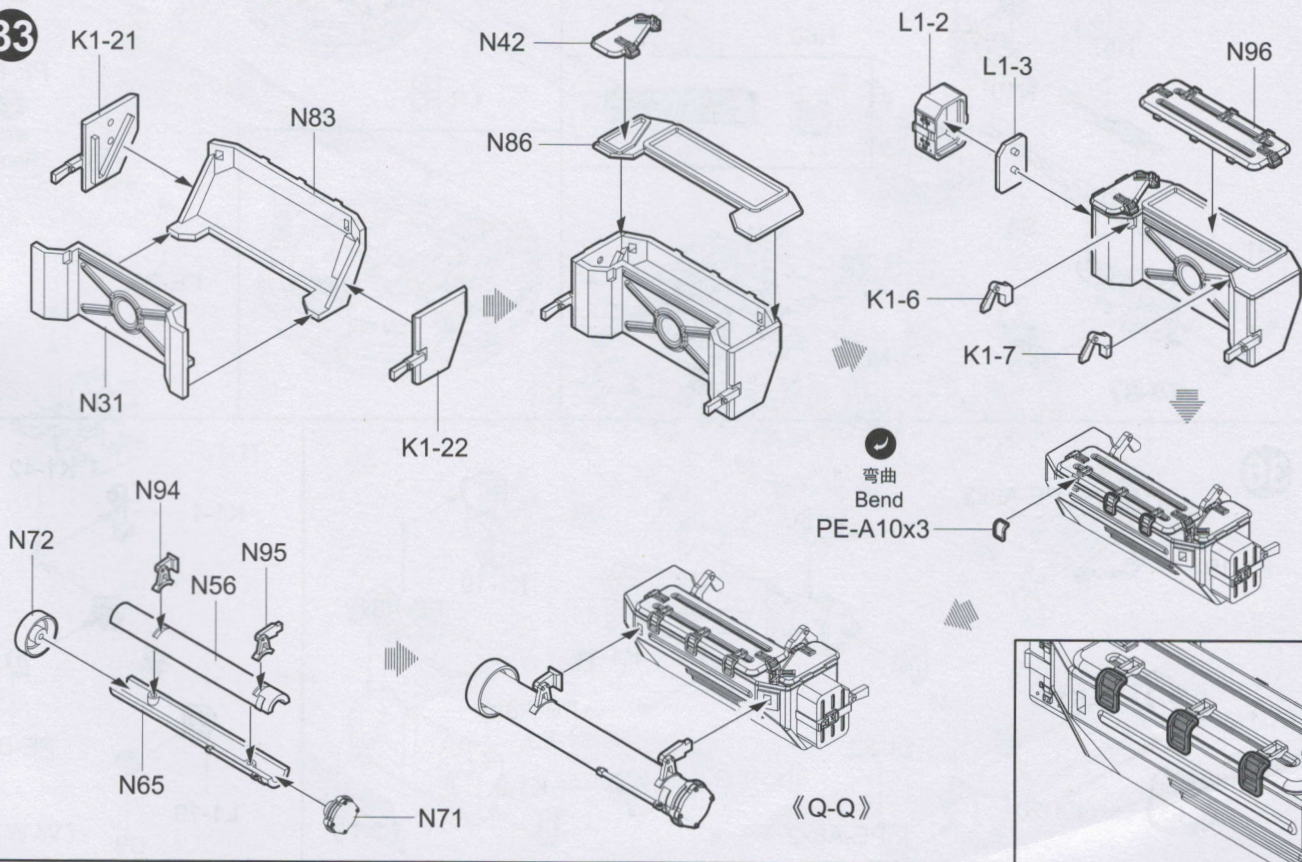



34

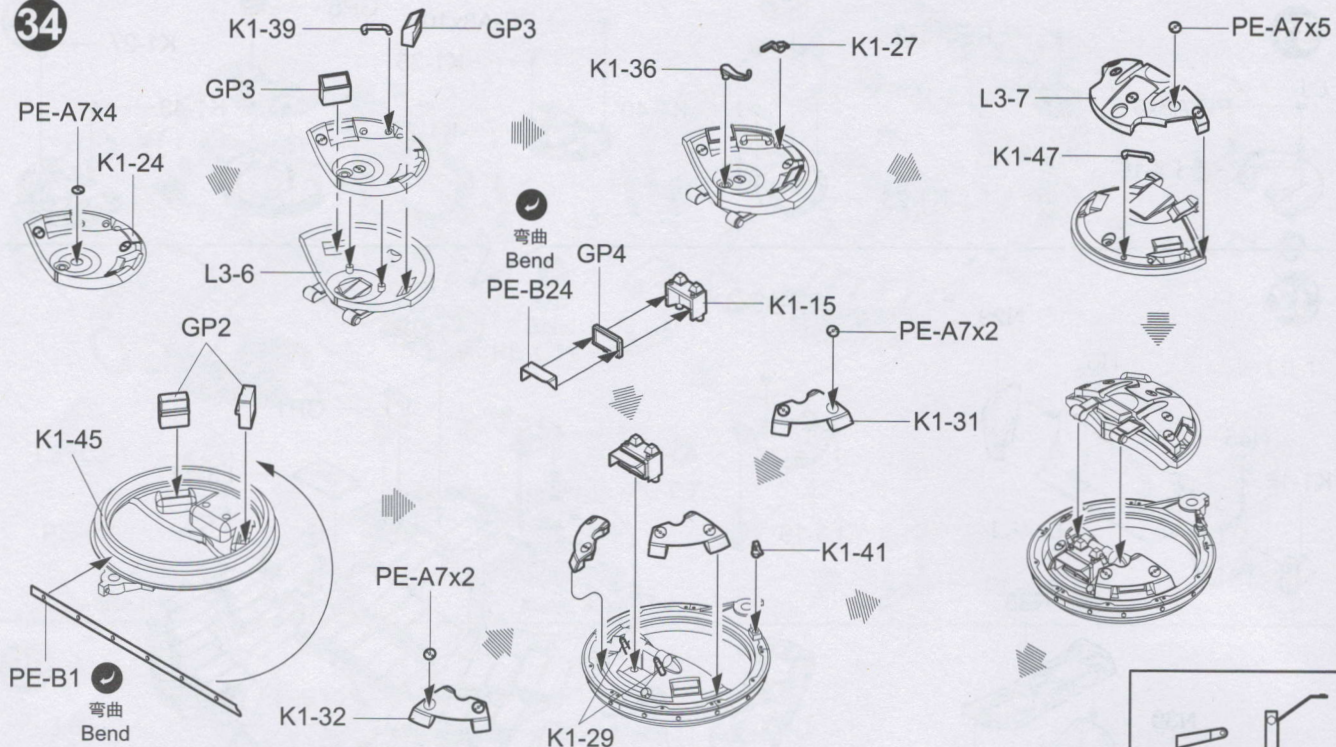

35

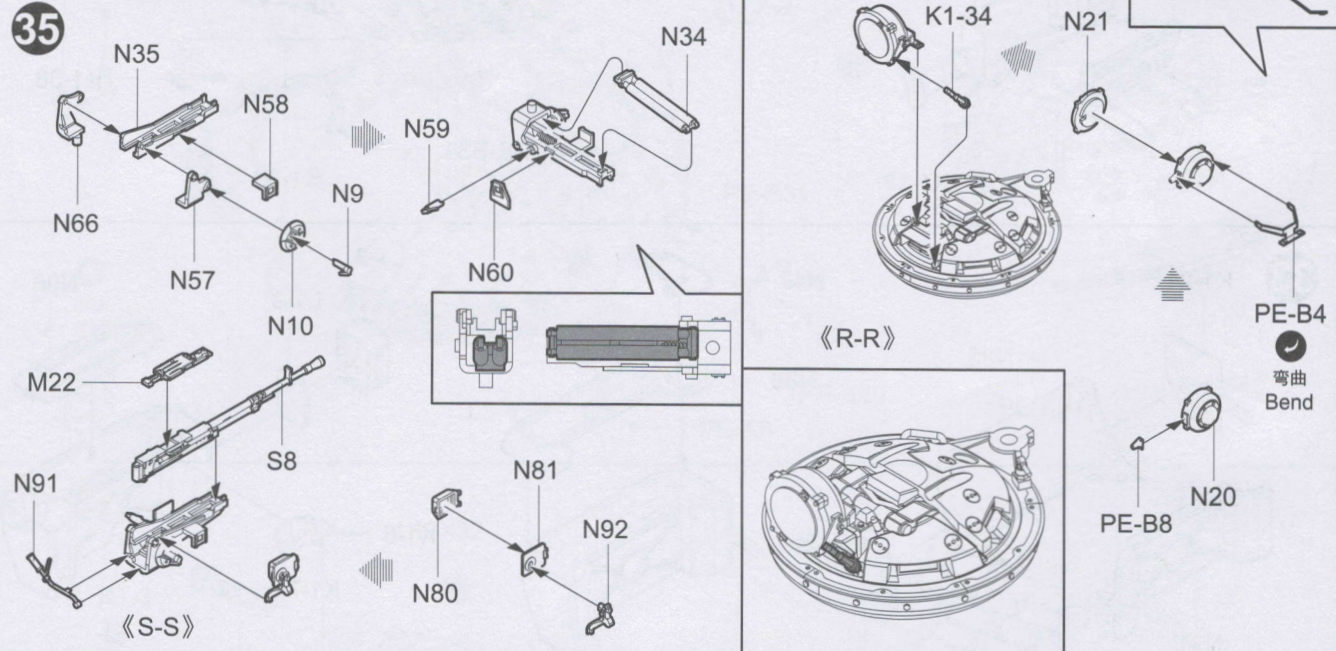

36

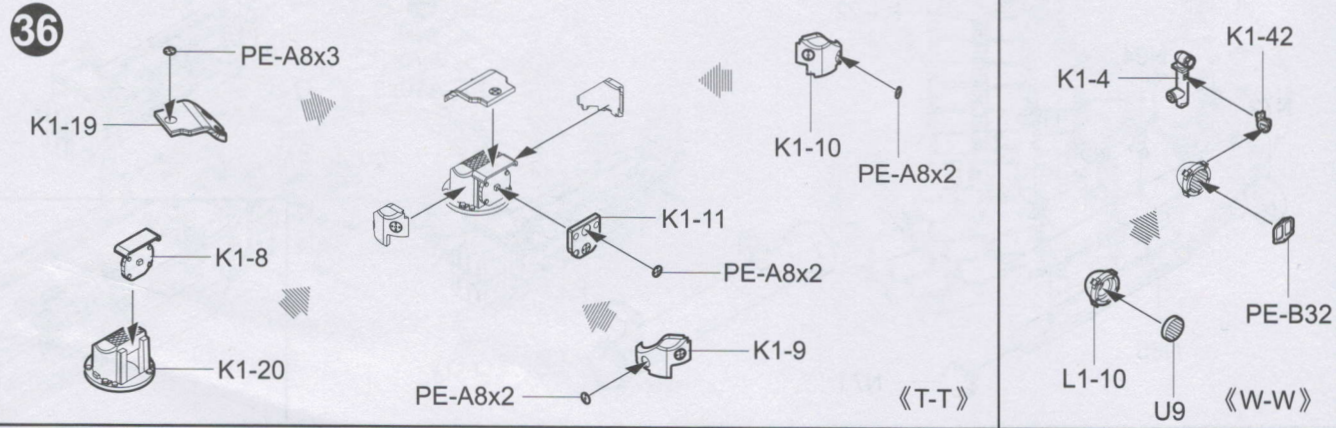



37

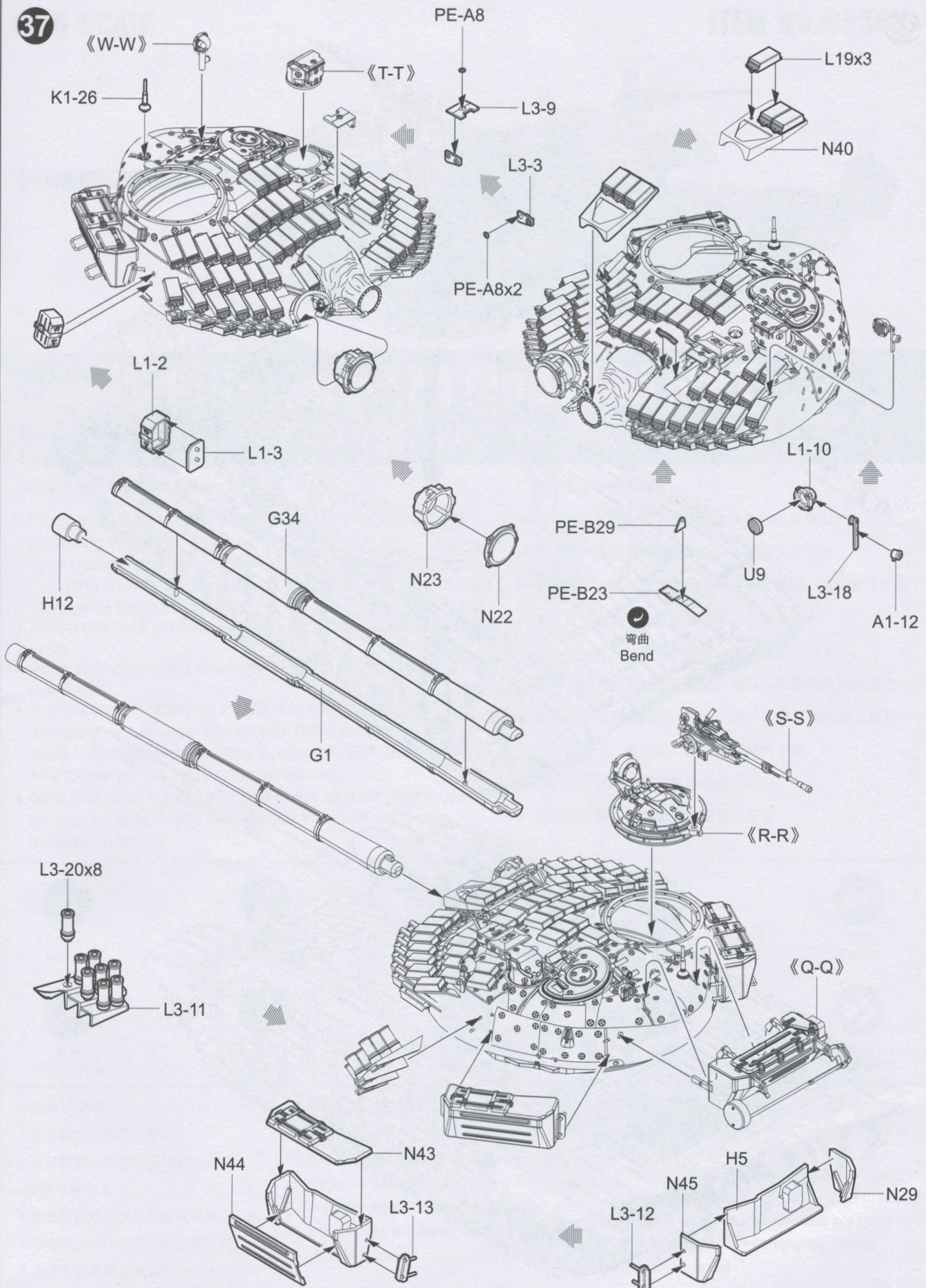



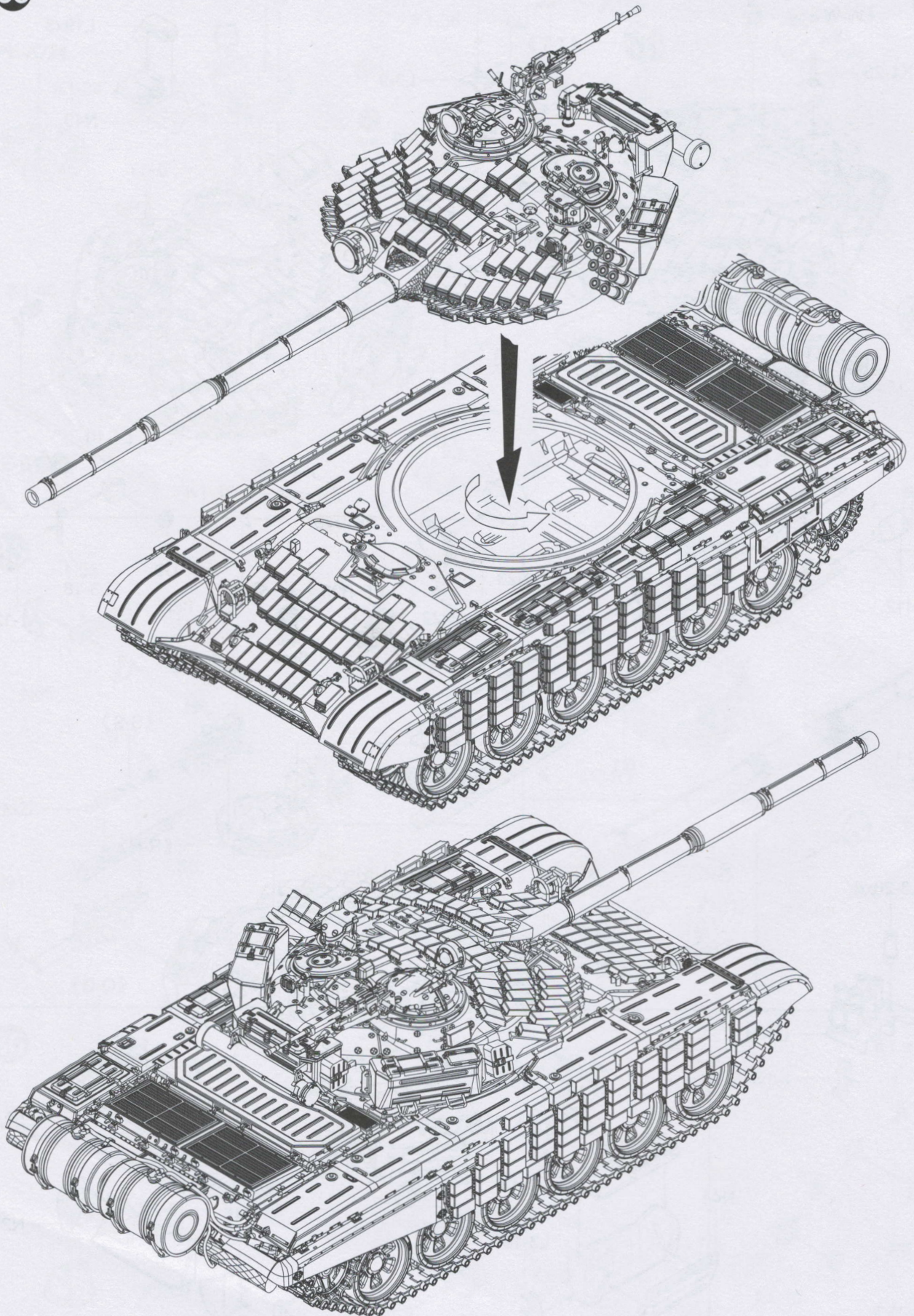



# 涂装同标贴指示 Painting & Marking guide

## PAINT REFERENCE COLOR

Color	Mr.Hobby	Acrysion	Vallejo	Model Master	Tamiya	Humbrol
Light Green 绿色	H 303 303	N 303	-	1713	XF20	117
Tire Black 胎黑色	H 77 137	N 77	-	-	-	-
Steel 黑铁色	H 18 28	N 18	864	1402	-	-

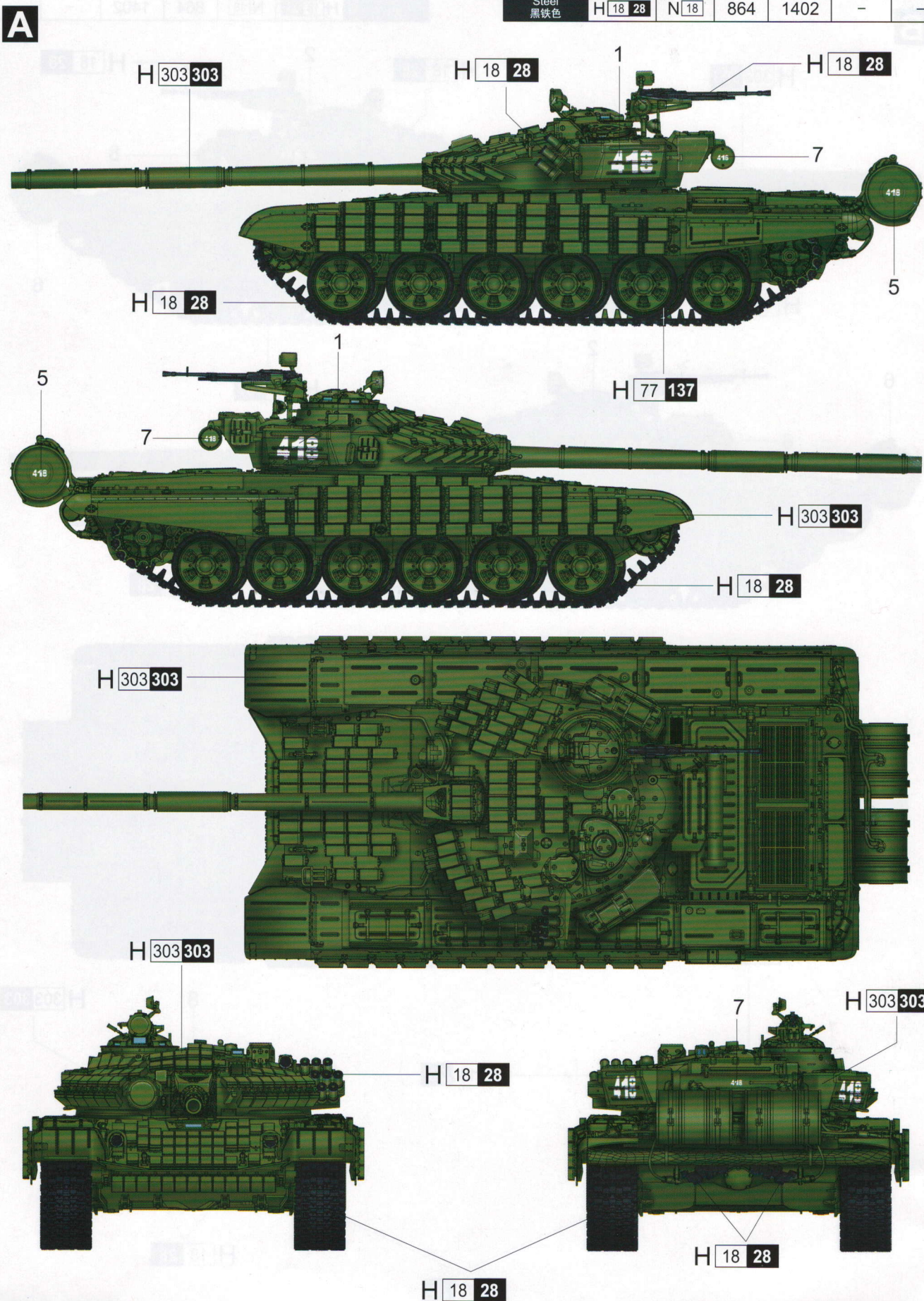

H  AQUEOUS HOBBY COLOR     Mr. COLOR  
N  ACRYSION COLOR



# 涂装同标贴指示 Painting & Marking guide

## PAINT REFERENCE COLOR

Color	Mr.Hobby	Acrycion	Vallejo	Model Master	Tamiya	Humbrol
Light Green 绿色	H 303 303	N 303	-	1713	XF20	117
Tire Black 胎黑色	H 77 137	N 77	-	-	-	-
Steel 黑铁色	H 18 28	N 18	864	1402	-	-

**B**

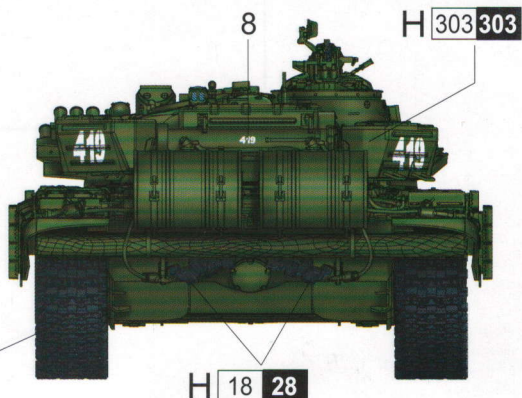
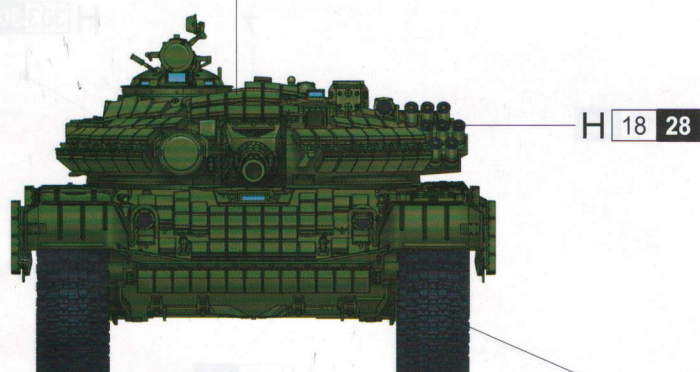
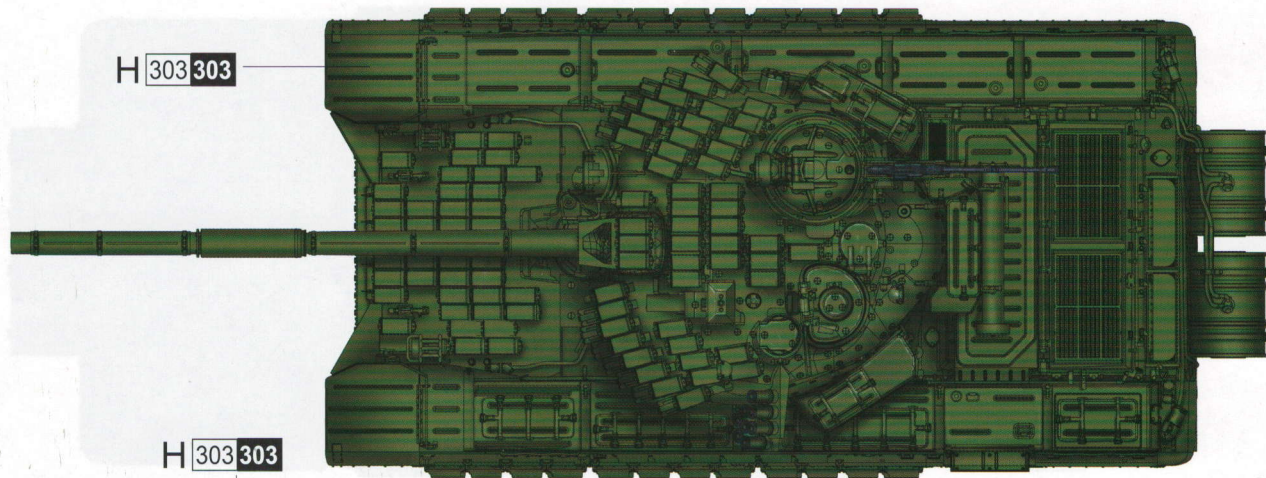
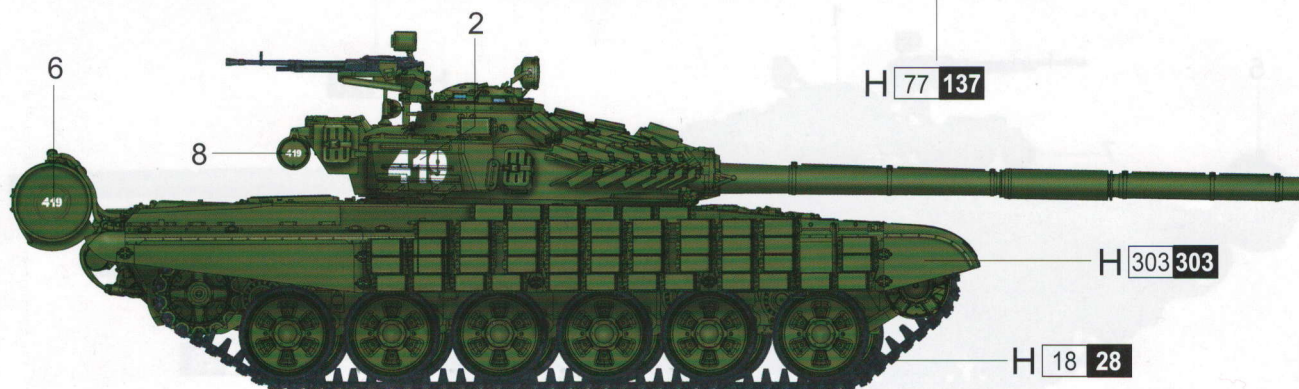
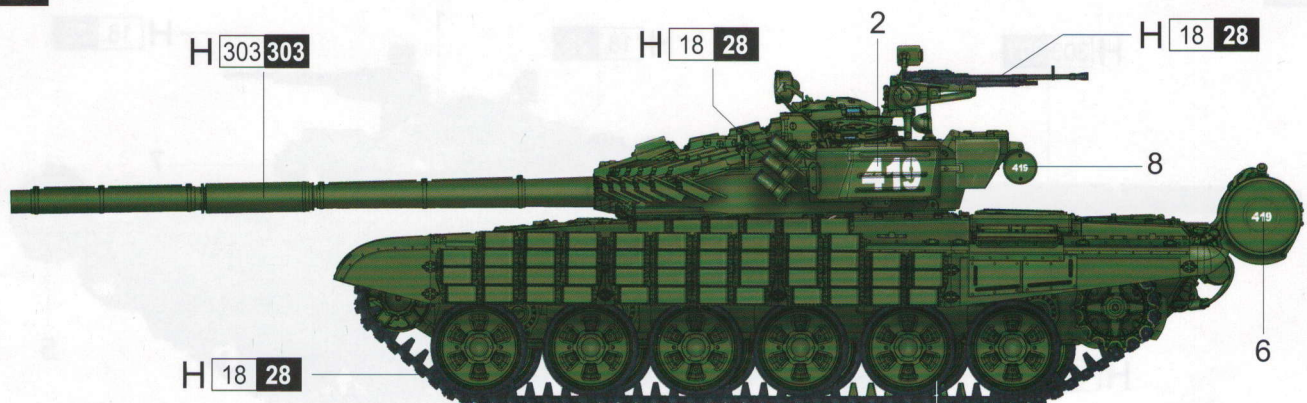

H 18 28

H  AQUEOUS HOBBY COLOR     Mr. COLOR  
N  ACRYSION COLOR