



Antonov An-24B

PLASTIC MODEL KITS
LIMITED EDITION
CAT.NO. 72356



SPAN : 406 mm
LENGTH : 331 mm
PARTS : 159 pieces
SCALE:1/72



Due to the fact that Il-14 piston engine aircraft had to be replaced by the same aircraft class with turbo engines, in 1957, OKB Antonov (Antonov Design Bureau) proposed to design a new aircraft on short to medium haul trips and with possibility to operate from small unprepared airports. Its performances and power plant provided the operation in high mountains and in a wide range of temperatures. The An-24 prototype made its maiden flight on April 20, 1960. In 1962, serial aircrafts were put into Aeroflot service. In 1963, the first 50-seat An-24V aircrafts started to flight between Moscow, Voronezh and Saratov

Next versions are: An-24V Series II - 50-seat mixed passenger, cargo and freight version; An-24RV - similar to the previous version, but fitted with a 1,985-lb (900-kg) thrust auxiliary turbojet engine for engine independent starting and for increasing the power to weight ratio at take off; An-24T - freight transport version with a cargo door in the tail fuselage, two ventral fins from the exterior of the cargo door, overhead-track hoist and airdrop equipment; An-24RT - similar to the An-24T, but fitted with an auxiliary turbojet engine as on the An-24RV; An-24LP-forest fireproof version. Totally, 1100 An-24 aircrafts for civil and military operations were produced.

The model is executed on technology short run and is intended only for experienced modelers!
World-wide distributor for AMODEL kits : IBG, Warszawa, Poland
Fax:(4822)842-56-29 , E-Mail:ibgsc@ibg.com.pl

Модель виконана за технологією Short run і призначена лише для досвідчених модельєрів
Дистриб'ютор моделей AMODEL : IBG, Варшава, Польща
Факс:(4822) 842-56-29 ; E-Mail:ibgsc@ibg.com.pl



USED SYMBOLS / ВИКОРИСТОВУВАНІ СИМВОЛИ



STAGES OF ASSEMBLY
ЕТАПИ СКЛАДАННЯ



NUMBER PARTS
НОМЕР ДЕТАЛІ



APPLY DECALS
НАКЛЕЙТИ ДЕКАЛЬ



TO PAINT
ЗАБАРВИТИ



GLUE
КЛЕЇТИ



DON'T GLUE
НЕ КЛЕЇТИ



OPTIONAL
НА ВИБІР



MAKE A HOLE
ВИКОНАТИ ОТВІР



DETACH WITH KNIFE
ВІДКРЕМИТИ
НОЖЕМ



QUANTITY OF OPERATIONS(PARTS)
КІЛЬКІСТЬ ОПЕРАЦІЙ (ДЕТАЛЕЙ)

DECALS FOR TWO VERSIONS OF COLOURING
ДЕКАЛЬ ДЛЯ ДВОХ ВАРІАНТІВ ФАРБУВАННЯ

159 DETAILS FOR ASSEMBLY OF ONE MODEL
159 ДЕТАЛЕЙ ДЛЯ ЗБИРАННЯ ОДНІЄЇ МОДЕЛІ

PARTS NOT FOR USE
ПРИ СКЛАДАННІ НЕ ВИКОРИСТОВУЄТЬСЯ

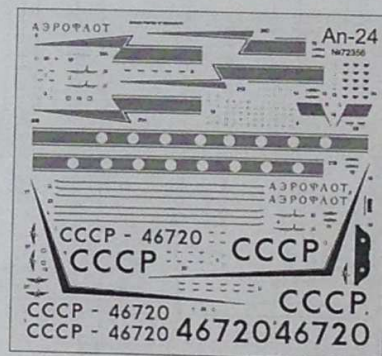

USED PAINTS / ВИКОРИСТОВУВАНІ ФАРБИ



HUMBROL 147
LIGHT GREY
СВІТЛО СІРИЙ



HUMBROL 27002
POLISHED ALUMINIUM
ПОЛ. АЛЮМІНІЙ



HUMBROL 27003
POLISHED STEEL
ПОЛІР. СТАЛЬ



HUMBROL 33
BLACK
ЧОРНИЙ



HUMBROL 24
YELLOW
ЖОВТИЙ



HUMBROL 87
STEEL GREY
СТАЛЕВ. СІРИЙ



HUMBROL 101
MID GREEN
СЕРЕД. ЗЕЛЕНИЙ



HUMBROL 27004
GUN METAL
МЕТАЛЕВИЙ



HUMBROL 34
WHITE
БІЛИЙ

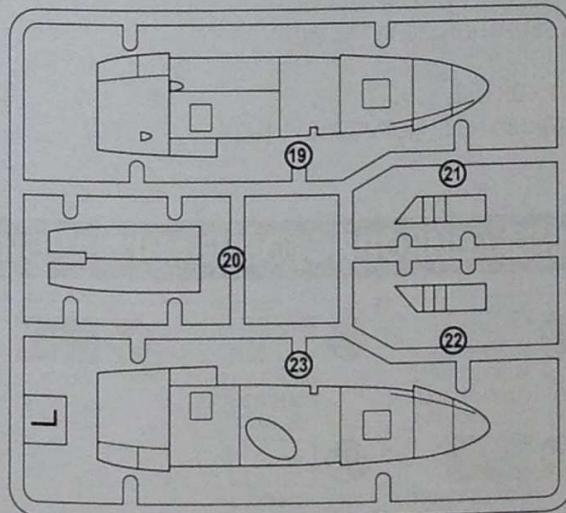
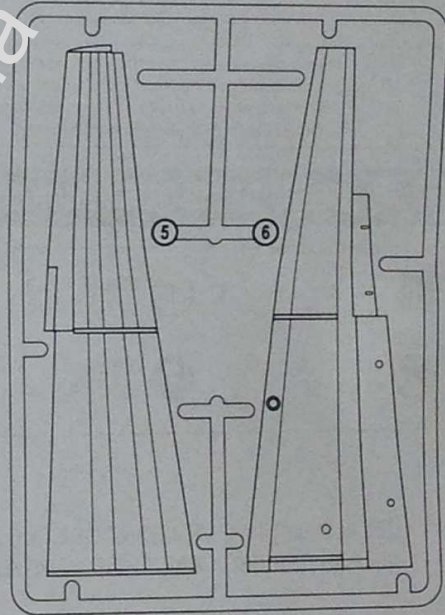
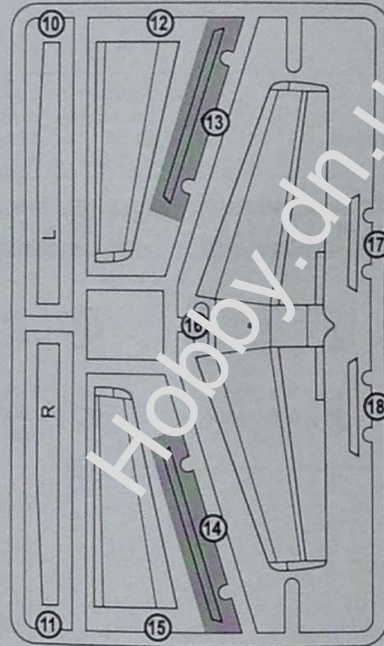
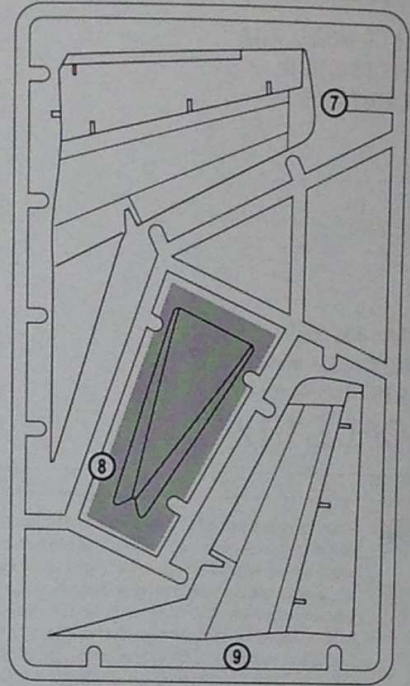
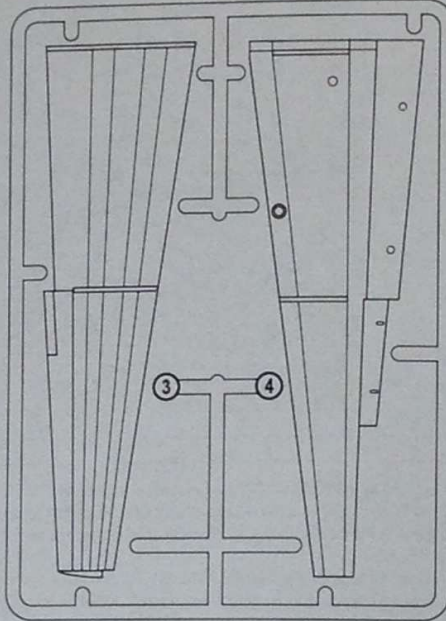
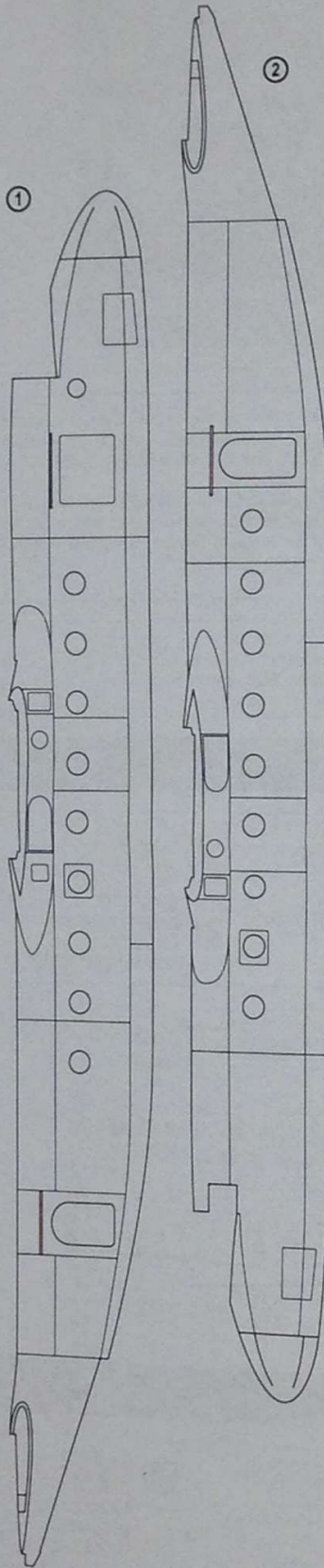

Hobby.dn.ua

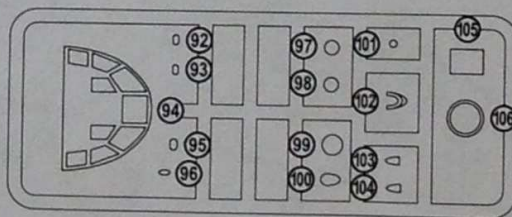
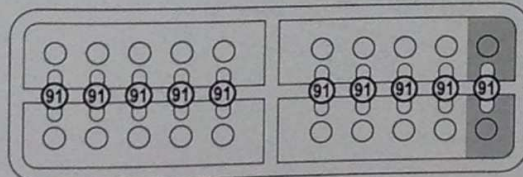
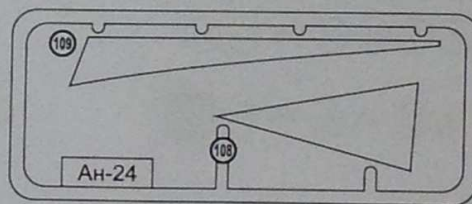
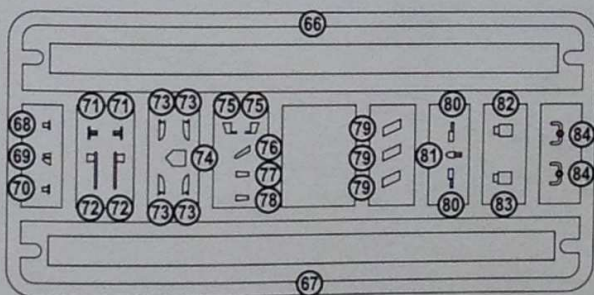
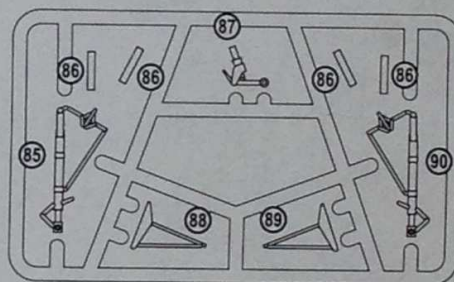
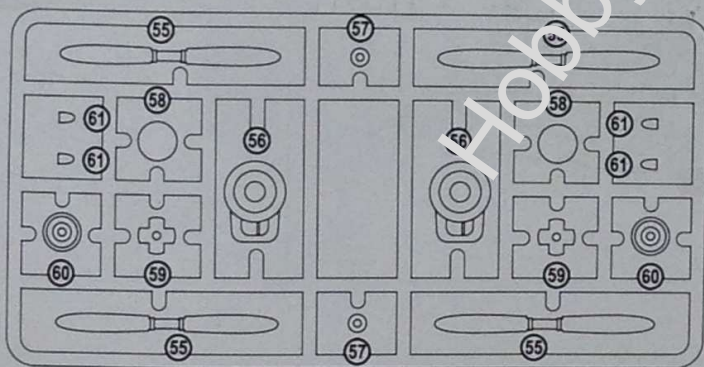
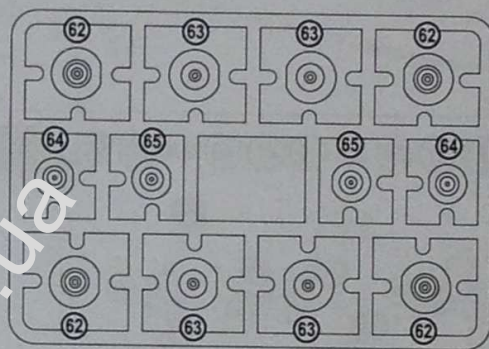
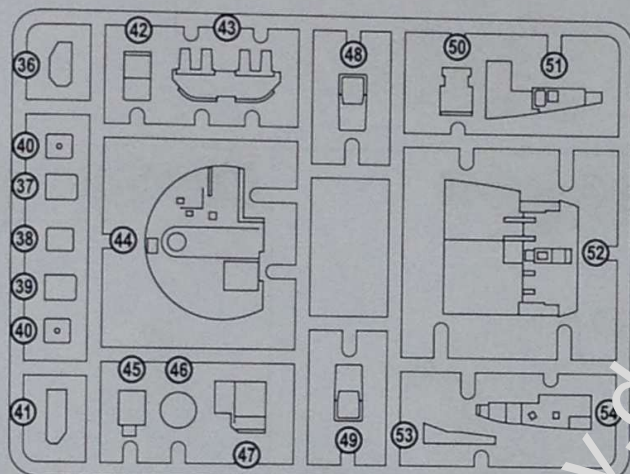
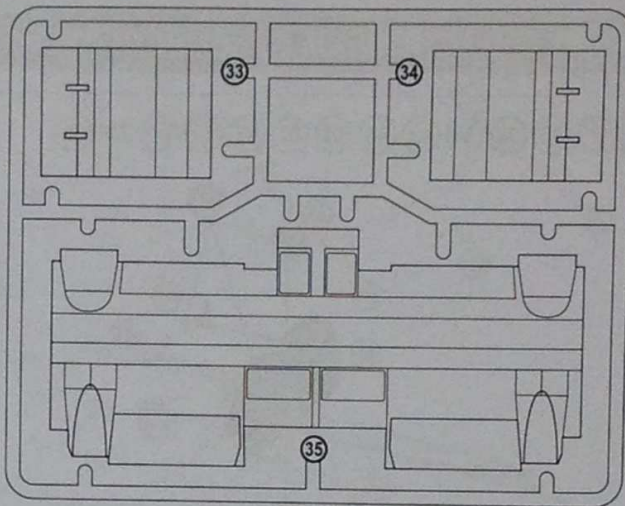
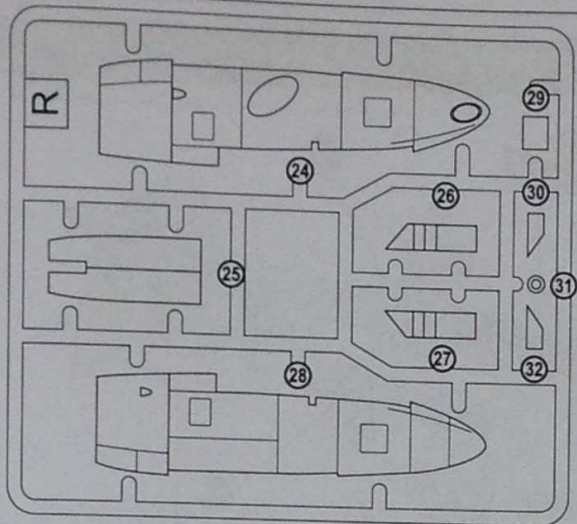

1 36 38 41 43 44 51 52 53 54 83 2x 84

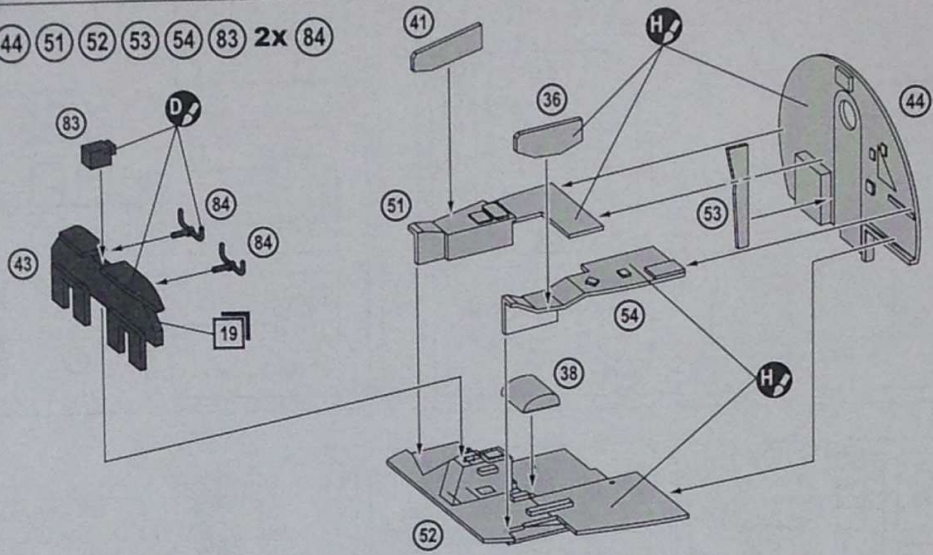

2 37 39 2x 40 48 49 2x 80 1

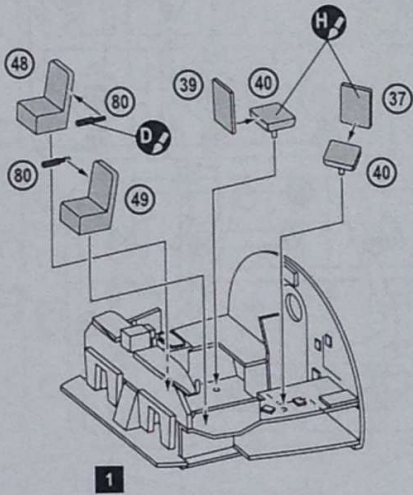

3 42 47 74 82 2

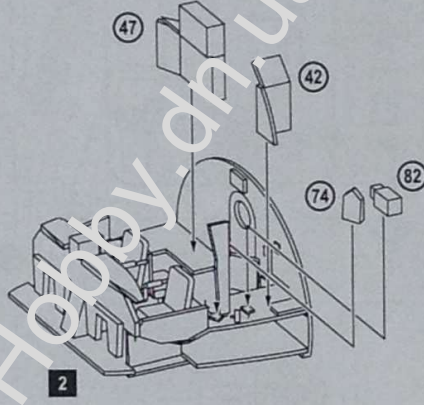

4 50 94



5 1 45 66 9x 91 99

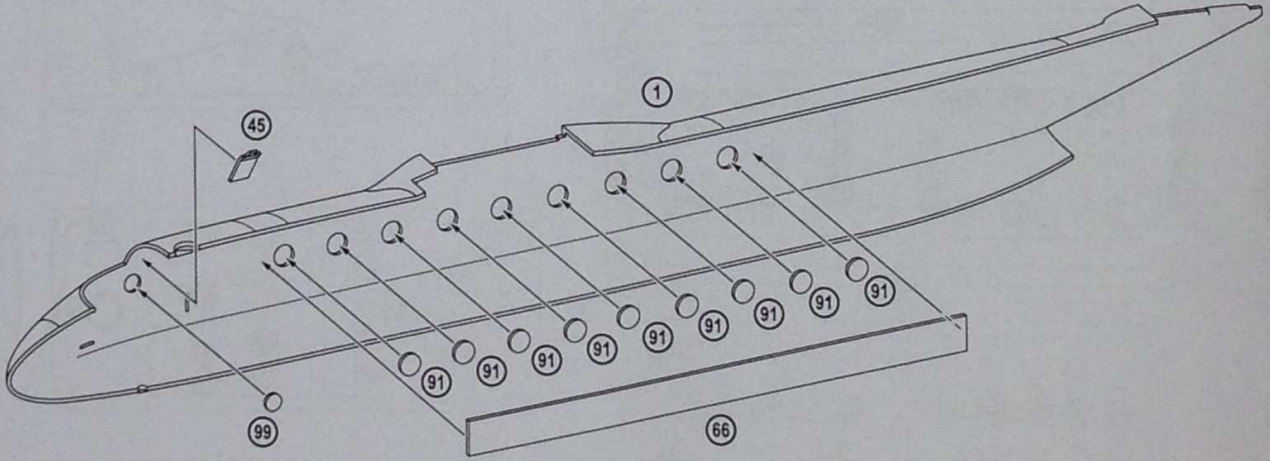

6  2 67 9x 91 92 93 95

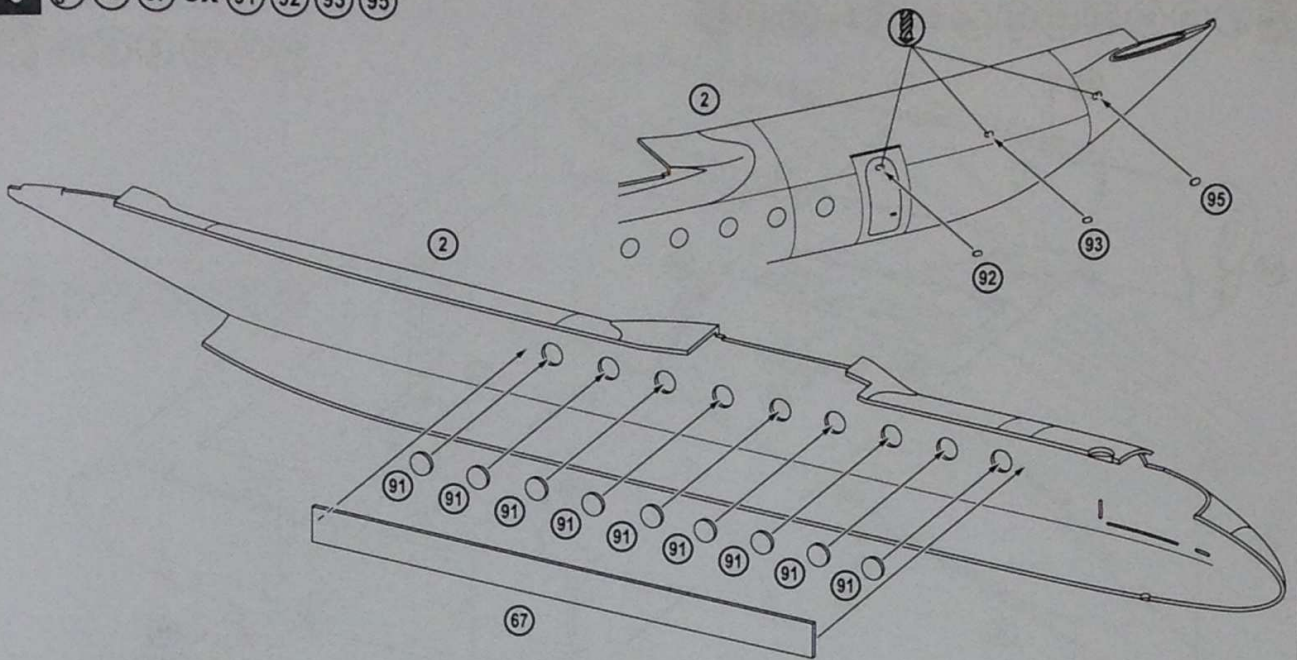

7  12 15 16

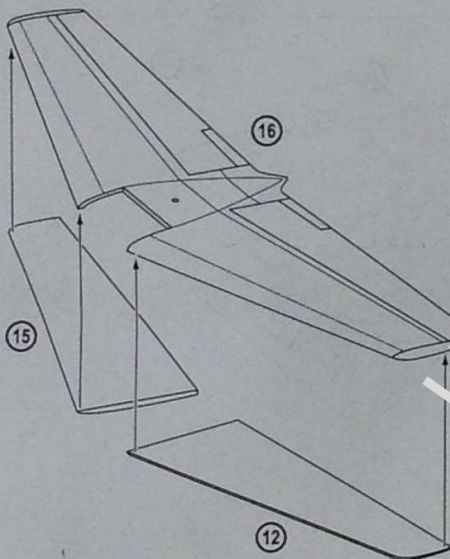

8  7 9 101 102

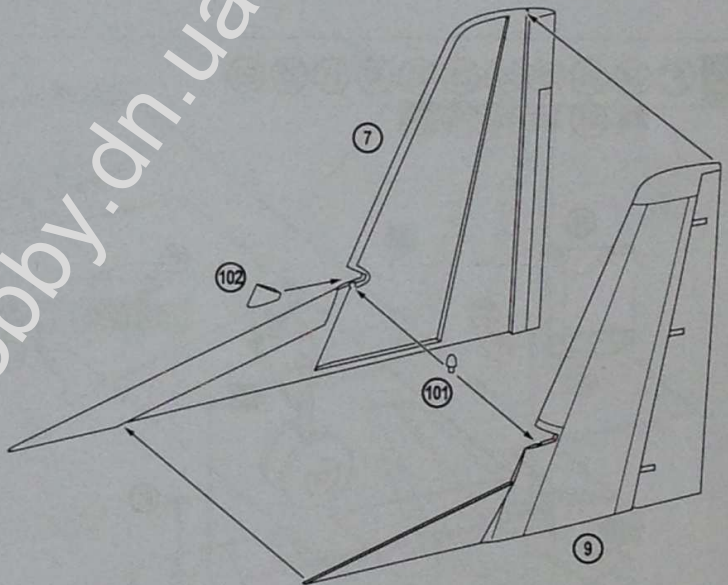

9  2x 62 2x 63 85

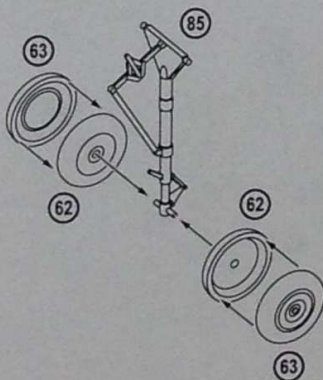

10  2x 62 2x 63 90

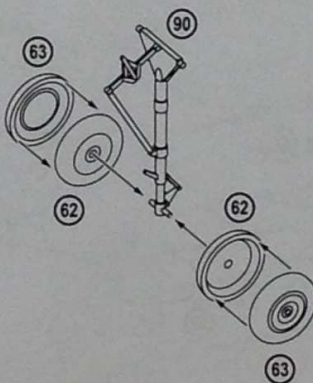

11  2x 64 2x 65 87

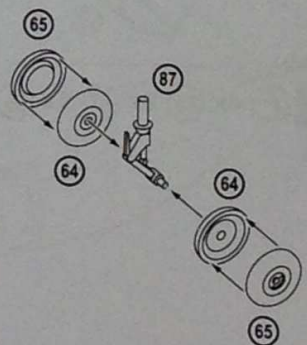

12 19 20 21 22 23 56 2x 61 2x 86 88 9

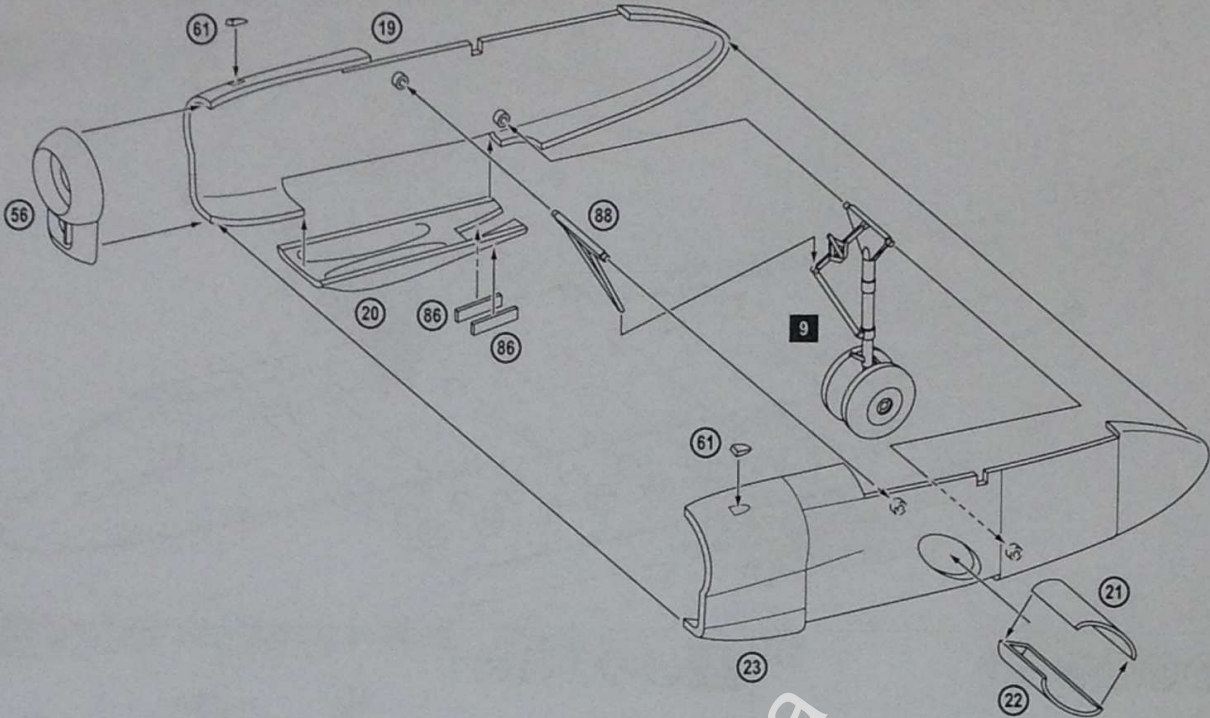

13 24 25 26 27 28 29 30 31 32 56
2x 61 2x 86 89 10

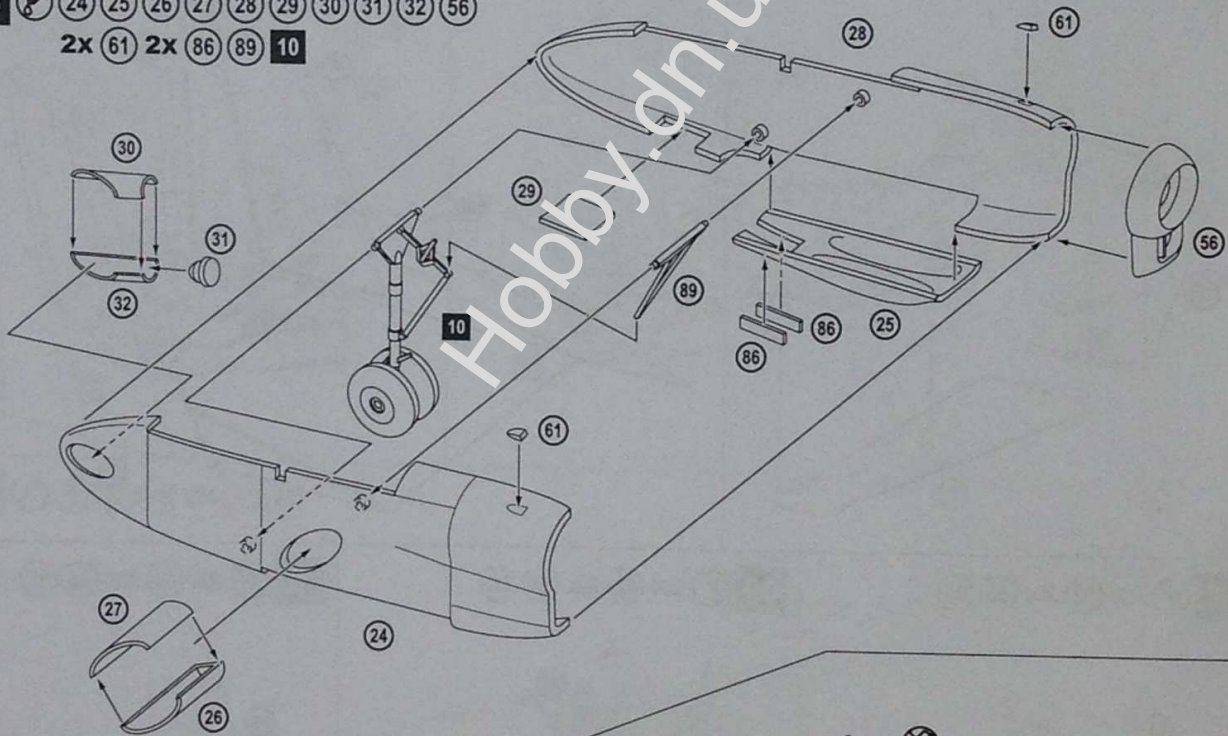

14 4x 55 2x 57 2x 58 2x 59 2x 60
2X

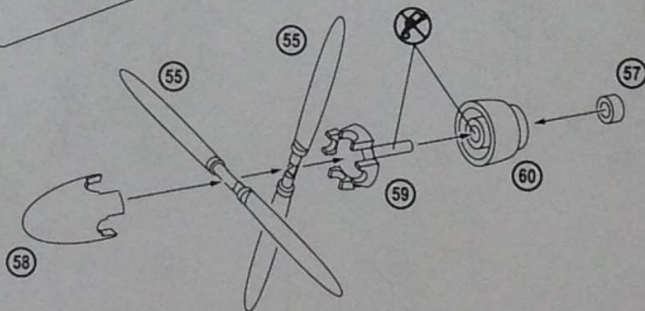

15 5 6 77 97 103

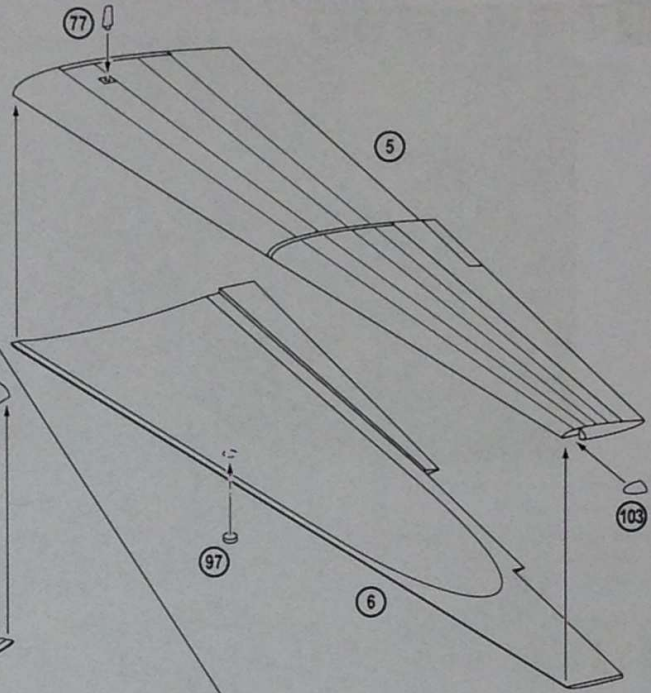

16 3 4 78 98 104

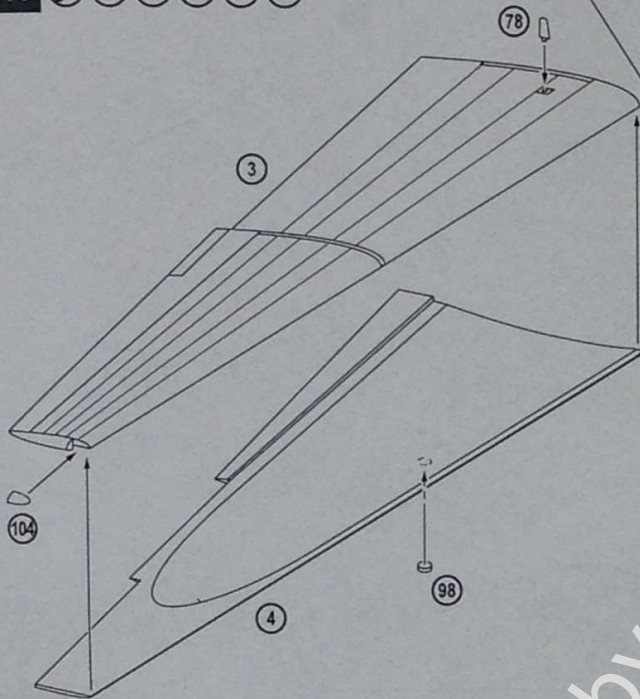

17 10 11 33 34 35 46 96 105 106 3 4 5 6 7 8

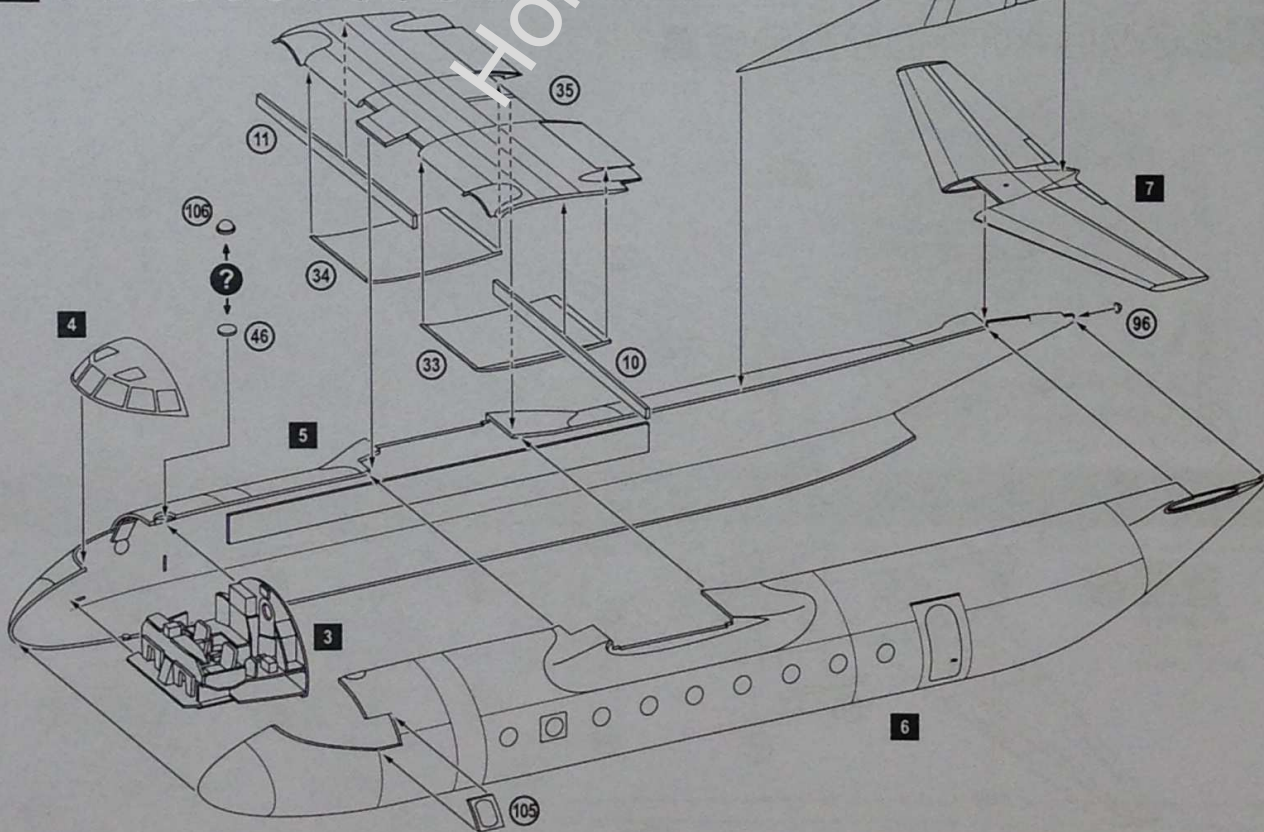

18  11 12 13 15 16 17

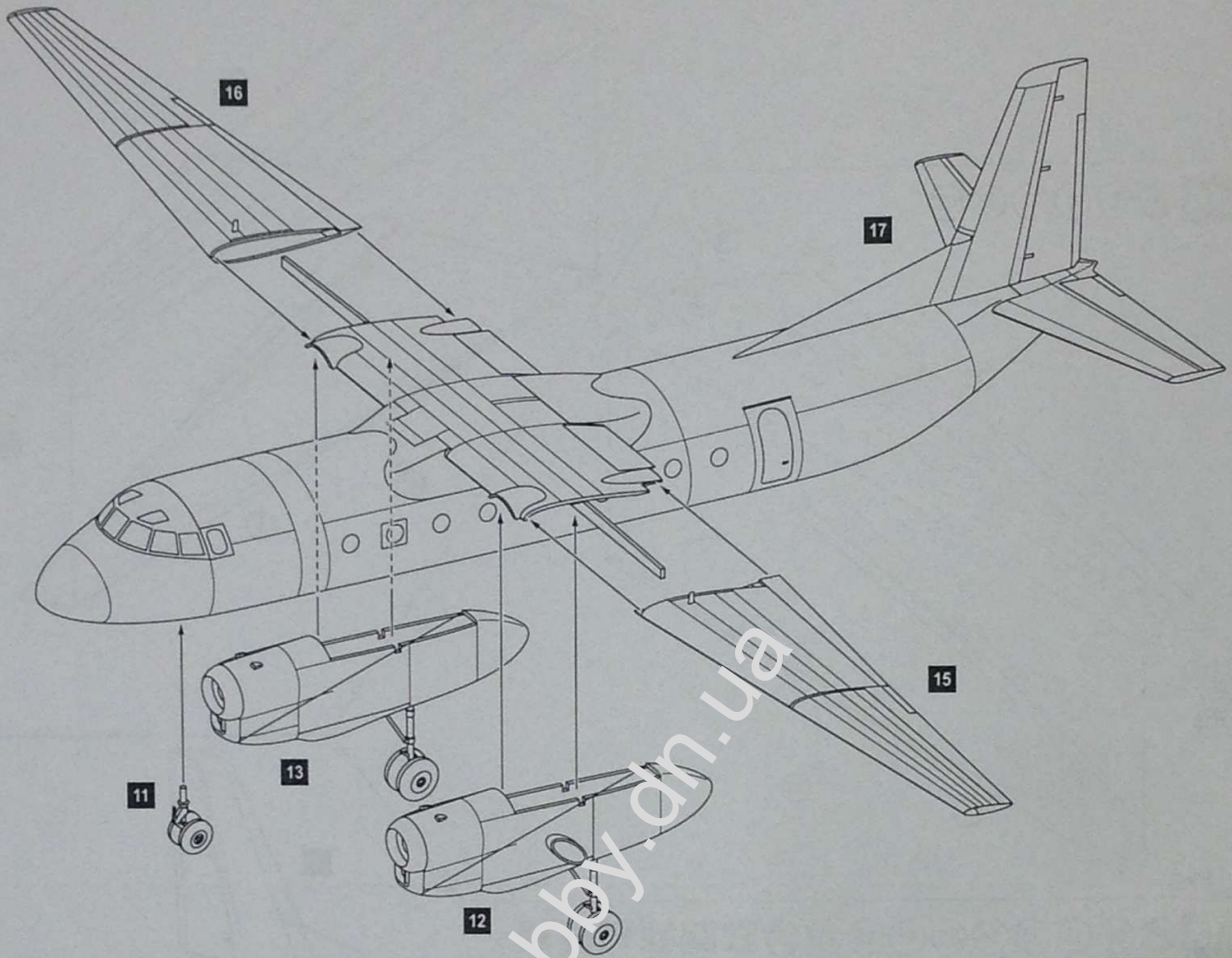

19  8 17 18 2x 71 4x 73 79 100 108 109 18

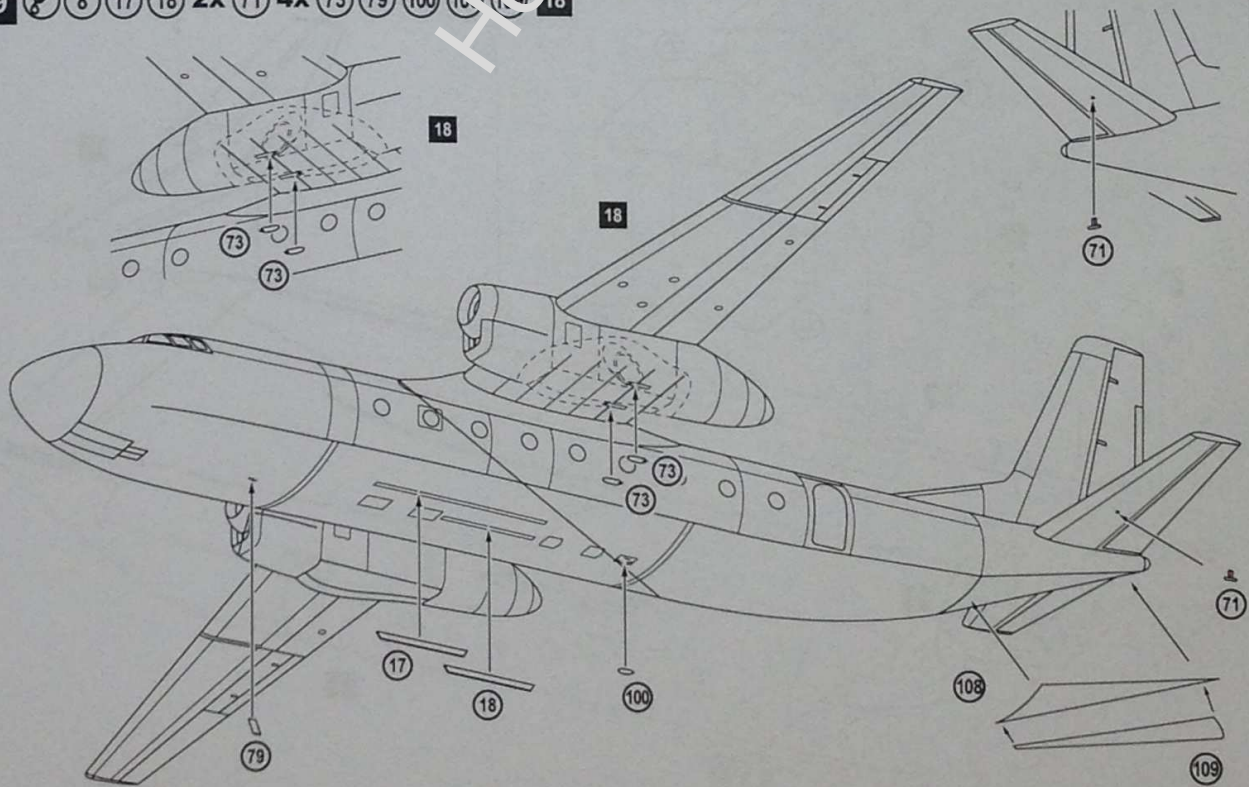

20  69 70 72 75 76 19

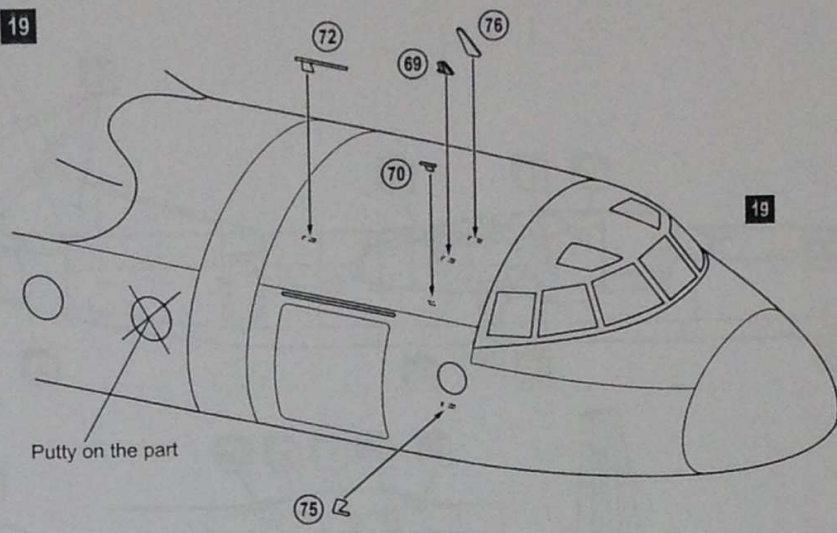

21  68 72 75 79 81 20

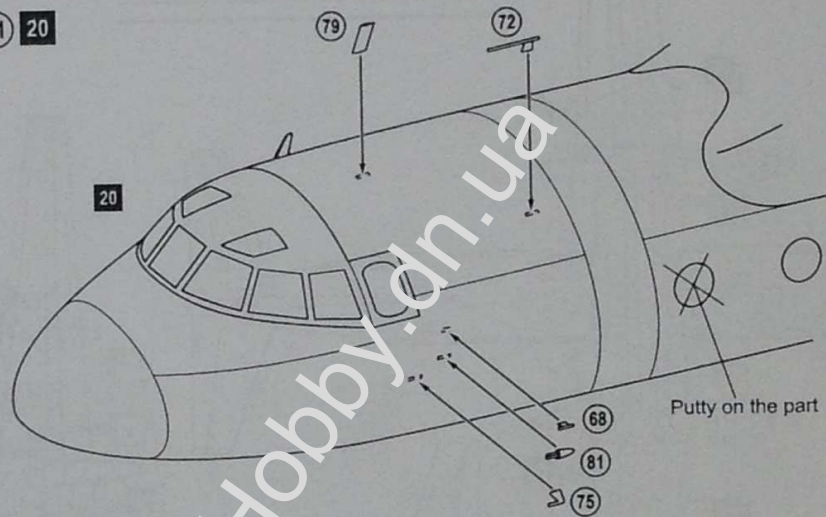

22  2x 14 21

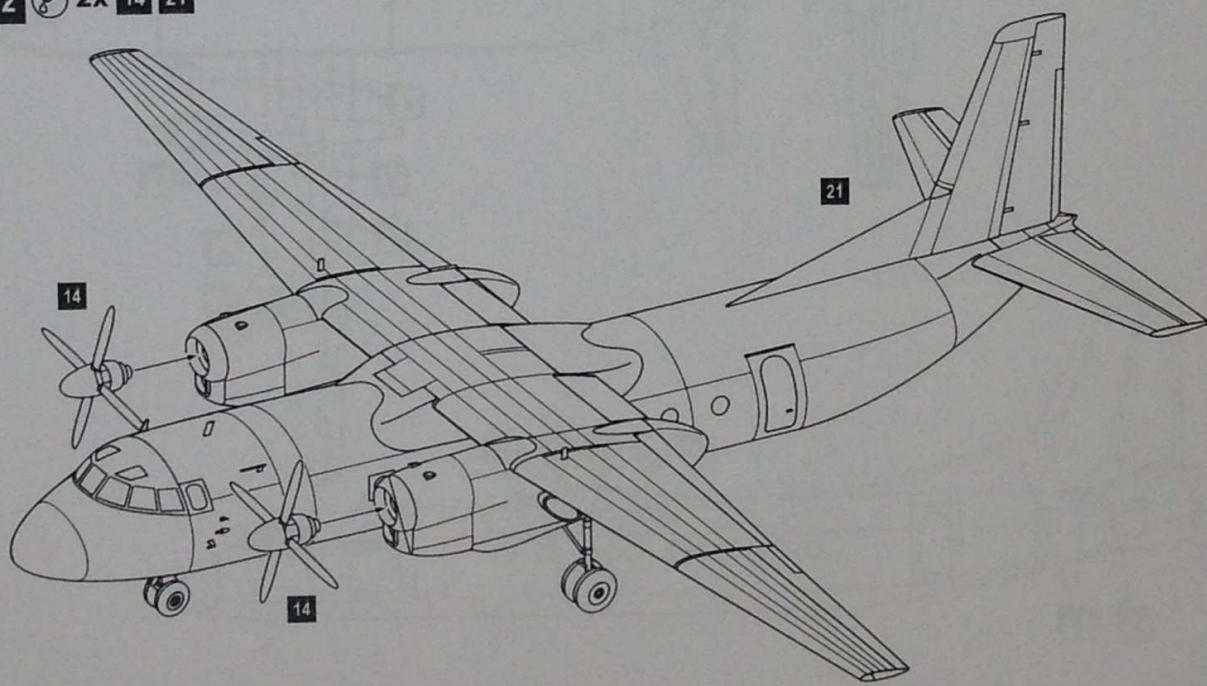



An-24, Aeroflot, USSR-46720 1962-65 years



- A** HUMBROL 147 LIGHT GREY СВЕТЛО СЕРЫЙ
- B** HUMBROL 27002 POL. ALUMINIUM ПОЛ. АЛЮМИНИЙ
- C** HUMBROL 27003 POLISHED STEEL ПОЛИР. СТАЛЬ
- D** HUMBROL 33 BLACK ЧЕРНЫЙ
- E** HUMBROL 24 YELLOW ЖЕЛТЫЙ
- F** HUMBROL 87 STEEL GREY СТАЛЬН. СЕРЫЙ
- G** HUMBROL 101 MID GREEN СРЕДНЕ ЗЕЛЕНЫЙ
- K** HUMBROL 27004 GUN METAL СТАЛЬНОЙ СЕРЫЙ
- L** HUMBROL 34 WHITE БЕЛЫЙ