

F/A-18E SUPER HORNET

The F/A-18E is the single-seat version of the Navy's new Super Hornet. Along with the two-seat F/A-18F, the multi-role fighter is now replacing the F-14 Tomcats and older F/A-18A and F/A-18C Hornets in the Navy's fighter and fighter/attack squadrons. Soon after Super Hornets were introduced into the squadron service, they began flying their first combat missions in Operation Enduring Freedom and Iraqi Freedom. Using precision-guided Joint Direct Attack Munitions (JDAM) and Laser Guided Bombs (LGB), Super Hornets attacked enemy targets with great accuracy. The Super Hornet is larger than the earlier "Legacy" Hornet versions,

and they have an additional pylon under each wing to carry more ordnance. They have more powerful engines for increased performance and have a greater range capability than the previous Hornet variants. Armed with the latest AIM-120 AMRAAM and AIM-9X Sidewinder missiles, the Super Hornet can effectively handle air-to-air missions as well as attacking targets on the ground. An internal 20-mm Vulcan cannon can be used in both the air-to-air and air-to-ground support roles. Super Hornets have also served as aerial tankers, making them an even more valuable and useful addition to the U.S. Navy's carrier air wings.



* REPEAT SEVERAL TIMES
* A REPETER PLUSIEURS FOIS



* OPTIONAL PARTS
* PIECES EN OPTION



* DECAL
* DECAL COMANIE



* ALTERNATIVE ASSEMBLY
* ENSEMBLAGE ALTERNATIVE



* CEMENT TOGETHER
* A COLLER



* REMOVE AND THROW AWAY
* A RETIRER ET JETER



* DO NOT CEMENT
* NE PAS COLLER

READ THIS BEFORE YOU BEGIN

- * Study the assembly drawings.
- * Each plastic part is identified by a number.
- * In the assembly drawings, some parts will be marked by a star (★) to indicate chrome plated plastic.
- * For better paint and decal adhesion, wash the plastic parts in a mild detergent solution. Rinse and let air dry.
- * Check the fit of each piece before cementing in place.
- * Use only cement for polystyrene plastic.
- * Scrape plating and paint from areas to be cemented.
- * Allow paint to dry thoroughly before handling parts.
- * Any unused parts may be discarded.

DECAL APPLICATION INSTRUCTIONS

1. Cut desired decal from sheet.
2. Dip decal in water for a few seconds.
3. Place wet decal on paper towel.
4. Wait until decal is movable on paper backing.
5. Place decal in position on model, face up and slide backing away.
6. Press out air bubbles with a soft damp cloth.
7. Milkiness that may appear is for better decal adhesion and will dry clear. Wipe away any excess adhesive.
8. Do not touch decal until fully dry.
9. Allow the decals 48 hours to dry before applying clear coat.

NOTE: Decals are compatible with setting solutions or solvents.

LIRE CE QUI SUIV AVANT DE COMMENCER

- * Etudier les schémas de montage.
- * Chaque pièce en plastique est identifiée par un numéro.
- * Sur les schémas de montage, certaines pièces sont marquées d'une étoile (★) pour indiquer qu'elles sont en plastique chromé.
- * Pour une meilleure prise de la peinture et des autocollants, laver les pièces en plastique avec une solution détergente peu concentrée. Les rincer et les laisser sécher à l'air.
- * Vérifier que chaque pièce s'ajuste bien avant de la coller en place.
- * N'utiliser que de la colle pour polystyrène.
- * Gratter les parties à coller pour enlever le chrome et la peinture.
- * Laisser la peinture bien sécher avant de manipuler les pièces.
- * Toute pièce inutilisée peut être jetée.

DIRECTIVES D'APPLICATION DES AUTOCOLLANTS

1. Découper l'autocollant désiré de la feuille.
2. Tremper l'autocollant dans de l'eau pendant quelques secondes.
3. Placer l'autocollant mouillé sur une serviette en papier.
4. Attendez que l'autocollant puisse être déplacé sur son support en papier.
5. Mettre l'autocollant en position sur le modèle face sur le dessus et faire glisser le support pour l'enlever.
6. Appuyer avec un chiffon doux humide pour éliminer les bulles d'air.
7. La substance laiteuse qui peut apparaître est destinée à améliorer l'adhésion de l'autocollant et devient incolore au séchage. Essuyer pour enlever tout excédent d'adhésif.
8. Ne pas toucher l'autocollant tant qu'il n'est pas bien sec.
9. Laisser l'autocollant sécher pendant 48 heures avant d'appliquer une couche transparente.

REMARQUE: Les autocollants sont compatibles avec les solutions de fixation ou les solvants.

This paint guide is provided to complete this kit as shown on the box.

Ce guide de peinture est fourni pour reproduire le modèle réduit qui apparaît sur la boîte.

Dark Ghost Gray	FS 36320	Gris fantôme foncé
Dark Gray	FS 35327	Gris foncé
Flat Black	FS 37038	Noir mat
Flat White	FS 37875	Blanc mat
Gloss Black	FS 17038	Noir brillant
Gloss White	FS 17875	Blanc brillant
Green		Vert
Insignia Red	FS 11136	Rouge emblème
Light Ghost Gray	FS 36375	Gris fantôme clair
Olive Drab	FS 34087	Gris vert
Red		Rouge
Silver		Argent
Steel		Acier
Flat Yellow		Jaune mat

If you have any questions or comments, call our hotline at: **(800) 833-3570**
or, please write to:

Revell Inc Consumer Service Department, 1850 Howard Street Unit A, Elk Grove Village, Illinois 60007

Be sure to include the plan number (85585010200), part number, description, your return address and phone number.

Visit our website: www.revell.com

1

COCKPIT / FUSELAGE ASSEMBLY

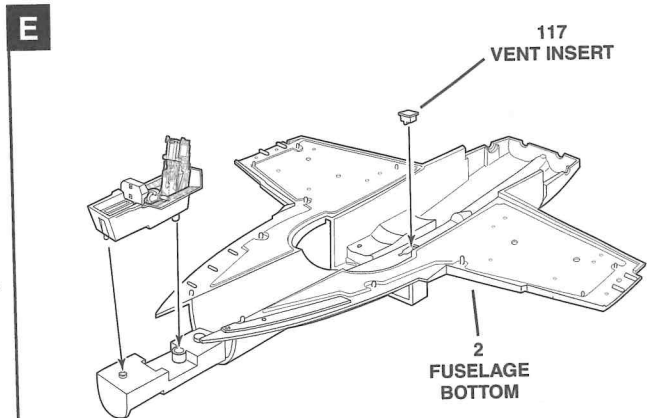
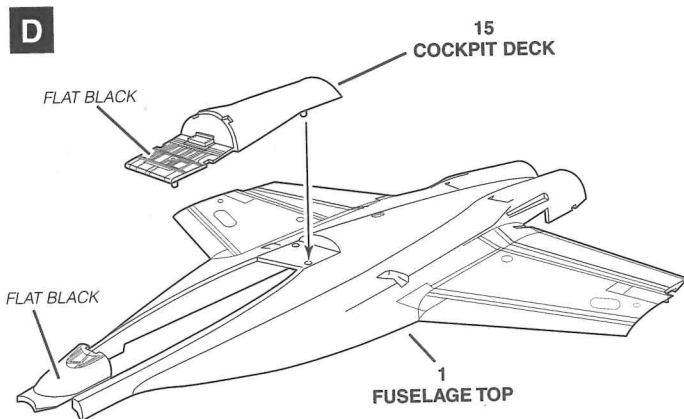
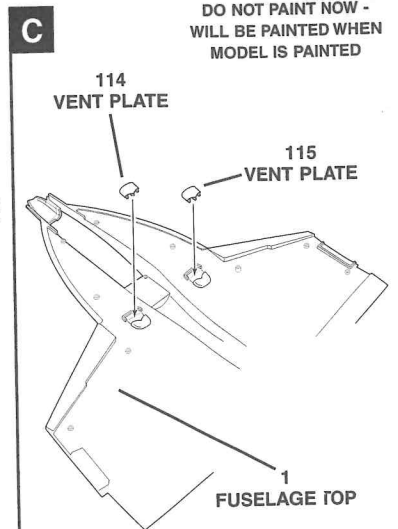
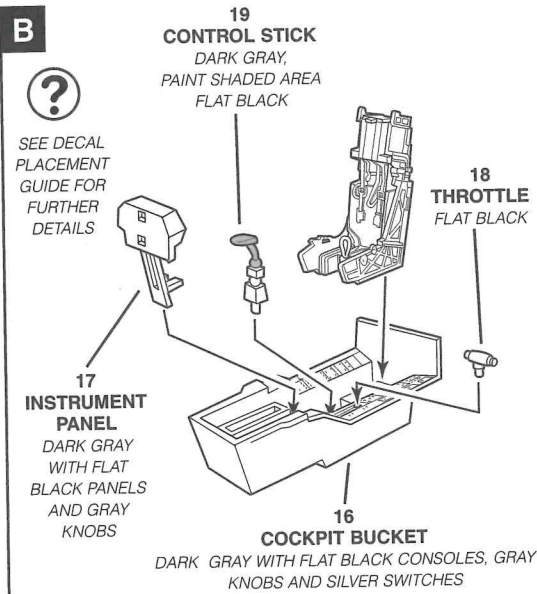
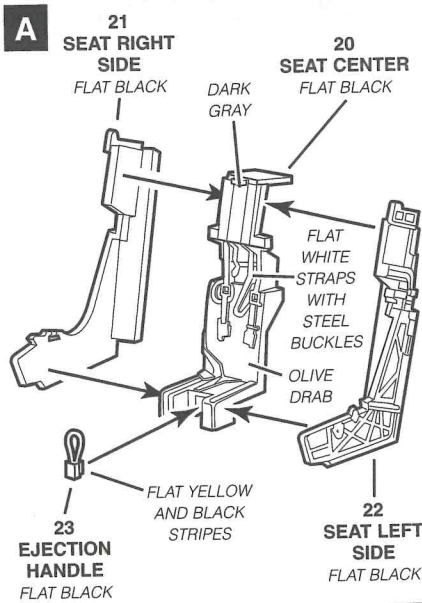

2

LEFT INTAKE ASSEMBLY

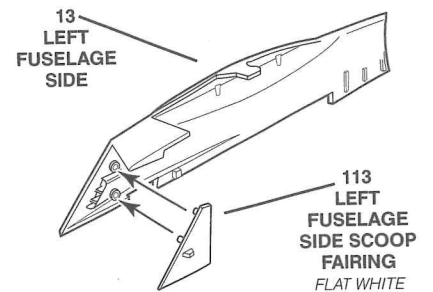
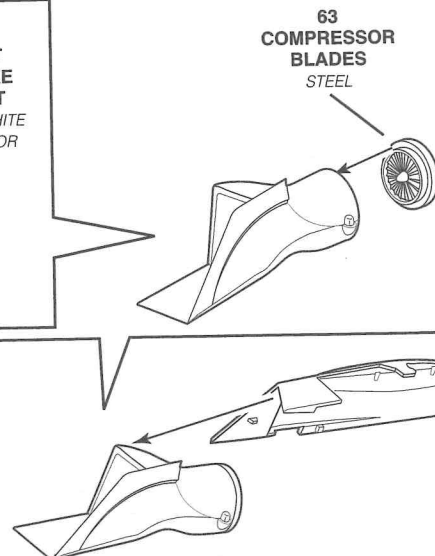
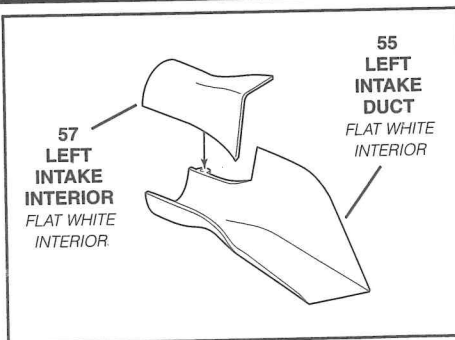

3

RIGHT INTAKE ASSEMBLY

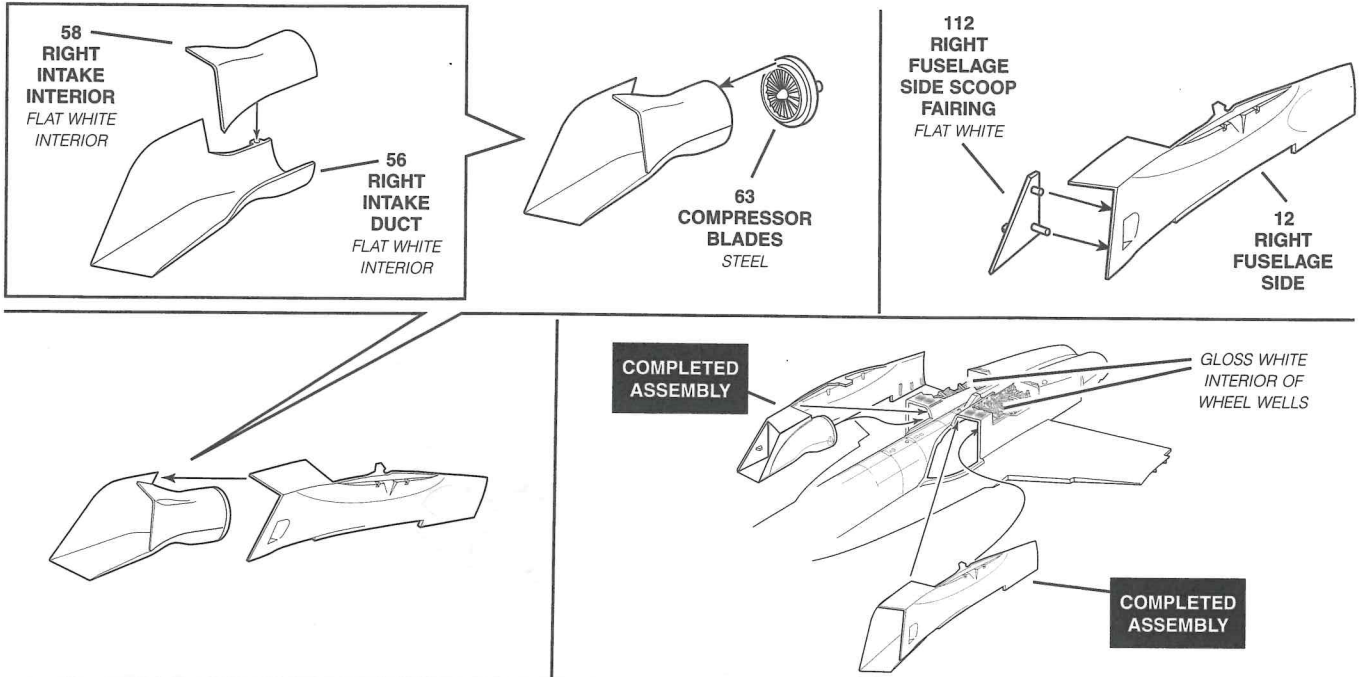

4

FUSELAGE AND NOSE ASSEMBLY

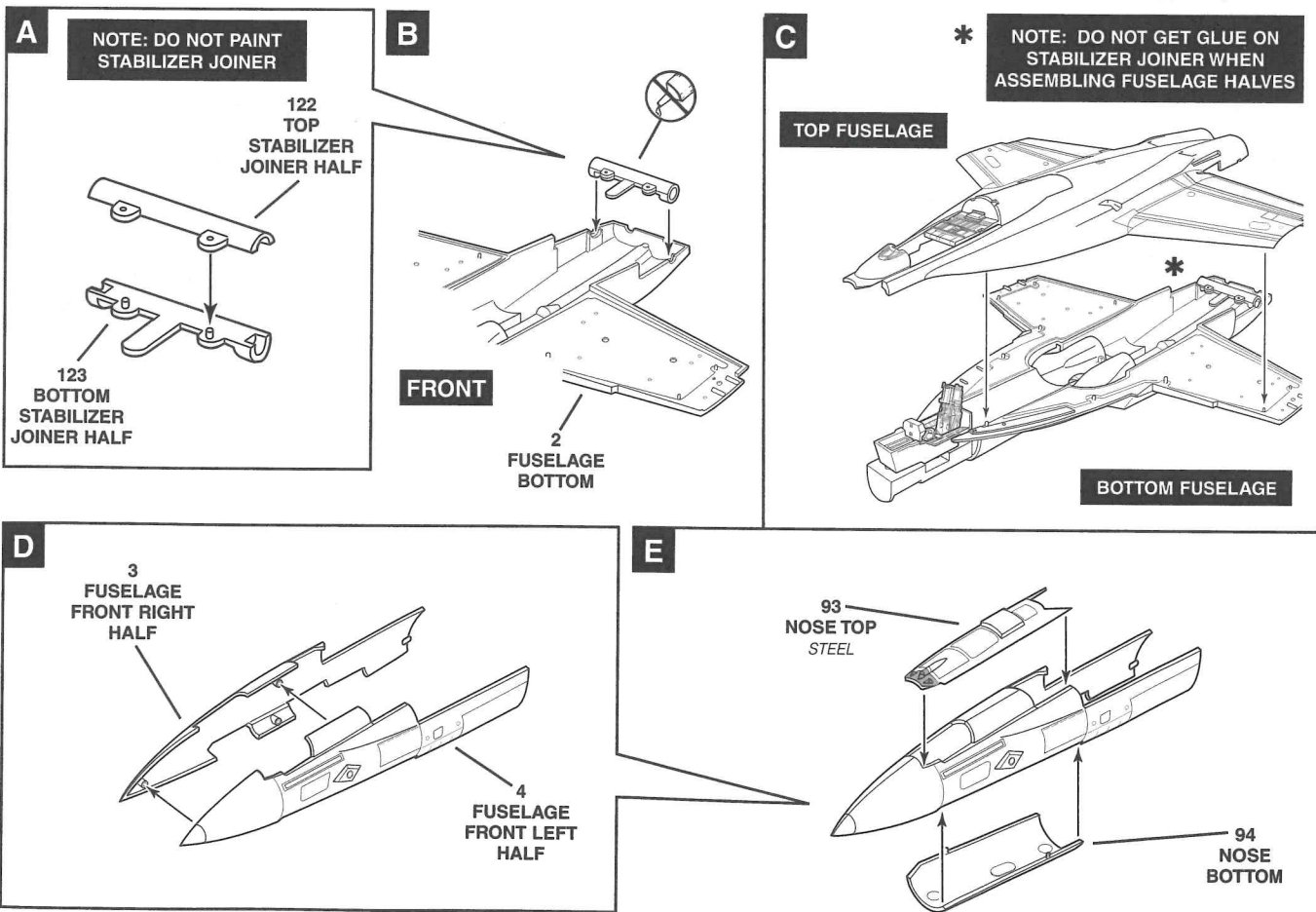

5

NOSE AND AFTERBURNERS ASSEMBLY

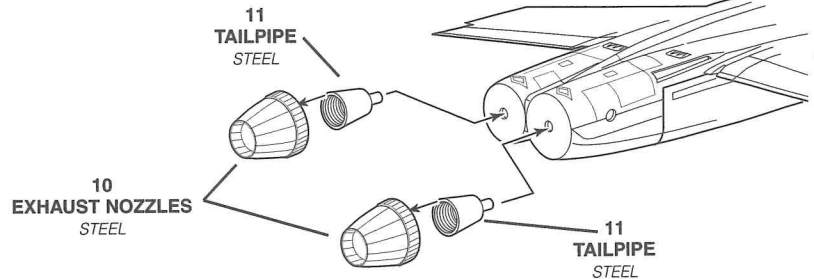
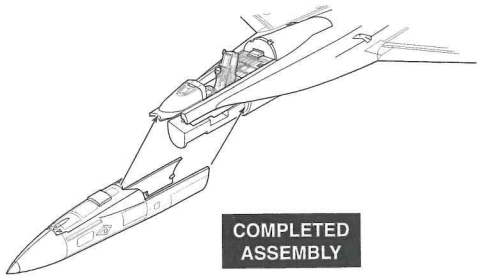

6

ASSEMBLY

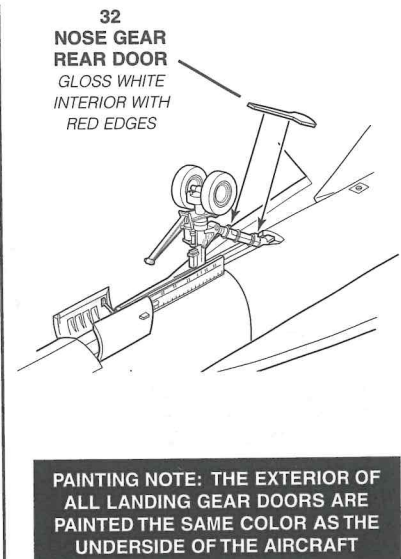
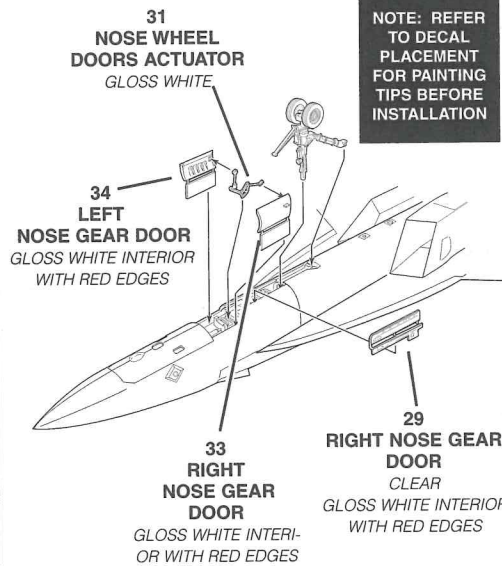
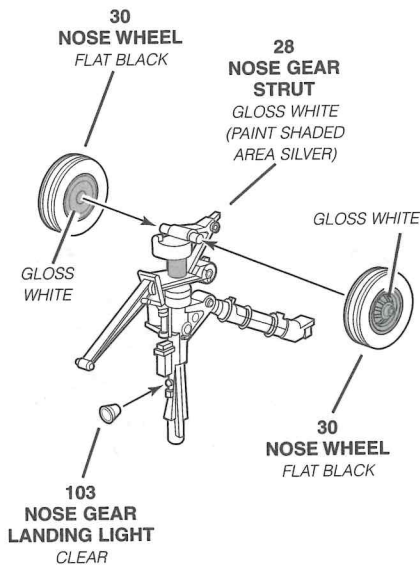

7

MAIN GEAR ASSEMBLY

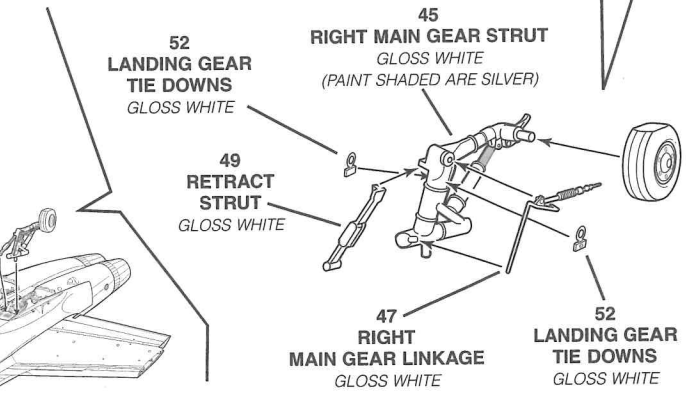
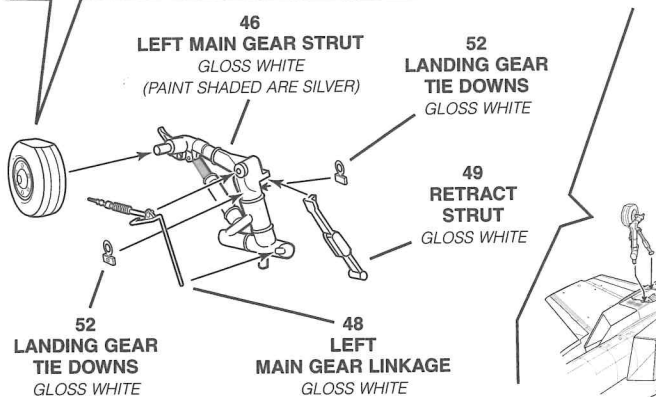
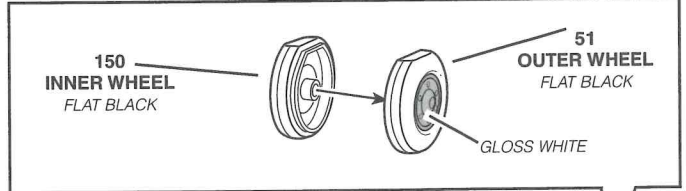
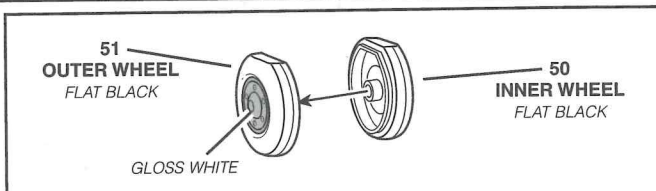

8

MAIN GEAR /HINGE ASSEMBLY

PAINTING NOTE: THE EXTERIOR OF ALL LANDING GEAR DOORS ARE PAINTED THE SAME COLOR AS THE UNDERSIDE OF THE FUSELAGE, THE INTERIOR OF THE DOORS ARE PAINTED GLOSS WHITE, AND THE INDENTED EDGES OF THE INTERIOR OF EACH DOOR IS PAINTED RED

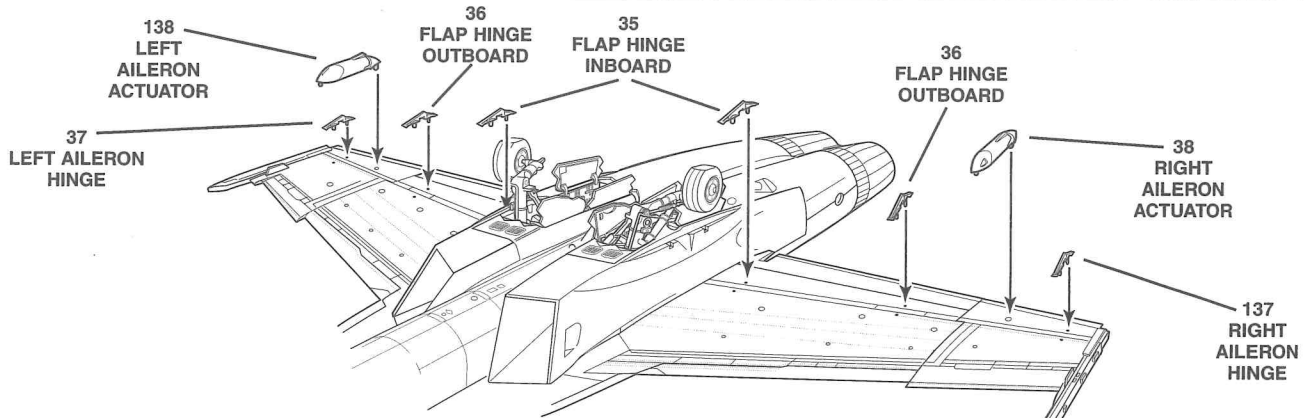
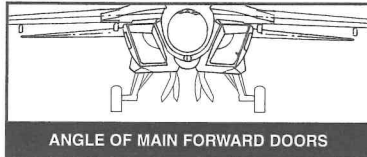
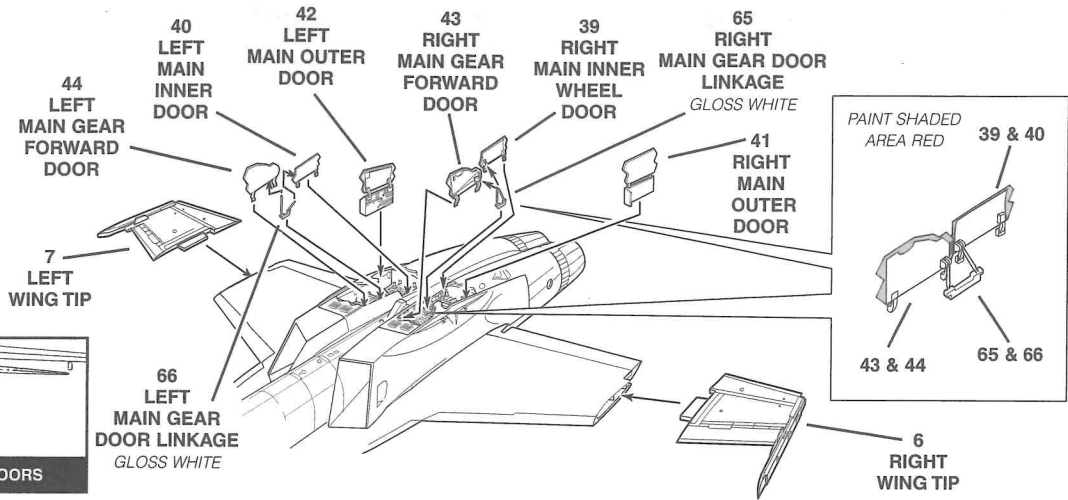

9

PYLON ASSEMBLY

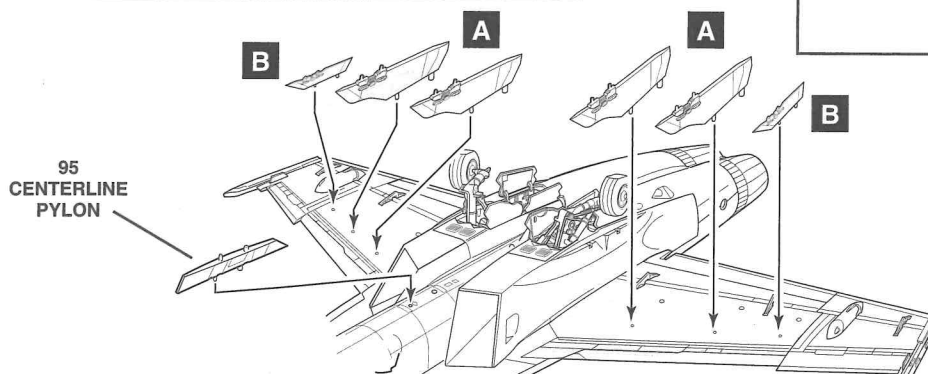
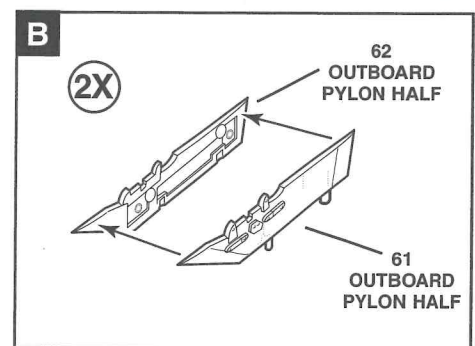
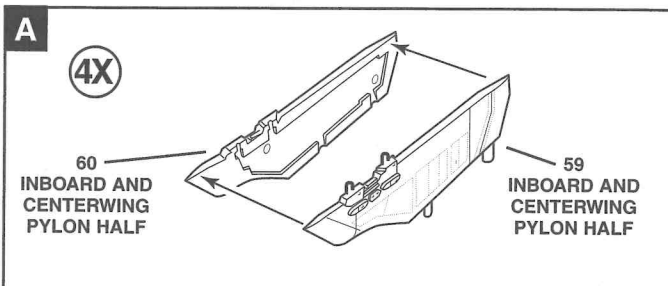

PAINTING NOTE: SEE THE PAINTING GUIDE AT THE BACK OF THE INSTRUCTION BOOKLET FOR INFORMATION ON HOW TO PAINT THE BOMBS AND MISSILES AND WHERE TO APPLY DECALS

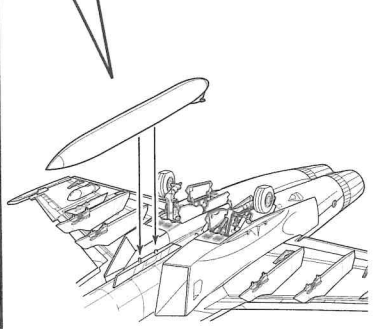
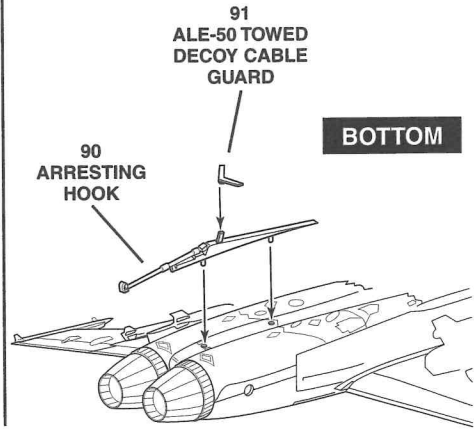
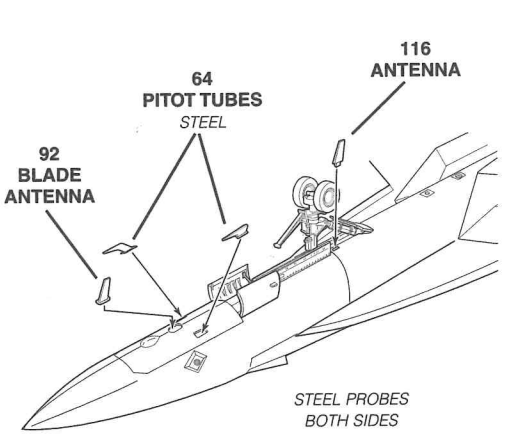
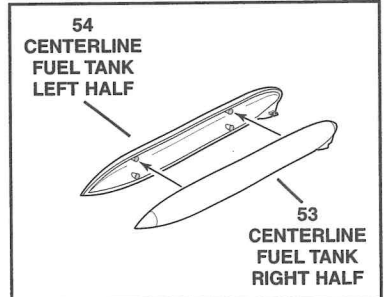
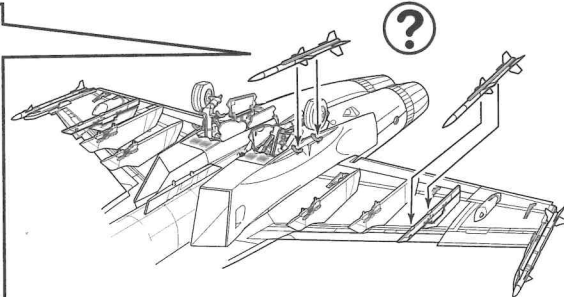
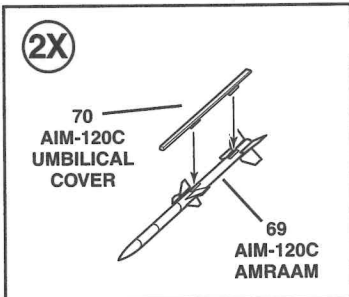
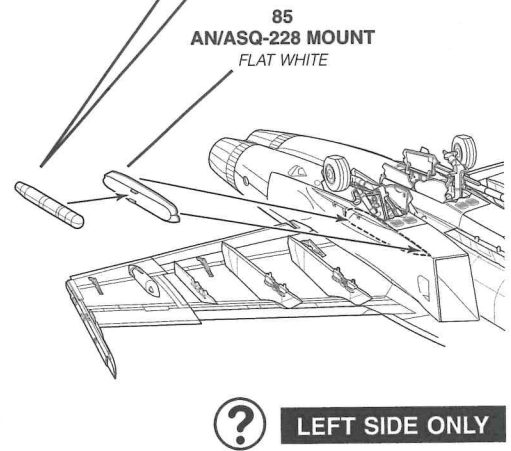
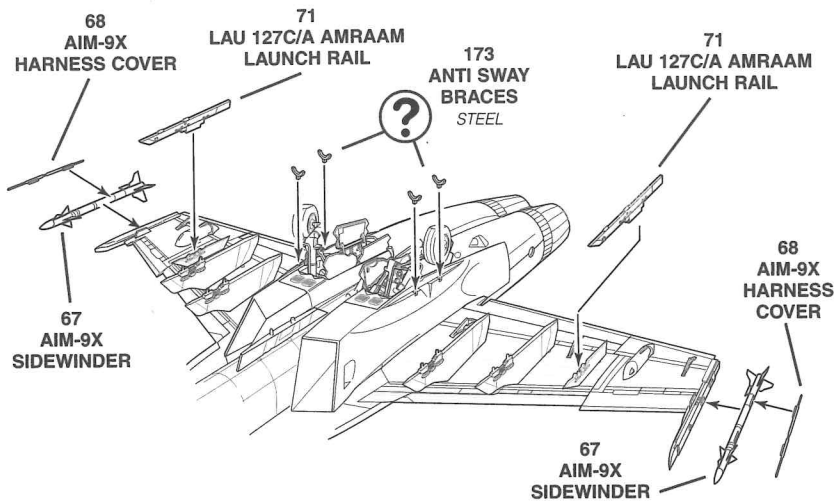
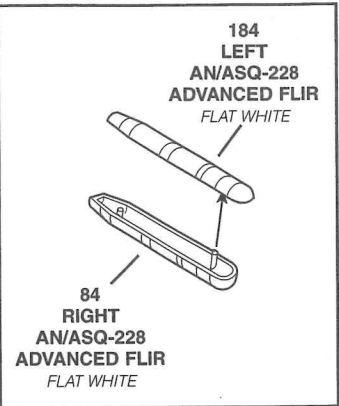
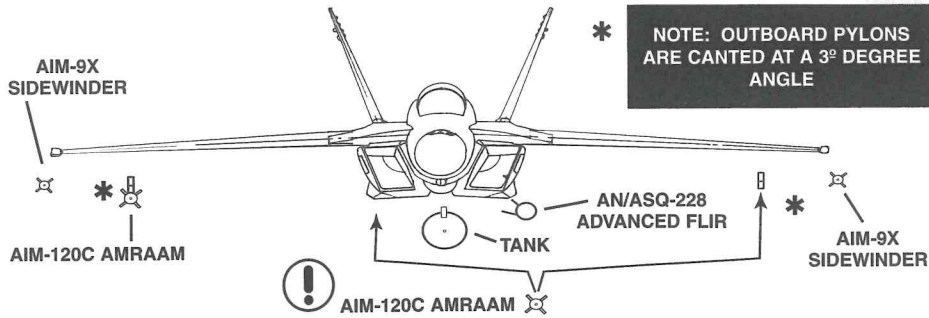

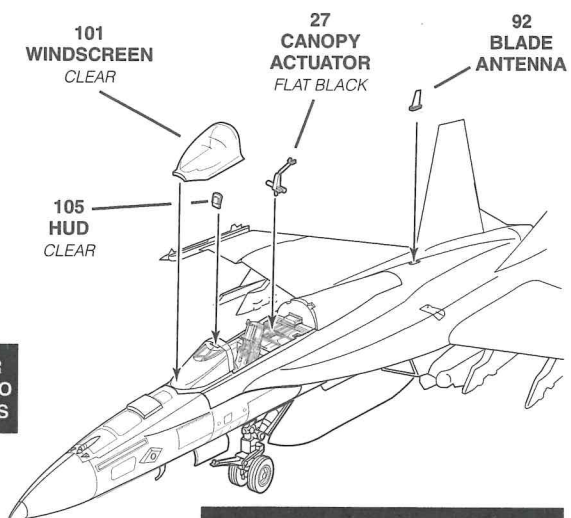
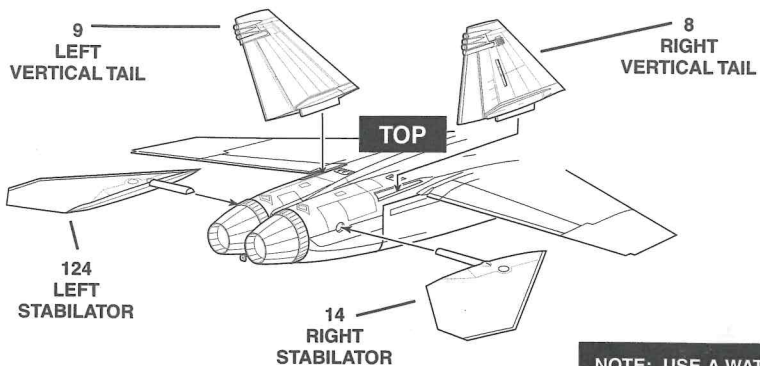

NOTE: USE A WATER BASED WHITE GLUE TO ATTACH CLEAR PARTS

PAINTING NOTE: PAINT WINDSCREEN FRAME THE SAME COLOR AS THE SURROUNDING FUSELAGE

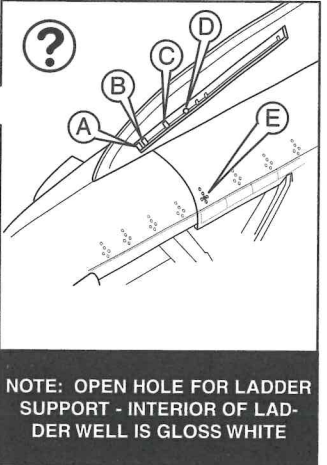
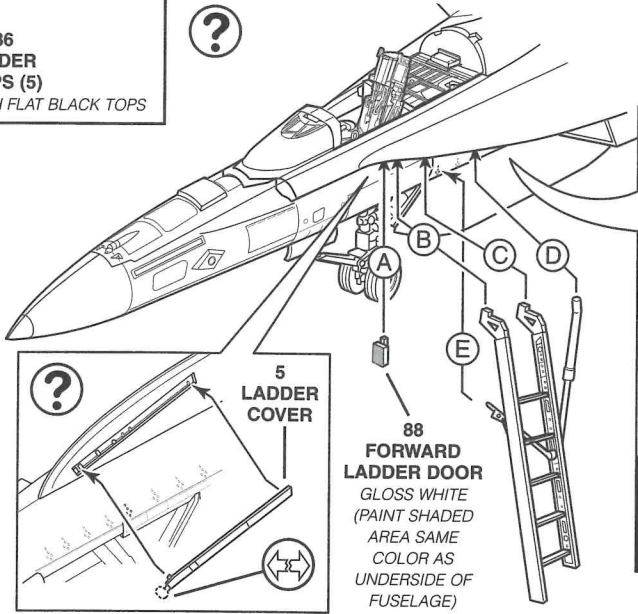
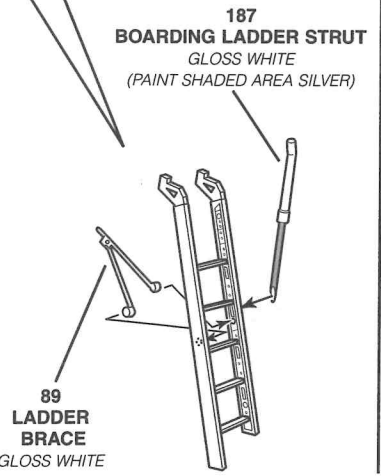
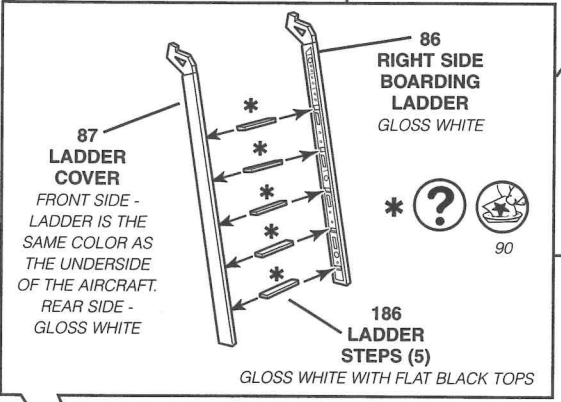
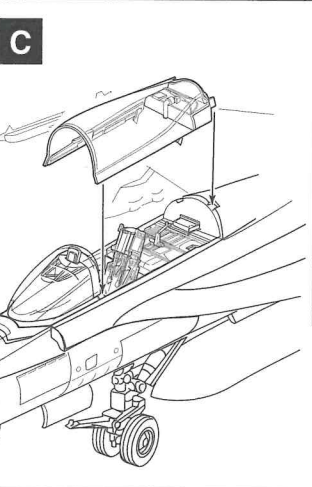
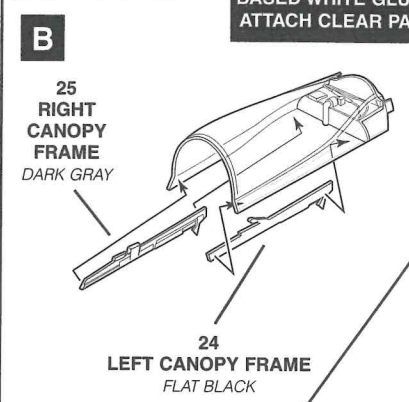
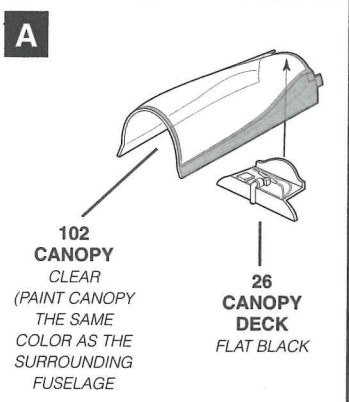

NOTE: OPEN HOLE FOR LADDER SUPPORT - INTERIOR OF LADDER WELL IS GLOSS WHITE

**F/A-18E SUPER HORNET. BUNO 165538, VFA-122 FLYING EAGLES,
NAS LEMOORE, CALIFORNIA,
JUNE, 2005.**

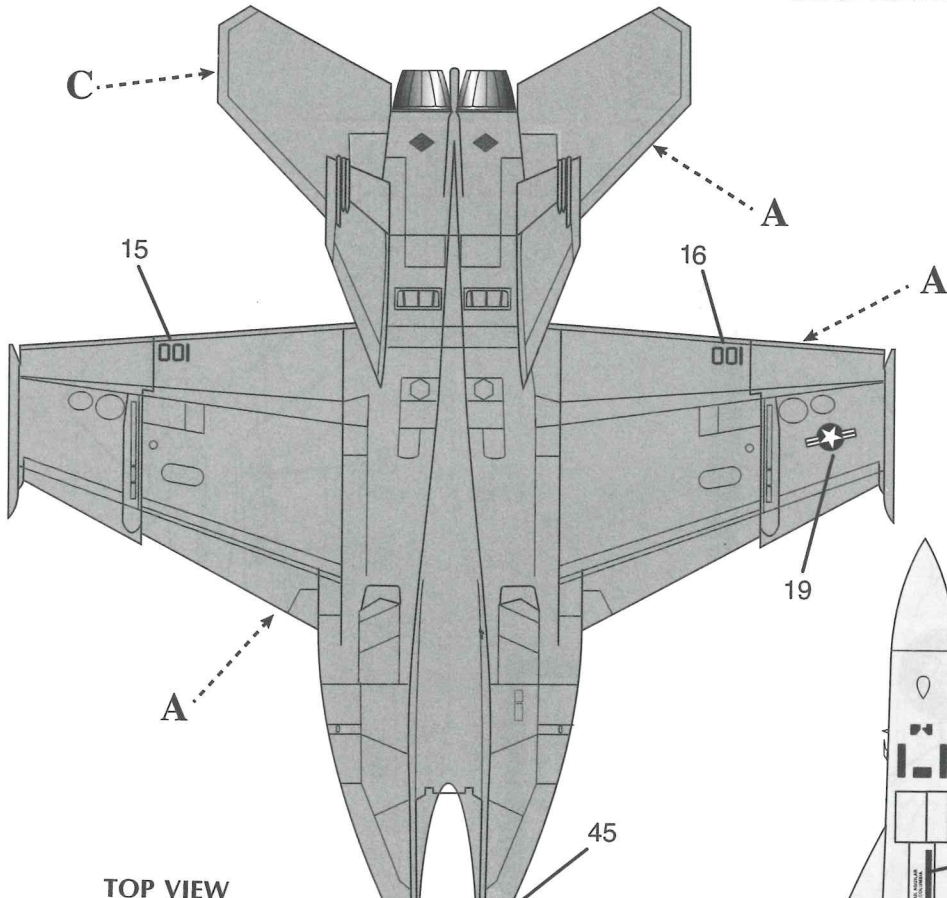

TOP VIEW

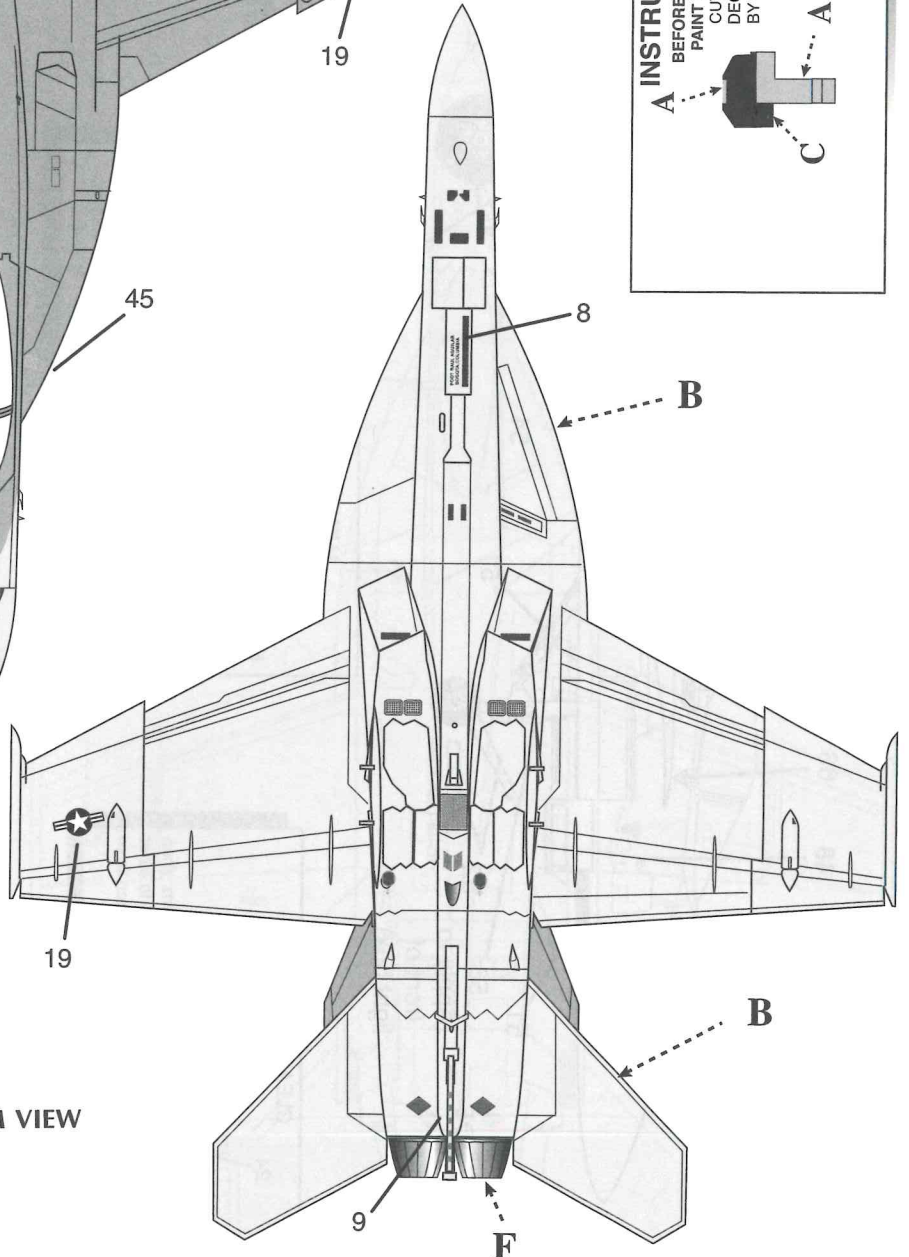
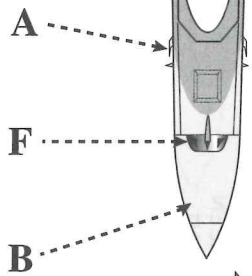

BOTTOM VIEW

INSTRUMENT PANEL DETAILS

BEFORE APPLYING DECALS
PAINT PANEL AS SHOWN
CUT INSTRUMENT
DECAL AS SHOWN
BY DOTTED LINES

Panel 1A= power off
Panel 1B= power on

EJECTION SEAT DECAL

STENCIL PLACEMENT

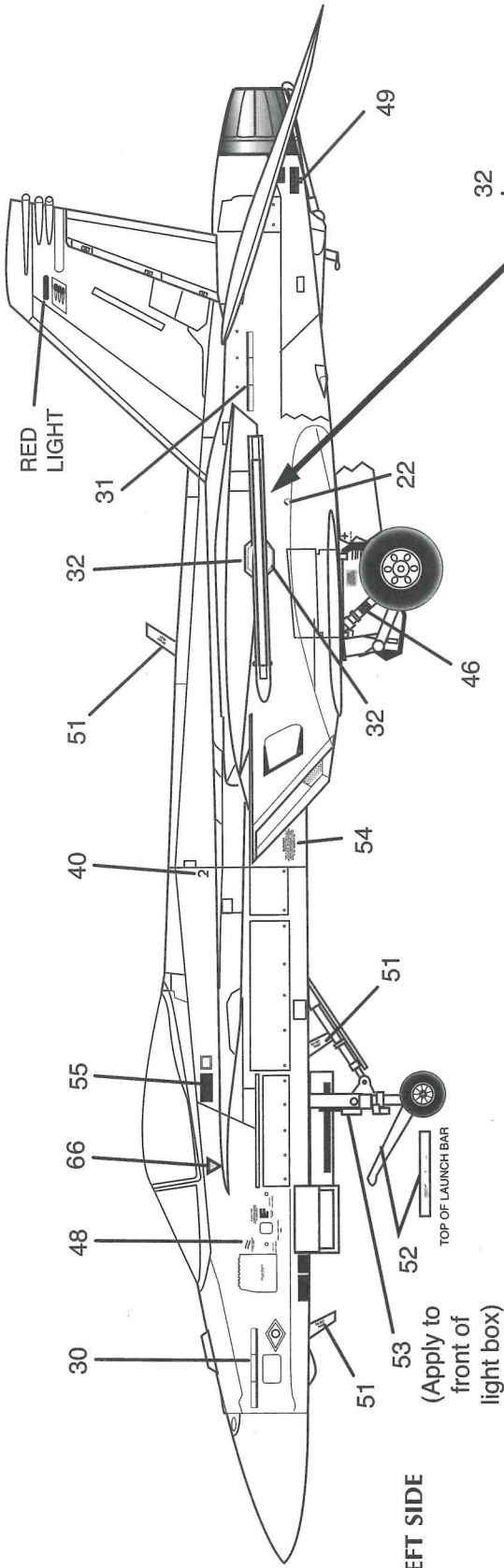

LEFT SIDE
(Apply to front of light box)

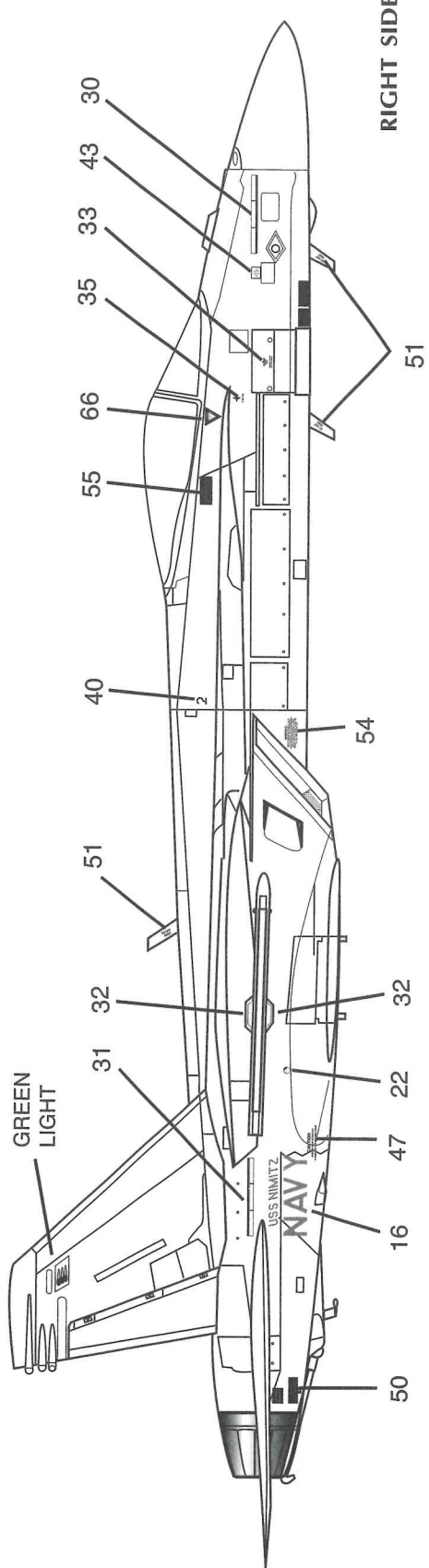
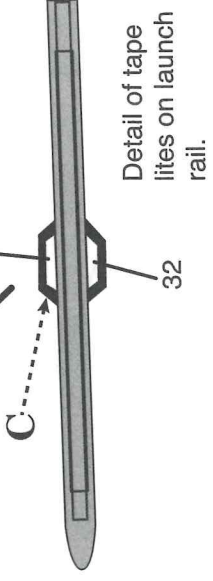
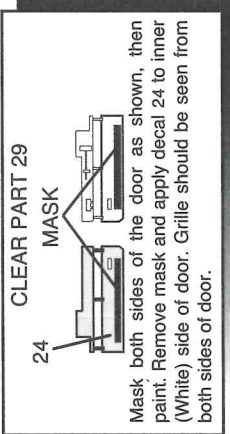
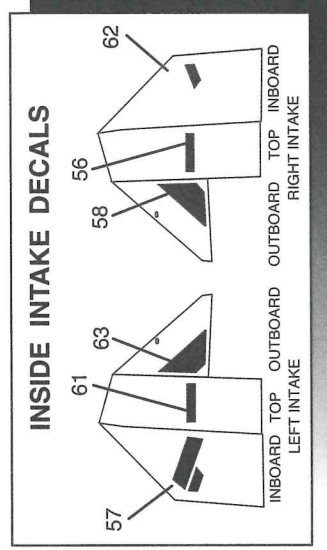

RIGHT SIDE

STENCIL PLACEMENT

TYPICAL DECAL PLACEMENT ON INSIDE OF DOORS

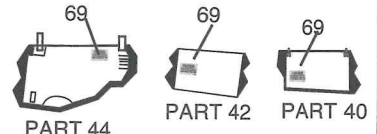

The inside of all landing gear doors are white with red edges.

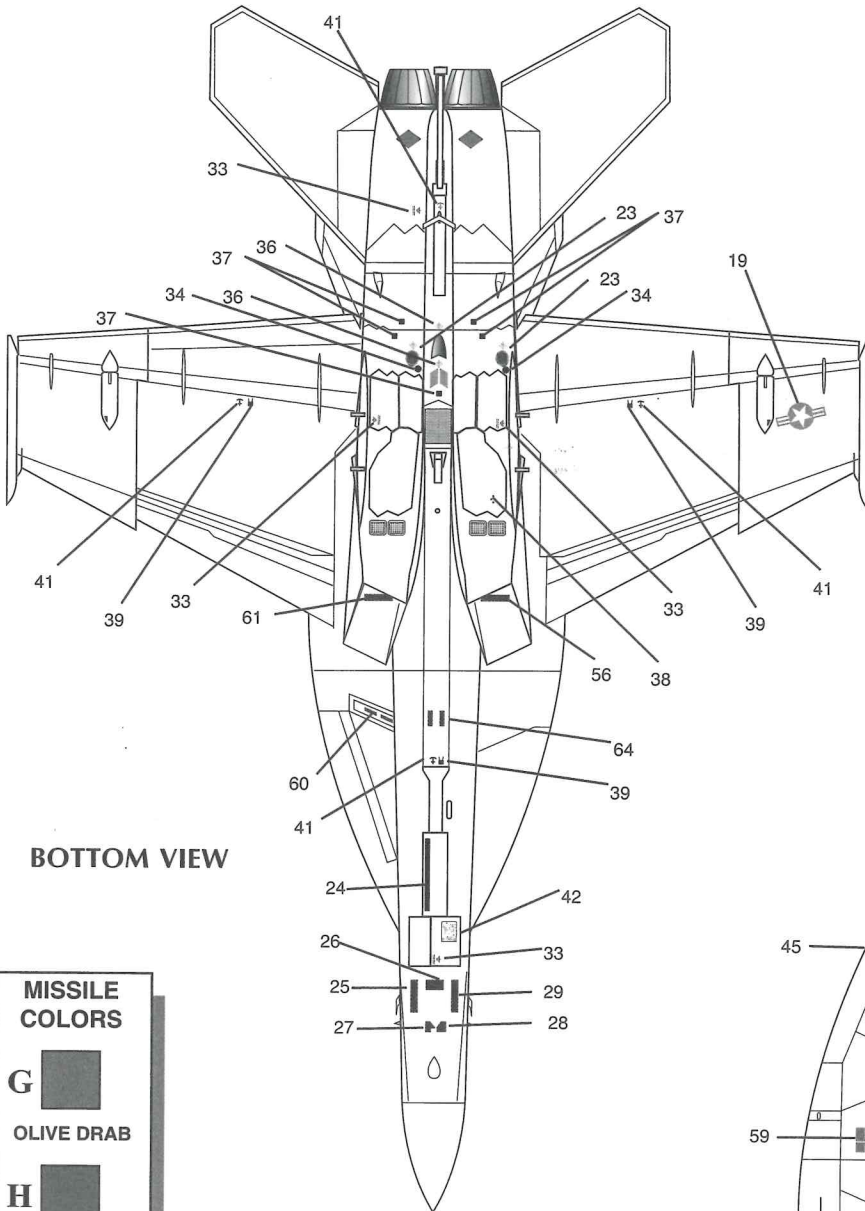

BOTTOM VIEW

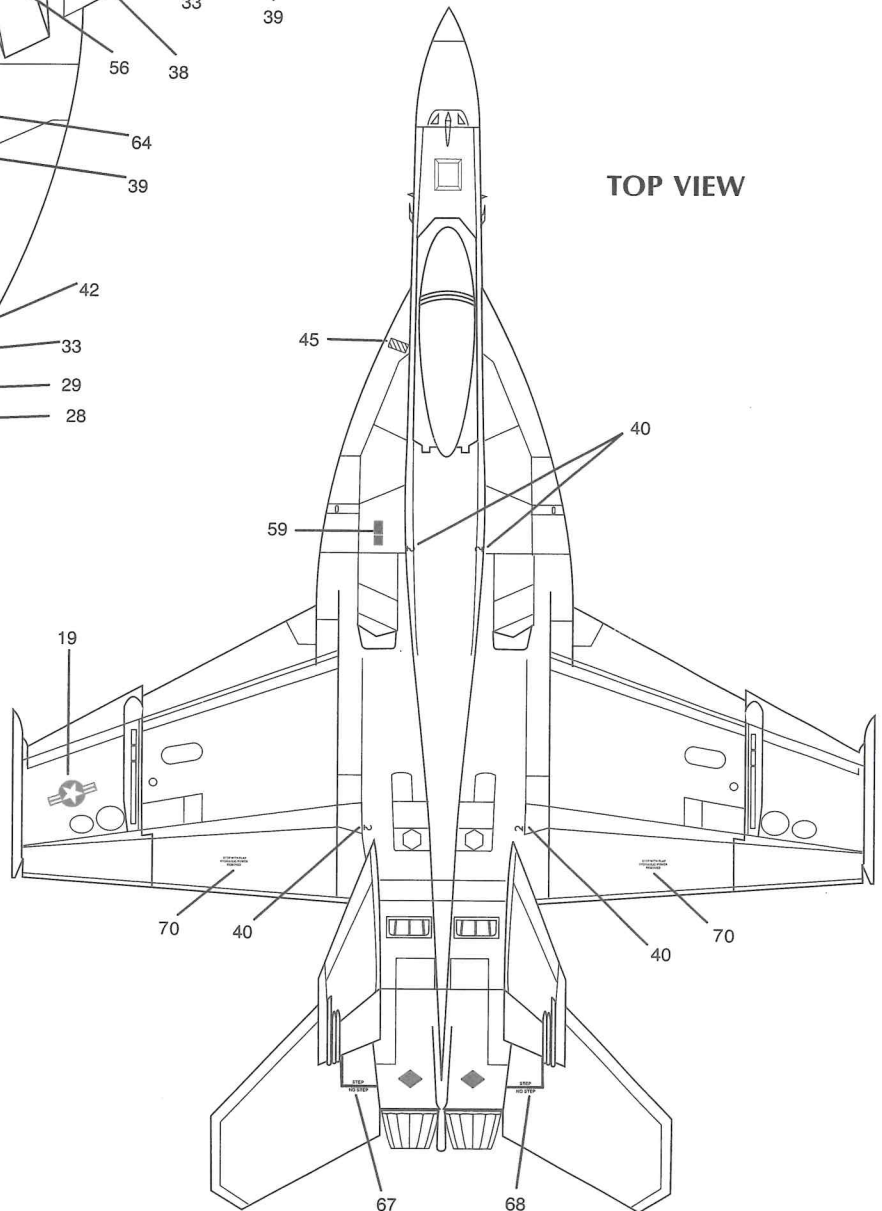

TOP VIEW

MISSILE COLORS

- G** ■ OLIVE DRAB
- H** ■ PURPLE PEARL TESTOR 4643

