



# CONSOLIDATED B-24D LIBERATOR

**ACADEMY**  
**MINICRAFT**  
MODEL KITS

In 1938, the USAAF asked the Consolidated Aircraft Co. (later known as Convair) to design a heavy bomber with performance exceeding the new B-17 Flying Fortress. Consolidated had been experimenting with a narrow, high-lift wing and it was already flying on a proposed civil flying boat project, known as the Model 31. The new bomber was designed around the wing and tail arrangement of the Model 31. Designated XB-24, the new bomber looked so promising on paper that the Air Corps ordered seven YB-24's and another 31 planes were on the books before the XB-24 had even flown. Eventually, the B-24 was named Liberator and went on to become the most widely produced American bomber in World War II.

Consolidated's B-24 was clumsy-looking alongside the slim B-17 Fortress, and it became common for the B-17 crews to refer to B-24 as "the crate the B-17 was shipped in", but the ponderous shape of the Liberator was the secret of its great bomb load. It was also slightly faster and had a greater range than the B-17.

The first production version of the Liberator was the B-24D, which was distinguished by a greenhouse-type nose instead of the power turret mounted on later versions. One of the reasons for the large quantity of B-24's to roll from the assembly lines lay in the fact that they were being built by Douglas, Ford and North American.

B-24D's were used on nearly every operational front during the War. The Goon, depicted by this Minicraft model, was operated by the 308th Bombardment Group of the Fourteenth Air Force, flying in the CBI (China, Burma, India) theatre.

# 1 GUN ASSEMBLY

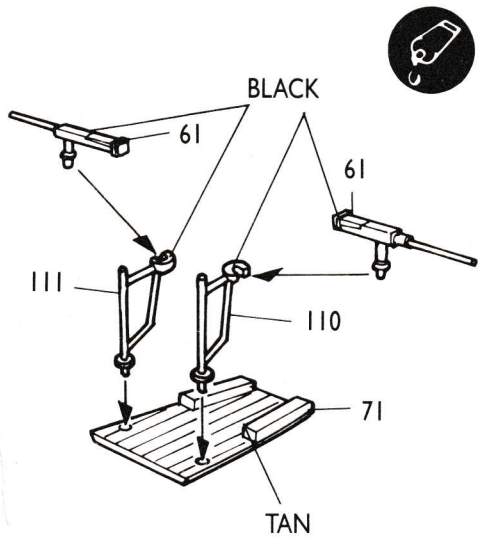

# 2 COCKPIT

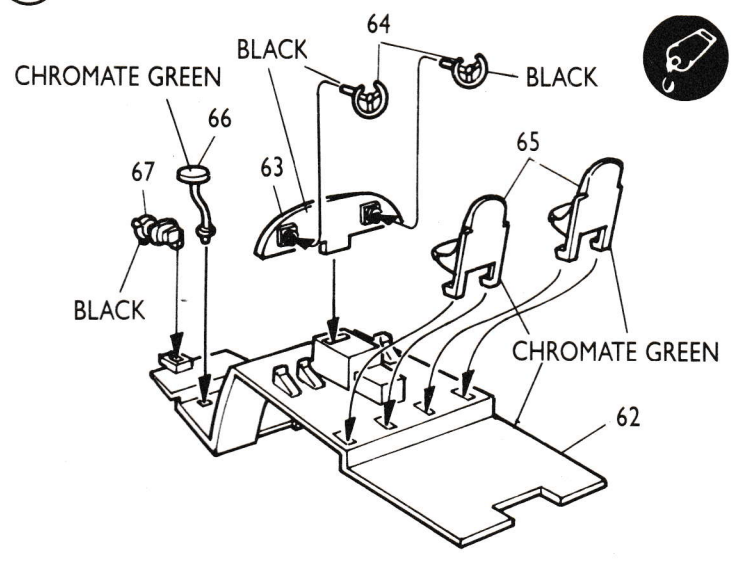

# 3 FUSELAGE INTERIOR

(Repeat for Left side)

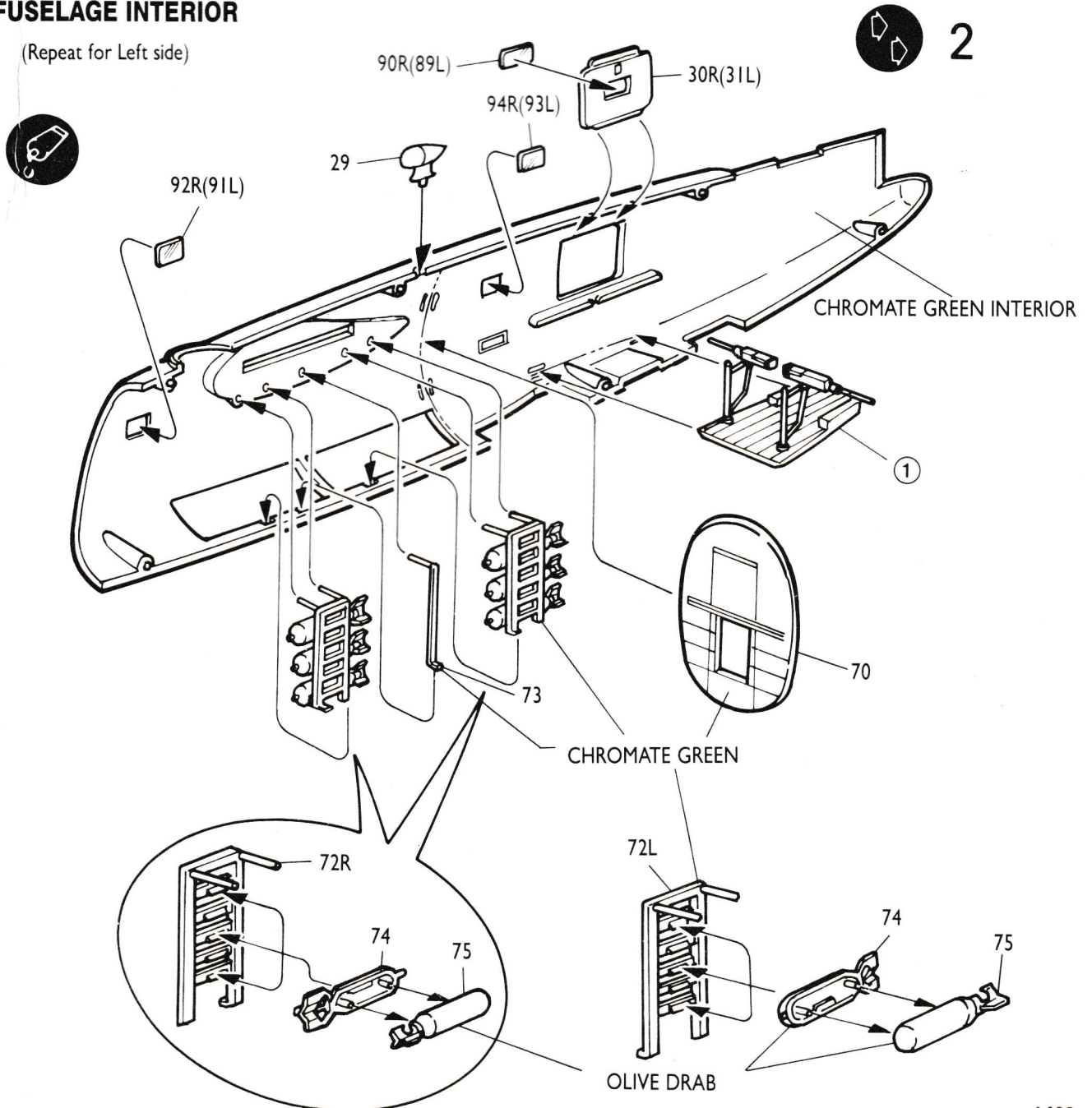

### 4 NOSE WHEEL

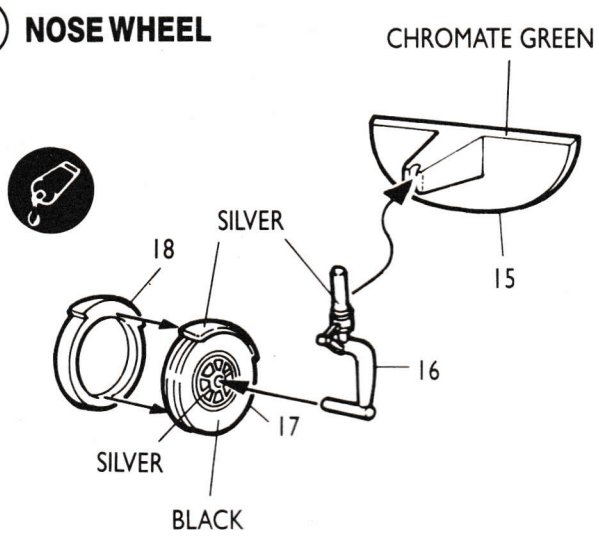

### 5 TAIL TURRET

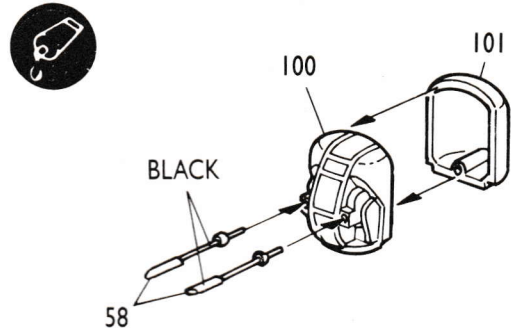

### 6 COCKPIT INSTALLATION

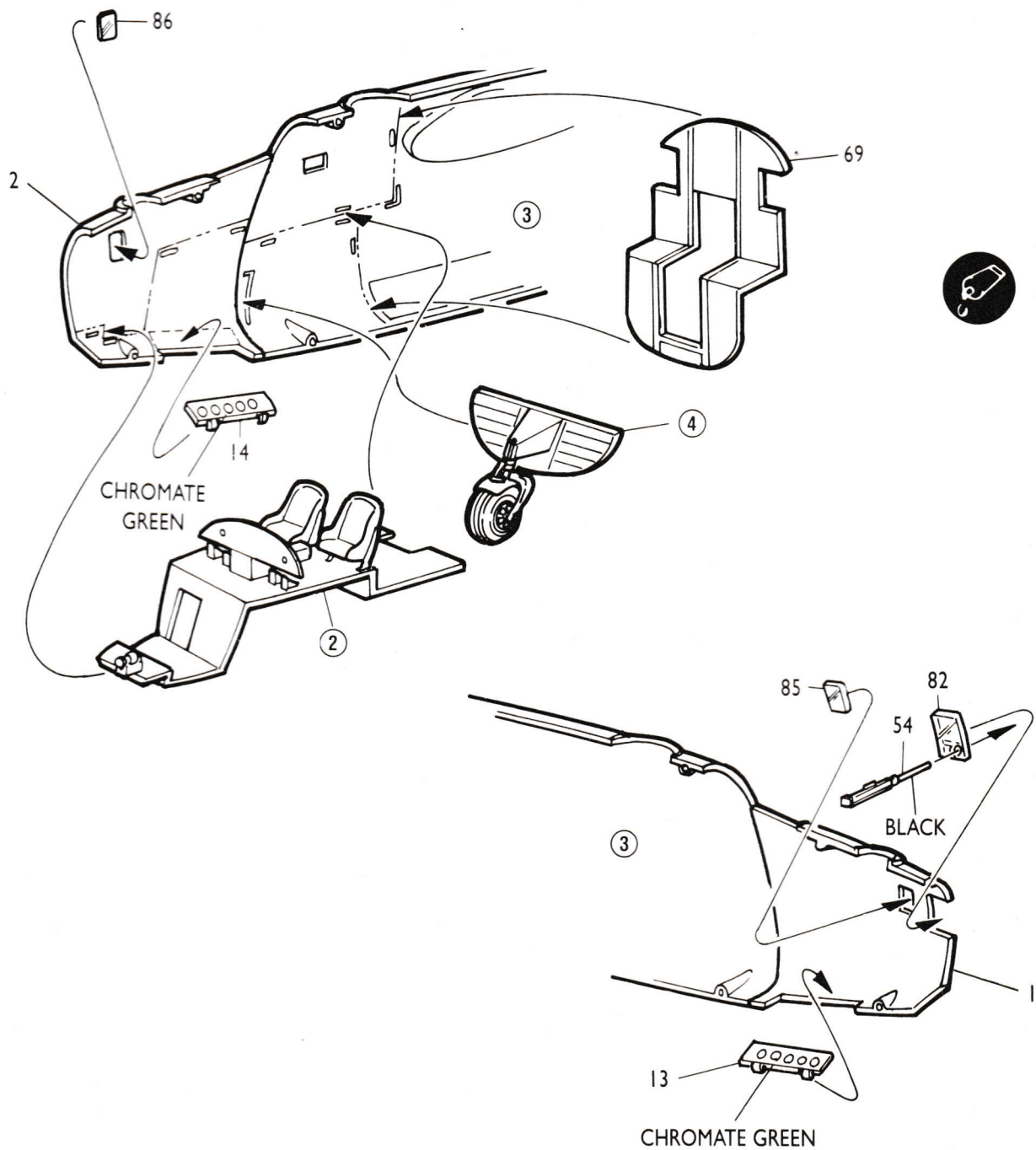

# 7 MAIN FUSELAGE ASSEMBLY

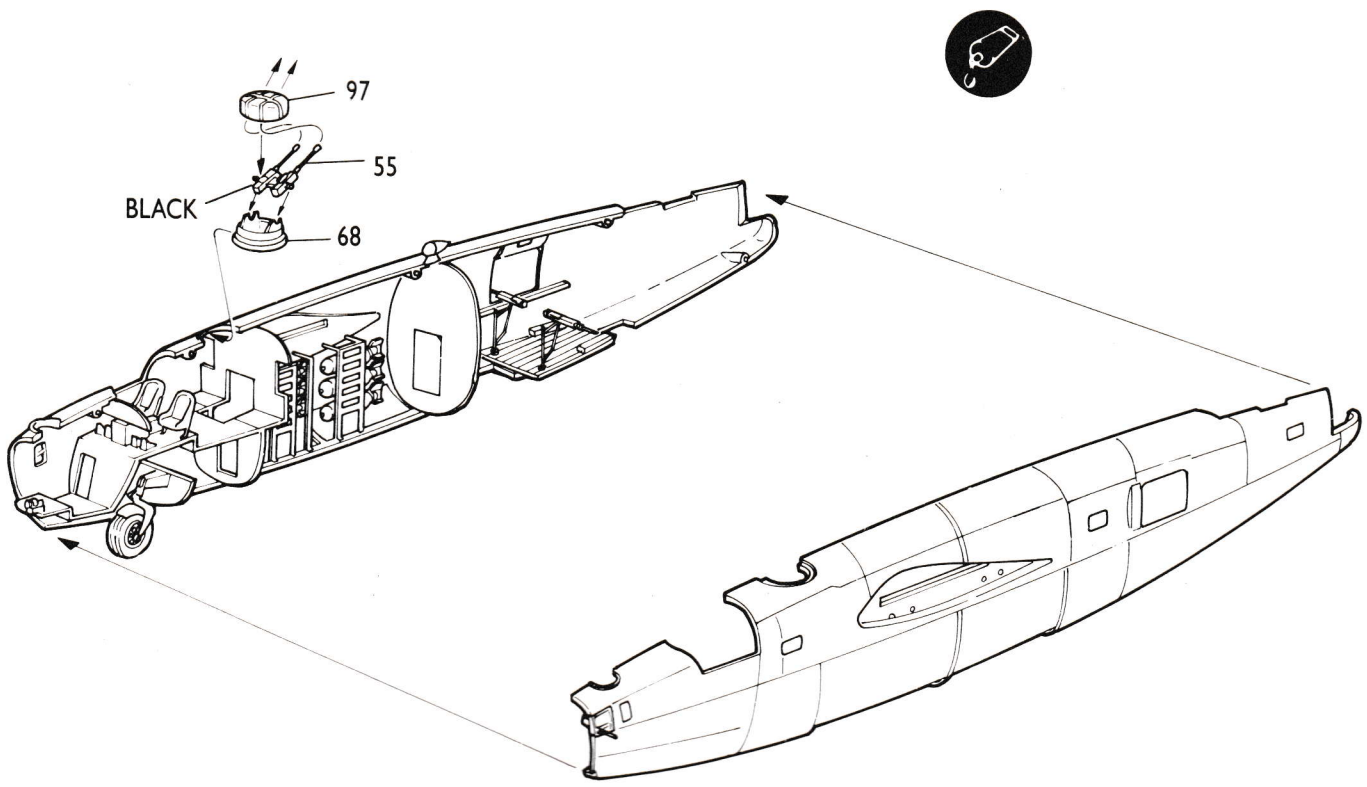

# 8 FORWARD FUSELAGE ASSEMBLY

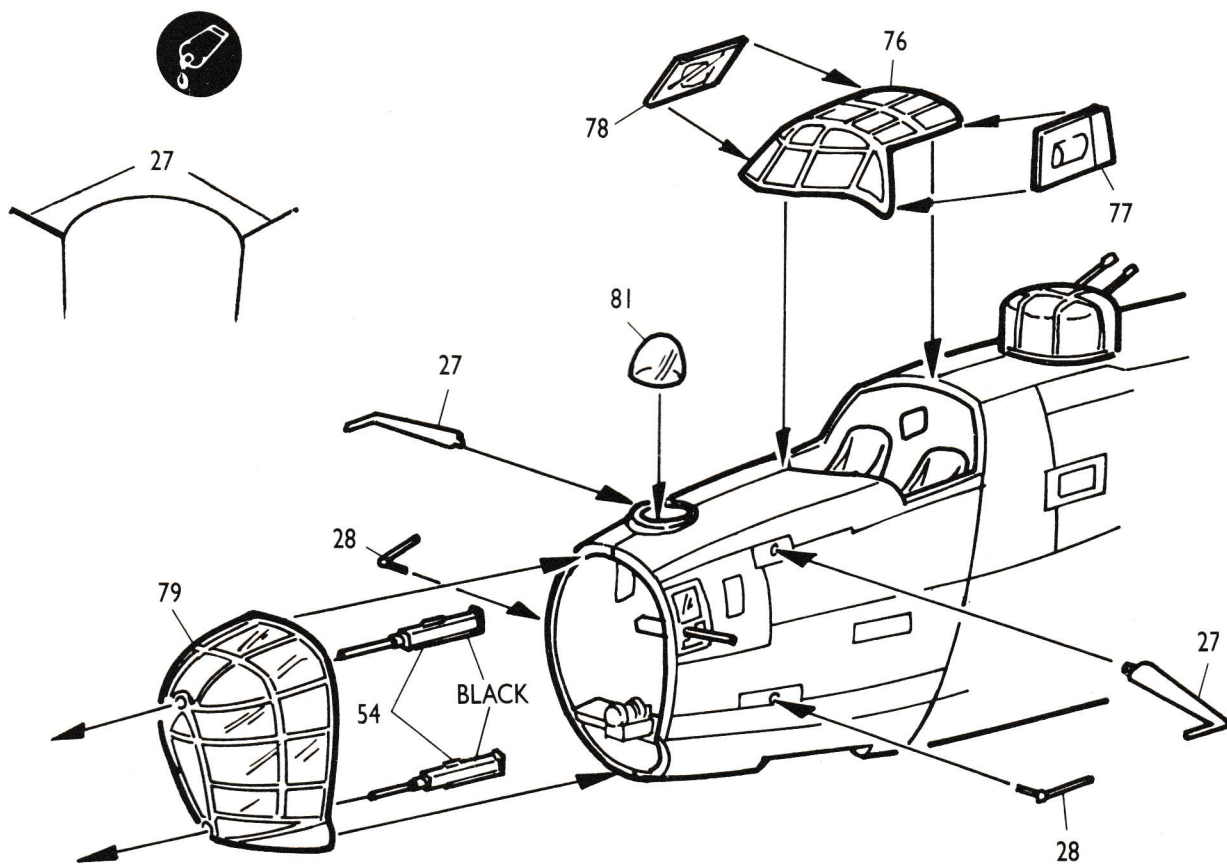

**9 BOMB BAY DOORS (CLOSED)**

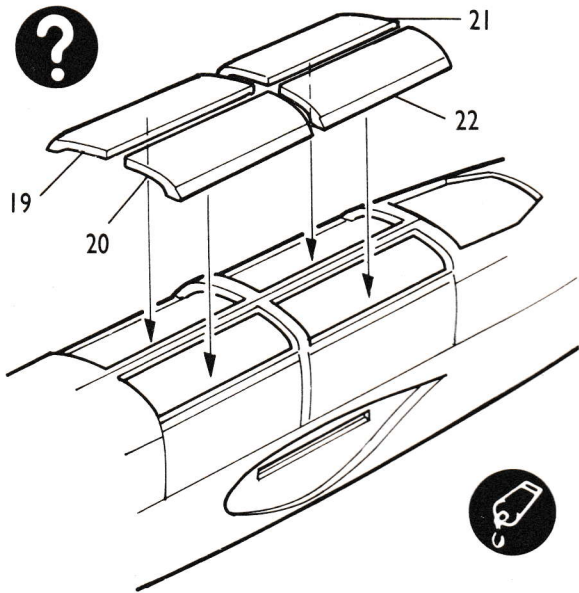

**10 BOMB BAY DOORS (OPEN)**

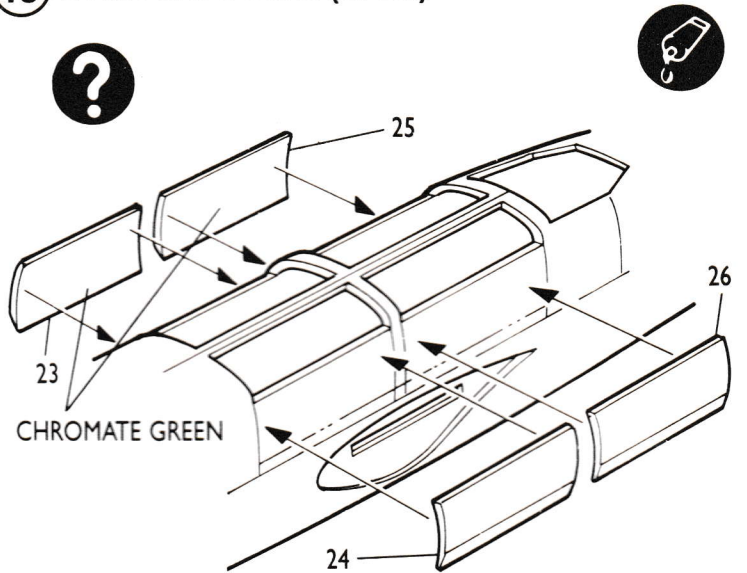

**11 LOWER PANEL**

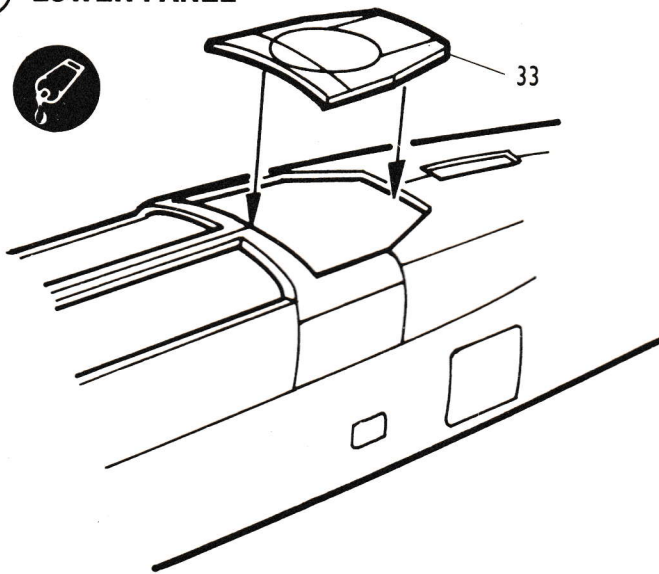

**12 LOWER REAR FUSELAGE**

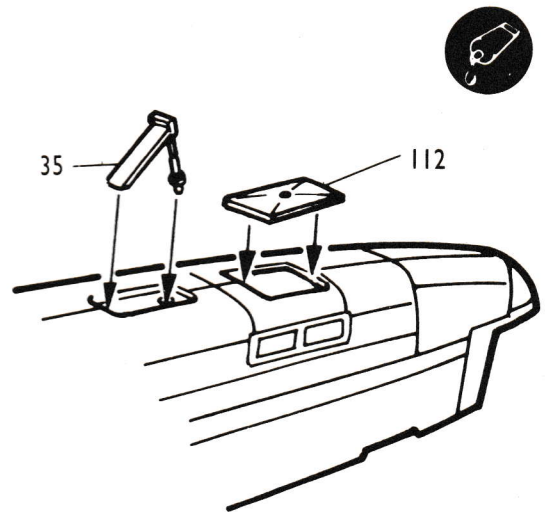

**13 REAR TURRET INSTALLATION**

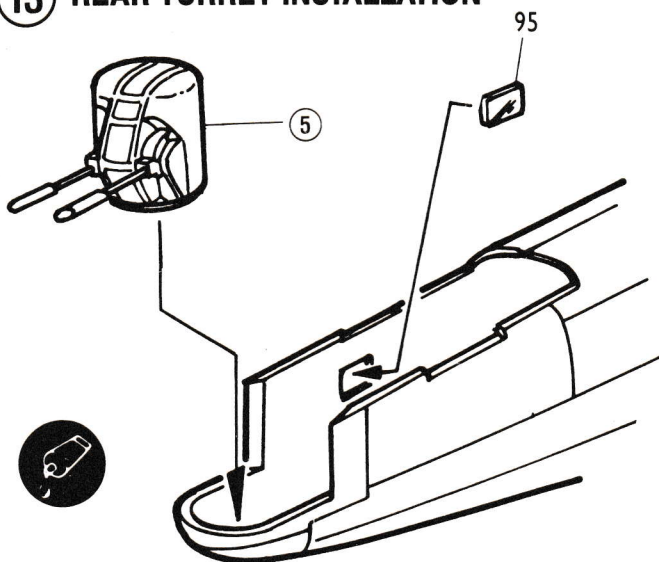

**14 ENGINE ASSEMBLY**

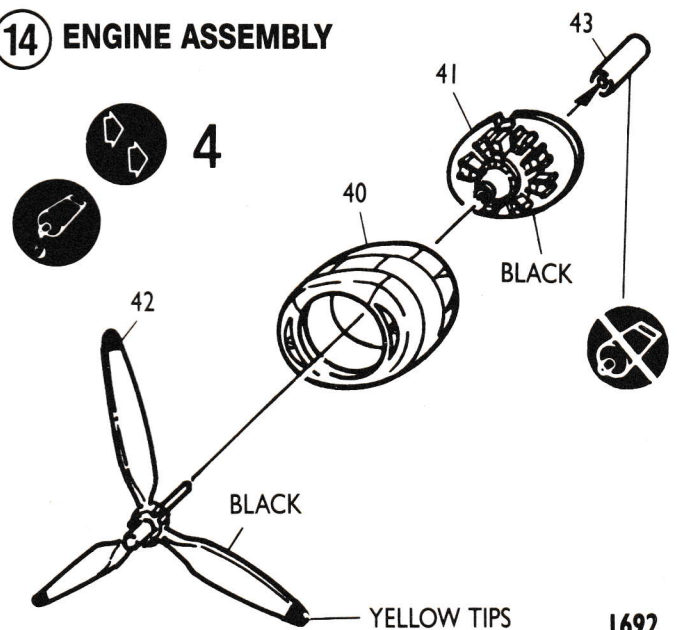

# 15 WING ASSEMBLY

2 (Repeat for Left side)

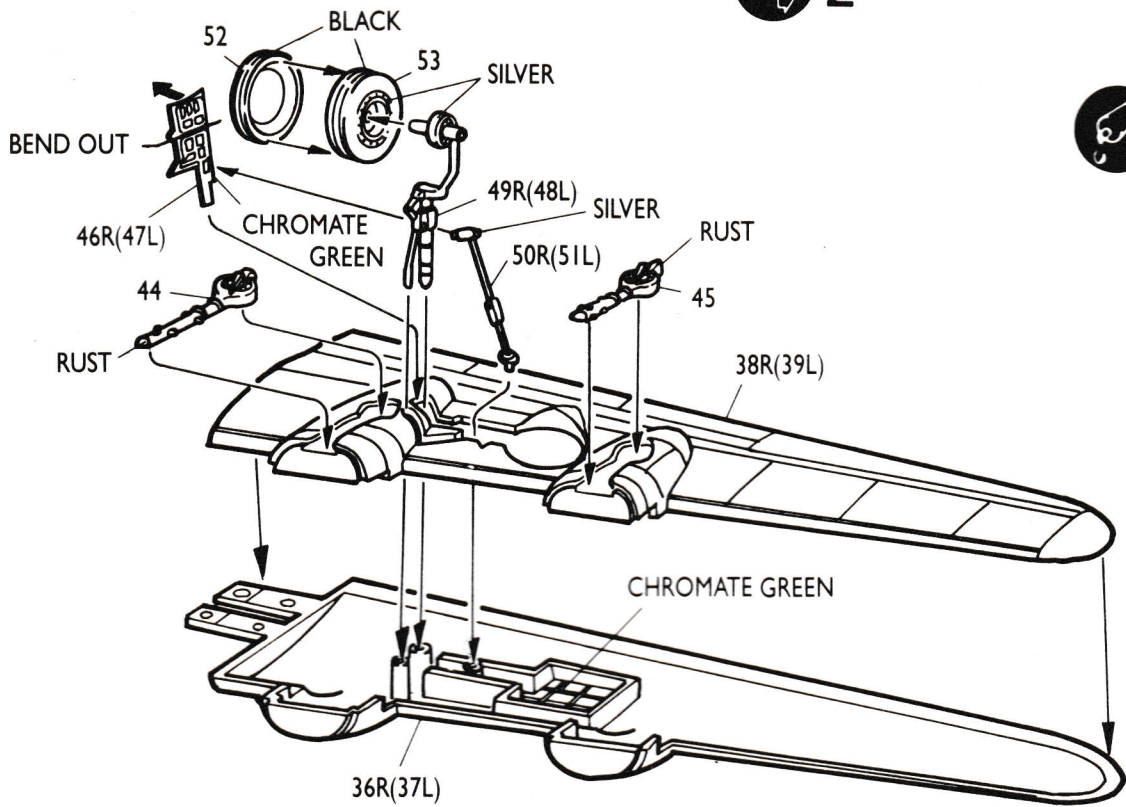

# 16 TAIL AND FINAL ASSEMBLY

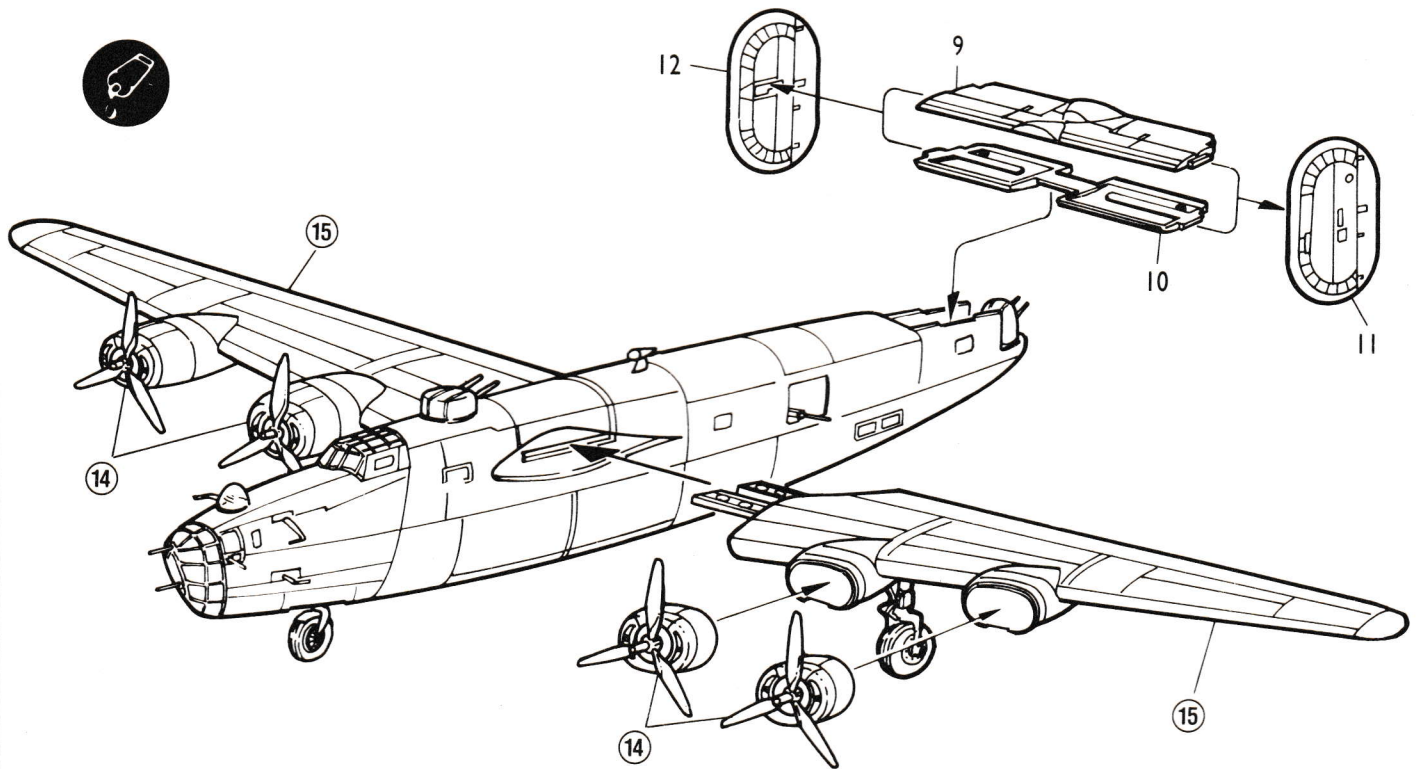

**PAINING AND DECAL PLACEMENT DIAGRAMS**

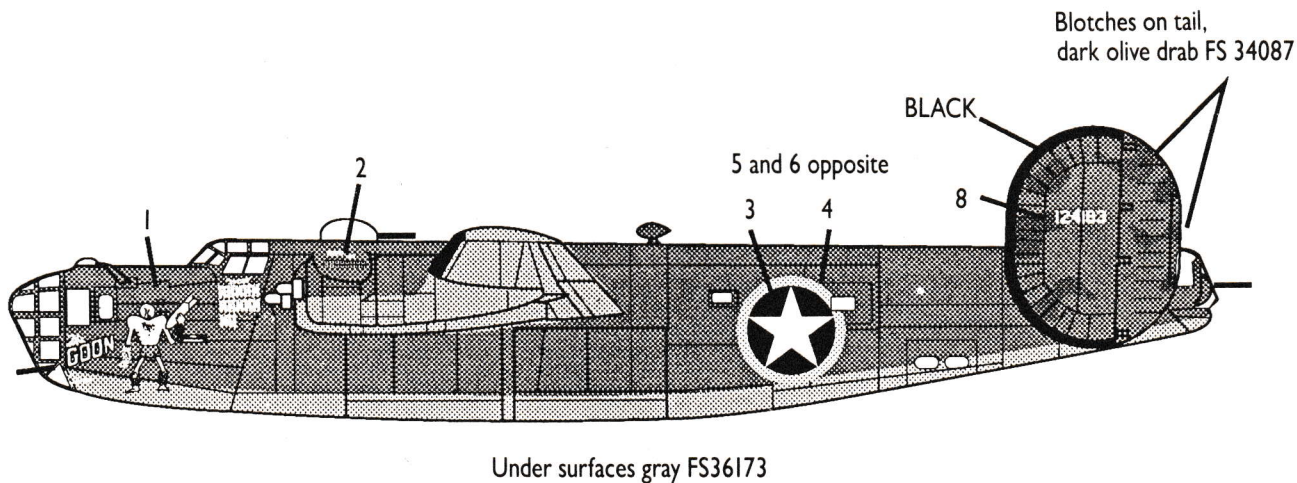
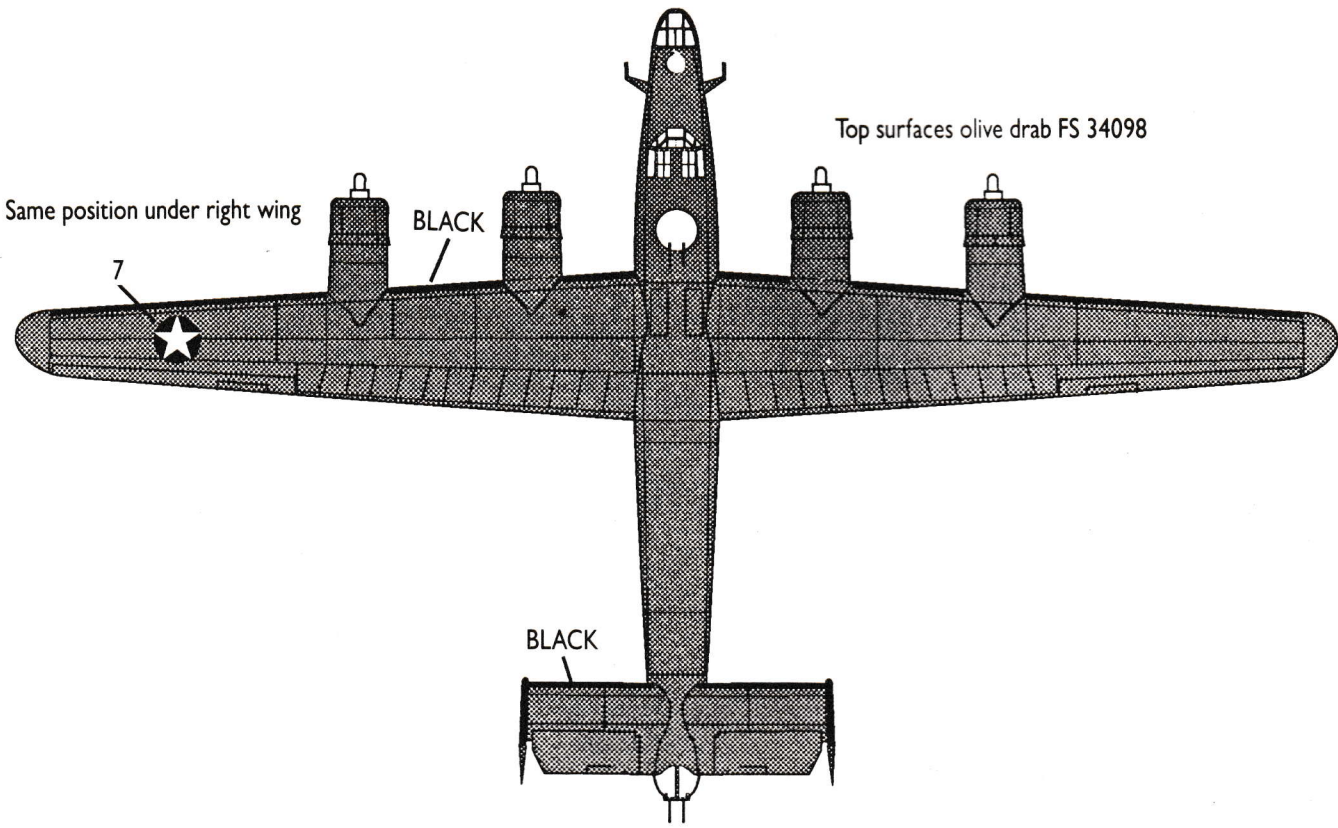

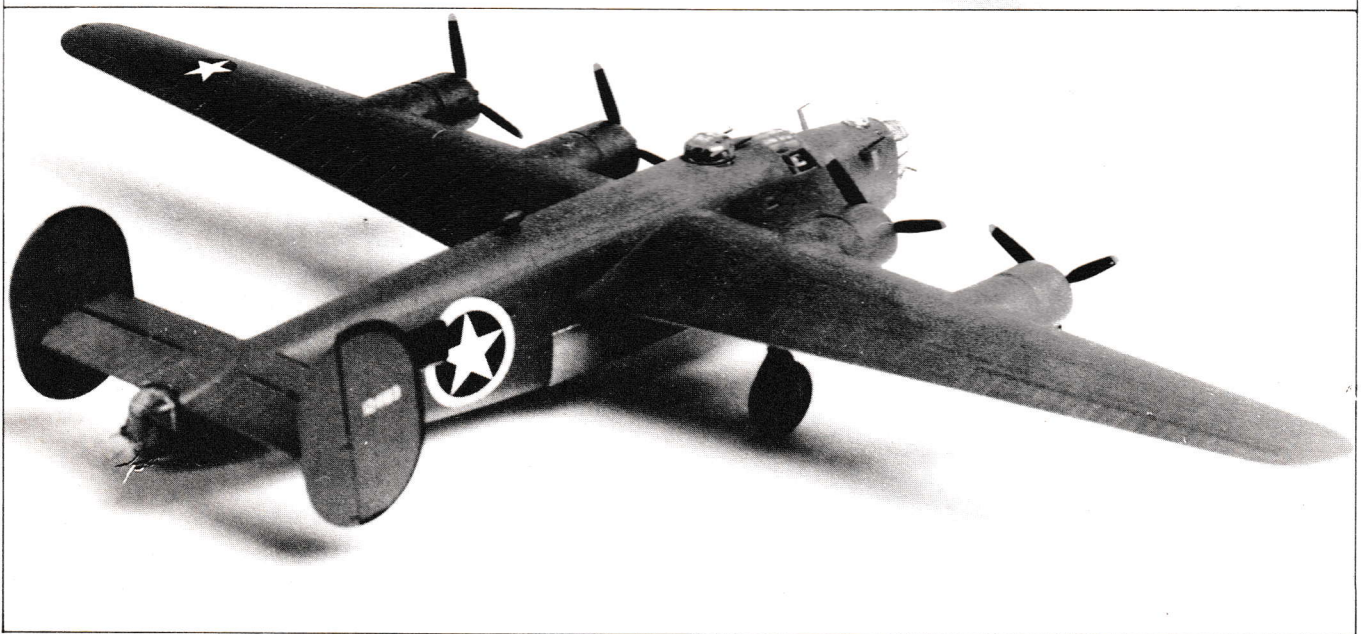
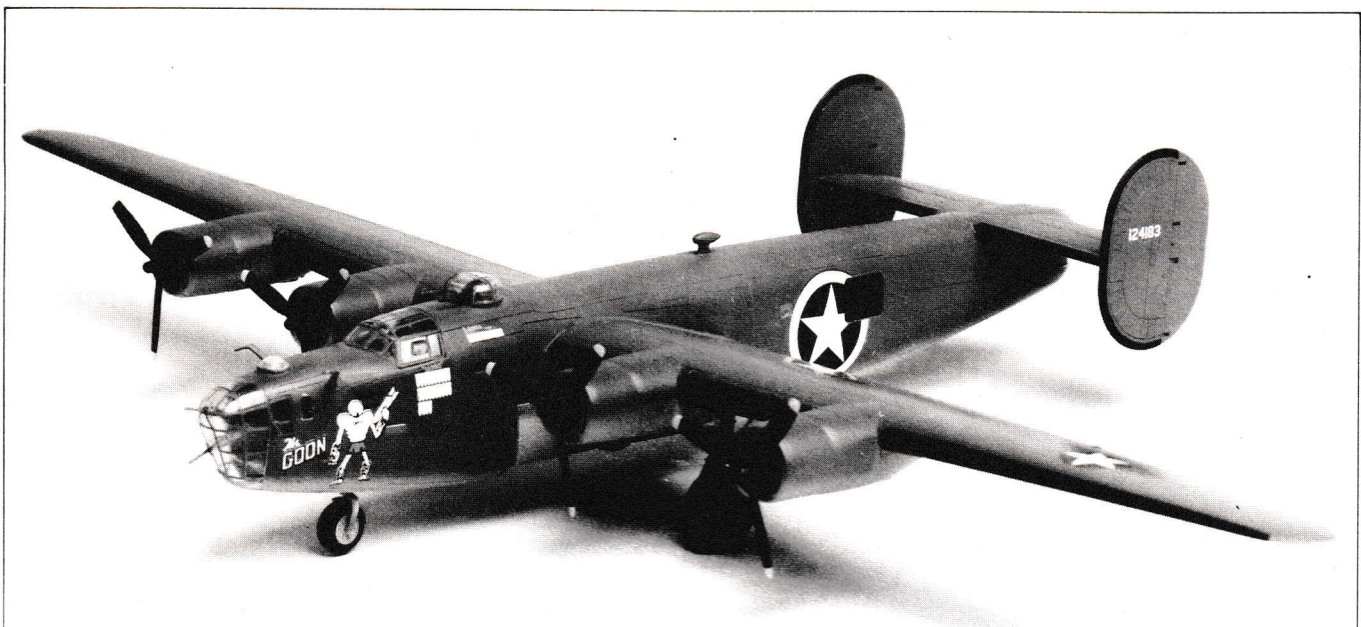

**ACADEMY**  
**MINICRAFT**  
MODEL KITS

**MINICRAFT MODELS, INC.**  
**P.O. BOX 3577 • TORRANCE, CA 90510**

ENGLISH	FRENCH	GERMAN	SPANISH	ITALIAN
WHITE	BLANCO	WEISS	BLANC	BIANCO
YELLOW	JAUNE	GELB	AMARILLO	GIALLO
RED	ROUGE	ROT	ROJO	ROSSO
BLUE	BLEU	BLAU	AZUL	BLU
GRAY	GRIS	GRAU	GRIS	GRIGIO
GUNMETAL	METALLIC	METALLIC	METALICO	METALLICO
GREEN	VERT	GRUN	VERDE	VERDE
SILVER	ARGENT	SILBERN	PLATA	ARGENTO
BLACK	NOIR	SCHWARZ	NEGRO	NERO
ORANGE	ORANGE	ORANGE	NARANJADO	ARANCIO
AMBER	AMBRE	BERNSTEINFARBEN	AMBAR	AMBRA
ALUMINUM	ALUMINIUM	ALUMINIUMFARBEN	ALUMINIO	ALLUMINIO
GLOSS	LUSTRE	GLANZENDES	BRILLANTE	BRILLANTE
FLAT	TERNE	GLANZLOSES	APAGADO	OPACO



Cement Parts  
Coller  
Kleben  
Pegar  
Incollare  
Colar  
Kleben



DO NOT cement  
Ne pas coller  
Nicht kleben  
No pegar  
Non incollare  
Nao colar  
Niet kleven



Cut away  
Couper  
Scheiden  
Cortar  
Tagliare  
Cortar  
Snijden



Optional parts  
Choix  
Auswahlmöglichkeit  
Eleccion  
Scelta  
Opcao  
Keuze



**3**

Repeat operation  
Répéter l'opération  
Vorgang wiederholen  
Repitir la operacion  
Ripetere  
Repitir a operação  
Herhalen