

MATCHBOX®

HANDLEY PAGE HALIFAX

1-72nd SCALE KIT

PK-604

Details BMKI.

Span 98 ft. 10 in. (30.12 m).

Length 70 ft. 1 in. (21.36 m).

Engines 4 x Merlin 10 of 1280 h.p.
with rotol constant speed
propellers.

Speed At 17500 ft. 265 m.p.h.
(5334.50 m-424 km/h)

Weight Max. 58,000 lb. (26308.36 kg).
Bomb load 13,000 lb.
(5896 kg).

Range 1,860 miles (2976 km).

Ceiling 22,800 ft. (6949 m).

Armament 2 x 303 Brownings in front,
4 x 303 in rear turret.

COLOUR PLAN

PLANCHE EN COULEURS

FARBPLAN

PLAN DE COLORES

SCHEMA DEI COLORI

塗装

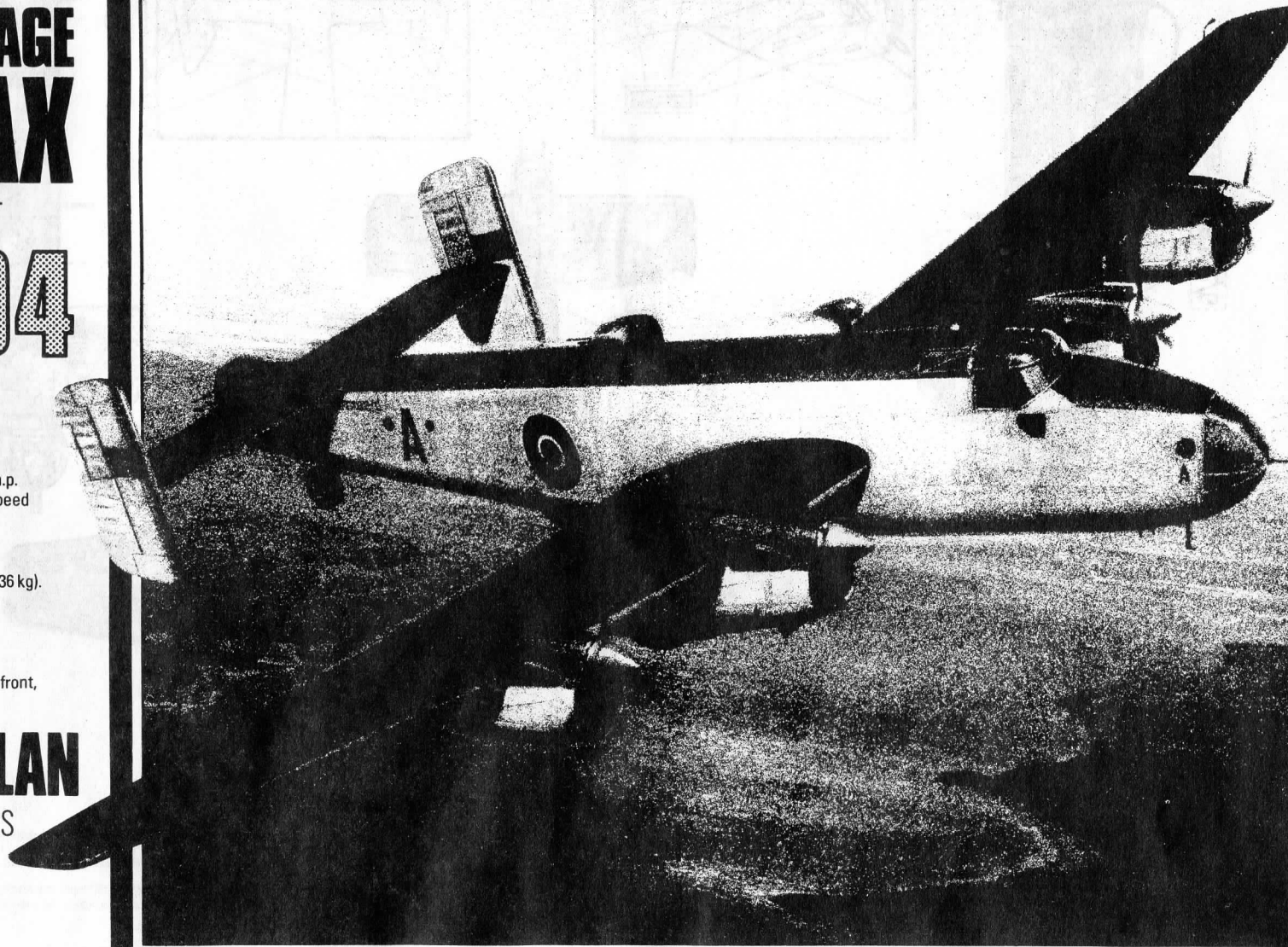

The Halifax, one of the truly famous aircraft of WW II, originated in reply to an Air Ministry spec. P. 13/36 calling for a bomber powered by 2 Rolls-Royce Vulture engines. A mock up was built, but as it was thought that the Vulture would not be available in sufficient quantities, the Air Ministry ordered on 3rd September, 1937 two prototypes powered by 4 Merlin engines, the first machine flying on 25th October, 1939. With a maximum speed of 265 m.p.h. and a bomb load of 13,000 lb. the BMKI entered service in November, 1940 and made its first sortie on the night of 10/11 March, 1941. Development was swift and as it was found that there were seldom frontal attacks by enemy fighters, the nose powered turret was removed and a streamlined nose fitted. Later versions had low-drag Boulton Paul 4-gun Dorsal turrets fitted, and even later aircraft were fitted with H2S Radar, larger fins and rudders. A general 'cleaning up' of the aircraft as well, increased its speed by some 20 m.p.h.

Le Halifax, un des avions les plus fameux de la Deuxième Guerre mondiale, fut conçu en réponse à une spécification P.13/16 du Ministère de l'Aviation relative à un bombardier propulsé par 2 moteurs Vulture Rolls Royce. Il en fut construit un modèle, mais comme on pensait que les moteurs Vulture ne seraient pas disponibles en quantités suffisantes, le Ministère de l'Aviation commanda, le 3 septembre 1937, deux prototypes actionnés par 4 moteurs Merlin, et le premier appareil vola le 25 octobre 1939. Avec une vitesse maximum de 426 km/h et une charge de bombes de 5.896 kg, le BMKI fut mis en service en novembre 1940 et effectua sa première sortie au cours de la nuit du 10/11 mars 1941. Le perfectionnement de cet appareil fut rapide et, comme on avait découvert que les attaques frontales par les avions de chasse ennemis étaient rares, on enleva la tourelle actionnée par le nez et l'on monta un tuyau flexible aérodynamique. Des versions subséquentes eurent des tourelles dorsales à 4 mitrailleuses Boulton Paul et à basse traînée; plus tard encore, les avions furent dotés de Radar H2S, de plans de dérive plus grands et de gouvernails. En outre, une mise au point générale de l'avion en augmenta la vitesse de quelque 32 km/h.

Die Halifax, eine der wirklich berühmten Maschinen des zweiten Weltkrieges, stammte aus einem Angebot auf die technische Beschreibung P.13/36 des Luftfahrtministeriums, bei der ein Bomber gefordert wurde, der mit zwei Vulture-Motoren von Rolls Royce ausgerüstet war. Ein Modell wurde gebaut, jedoch glaubte man, daß Vulture-Motoren nicht in ausreichenden Menger zur Verfügung stehen würden. Daher bestellte das Luftfahrtministerium am 3. September 1937 zwei Prototypen, die von 4 Merlin-Motoren angetrieben wurden. Die erste Maschine flog am 25. Oktober 1939. Bei einer Höchstgeschwindigkeit von 426 km/h und einer Bombenlast von 5.896 kg wurde die BMKI im November 1940 in Betrieb genommen und flog ihren ersten Einsatz in der Nacht vom 10. auf den 11. März 1941. Die Weiterentwicklung ging schnell vonstatten, und es wurde festgestellt, daß selten Frontalangriffe von feindlichen Maschinen stattfanden. Daher wurde der Geschützturm in der Kanzel entfernt und ein stromlinienförmiger Schlauch angebracht. Spätere Ausführungen hatten Dorsal-Geschütztürme mit vier Geschützen vom Typ Boulton Paul und noch spätere Maschinen waren mit H2S-Radar ausgerüstet, mit größeren Rippen und Rudern. Durch eine allgemeine 'Säuberung' der Maschine steigerte sich ferner ihre Geschwindigkeit um etwa 32 km/h.

L'aereo Halifax, uno degli aeroplani più famosi della Seconda Guerra mondiale, fu ideato quale responso ad una specifica P.13/16 del Ministero dell'Aviazione circa un bombardiere azionato da due motori "Vulture" Rolls Royce. Ne venne costruito un modello, ma siccome si credeva che i motori Vulture non sarebbero stati disponibili in quantità sufficienti, il Ministero dell'Aviazione ordinò, il 3 settembre 1937, due prototipi azionati da 4 motori Merlin; il primo apparecchio volò il 25 ottobre 1939. Con una velocità massima di 426 km/ora, ed un carico di bombe di 5.896 kg, il BMKI fu messo in servizio in novembre 1940 ed effettuò la sua prima sortita durante la notte del 10/11 marzo 1941. Il perfezionamento di questo aereo avvenne rapidamente e poichè si aveva scoperto che raramente accadevano attacchi frontali da parte di caccia nemici, venne rimossa la torretta azionata dal musone e piazzato un tubo flessibile aerodinamico. Versioni susseguenti ebbero torrette dorsali con 4 mitragliatrici Boulton Paul di bassa resistenza e, più tardi ancora, gli apparecchi vennero dotati di Radar H2S, di derive più grandi e di timoni di direzione. Inoltre, una rifinitura generale dell'aereo ne aumentò la velocità di circa 32 km/ora.

El Halifax, uno de los aviones más famosos de la Segunda Guerra Mundial, se originó como respuesta a una especificación de un Ministerio del Aire que solicitaba un Bombardero impulsado por 2 motores Rolls Royce "Vulture" (Buitre). Se construyó una maqueta, pero como se creyó que el motor "Vulture" no estaría disponible en cantidades suficientes, el Ministerio del Aire ordenó, el 3 de septiembre de 1937, la construcción de dos prototipos impulsados por 4 motores Merlin. el primero de los cuales voló el 25 de octubre de 1939. Con una velocidad máxima de 426 km/h y una carga de bombas de 5.896 kg, el BMKI entró en servicio en noviembre de 1940 e hizo su primera salida en la noche del 10 al 11 de marzo de 1941. Su desarrollo fue rápido, y como se encontró que rara vez se efectuaban ataques frontales por parte del enemigo, se quitó la torrecilla mecánica del morro del avión y se colocó una manga aerodinámica. Versiones posteriores tenían torrecillas dorsales para 4 ametralladoras, Boulton Paul, de baja resistencia; y aviones más posteriores aún llevaban Radar H2S, aletas más grandes y timones de dirección. Un perfeccionamiento general del avión aumentó su velocidad en 32 km/h.

ハンドレイ・ページ・ハリファックス このハリファックスは、第二次大戦時の最も有名な飛行機の一つです。元来、航空省の特別追撃機P 13/36にロールス・ロイスのヴァルチユア・エンジン二基をつけた爆撃機用として製作されたものである。実物大模型が作られたが、ヴァルチユア・エンジンでは充分でないと考えられたので、航空省では、1937年9月3日に4基のマーリン・エンジン付の模範型を二機注文し、1939年10月25日に第一号機の初飛行がなりました。最高時速424 km, 爆弾積載量約5,897 kgで1940年11月から任務に就きました。そして、1941年3月10日から11日にかけての夜初出撃しました。敵機の正面攻撃は非常にまれなことから、回転式砲塔式の機首は、流線形の機首に取り換える等、速やかな改善がなされました。後に抵抗力ポウルトン・ポウル背面回転式砲塔が4台付けられ更に後にはH-2-Sレーダーや更に大きな垂直安定板、方向かじなどが取付けられました。一般的な点検・手入れにより時速32 kmも増しました。ハリファックスは戦闘機としてあらゆる面に使用され活躍したが、パラシュート秘密部隊を敵地に送り込む役目もし、すべて任務を立派に果しました。

NAME AND ADDRESS
(BLOCK CAPITALS)

MY COMPLAINT IS





RETURN TO (UK ONLY)
CONSUMER SERVICE DEPT.
LESNEY PRODUCTS & CO. LTD.
SWAINS INDUSTRIAL ESTATE,
ASHINGTON ROAD,
ROCHFORD, ESSEX, ENGLAND.

PK-604

Paint required parts before assembly. Assemble parts in sequence. Black numbers in circle indicate part number. Black numbers in star indicate completed section. Before joining fuselage halves, clear holes 'A' (When shown).
 Peindre les pièces nécessaires avant le montage. Monter les pièces dans l'ordre indiqué. Les numéros noirs encadrés indiquent la pièce numérotée. Les numéros noirs dans une étoile indiquent la section terminée. Avant de joindre les deux moitiés du fuselage, dégager les trous 'A' (lorsqu'ils sont indiqués).

Benötigte Teile vor Zusammenbau anmalen. Teile der Reihe nach wie gezeigt zusammenbauen. Schwarze Zahlen im Kreis geben den nummerierten Teil an. Schwarze Zahlen im Stern geben den fertigen Abschnitt an. Vor Zusammensetzung der Rumpfhälften, Löcher 'A' freimachen (wenn gezeigt).
 Pitturare i pezzi necessari prima del montaggio. Montate i pezzi nell'ordine indicato. I numeri neri nel cerchio indicano la parte numerata. I numeri neri in una stella indicano la sezione finita. Prima di congiungere le due metà della fusoliera, sbloccate i fori 'A' (quando sono indicati).
 Las piezas necesitan pintura antes de su montaje. Montense las piezas según la secuencia indicada. Los numeros negros en un círculo indican el numero de pieza. Los numeros negros en una estrella indican la seccion completa. Antes de unir las dos mitades del fuselaje, limpiense los orificios 'A' (cuando se marquen).

下図の部分は組立て前に色を塗り、黒字の数字に従って、まず小さな部品を組立て、さらに黒印の白ぬき数字に従って全体を組立てる。2つの半分の胴体を付け合わせる前に、穴“A”が汚れている時はきれいにする。

 <p>CEMENT PARTS TOGETHER COLLER ENSEMBLE LES PIÈCES TEILE ZUSAMMENKLEBEN ATTACCARE I PEZZI CON ADESIVO UNIR LAS PIEZAS CON ADESIVO 部品を接着する。</p>	 <p>DO NOT CEMENT TOGETHER NE PAS COLLER ENSEMBLE NICHT ZUSAMMENKLEBEN NON ATTACCARE CON ADESIVO NO UNIR LAS PIEZAS CON ADESIVO 一つになるように接着しない。</p>	 <p>ALTERNATIVE PART PROVIDED AUTRE VERSION POSSIBLE WAHLWEISE MIT ANDEREM TEIL PEZZO ALTERNATIVO PIEZA ALTERNATIVA PROVISTA とちらかを選択する部品がある。</p>	 <p>WITHOUT STAND, ADD NOSE WEIGHT. S'IL N'Y A PAS DE SUPPORT, IL FAUT ALOURDIR LE NEZ. OHNE STAND, FLUGZEUGKANZEL BESCHWEREN. SE NON VI È UN SUPPORTO, OCCORRE APPESANTIRE IL NASO. DE NO IR SOBRE UN SOPORTE EXHIBIDOR, DEBE ANADIRSE PESO AL MORRO. スタントを使用しない時は機首に重りをいれる。</p>
--	---	---	--

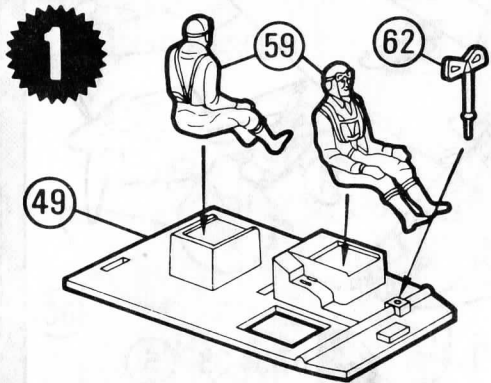

1 62.59-49

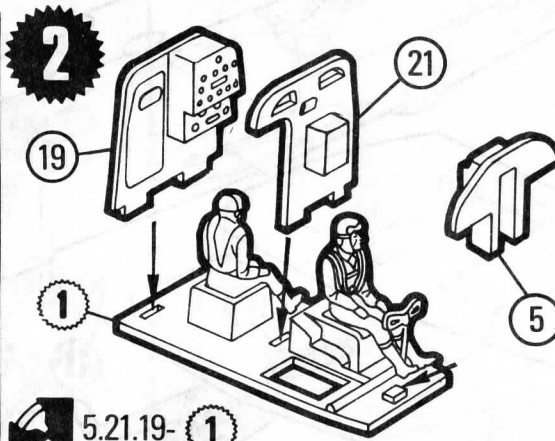

2 5.21.19-1

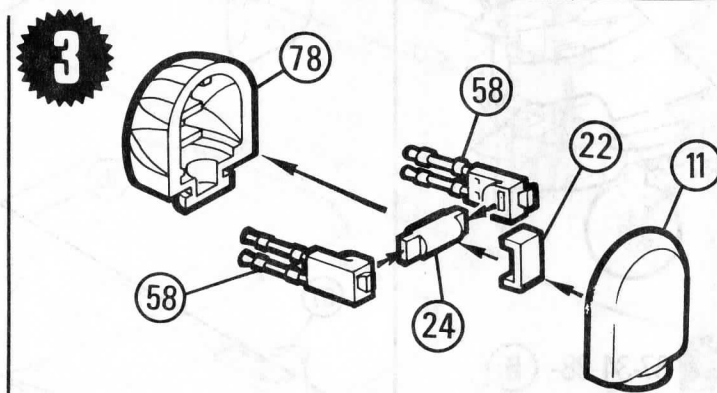

3 58-24 22-[X]24.58]-78 11-78

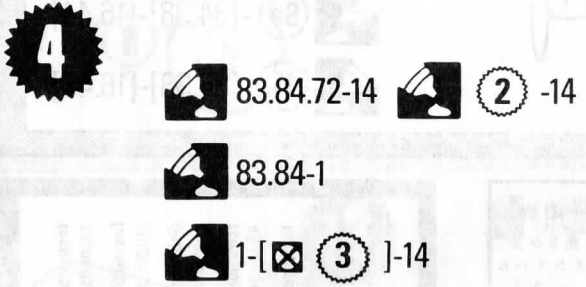

4 83.84.72-14 2-14
 83.84-1
 1-[X]3]-14

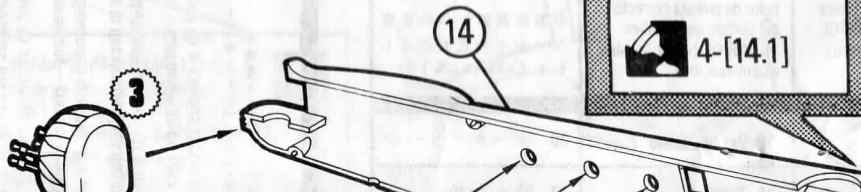
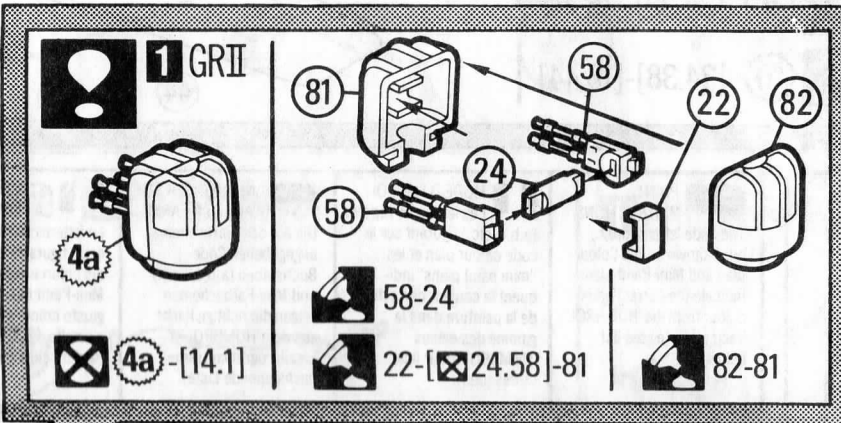

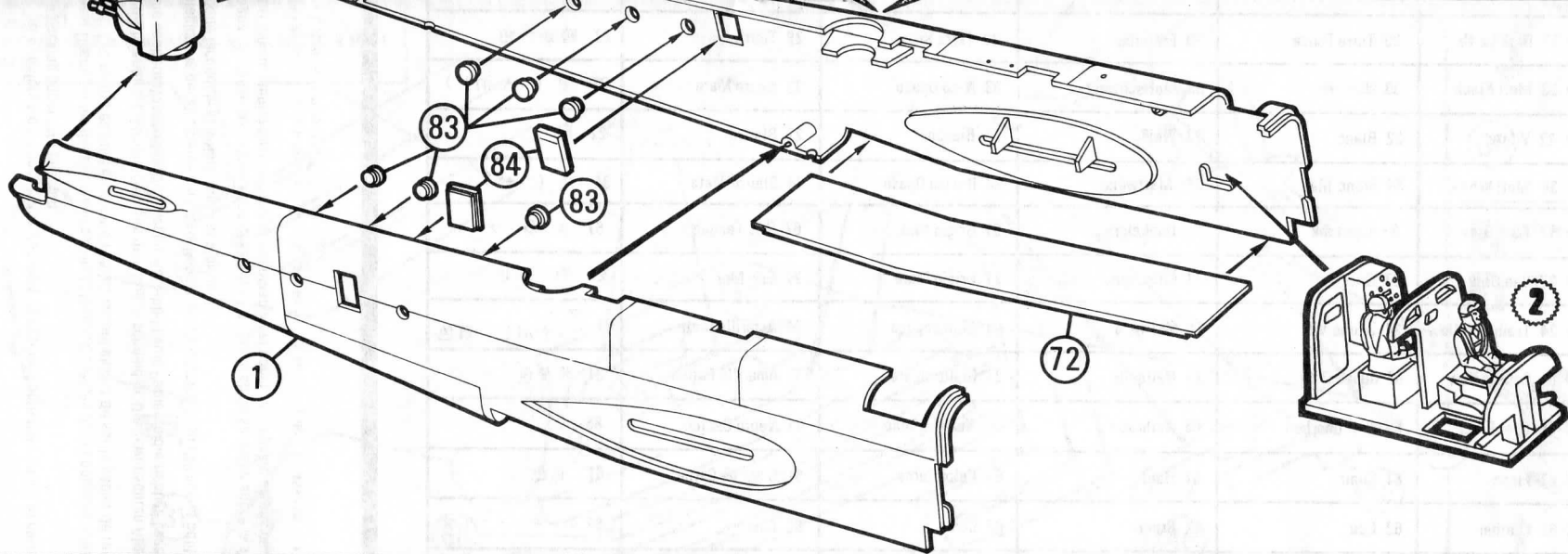

5



2 BI
3 BII

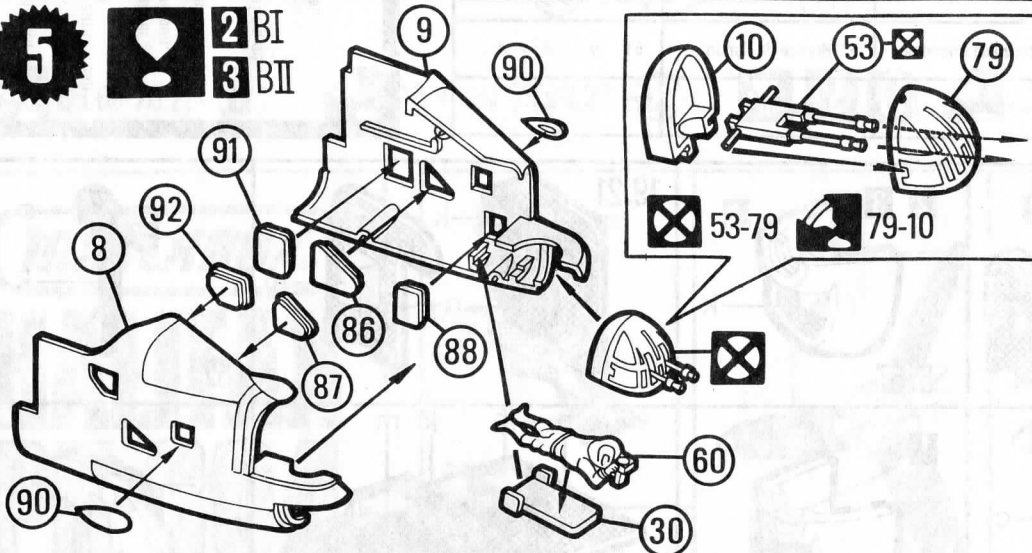

86.88.90.91-9 87.90.92-8 60-30-9 9-[10.79]-8



1 GR II Series 1A No.58 Squadron

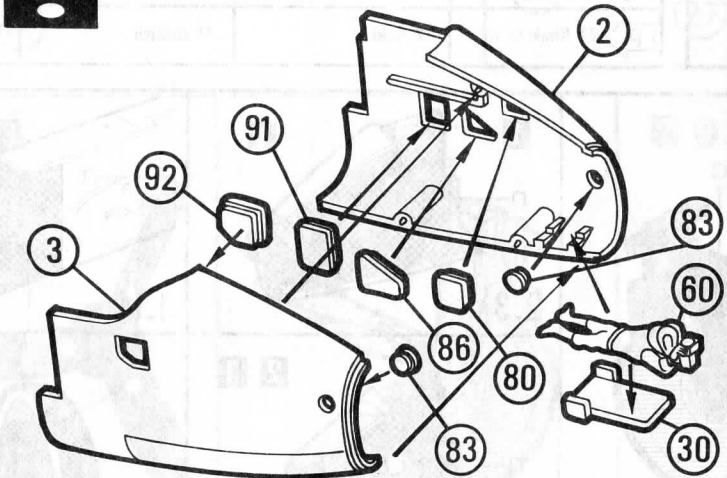

80.83.86.91-2 83.92-3 60-30-2 2-3

6



2 BI No.76 Squadron

3 BII No.10 Squadron

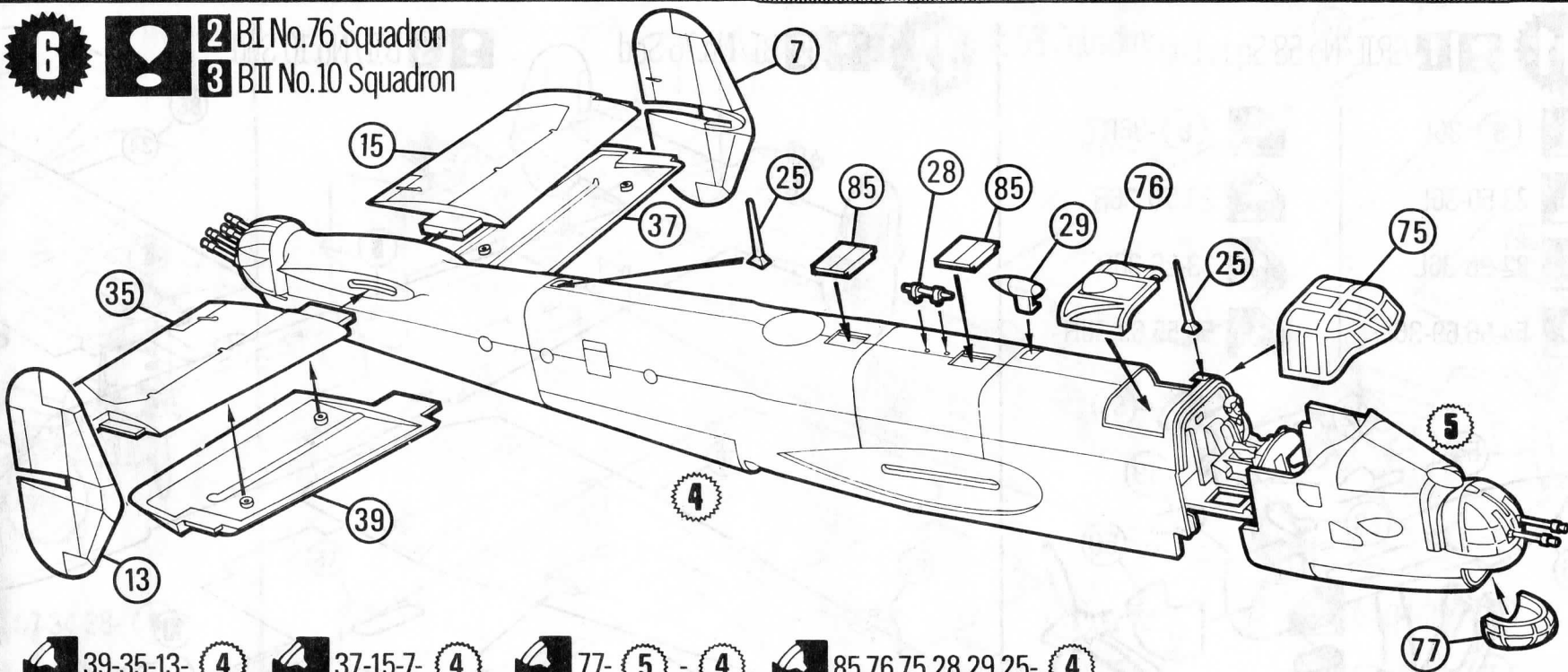

39-35-13-

37-15-7-

77- -

85.76.75.28.29.25-



1 GRII Series 1A No.58 Squadron

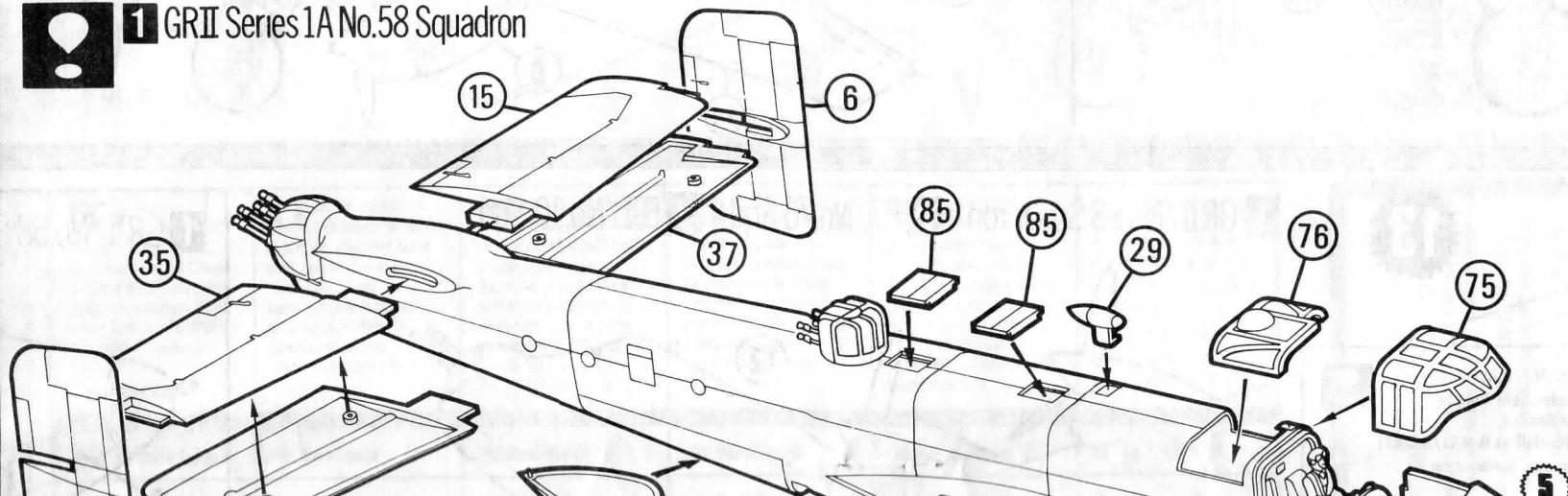

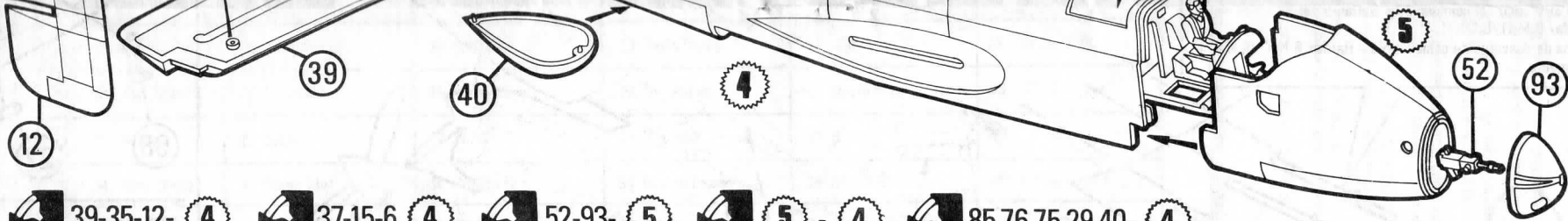

- 39-35-12- 4
- 37-15-6 4
- 52-93- 5
- 5 - 4
- 85.76.75.29.40- 4

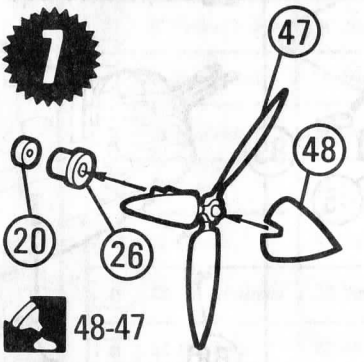

- 48-47
- 47 [26]-20

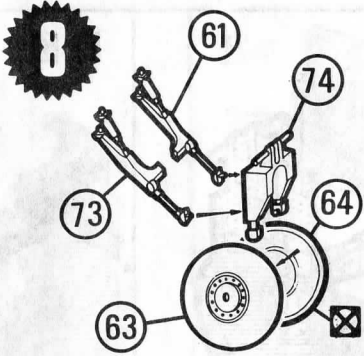

- 63-64 [63-64]-74
- 61.73-74

9 2 BI/No.76 Sqd 3 BII/No.10 Sqd

- 7 -56-41-17
- 54.55.69-41
- 7 -56-42-18
- 54.55.69-42

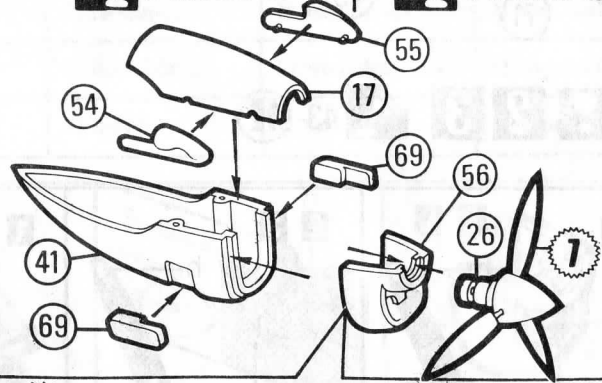

9a 1 GRII
No.58 Squadron

- 17-26-51-41
- 54.55.69-41
- 18-26-51-42
- 54.55.69-42

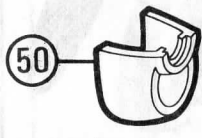





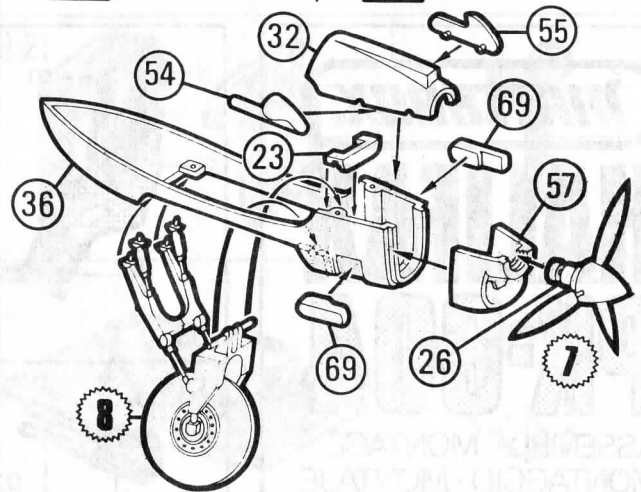



10 2 BI/No.76 Sqd 3 BII/No.10 Sqd

- 8 -36L
- 23.57-36L
- 32-26-36L
- 54.55.69-36L
- 8 -36R
- 23.57-36R
- 33-26-36R
- 54.55.69-36R



11

1 GRII/No.58 Squadron

- | | |
|--|---|
|  8 -36L |  8 -36R |
|  23.50-36L |  23.50-36R |
|  32-26-36L |  33-26-36R |
|  54.55.69-36L |  54.55.69-36R |

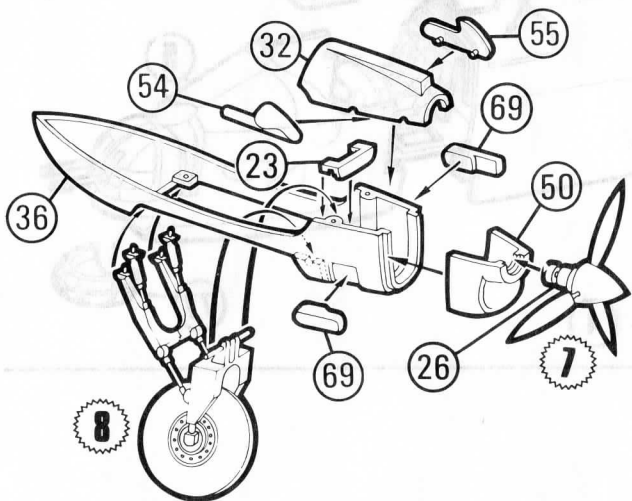

12

2 BI/No.76 Sqd

3

BII/No.10 Sqd

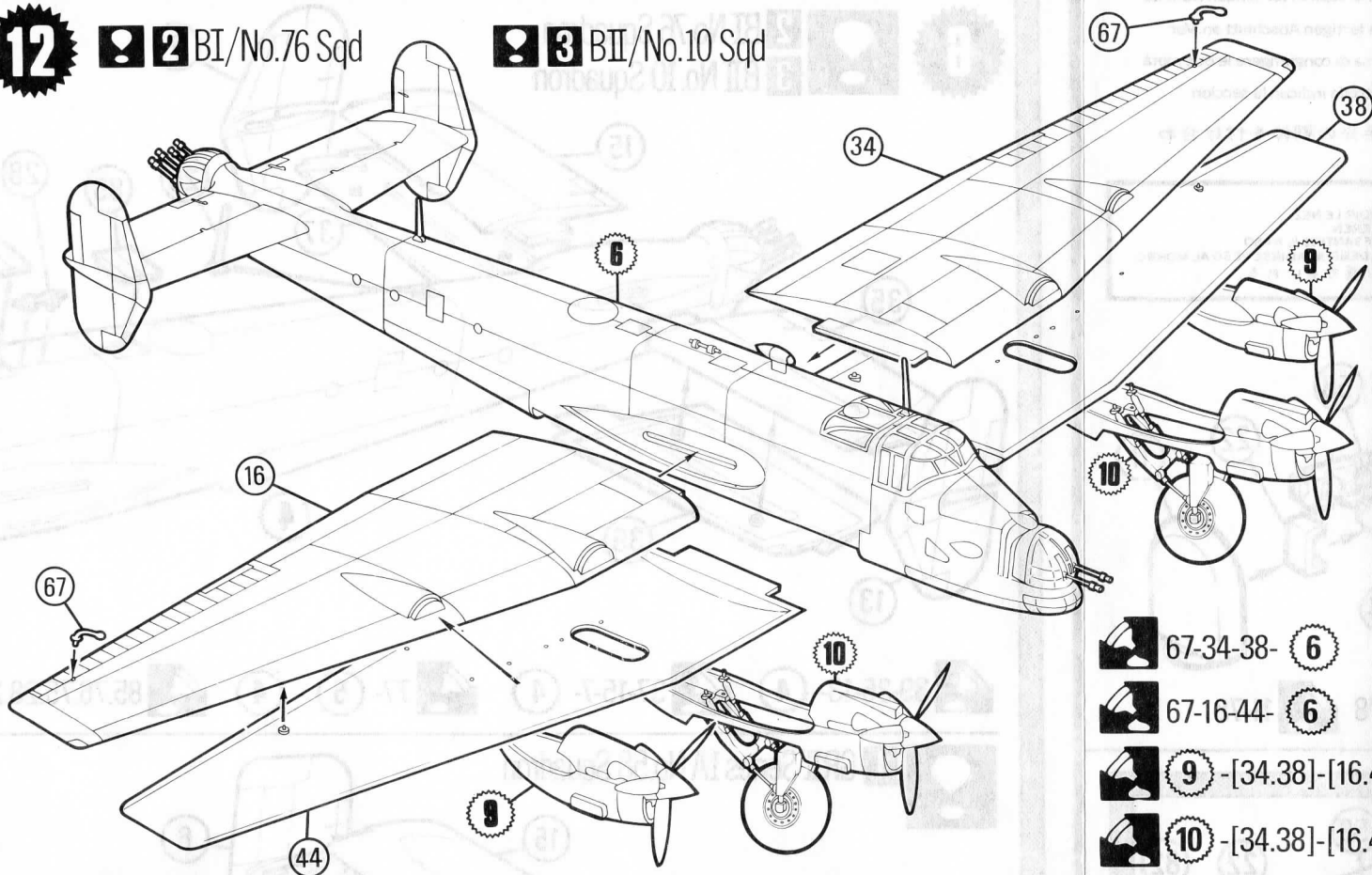

- | |
|--|
|  67-34-38-  6 |
|  67-16-44-  6 |
|  9 -[34.38]-[16.44] |
|  10 -[34.38]-[16.44] |

13**1** GR II/No.58 Squadron **2** BI/No.76 Sqd **3** BII/No.10 Sqd

Fuel dump pipes. Halifax B.MK1/B.MK11 only.
 Tuyaux de décharge de combustible. Pour le
 Halifax B.MK1/B.MK11 seulement.
 Treibstofflagerrohre. Nur für Halifax B.MK1/B.MK11.
 Tubi di scarico del combustibile. Soltanto per il
 Halifax B.MK1/B.MK11.
 Tubos de descarga de combustible - Halifax B.MK1/B.MK11
 solamente.

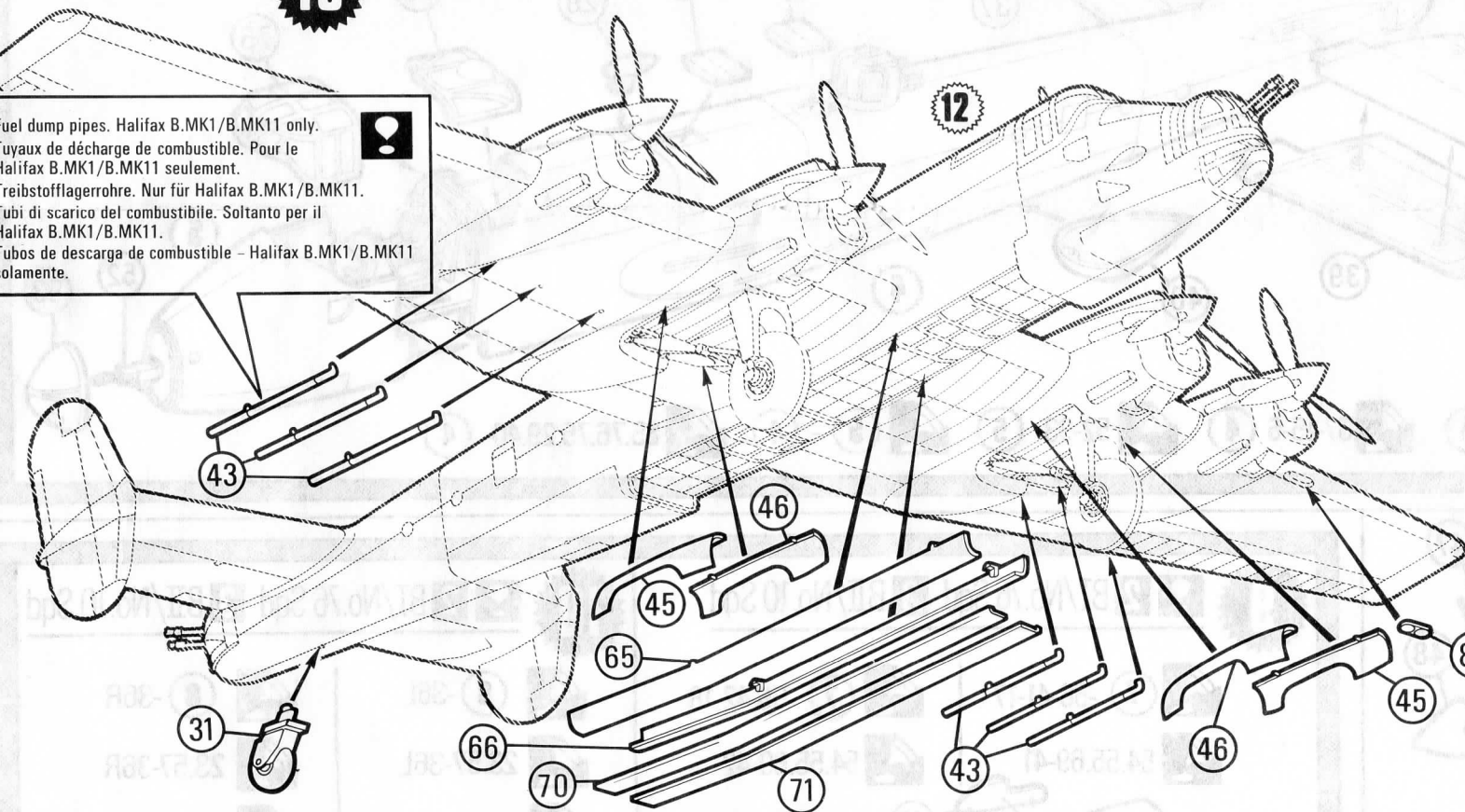
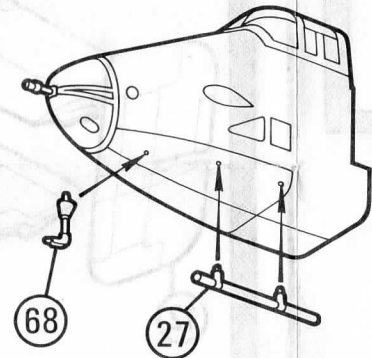
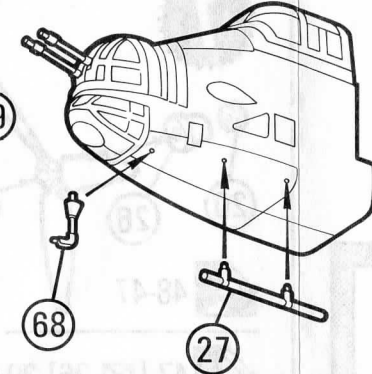
**1** GR II/No.58 Squadron**2** BI/No.76 Sqd
3 BII/No.10 Sqd

PAINT
 INST
 The code letter
 etc.) shown on
 plan and Mini-h
 indicate the co
 colour from the
 Enamel range (s
 below).

- a** 30 Da
- b** 29 Da
- c** 33 Ma
- d** 22 W
- e** 34 Ma
- f** 67 Ta
- g** 27 Se
- h** 24 Tra
- i** 81 Pa
- k** 85 Co
- l** 61 Fle
- m** 62 Le
- n** 78 Co
- o** 53 Gu
- p** 72 KH

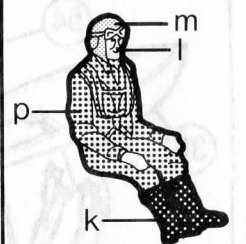
 65.66.70.71- **12** 45.46.31.89.68.27 **12** **2 3** 43- **12****MATCHBOX****HALIFAX
PK-604**ASSEMBLY · MONTAGE
MONTAGGIO · MONTAJE

59

53.58.52

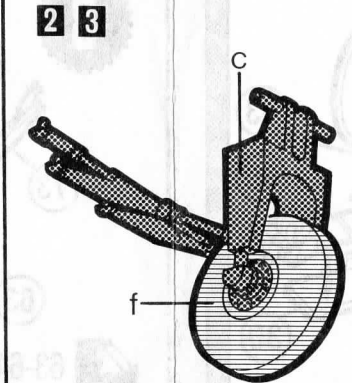
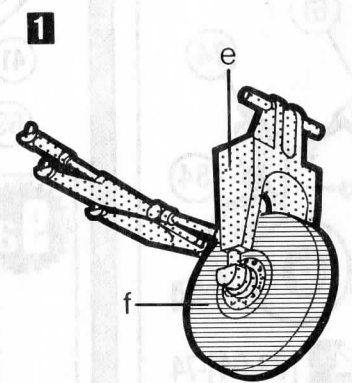
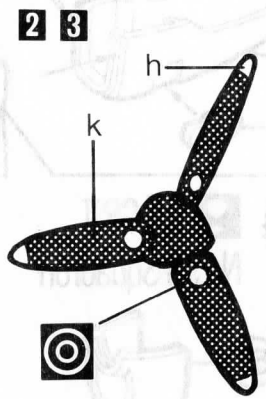
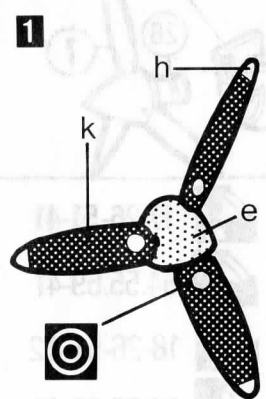
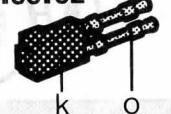

PAINT INSTRUCTIONS

The code letters (a,b,c, etc.) shown on the Colour-plan and Mini-Paint plans indicate the correct paint colour from the 'HUMBROL' Enamel range (see list below).

MODE D'EMPLOI

Les lettres de repères (a,b,c, etc.) figurant sur le code couleur plan et les "mini paint plans" indiquent la couleur correcte de la peinture dans la gamme des émaux 'HUMBROL' (voir liste ci-dessous).

ANLEITUNGEN ZUR WAHL DER FARBE

Die auf dem Farbschema angegebenen Code-Buchstaben (a,b,c, usw.) und Mini-Farbschemen zeigen die richtige Farbe aus dem 'HUMBROL' - Emailprogramm (siehe nachstehende Liste).

ISTRUZIONI PER LA VERNICIATURA

Le lettere codice (a,b,c, ecc.) figuranti sulla tabella dei colori e sulle tabelle Mini-Paint indicano il giusto colore della vernice a smalto serie 'HUMBROL' (vedere elenco in basso).

INSTRUCCIONES SOBRE LA PINTURA

Las letras de código (a,b,c, etc.) indicadas en la Cartilla de Colores y en las Minicartillas indican el color de pintura correcto del surtido de Esmaltes 'HUMBROL' (véase la lista a continuación).

ペンキの表示

ミニ・ペンキ表及びカラー表に示されている記号 (a , b , c , 等) はハンプロ・エナメル製品の範囲からの正確なペンキの色を表示します。(下の表をご覧下さい)

a	30 Dark Green	30 Vert Foncé	30 Dunkelgrün	30 Verde Scuro	30 Verde Oscuro	30 ダークグリーン
b	29 Dark Earth	29 Terre Foncé	29 Erdfarbe	29 Terra Scura	29 Tierra	29 暗かつ色
c	33 Matt Black	33 Noir Mat	33 Mattschwarz	33 Nero Opaco	33 Negro Mate	33 黒 (つや消し)
d	22 White	22 Blanc	22 Weiß	22 Bianco	22 Blanco	22 白
e	34 Matt White	34 Blanc Mat	34 Mattweiss	34 Bianco Opaco	34 Blanco Mate	34 白 (つや消し)
f	67 Tank Grey	67 Gris tank	67 Dunkelgrau	67 Grigio tank	67 Gris Tanque	67 タンク・グレイ
g	27 Sea Grey	27 Gris	27 Mittelgrau	27 Grigio Mare	27 Gris Mar	27 海・灰色
h	24 Trainer Yellow	24 Jaune Vif	24 Mattgelb	24 Giallo opaco	24 Amarillo Mate	24 マット (つや消し) 黄色
j	81 Pale Yellow	81 Jaune Clair	81 Hellgelb	81 Giallo chiaro	81 Amarillo Pálido	81 薄黄色
k	85 Coal Black	85 Noir Charbon	85 Anthrazit	85 Nero carbone	85 Negro Carbón	85 黒
i	61 Flesh	61 Chair	61 Haut	61 Color Carne	61 Color de Carne	61 肌色
m	62 Leather	62 Cuir	62 Braun	62 Cuoio	62 Cuero	62 カーキー・ドリル
n	78 Cockpit Green	78 Vert Cockpit	78 Cockpitgrün	78 Verde carlinga	78 Verde 'Cockpit'	78 コックピット・グリーン
o	53 Gun Metal	53 Gris Métal	53 Eisen Metallic	53 Bronzo da Cannone	53 Bronce de Cañón	53 ガンメタル
p	72 Khaki Drill	72 Kaki	72 Drillich	72 Color kaki	72 Caqui Drill'	72カーキー・ドリル

Instructions. Waterslide transfers. Cut transfers from sheet. Place transfers as required onto the surface of clean water for 45 seconds (approx) slide transfer off backing paper into position.

Instructions pour les décalcomanies. Découper les décalcomanies dans la feuille. Poser les décalcomanies voulues sur de l'eau propre pendant 45 secondes environ. Les mettre ensuite en position en les faisant glisser de sur le papier de renfort.

Gebrauchsanweisung — Wasserigel-Abziehbilder. Abziehbilder aus dem Bogen schneiden. Die gewünschten Abziehbilder ungefähr 45 Sekunden lang auf eine saubere Wasseroberfläche legen. Abziehbild vom Papier in die richtige Lage schieben.

Istruzioni per le decalcomanie. Ritagliare le decalcomanie dal foglio. Ponete quelle occorrenti su dell'acqua pulita per circa 45 secondi. Mettetele poi in posizione facendo scivolare dalla carta di rinforzo.

Instrucciones de agua. Cortense las calcomanias de la hoja. Ponganse como se desea sobre la superficie de agua limpia por 45 segundos (aproximadamente) desprendase la calcomania del papel de respaldo en posición.

トランスファー (デカール) の使い方はシートからトランスファーを切り取り、きれいな水に約45秒間つけた後、トランスファーを台紙からすへらしなからはりつける。

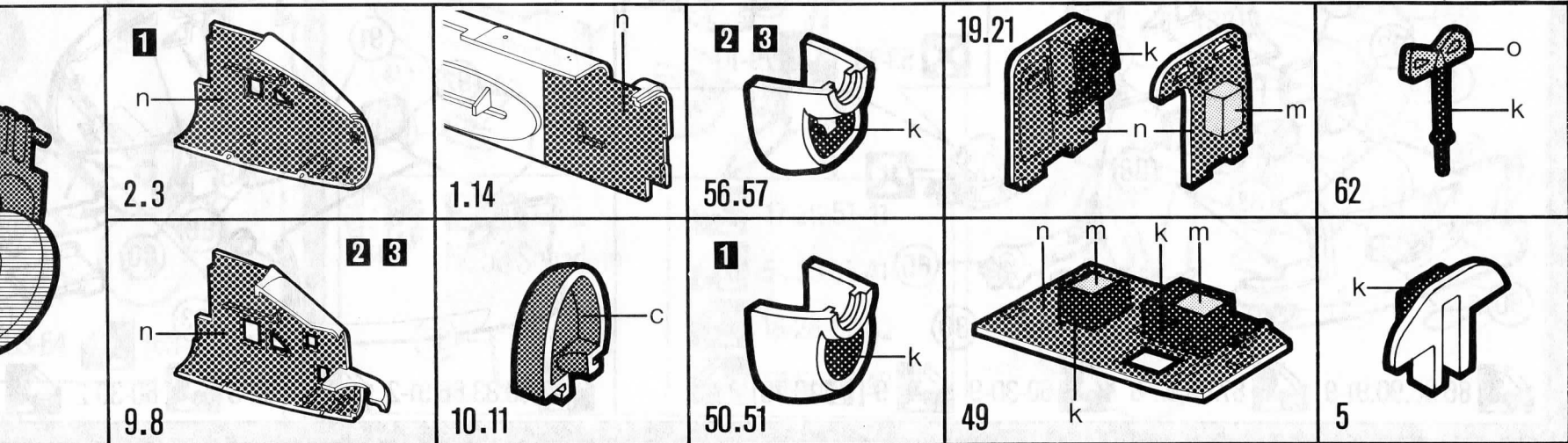



APPLY WATERSLIDE TRANSFER
APPLIQUER LE DECALQUE APRES L'AVOIR TREMPÉ DANS DE L'EAU
WASSERGLEITABZIEHBILDER ANBRINGEN
APPLICARE LA DECALCOMANIA DOPO AVERLA IMMERSA
NELL'ACQUA
APLICAR CALCOMANIA DESPUES DE SUMERGIRO EN AGUA
ウォーターズライド・トランスファー（テカール）
を使う

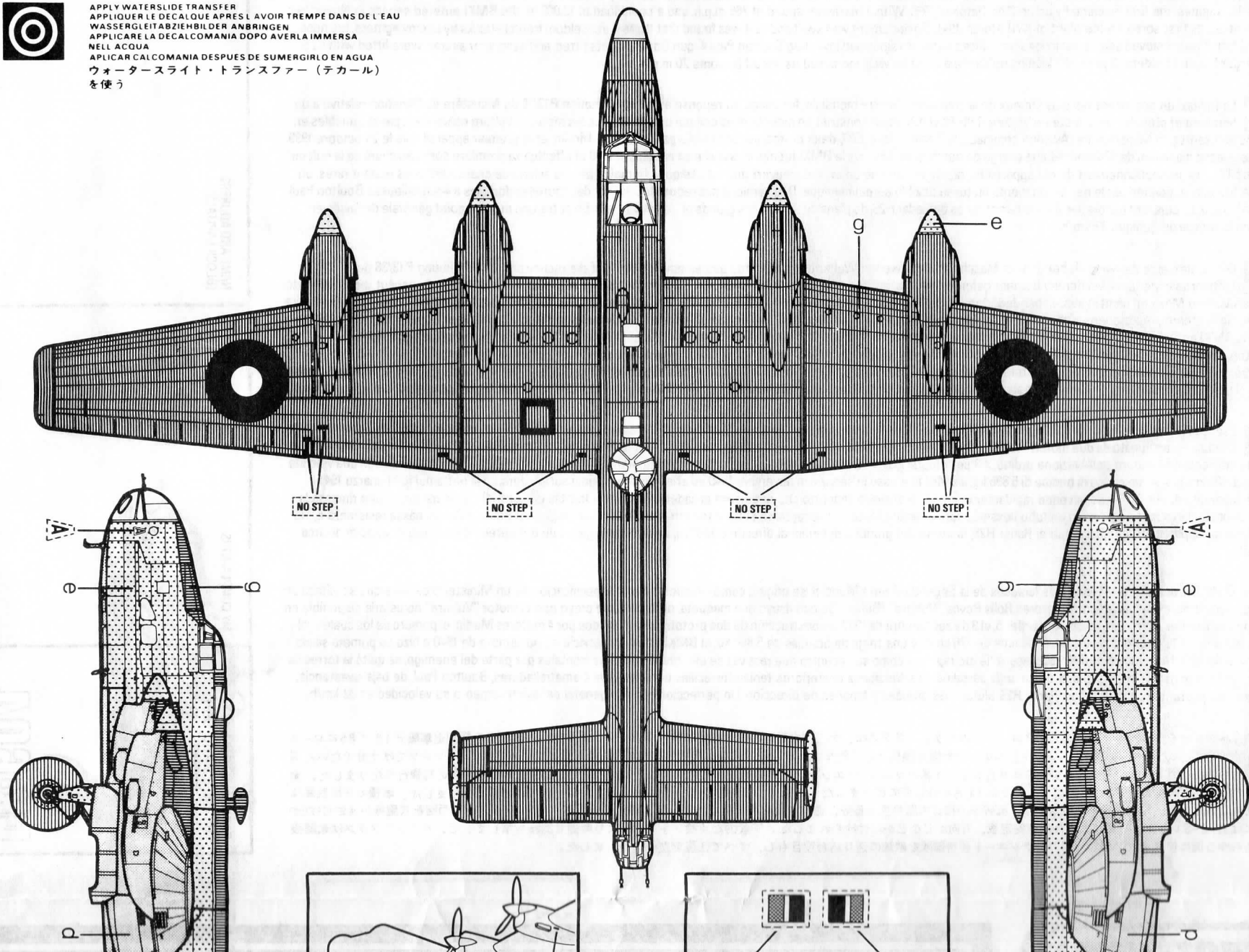

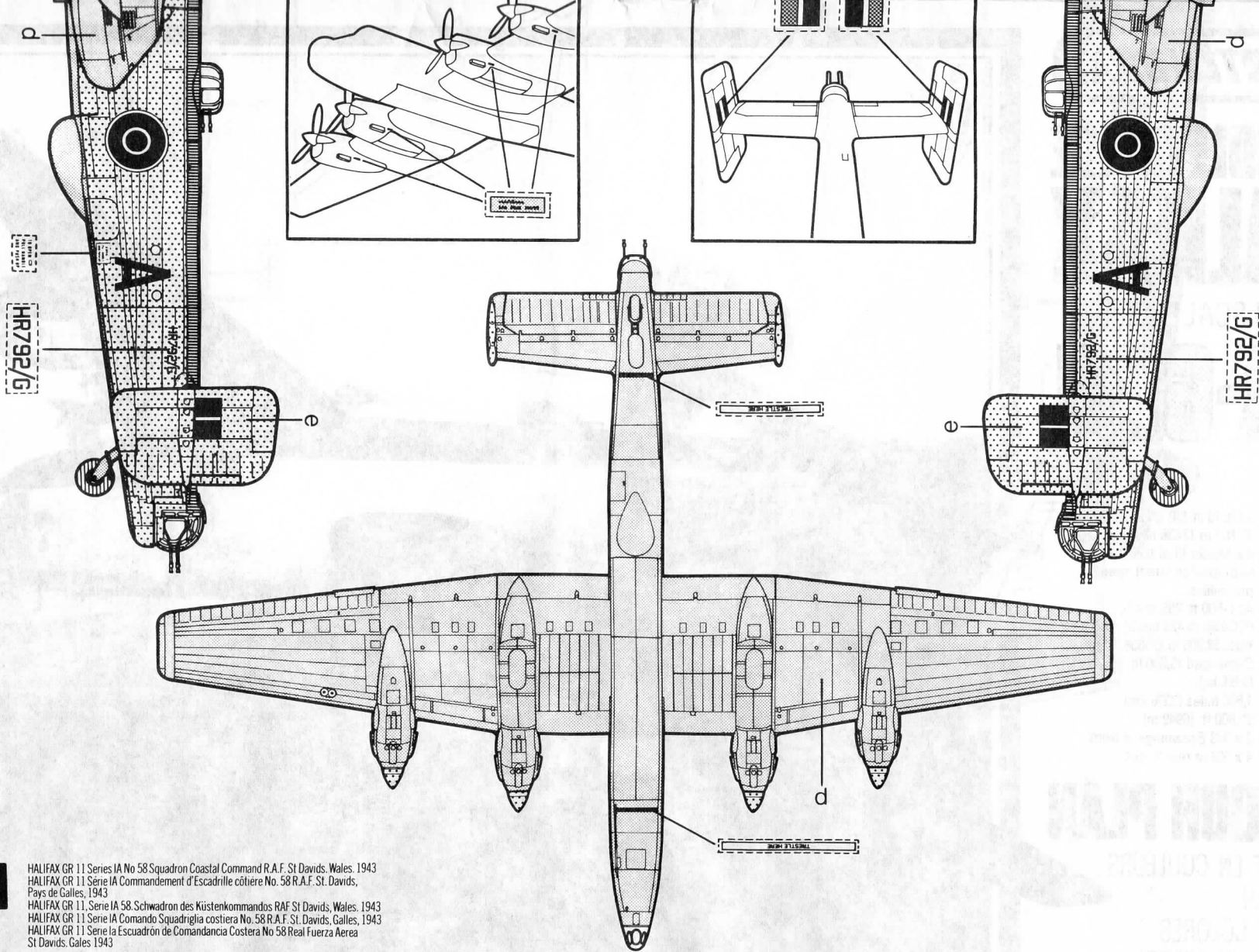

1

HALIFAX GR 11 Serie IA No 58 Squadron Coastal Command R.A.F. St Davids, Wales, 1943
 HALIFAX GR 11 Serie IA Commandement d'Escadrille c6tere No. 58 R.A.F. St. Davids,
 Pays de Galles, 1943
 HALIFAX GR 11, Serie IA 58. Schwadron des K6stenkommandos RAF St Davids, Wales, 1943
 HALIFAX GR 11 Serie IA Comando Squadriglia costiera No. 58 R.A.F. St. Davids, Galles, 1943
 HALIFAX GR 11 Serie Ia Escuadron de Comandancia Costera No 58 Real Fuerza Aerea
 St Davids, Gales 1943

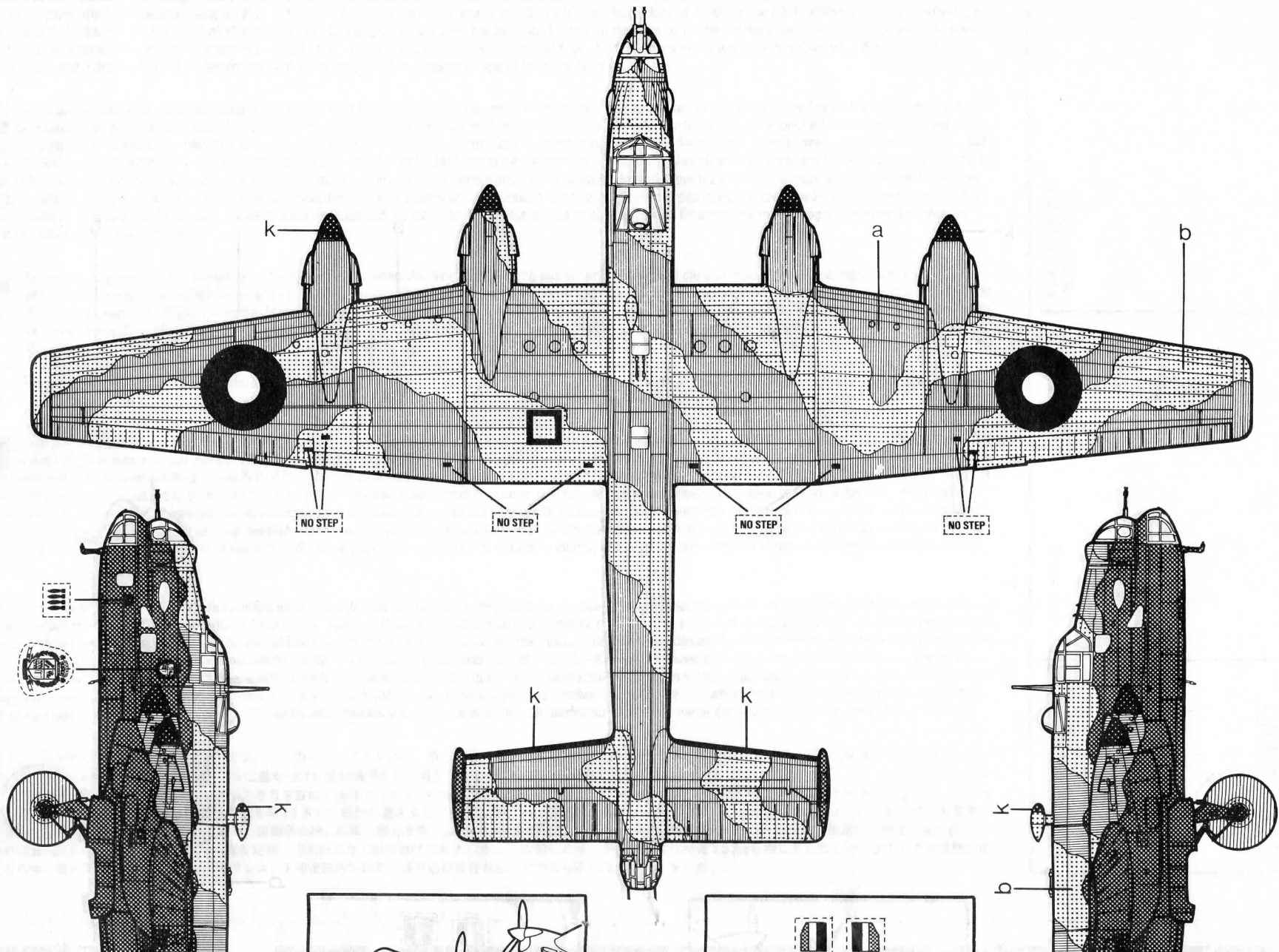

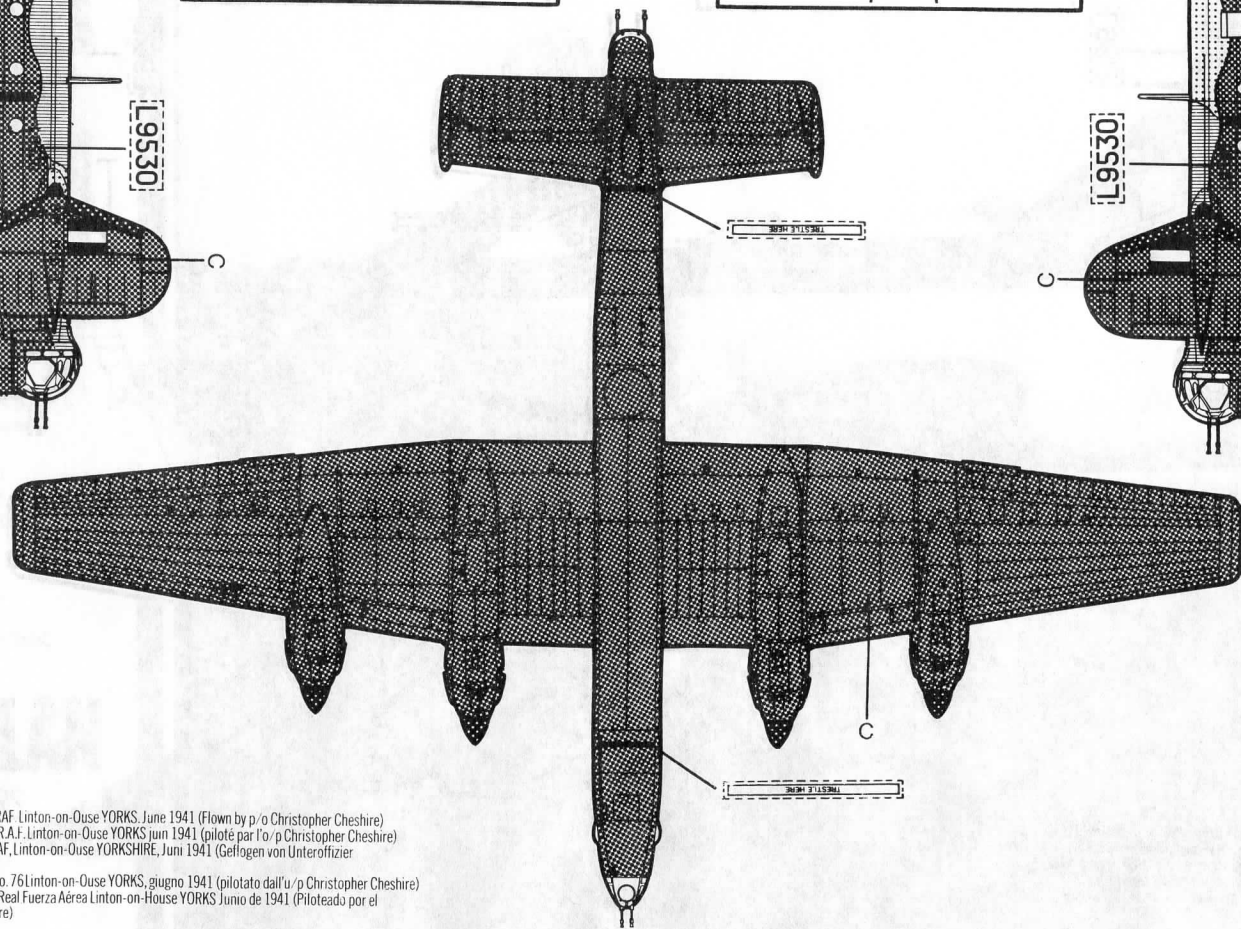
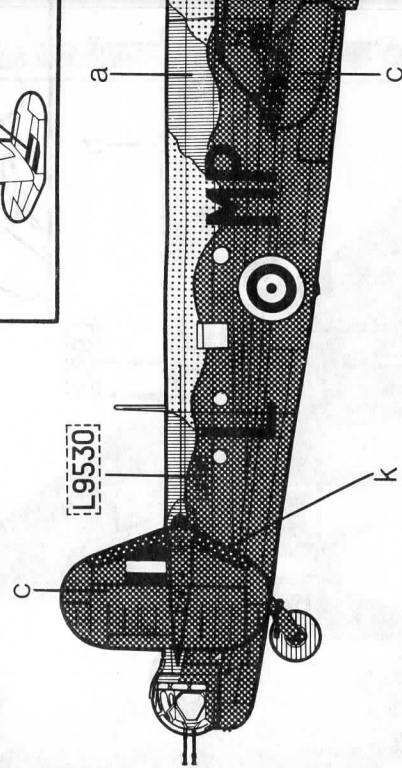
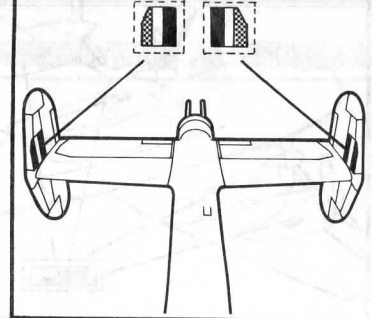
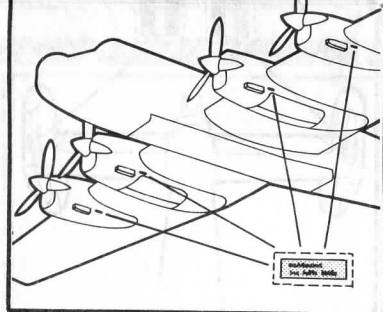
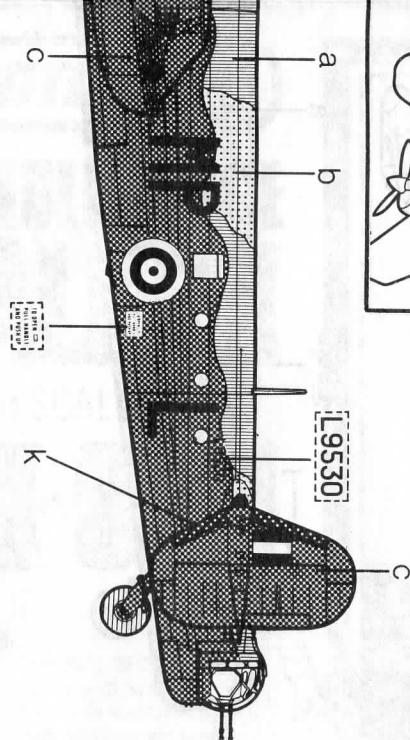

2

HALIFAX B1 No 76 Squadron RAF, Linton-on-Ouse YORKS, June 1941 (Flown by p/o Christopher Cheshire)
 HALIFAX B1 Escadrille No. 76 R.A.F. Linton-on-Ouse YORKS iun 1941 (pilote par l'o/p Christopher Cheshire)
 HALIFAX B1, 76. Schwadron RAF, Linton-on-Ouse YORKSHIRE, Juni 1941 (Geflogen von Unteroffizier Christopher Cheshire)
 HALIFAX B1 Squadriglia RAF No. 76 Linton-on-Ouse YORKS, giugno 1941 (pilotato dall'u/p Christopher Cheshire)
 HALIFAX B1 Escuadrón No 76 Real Fuerza Aérea Linton-on-House YORKS Junio de 1941 (Piloteado por el suboficial Christopher Cheshire)

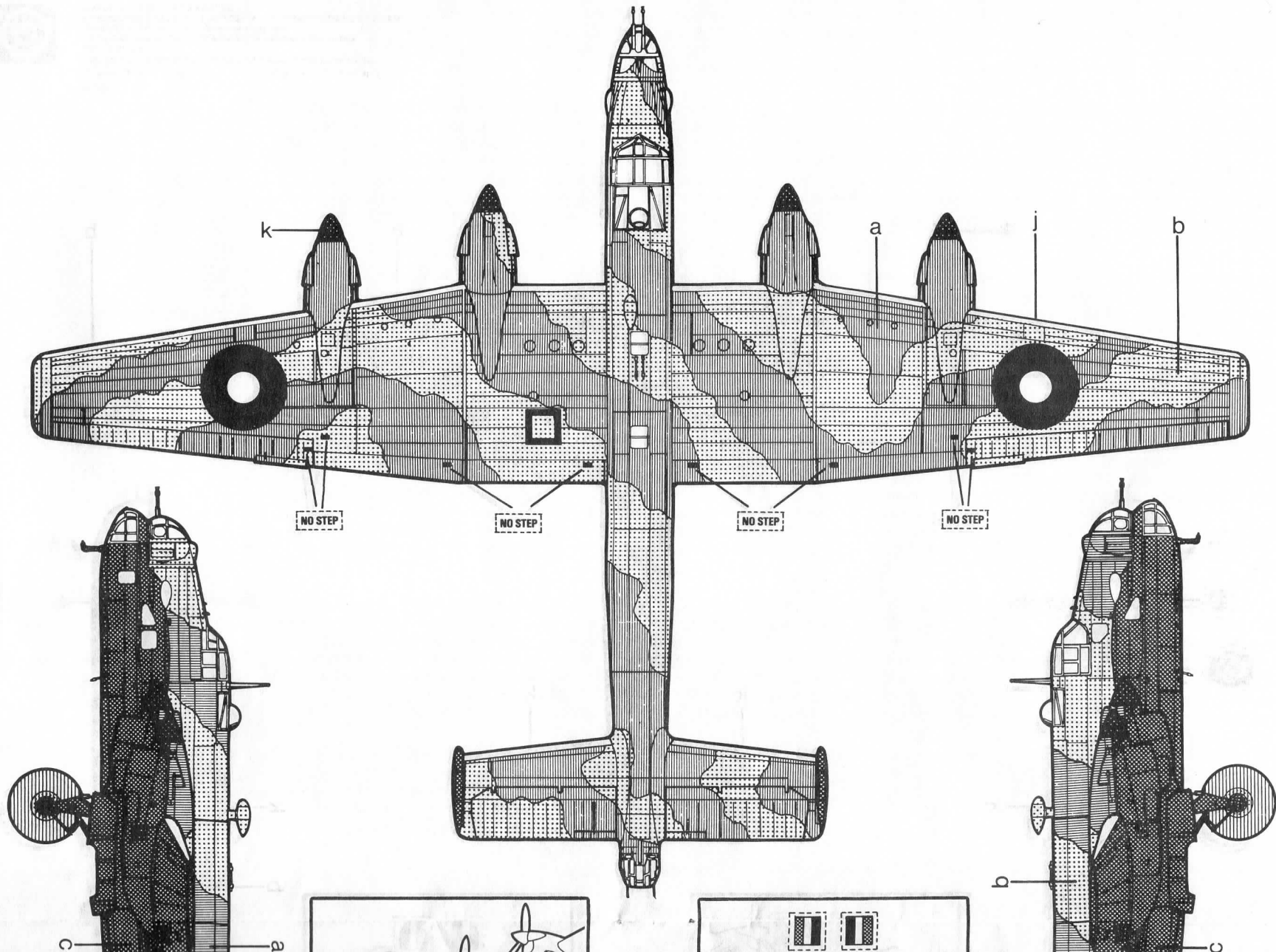

3

HALIFAX B 11 No 10 Squadron RAF Leeming YORKS, February 1942
HALIFAX B 11 Escadrille RAF No. 10 Leeming YORKS, février 1942
HALIFAX B 11 10. Schwadron, RAF Leeming YORKSHIRE, Februar 1942
HALIFAX B 11 Squadriglia No. 10 Leeming YORKS, febbraio 1942
HALIFAX B 11 Escuadrón No 10 de la Real Fuerza Aérea de Leeming
YORKS. Febrero de 1942

