

## **Sea Harrier FA.2 “Hi-Tech”**

### **CZ - Historie**

Stíhací verze BAE FA.2 Sea Harrier, která byla ve výzbroji britského Royal Navy a stále zůstává ve výzbroji indického námořnictva, je modifikovanou a vylepšenou verzí Sea Harrieru FRS 1. Ten byl užíván jako stíhačka, průzkumný a útočný stroj. Původní označení FRS 2 bylo změněno na FA. 2, které více napovídá o jeho primárním určení. Byl navržen pro stíhací a bitevní akce ale hlavně poskytoval vzdušné krytí flotily letadlových lodí, převážně proti nízko létajícím útočným letounům vyzbrojeným protilodními střelami s dlouhým doletem. Sea Harrier FA.2 poprvé vzlétl v roce 1988 a do služby byl zaveden v roce 1993. Pro Royal Navy bylo vyrobeno 56 strojů převážně konverzí z verze FRS 1. Sea Harriery FA.2 byly vyřazeny ze služby v březnu 2006. Sea Harrier je poháněn jedním proudovým motorem Rolls-Royce Pegasus Mk. 104 nebo Mk. 106. Do jeho výzbroje patří střely středního doletu Raytheon AIM-120A AMRAAM vybavené aktivním vyhledávacím radarem s dosahem přes 50 mil. Dále střely vzduch - vzduch AIM-9 M/L Sidewinder, umožňují Harrieru bojovat s letouny v klasickém vzdušném souboji na krátkou vzdálenost. První ze tří squadron Royal Navy vybavená Sea Harriery byla vyřazena ze služby v březnu 2004. Poslední, 801 NAS squadrona byla vyřazena ze služby 29. března 2006.

Technická data: Rozpětí: 7.6 m, délka: 14.2 m, max. rychlost: 1182 km/h, bojový radius: 1000 km  
dolet: 3,600 km, dostup: 16,000 m, stoupavost: 250 m/s

### **EN - History**

The BAE FA.2 Sea Harrier fighter aircraft, which was in service with the British Royal Navy and remains in service with the Indian Navy, is a modified and updated version of the Royal Navy's Sea Harrier FRS1 fighter, reconnaissance and strike aircraft. Originally designated the FRS 2 it was changed to FA 2 to more correctly denote the Fighter/Attack roles it was employed in as it provided air defense for the carrier fleet, particularly against low-flying attack aircraft armed with long-range air-to-surface missiles. The FA2 first flew in 1988 and entered service in 1993. 56 aircraft were built for the Royal Navy, many of which were conversions of FRS 1's. The Sea Harrier was retired from the Royal Navy in March 2006. It was powered by a single Rolls-Royce Pegasus Mk 104 or Mk 106 turbofan engine. The FA.2 was equipped with the Raytheon AIM-120A AMRAAM medium-range air-to-air missile, equipped with an active radar seeker and range of over 50 miles. The AIM-9 M/L Sidewinder air-to-air missile provided the Harrier with capability for firing close range at an approaching enemy aircraft in a dogfight. The first of the Royal Navy's three Sea Harrier squadrons was decommissioned in March 2004. The final Sea Harrier squadron, 801 NAS, was decommissioned on 29 March 2006.

Technical Data: Wingspan: 7.6 m, Length: 14.2 m, Maximum speed: 1182 km/h, Combat radius: 1000 km  
Ferry range: 3,600 km, Service ceiling: 16,000 m, Rate of climb: 250 m/s

**A** Plastic Parts

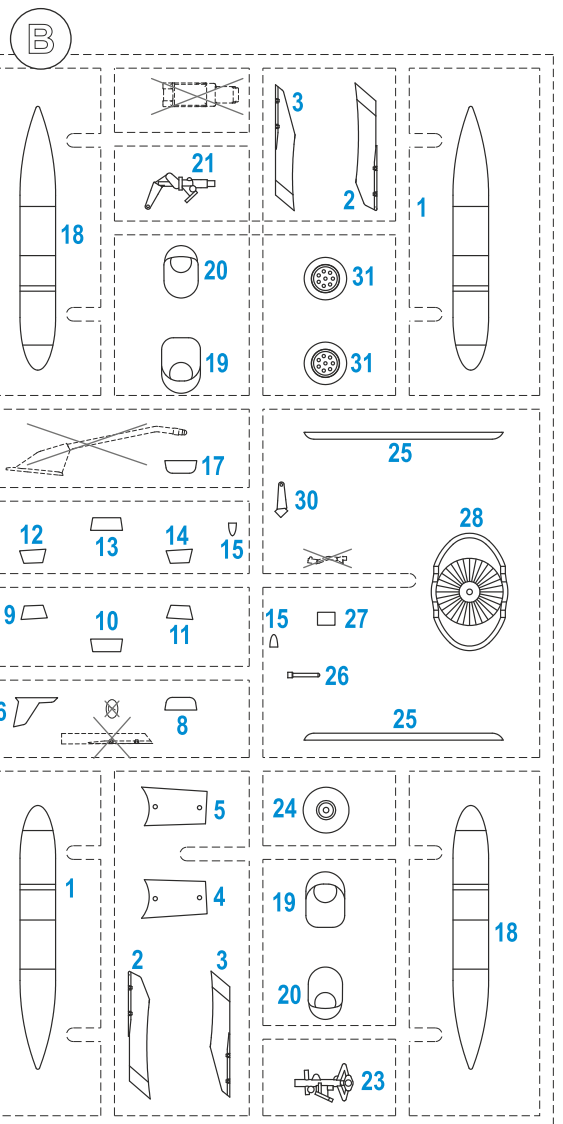
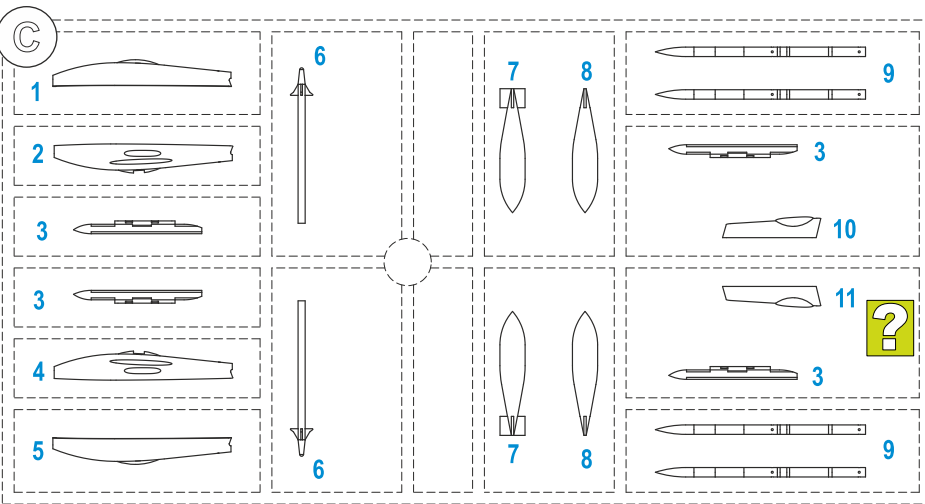
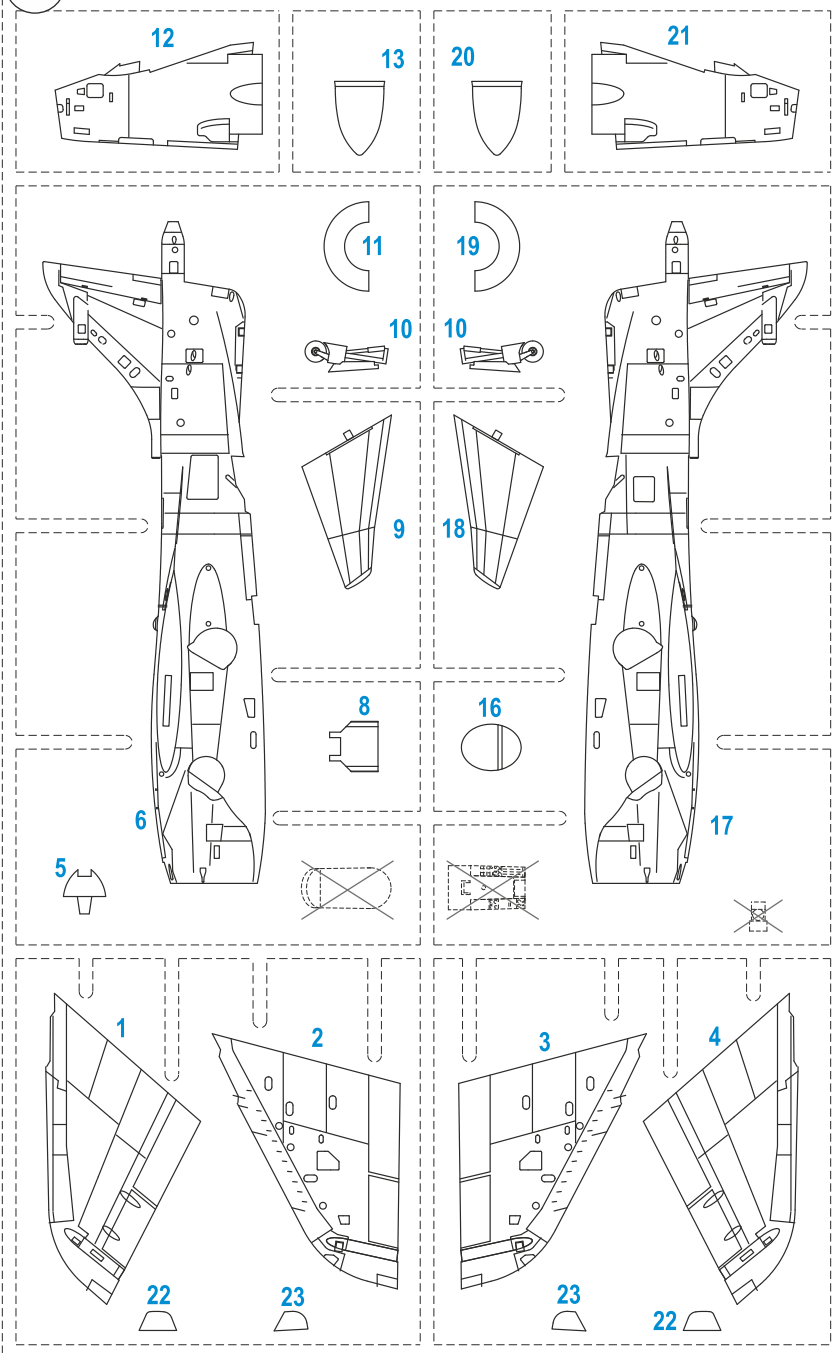

**CP** Clear Parts

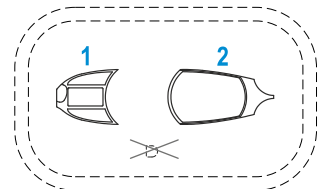

Resin Parts

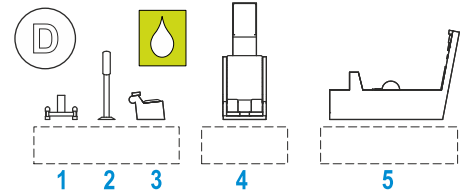
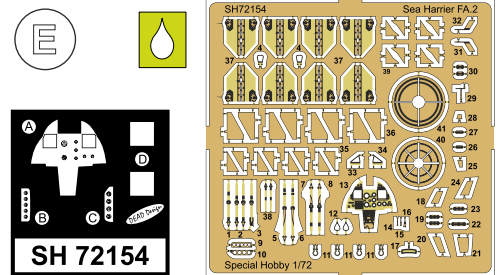

Photo-etched Parts



**SYMBOLS**

**?** MOŽNOST VOLBY  
OPTIONAL  
NACH BELIEBEN  
OPTION

**👉** POUŽÍT KYANOAKRYLÁTOVÉ LEPIDLO  
INSTANT CYANOACRYLATE GLUE  
ZYANOAKRYLÁTKLEBER  
ADHÉSIF CYANOACRYLAT

**↺↻** OHNOUT  
BEND  
BIEGEN  
COURBER

**👉** ZHOTOVIT NOVÉ  
SCRATCH BUILD  
FERTIGSTELLEN  
ACHEVER

**🔪** ŘEZAT/VRTAT  
CUT OFF/DRILL  
ENTFERNEN  
DETACHER

**A** NATRÍT  
COLOUR  
FARBEN  
PEINDRE  
GSI colours code

1

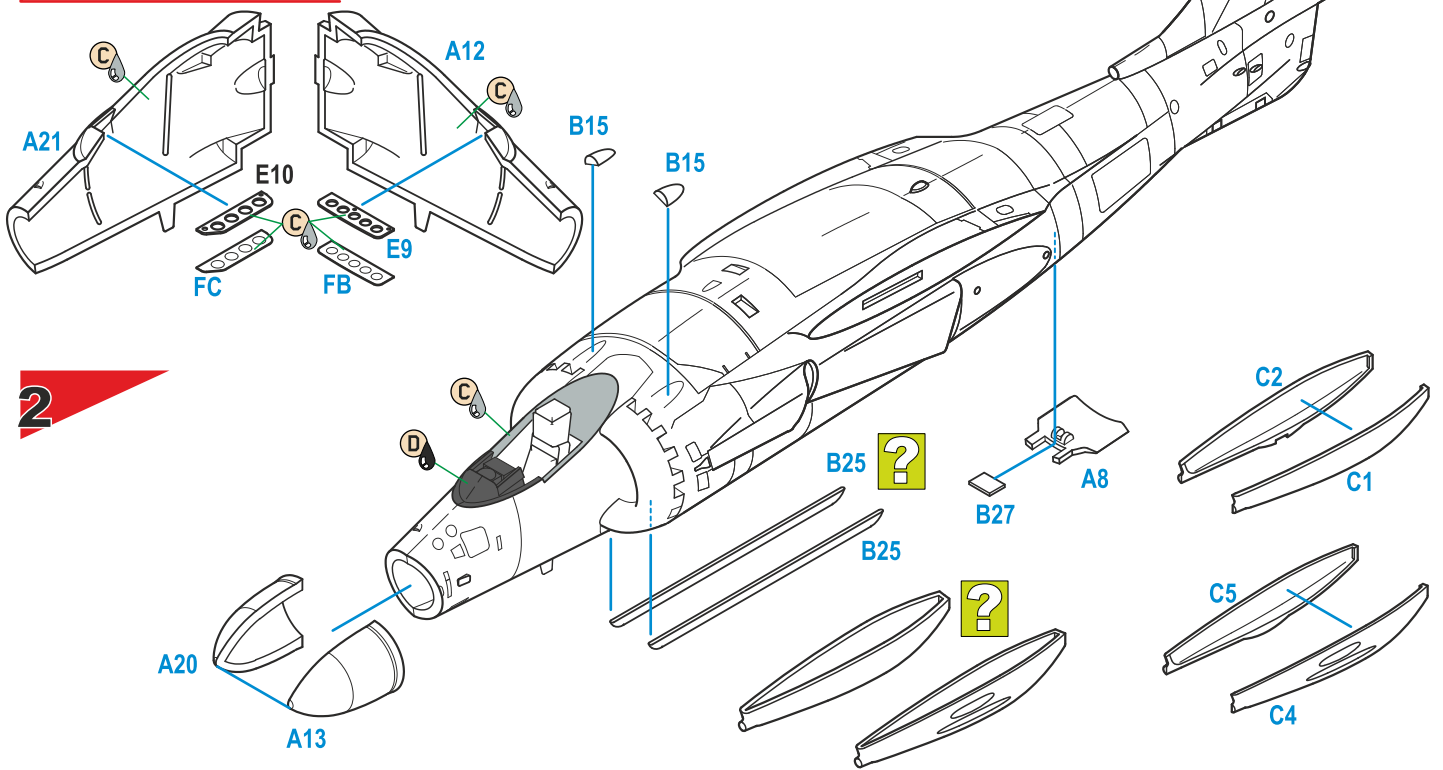
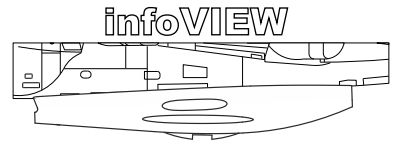
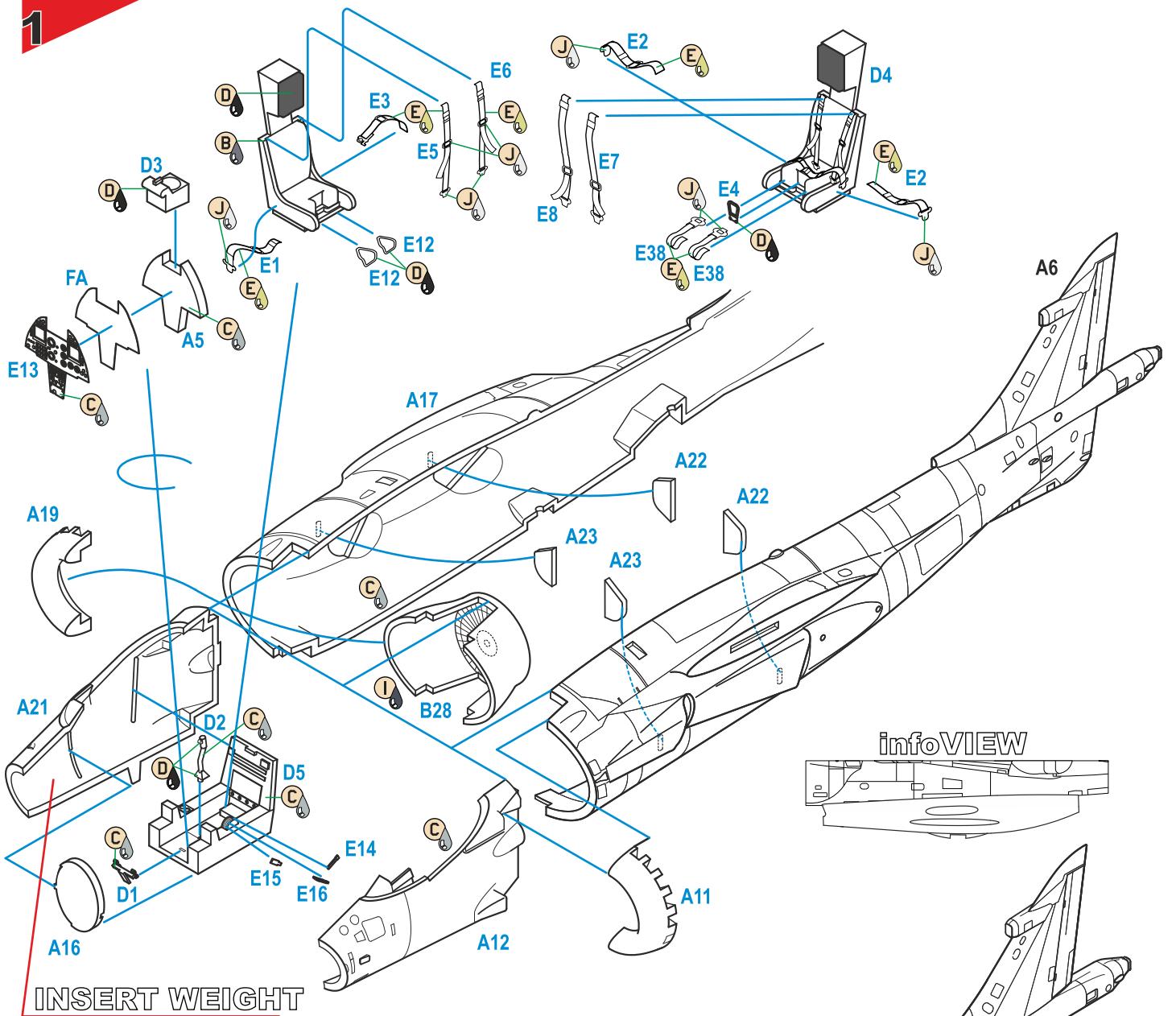

2

3

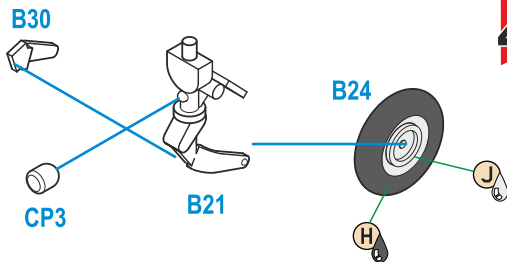

4

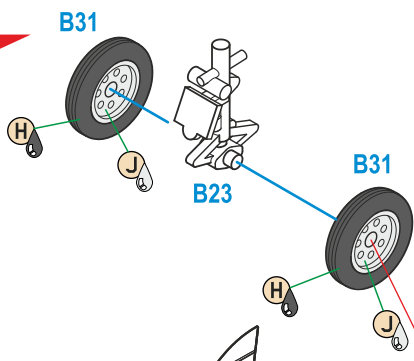

Diam. 1,5mm

5

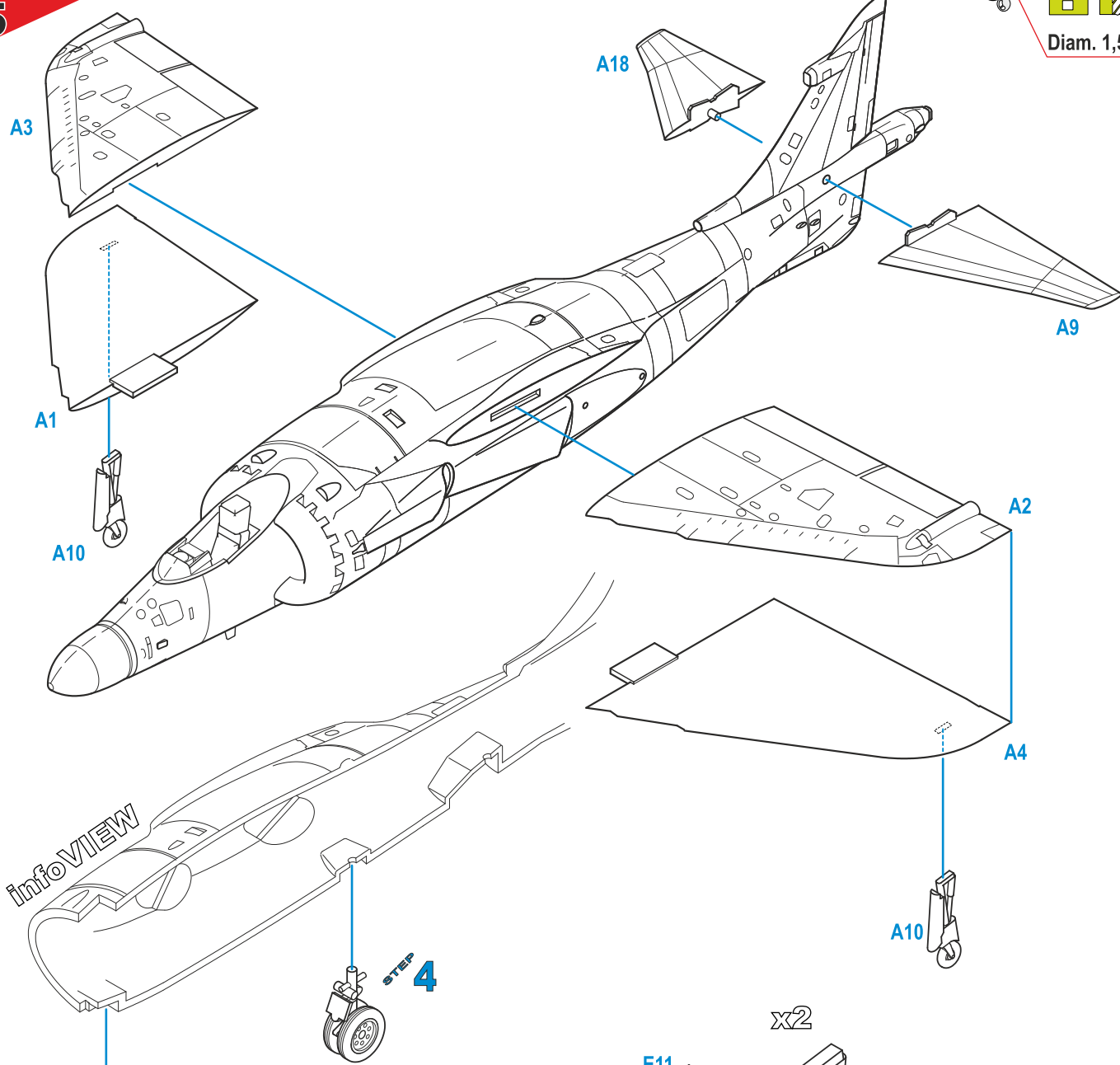

**Barvy GUNZE/ GUNZE Colour No.**

<b>A</b>	Bílá/ White	H1/C1
<b>B</b>	Tmavá mořská šedá/ Dark Sea Grey	C366
<b>C</b>	Sřřední mořská šedá/ Medium Sea Grey	C365
<b>D</b>	Černá/ Black	H12/C33
<b>E</b>	Žlutohnědý nylon/ Yellow-Brown Nylon	H71/C21
<b>F</b>	Barva trysek/ Exhaust	H329/C329
<b>H</b>	Černá na pneu/ Tire Black	H77/C137
<b>I</b>	Tmavý kov/ Dark Metal	MC214
<b>J</b>	Hliník/ Aluminium	H8/C8

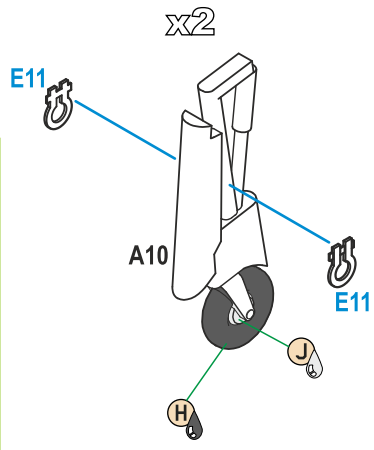

6

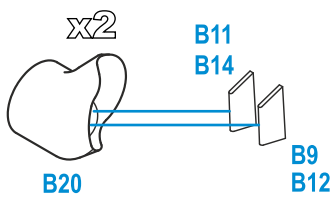

7

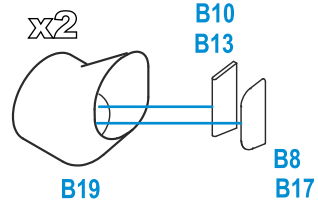

8

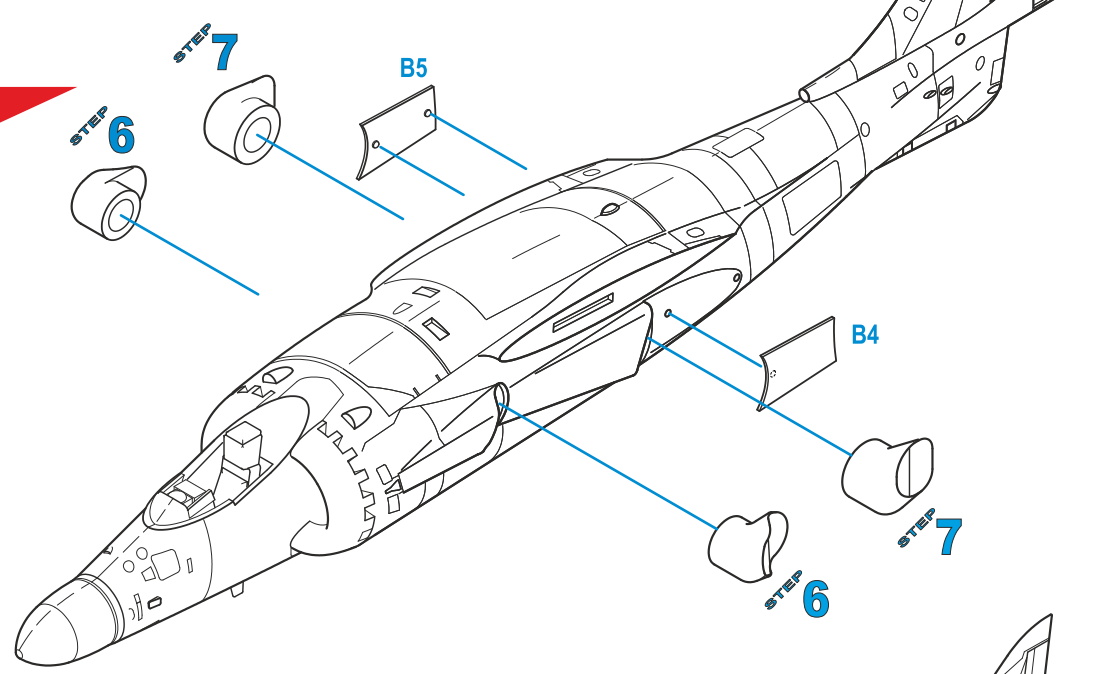

9

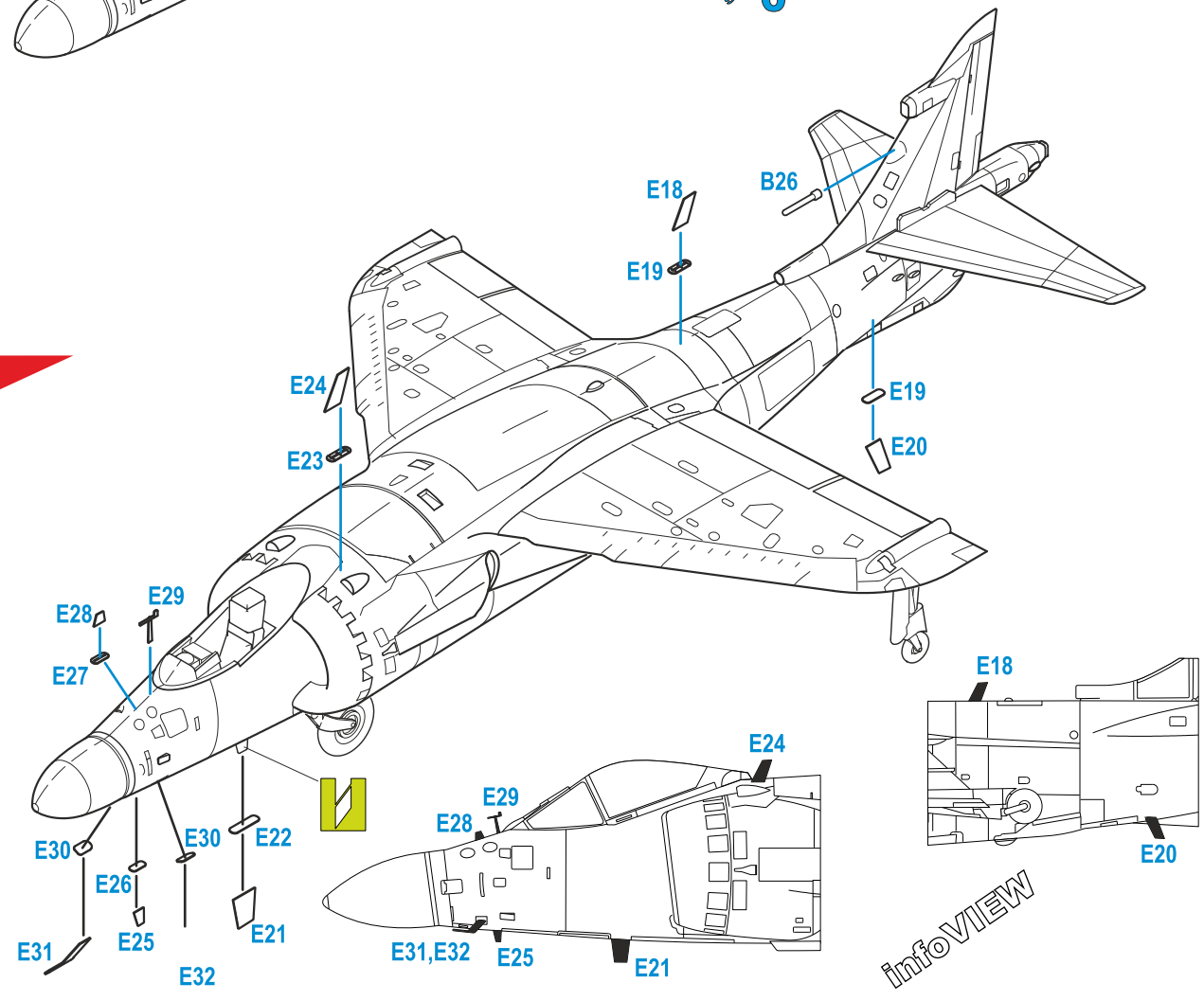

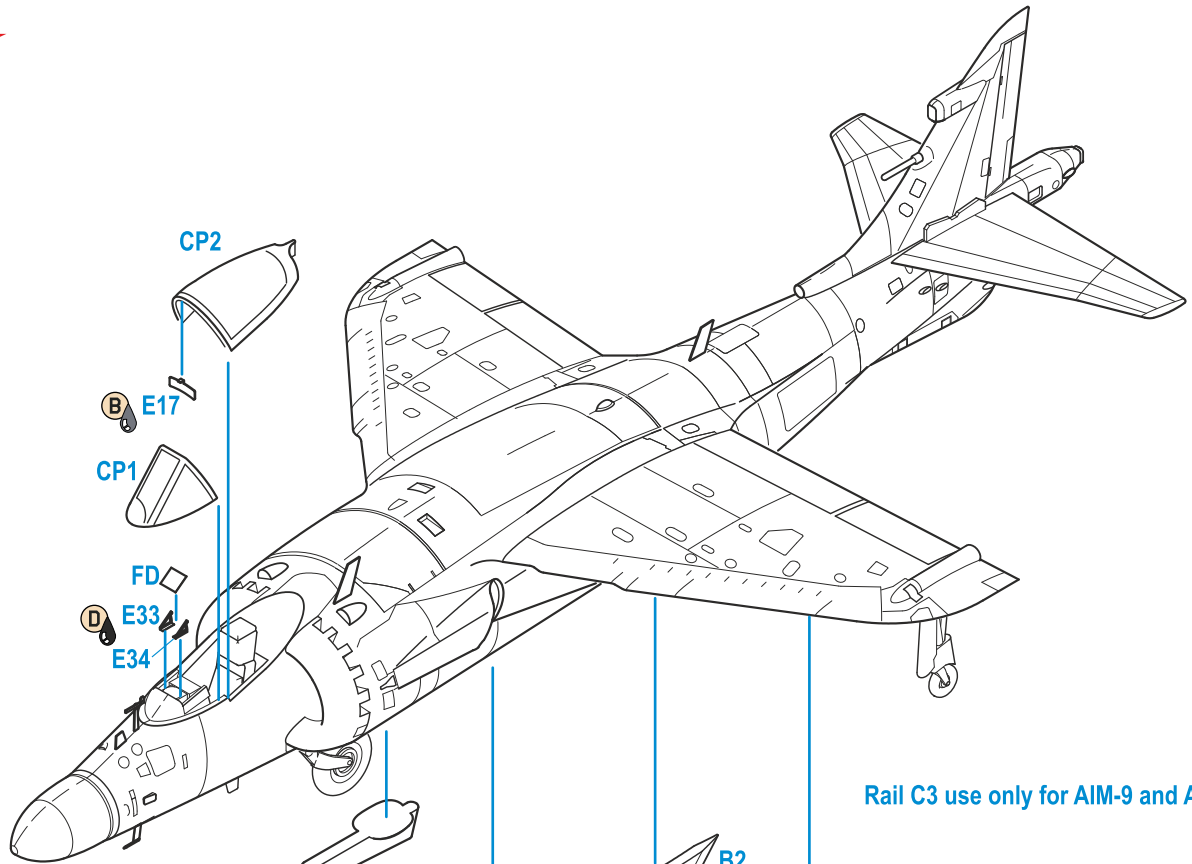

Rail C3 use only for AIM-9 and AIM-120

infoVIEW

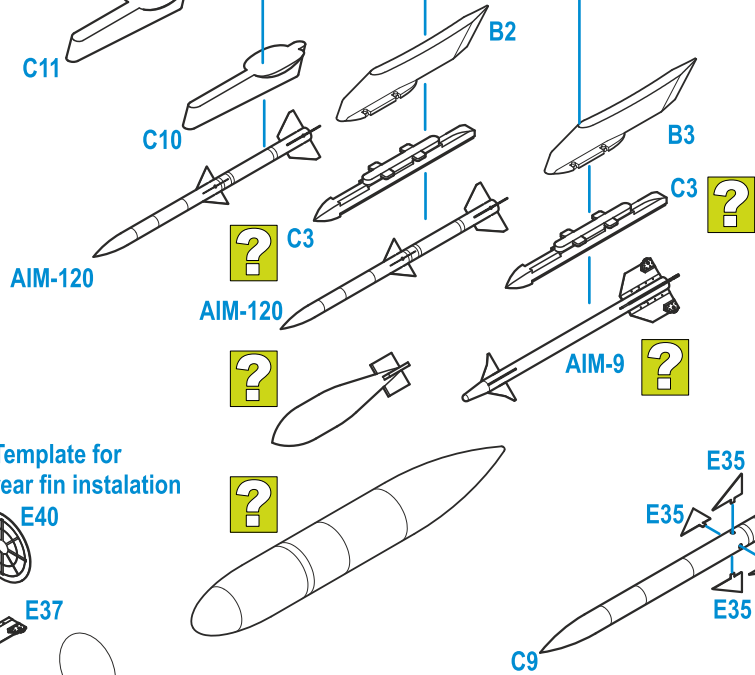
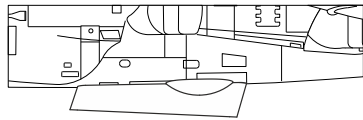

Template for wing installation



Template for rear fin installation

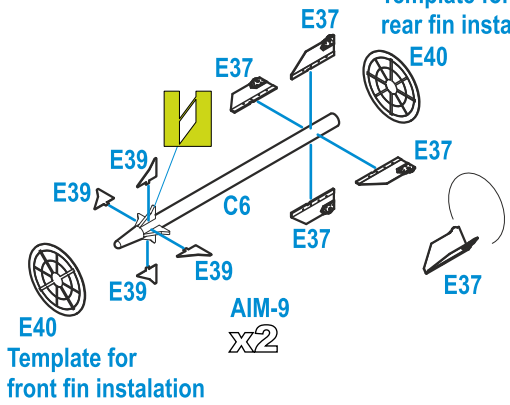

E40  
Template for front fin installation

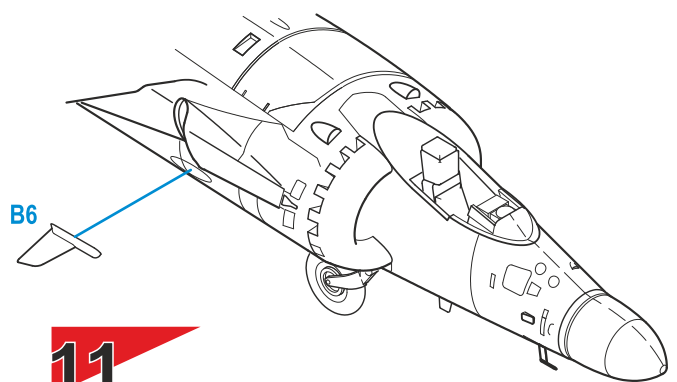
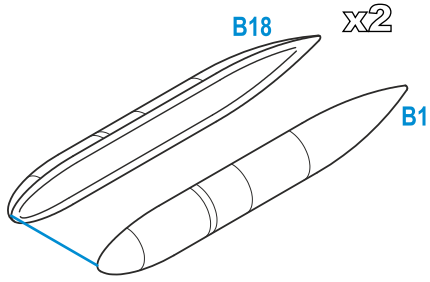

Sea Harrier FA.2, ZH809/710, 899 Naval Air Squadron, pilot Cdr. J. Lawley, 2004. Tento Sea Harrier FA.2 byl přestříkán do výročního markingu u příležitosti 25 výročí služby Sea Harrierů u FAA a Royal Navy. Marking připoměl první typ kamufláže Sea Harrierů u Royal Navy. Protože ale původní barva Extra Dark Sea Grey nebyla dostupná, byla použita na horní plochy barva Roundel Blue. Nápis Fly Navy se na letounu objevil až ke konci roku 2004.

Sea Harrier FA.2, ZH809/710, 899 Naval Air Squadron, pilot Cdr. J. Lawley, 2004. This Sea Harrier FA. 2 sported color scheme and markings for 25th anniversary of FAA and Royal Navy Sea Harriers' service. The color scheme commemorates the first camouflages used on Royal Navy Sea Harriers. Since the original Extra Dark Sea Grey color was not available any more the upper surfaces were sprayed by Roundel Blue color. The Fly Navy legend appeared on the lower sides of the wings not until end of 2004.

CAM. A

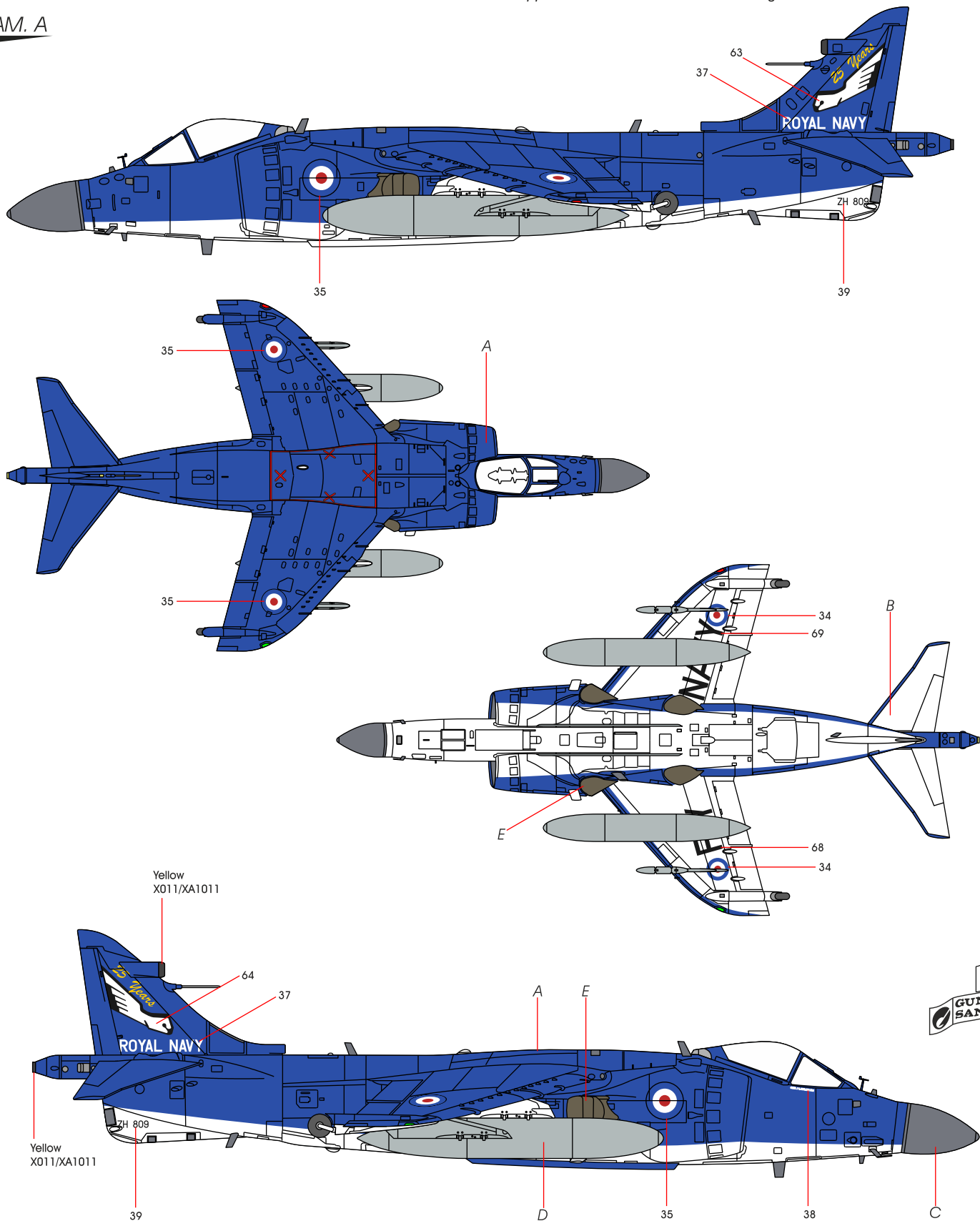

- A**



Modrá  
Insignia Blue  
C365
- B**



Bílá  
Insignia White  
H21 / C69
- C**



Tmavá mořská šedá  
Dark Sea Grey  
C366
- D**



Střední mořská šedá  
Medium Sea Grey  
C365
- E**



Barva trysek  
Exhaust  
H329/ C329

**CAM. B**

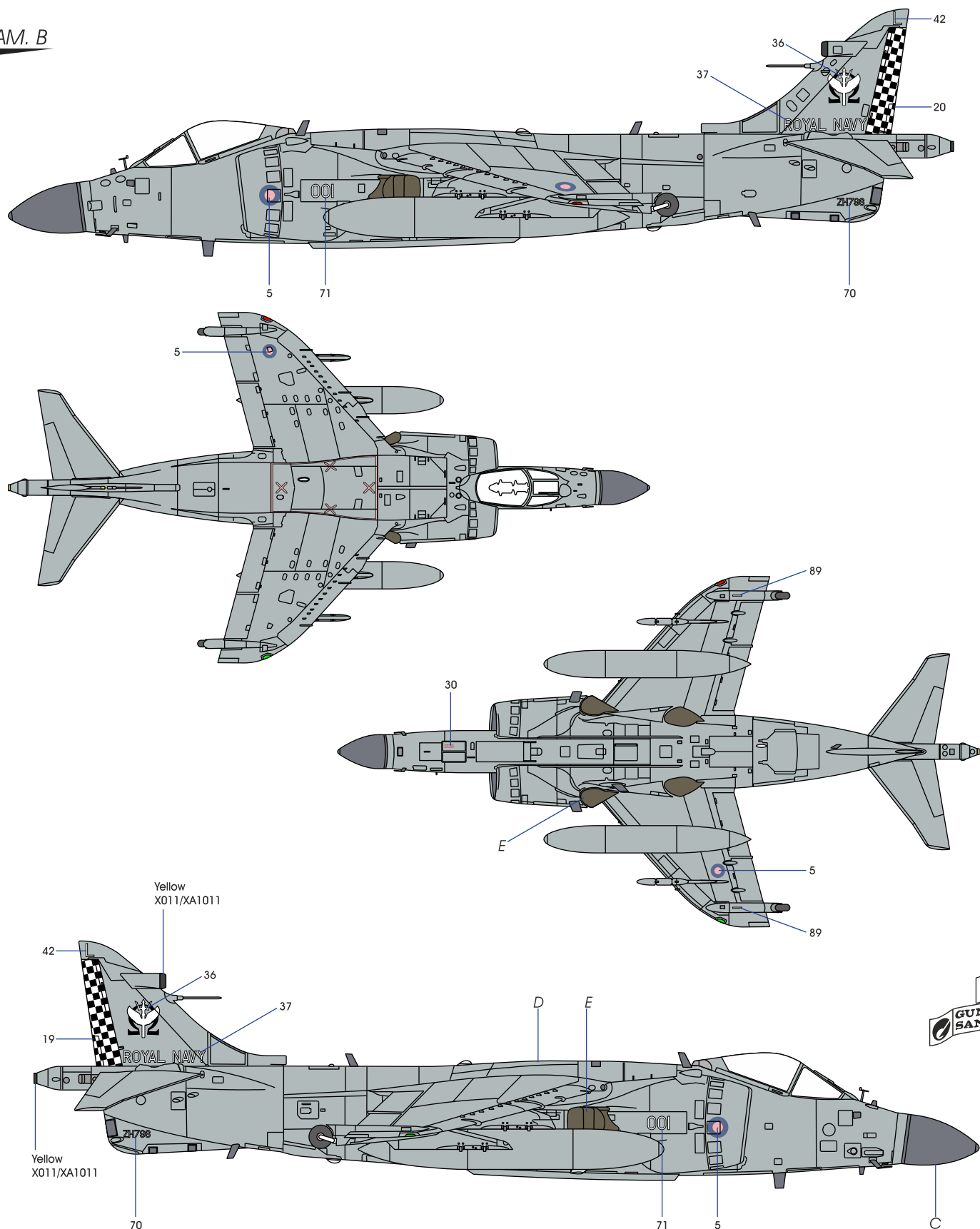

- |  |  |   |  |  |
|--|--|---|--|--|
| <p><b>A</b></p>  <p>Modrá<br/>Insignia Blue<br/>C365</p> | <p><b>B</b></p>  <p>Bílá<br/>Insignia White<br/>H21 / C69</p> | <p><b>C</b></p>  <p>Tmavá mořská šedá<br/>Dark Sea Grey<br/>C366</p> | <p><b>D</b></p>  <p>Střední mořská šedá<br/>Medium Sea Grey<br/>C365</p> | <p><b>E</b></p>  <p>Barva trysek<br/>Exhaust<br/>H329/ C329</p> |
|--|--|---|--|--|



Sea Harrier FA.2, ZD608/717, 899 Naval Air Squadron, RNAS Yeovilton, 2004. Stroj nese pod kabinou na levé straně symbol rakety a znak jednotky na svislé ocasní ploše na téže straně je neúplný.

Sea Harrier FA.2, ZD608/717, 899 Naval Air Squadron, RNAS Yeovilton, 2004. The aircraft sports a missile symbol on the port side below the canopy and also the squadron marking on the fin is incomplete.

CAM. C

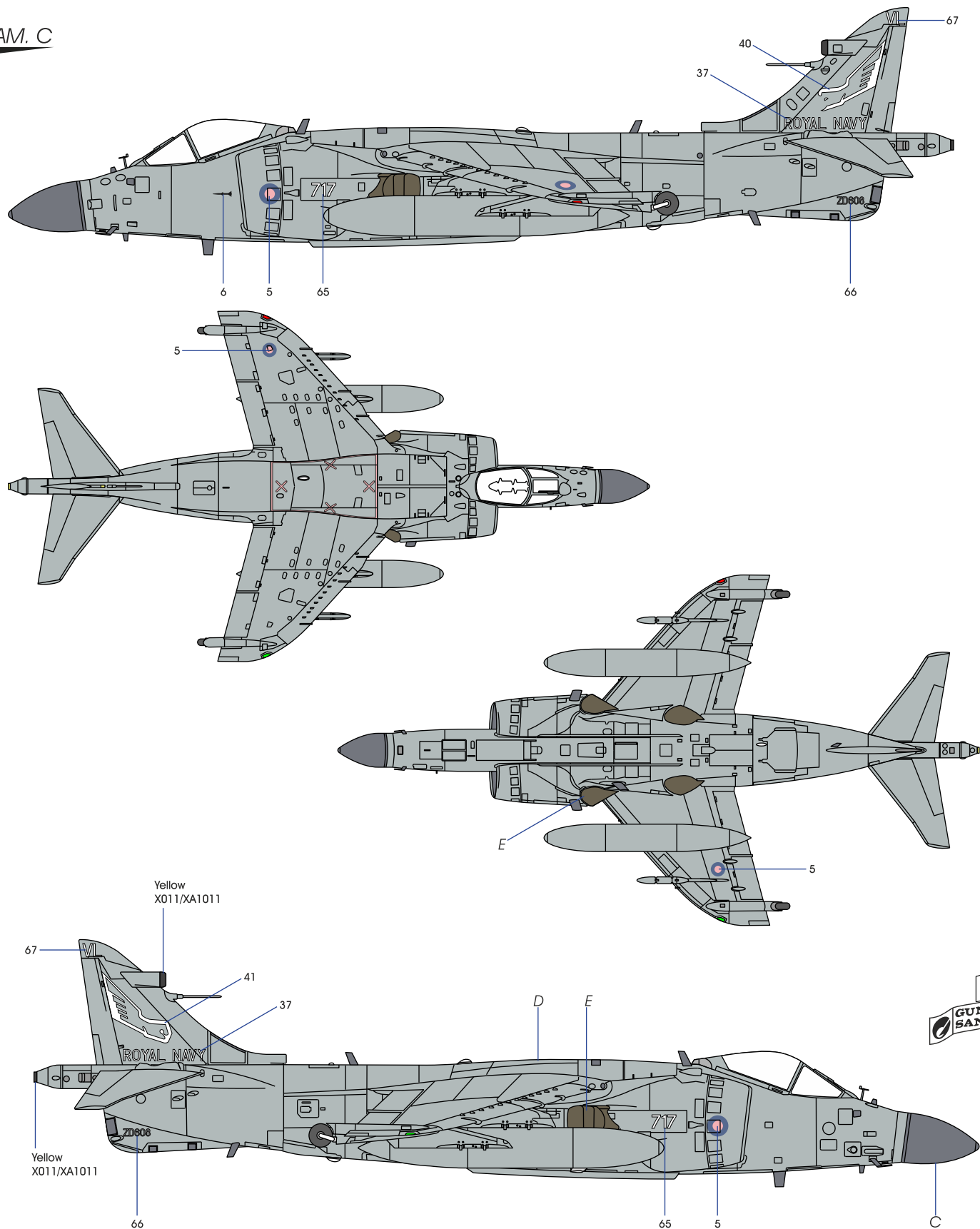

- A** Modrá  
Insignia Blue  
C365
- B** Bílá  
Insignia White  
H21 / C69
- C** Tmavá mořská šedá  
Dark Sea Grey  
C366
- D** Střední mořská šedá  
Medium Sea Grey  
C365
- E** Barva trysek  
Exhaust  
H329/ C329

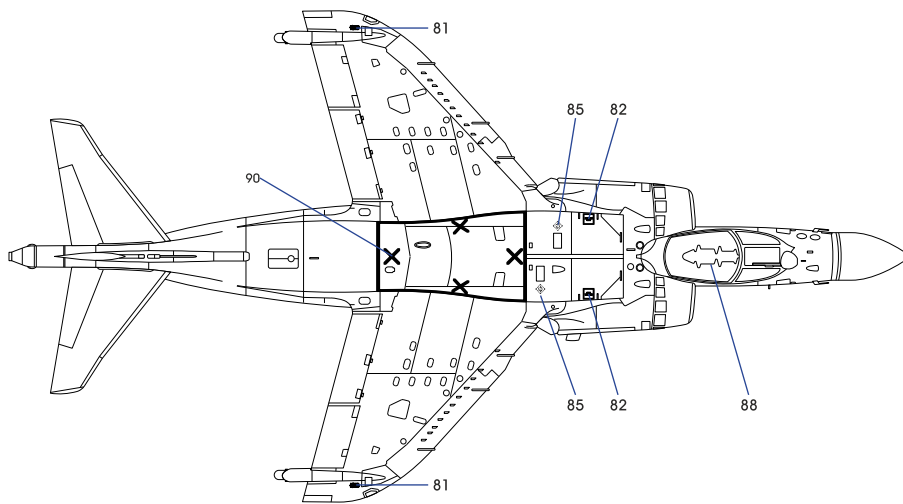
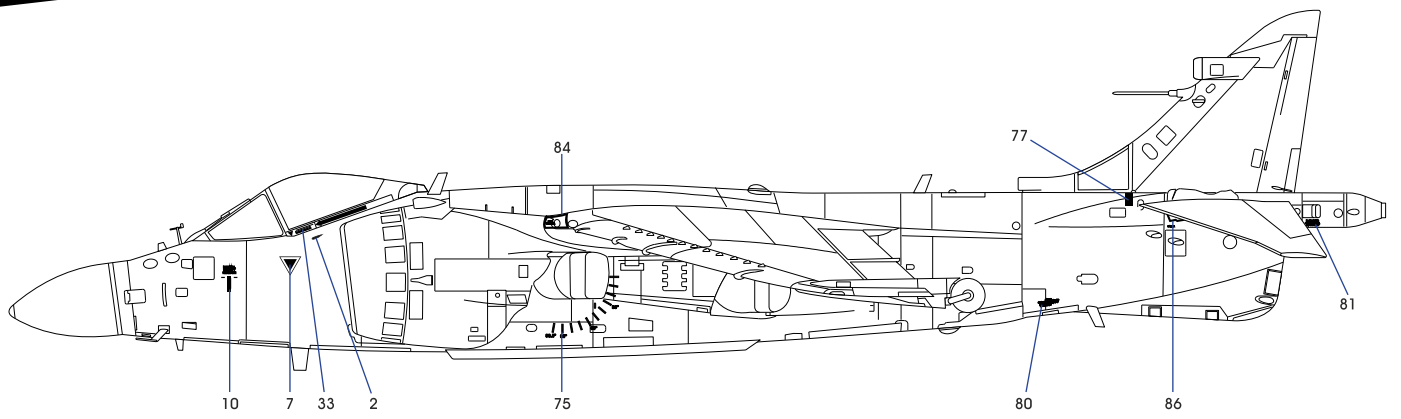

Outer pylon port

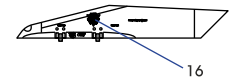

Outer pylon starboard

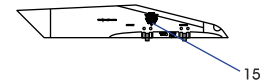

Top

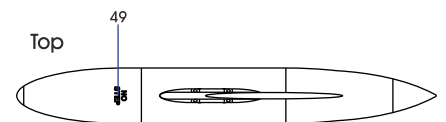

Inner Pylon Port

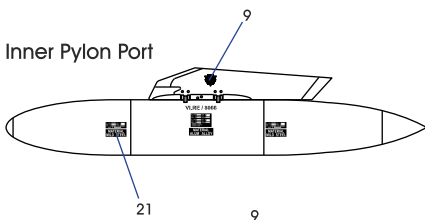

Inner Pylon Starboard

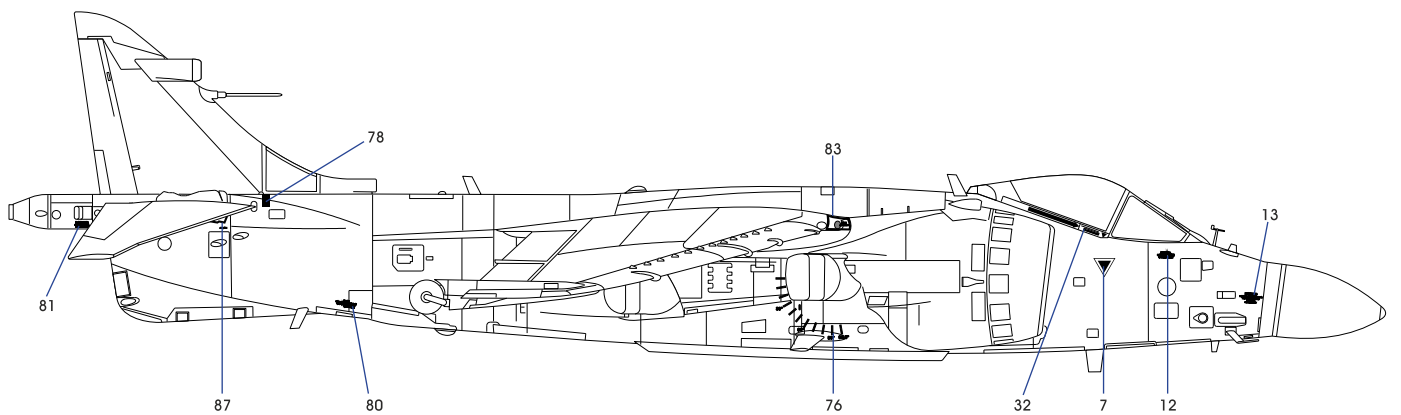
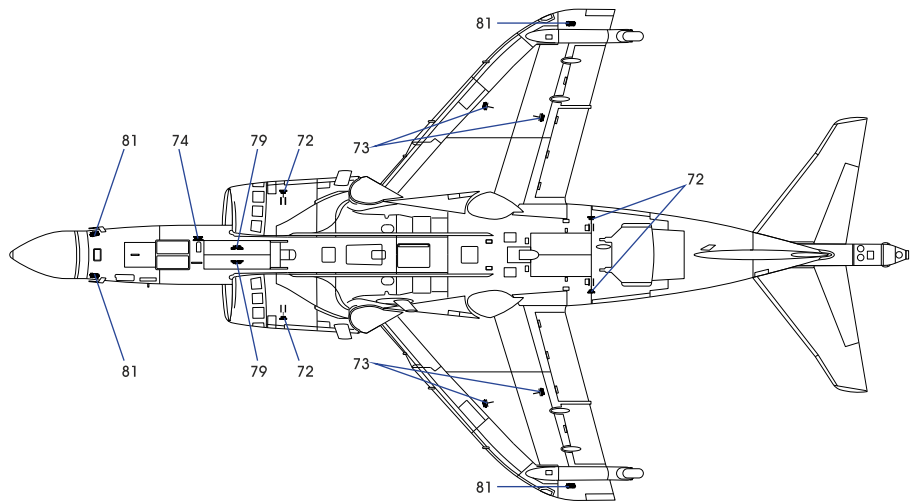
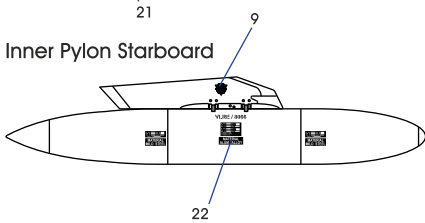

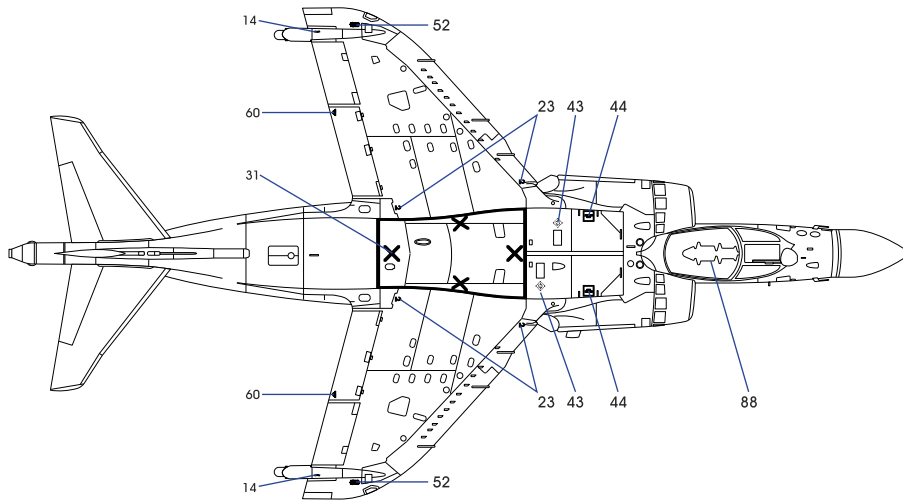
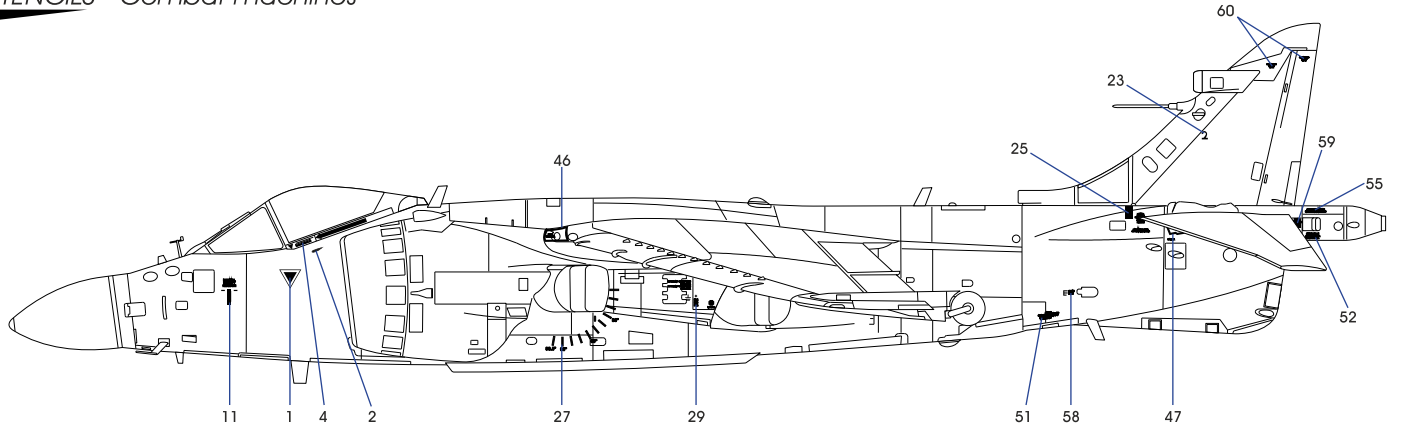

Outer pylon port

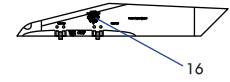

Outer pylon starboard

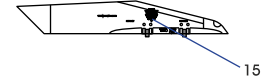

Top



Inner Pylon Port

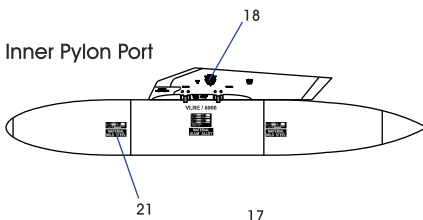

Inner Pylon Starboard

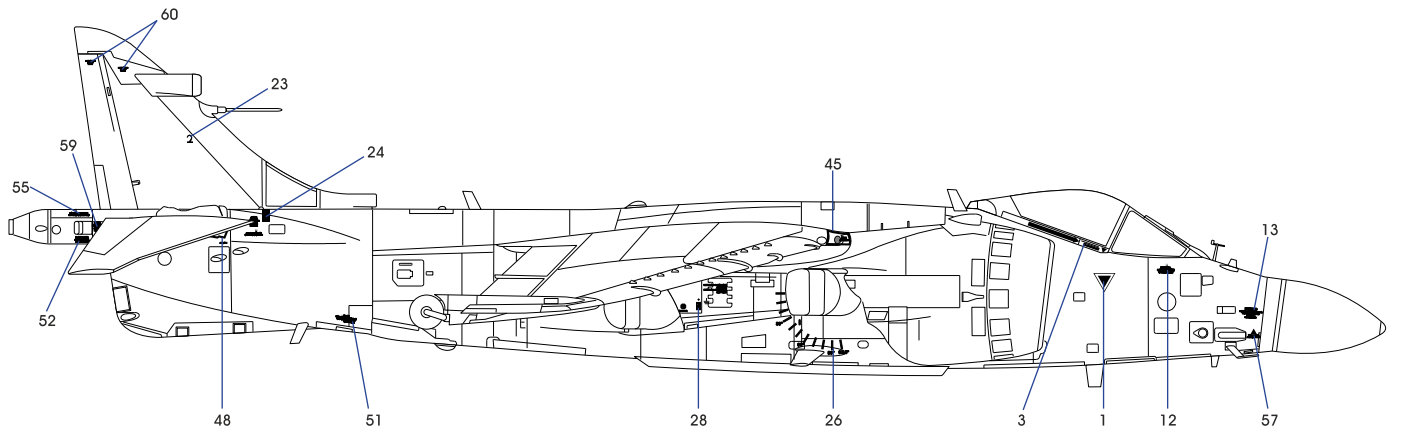
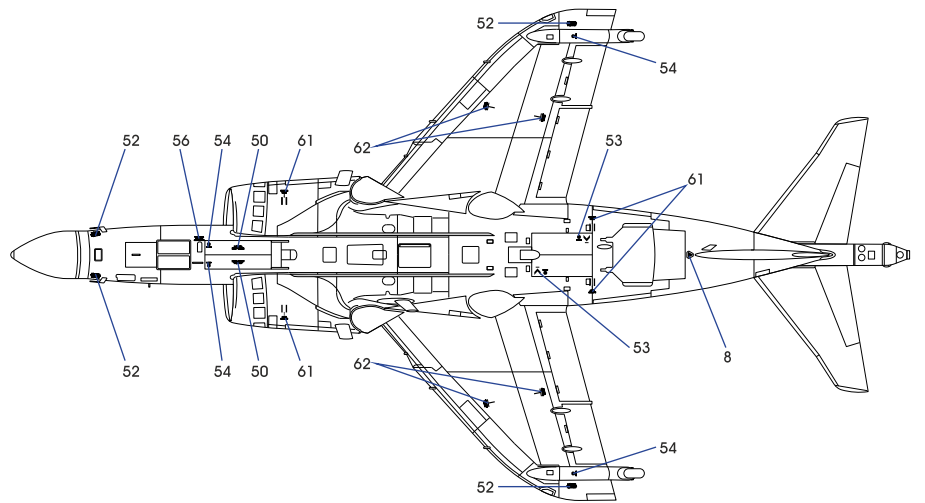
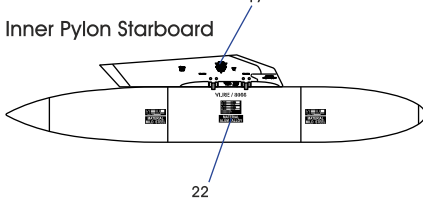



**USE CMK TOOLS AND WEATHERING PIGMENTS FOR YOUR KITS.**



ALL OF THE ABOVE ITEMS CAN BE FOUND AND ORDERED VIA OUR OFFICIAL WEBSITE AND E-SHOP.....

**WWW.SPECIALHOBBY.EU**  
**WWW.CMKKITS.COM**