

Bf.109F/G/K insignia and stencils

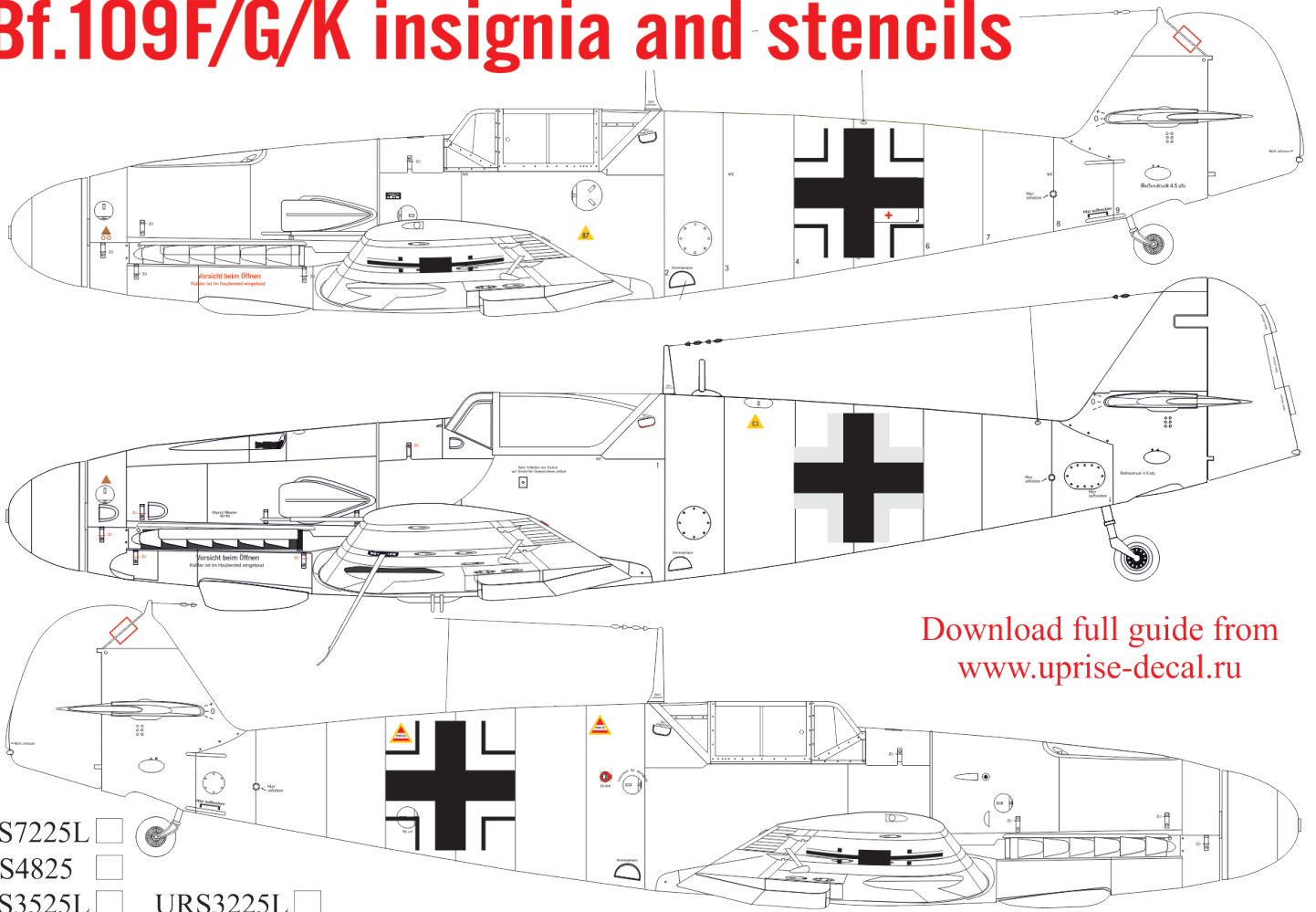

Download full guide from
www.uprise-decal.ru

- URS7225L
 URS4825
 URS3525L URS3225L

More Bf.109 from www.uprise-decal.ru

BF.109G-5/6/6Trop "Gustav"

A Bf.109G-5, WNr. 27119, 9/JG54, Spring 1944, Ludwigslust (Germany), pilot Gerhard Kroll, crashed 8 April 1944

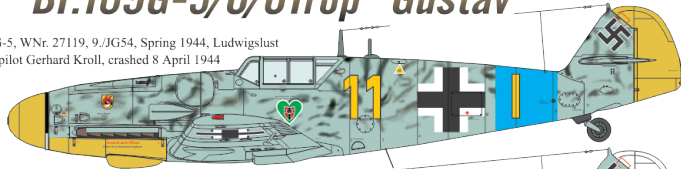

B Bf.109G-5, WNr. 27112, 3/JG54, December 1943, Russia, pilot Walther Dahl

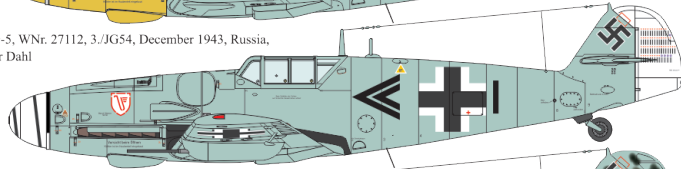

C Bf.109G-6, 7/JG53, January 1943, Italy (Sicily), pilot unknown

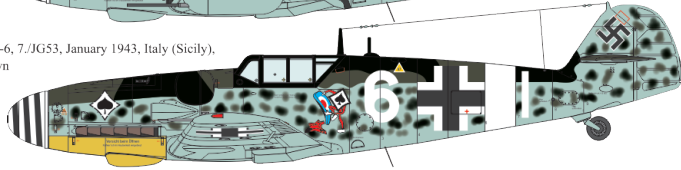

- URS7215L URS4815L URS3215L URS3515L

Download full guide from www.uprise-decal.ru
 Загрузите инструкцию с сайта www.uprise-decal.ru

BF.109F-2/4/4Trop "Friedrich"

A Bf.109F-4 Trop, WNr. 8673, 3/JG27, September 1942, Egypt, pilot Hans-Joachim Marcellie.



B Bf.109F-4, WNr. 7183, III/JG2, October 1941, France, pilot Hans "Assi" Hahn.

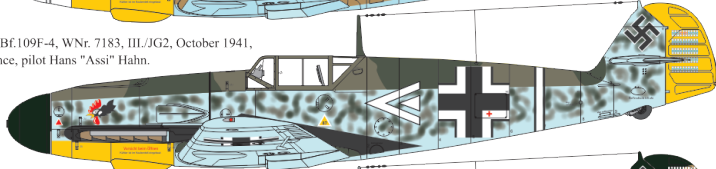

C Bf.109F-4, WNr. 13325, 9/JG3, June 1942, Poland (USSR?), pilot Viktor Bauer.

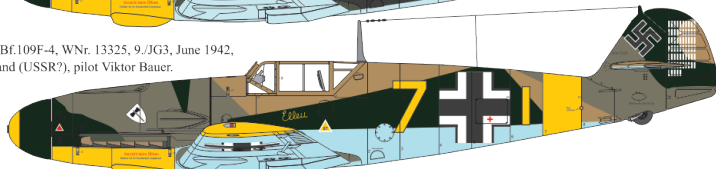

- URS7219L URS4819 URS3219L URS3519L

Download full guide from www.uprise-decal.ru
 Загрузите инструкцию с сайта www.uprise-decal.ru

D Bf.109G-6, WNr.18107, 7/JG53, May 1943, Italy (Sicily), pilot Georg Amon

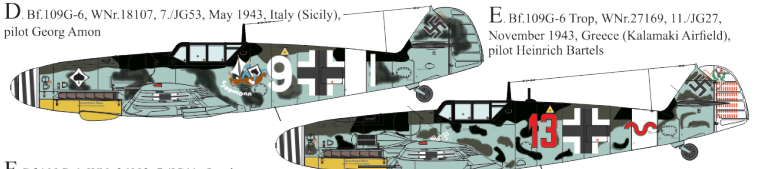

E Bf.109G-6 Trop, WNr.27169, 11/JG27, November 1943, Greece (Kalamaki Airfield), pilot Heinrich Bartels



F Bf.109G-6, WNr.26082, 7/JG11, October 1943, Germany (Oldenburg), pilot Victor Wildmayer

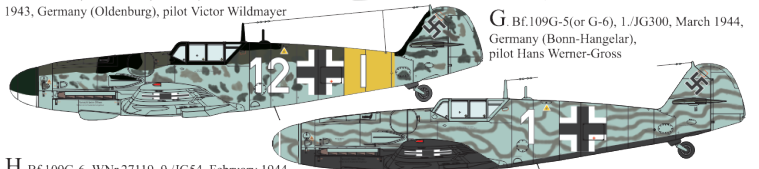

G Bf.109G-5(or G-6), 1/JG300, March 1944, Germany (Bonn-Hangelar), pilot Hans Werner-Gross

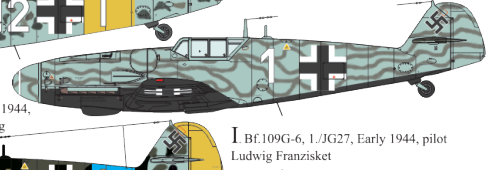

H Bf.109G-6, WNr.27119, 9/JG54, February 1944, Germany (Ludwigslust), pilot Wilhelm Schilling

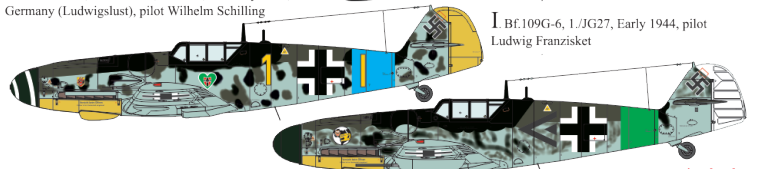

I Bf.109G-6, 1/JG27, Early 1944, pilot Ludwig Franzisket

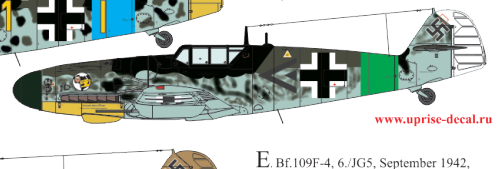

www.uprise-decal.ru

D Bf.109F-4 Trop, WNr. 7420, 9/JG27, November 1942, Egypt, pilot Andreas Kuhn.

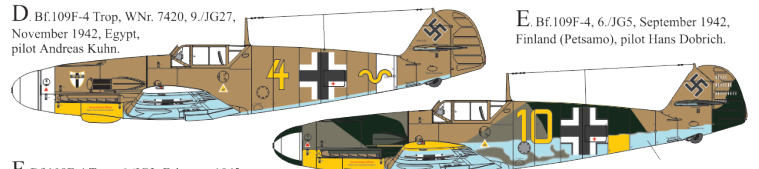

E Bf.109F-4, 6/JG5, September 1942, Finland (Petsamo), pilot Hans Dobrich.

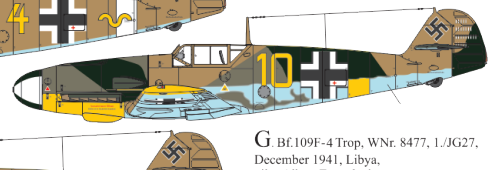

F Bf.109F-4 Trop, 6/JG3, February 1942, Italy, pilot Franz Schweiger.

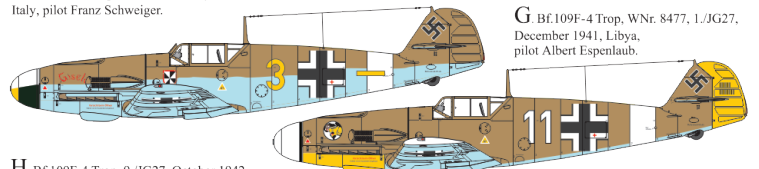

G Bf.109F-4 Trop, WNr. 8477, 1/JG27, December 1941, Libya, pilot Albert Espenlaub.

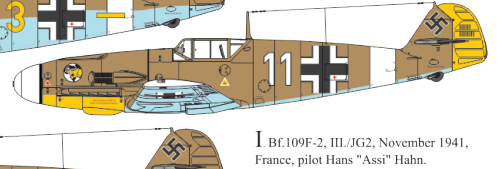

H Bf.109F-4 Trop, 9/JG27, October 1942, Egypt, pilot Helmuth Fenzi.

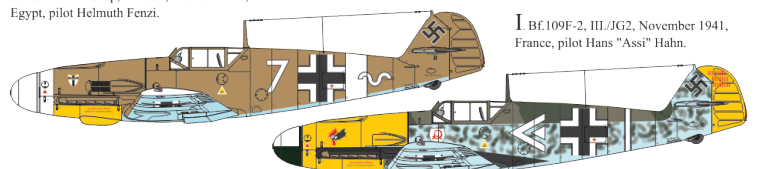

I Bf.109F-2, III/JG2, November 1941, France, pilot Hans "Assi" Hahn.

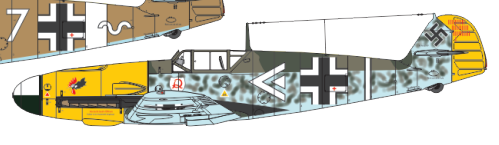

Bf.109F

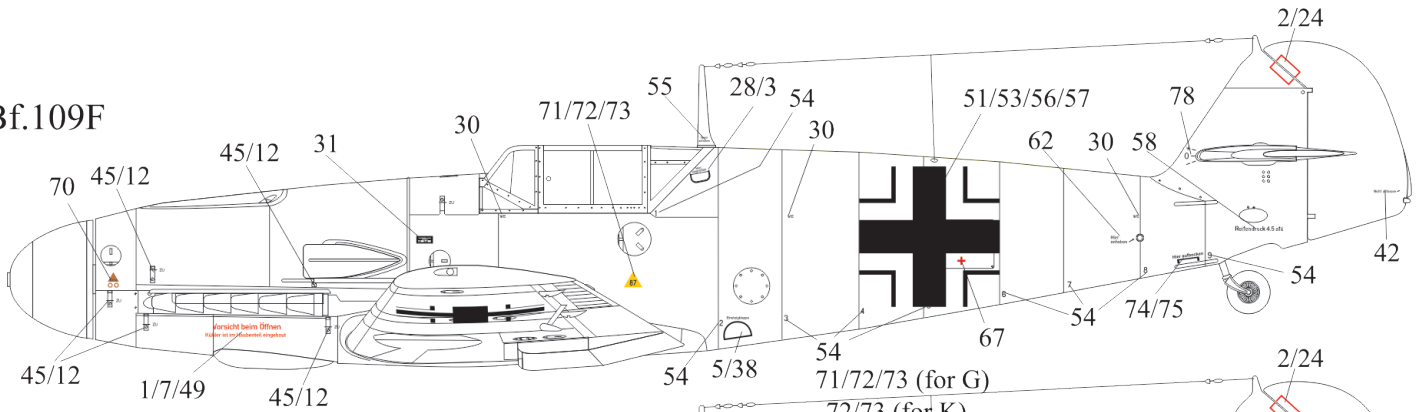

Bf.109G/K

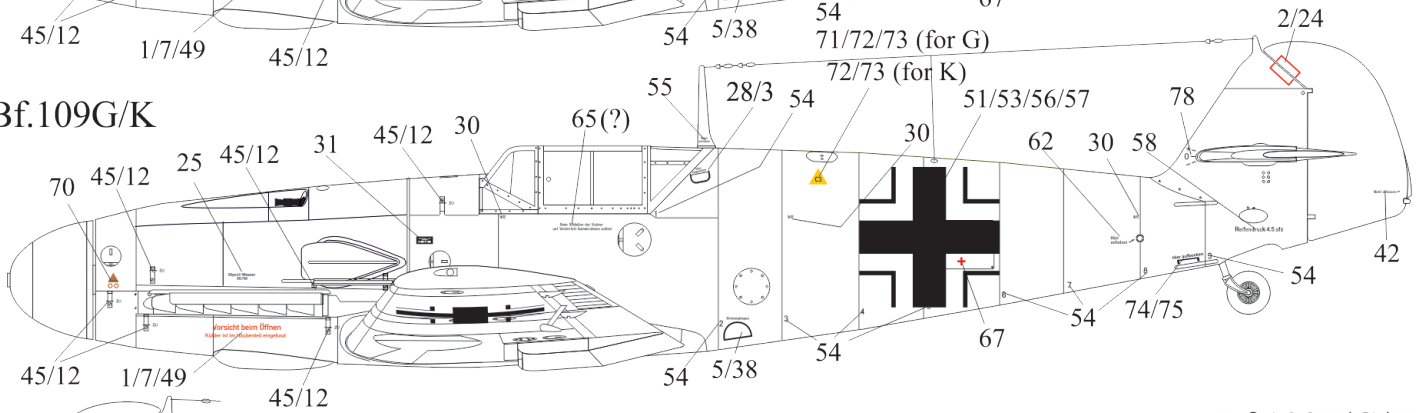

*- use your references **Bf.109F/G/K**

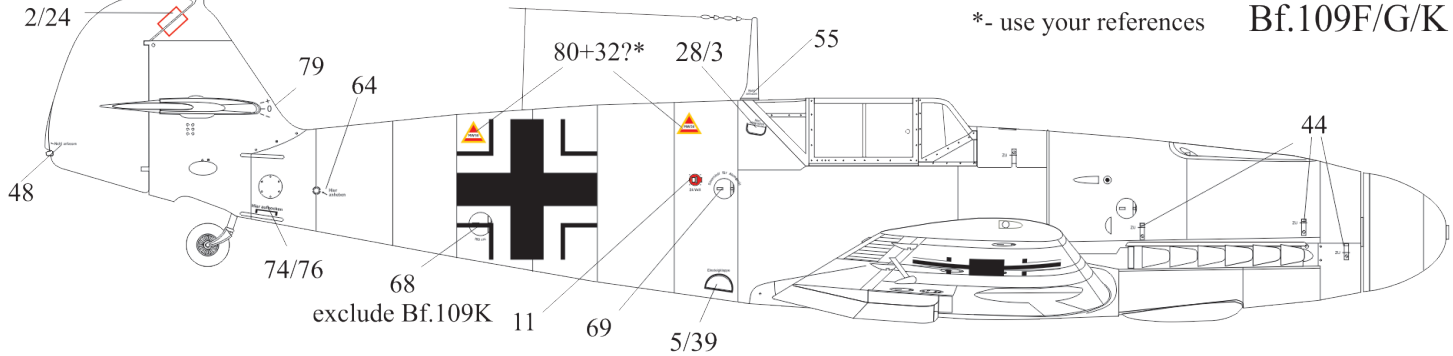

50 or 50+10 or 82 for some Bf.109G
61 or 61+10 or 83 for Bf.109K

35/37 typically for Bf.109F
36 typically for Bf.109G

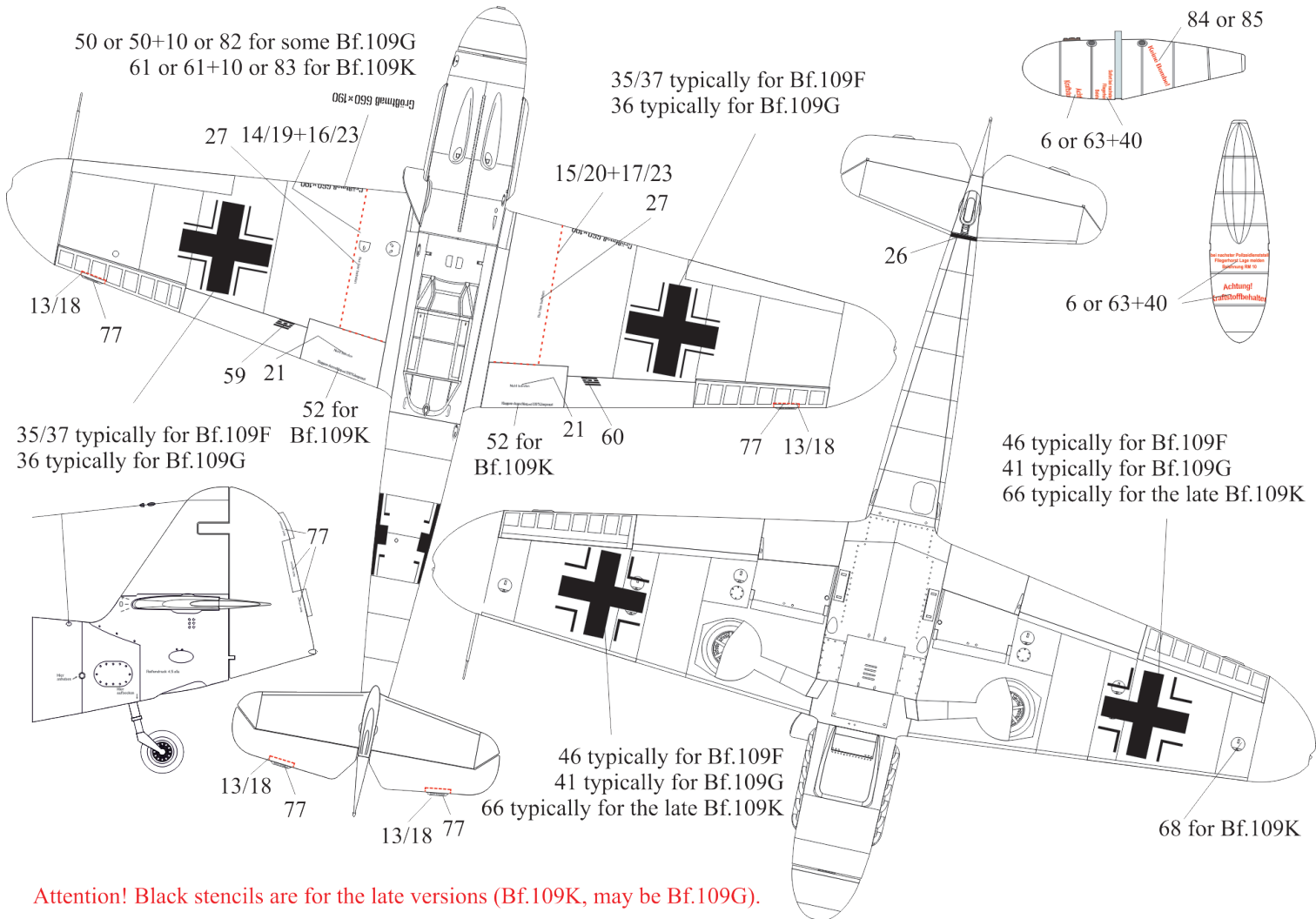

Attention! Black stencils are for the late versions (Bf.109K, may be Bf.109G).