

F-16 E/F



F-16E/F Desert Vipers Block 60 (2-in-1)

The F-16E/F is an F-16, but it is unlike any other F-16 variant in the world. The aircraft is more of a redevelopment of sorts the F-16 than just another incremental upgrade. Originally, when the program spun up in the 1990s, with an order eventually being placed for 80 advanced F-16s in 1998, the aircraft was going to be an even more drastic redesign of the F-16.

The Block 60 was designed for the United Arab Emirates Air Force (UAEAF). Based on the F-16C/D Block 50/52, it features improved radar, avionics and conformal fuel tanks. A major difference from previous blocks is the Northrop Grumman AN/APG-80 Active electronically scanned array (AESA) radar, which gives the airplane the capability to simultaneously track and destroy ground and air threats. The Block 60's General Electric F110-GE-132 engine is a development of the -129 model and is rated at 32,500 lbf (144 kN). The Electronic Warfare system is supposed to be quite advanced and includes the Northrop Grumman Falcon Edge Integrated Electronic Warfare Suite RWR together with the AN/ALQ-165 Self-Protection Jammer. Falcon Edge, which was developed by Northrop Grumman specifically for the Block 60, is capable of showing not only the bearing of any threat but also the range.

The Block 60 allows the carriage of all Block 50/52-compatible weaponry as well as AIM-132 Advanced Short Range Air-to-Air Missile (ASRAAM) and the AGM-84E Standoff Land Attack Missile (SLAM). The CFTs provide an additional 450 US gallon of fuel, allowing increased range or time on station. This has the added benefit of freeing up hardpoints for weapons that otherwise would have been occupied by underwing fuel tanks. The MIL-STD-1553 data bus is replaced by MIL-STD-1773 fiber-optic data bus which offers a 1,000 times increase in data-handling capability. UAE funded the entire \$3 billion Block 60 development costs, and in exchange will receive royalties if any of the Block 60 aircraft are sold to other nations. According to press reports quoted by Flight International, this is "the first time the US has sold a better aircraft [F-16] overseas than its own forces fly". Like the F-35, the Block 60 F-16 has a built in FLIR/laser targeting system rather than using a dedicated pod that would occupy a hardpoint, increase drag and RCS.

CAUTION

- *Read carefully and fully understand the instructions before commencing assembly.
- *Keep out of reach of children. Children must not be allowed to put any parts in their mouths, or pull plastic bag over their heads.
- *When using adhesives and paints, please make sure not to use them in closed room or near the fire.
- *When assembling this kit, tools including knives are used. Extra care should be taken to avoid injury.

WARNING: CONTAIN SMALL PARTS NOT FOR CHILDREN UNDER 14 YEARS OF AGE.

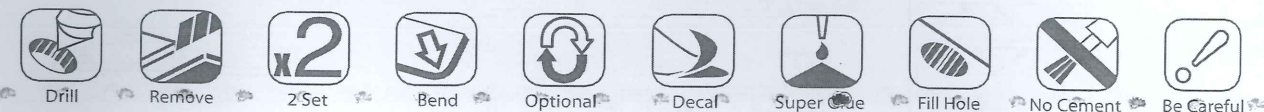

TOOLS RECOMMENDED



AFTERMARKET SERVICES CARD

When requesting replacement parts, please take or send this form to your local dealer so that the parts required can be correctly identified. Please note that specifications and availability are subject to change without notice. Or visit <http://www.kineticmodel.com> for latest information. For more information, please contact services@kineticmodel.com

Part Code	K48136	Qty	Item	Part Code	Qty	Item
00-100-011	F-16 SINGLE SEAT FRONT FUESLAGE PARTS A	1	A	00-100-040	1	F-16 LOWER FUESLAGE
00-100-012	F-16 TWO SEATER FRONT PARTS B	1	B	00-100-043	1	DORSAL SPINE PARTS
00-100-013	F-16 MAIN PARTS 0207 - PARTS C	1	C	00-100-044	1	F-16I LOWER FUSELAGE PARTS
00-100-014	F-16 PARTS - 370 GAL FUEL TANK (PARTS D)	2	D	00-100-046	1	CFT PARTS (DOUBLE SEATER)
00-100-018	F-16 BLOCK 40/50 LANDING GEEAR PARTS H	1	H	00-100-048	1	F-16E/F MAIN PARTS
00-100-019	MCID INTAKE - PARTS I	1	I	00-100-051	1	BLOCK 60E VERTICAL FIN
00-100-021	WEAPON SET (AIM-9x,9M,120B/C,GBU-12) PARTS M	2	M	00-100-052	1	BLOCK 60F BACK SPINE
00-100-022	CLEAR PARTS FOR F-16 - PARTS Z	1	Z	00-100-053	1	CFT FOR SINGLE SEAT F-16
00-100-034	UPPER BACK FUESLAGE TYPE (C/D) PARTS C/D	1		01-100-001	1	F-16 STENCIL DECAL
00-100-036	NOSE CONE FOR F-16 BLOCK 60	1	NOSE CONE	01-100-009	1	F-16E/F UAE DECAL FOR #48008
00-100-037	F-16 TWO SEATER CANOPY	1	CANOPY	03-100-48136	1	1/48 F-16E/F UAE
00-100-038	F-16 SINGLE SEAR CANOPY FRONT/REAR PART	1	CANOPY	06-100-001	1	1/48 CFT parts for F-16
00-100-039	F-16 SINGLE CANOPY BACK PART	1	CANOPY			

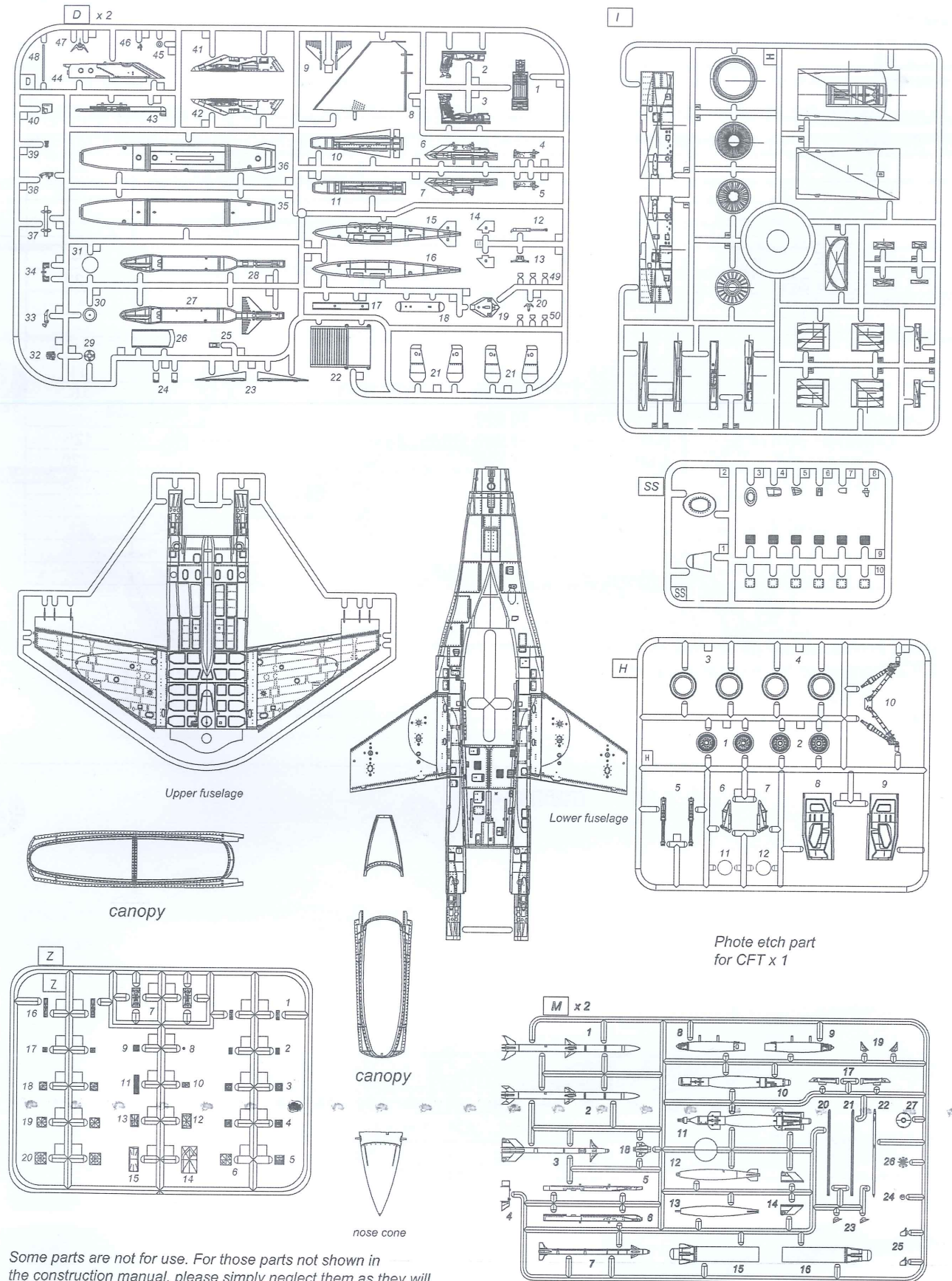
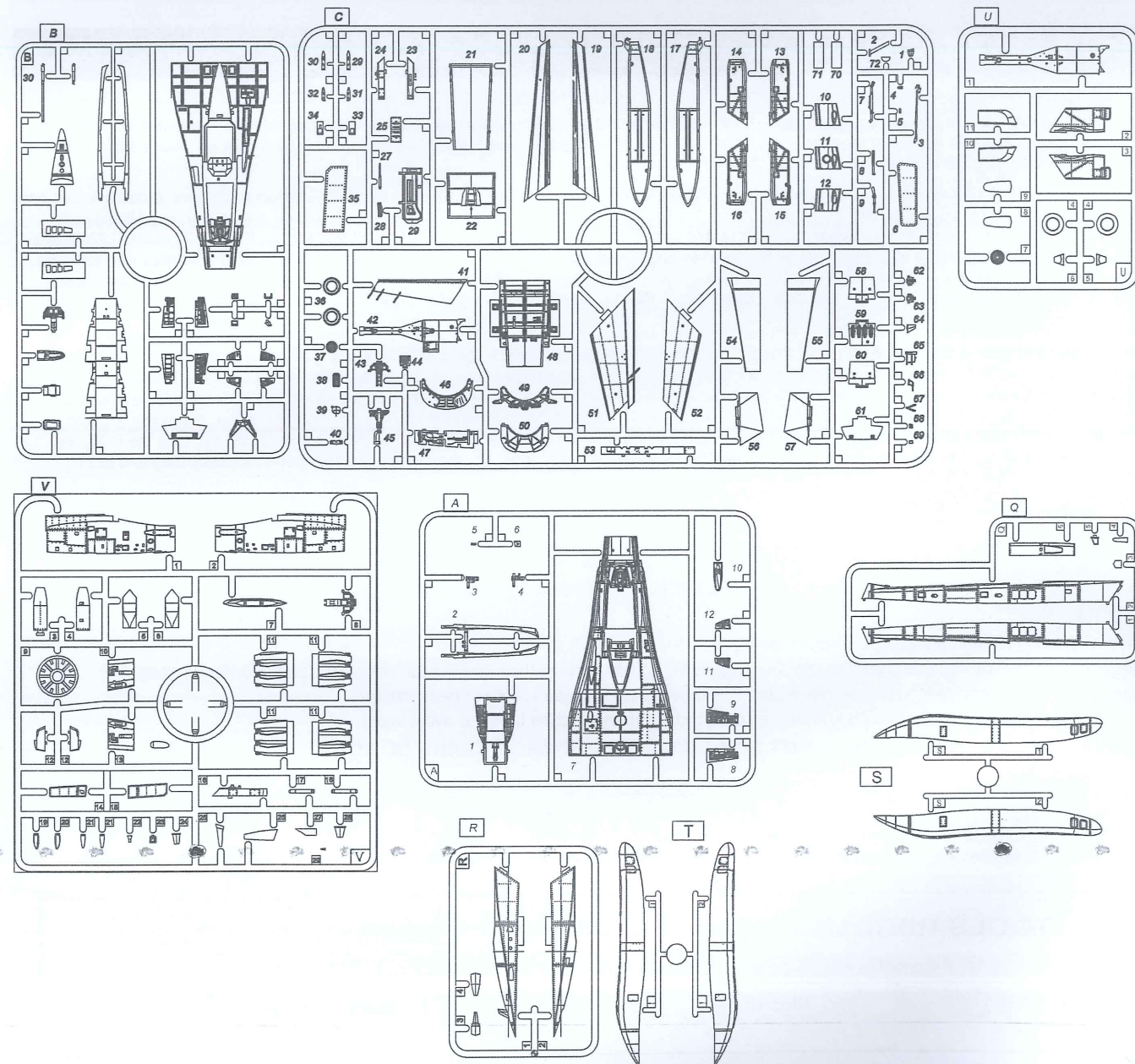

Some parts are not for use. For those parts not shown in the construction manual, please simply neglect them as they will not be used for building this model.



COLOR	AMMO MIG	VALLEJO MODEL COLOR	GSI CREOS MR. COLOR	TAMIYA ENAMEL/ACRYLIC	HUMBROL ENAMEL
GUN METAL	A.MIG-045	70.863	78	X-10	53
MATT BALCK	A.MIG-046	71.057	33	XF-1	33
SATIN WHITE	A.MIG-047	70.842	1	X-2	22
YELLOW	A.MIG-048	71.002	4	XF-3	69
BLUE	A.MIG-086	71.089	323/5	X-4	14
CRYSTAL RED	A.MIG-093	70.934	47	X-27	220
CRYSTAL BLUE	A.MIG-098	70.938	50	X-23	-
BURNT IRON	A.MIG-187	71.073	61	XF-4	-
STEEL	A.MIG-191	70.864	28	-	27003
SILVER	A.MIG-195	71.063	8	X-11	11
GOLD	A.MIG-198	71.066	9	X-12	16
GHOST GRAY FS 36375	A.MIG-203	70.990	308	-	-
GUNSHIP GRAY	A.MIG-204	71.047	305	XF-77	125
FS36320	A.MIG-208	71.120	307	-	128
FS336270	A.MIG-211	71.275	306	-	126
DARK OILVE DRAB	A.MIG-237	71.016	12	XF-62	-
SATIN BLACK	A.MIG-032	70.861	2	X-18	21
CLEAR YELLOW	-	70.937	48	X-24	-
FS 36495	A.MIG-209	71.276	338	-	-

For Color Profile, please go to www.kineticmodel.com for download
(type the kit# and go for manual/painting guide)

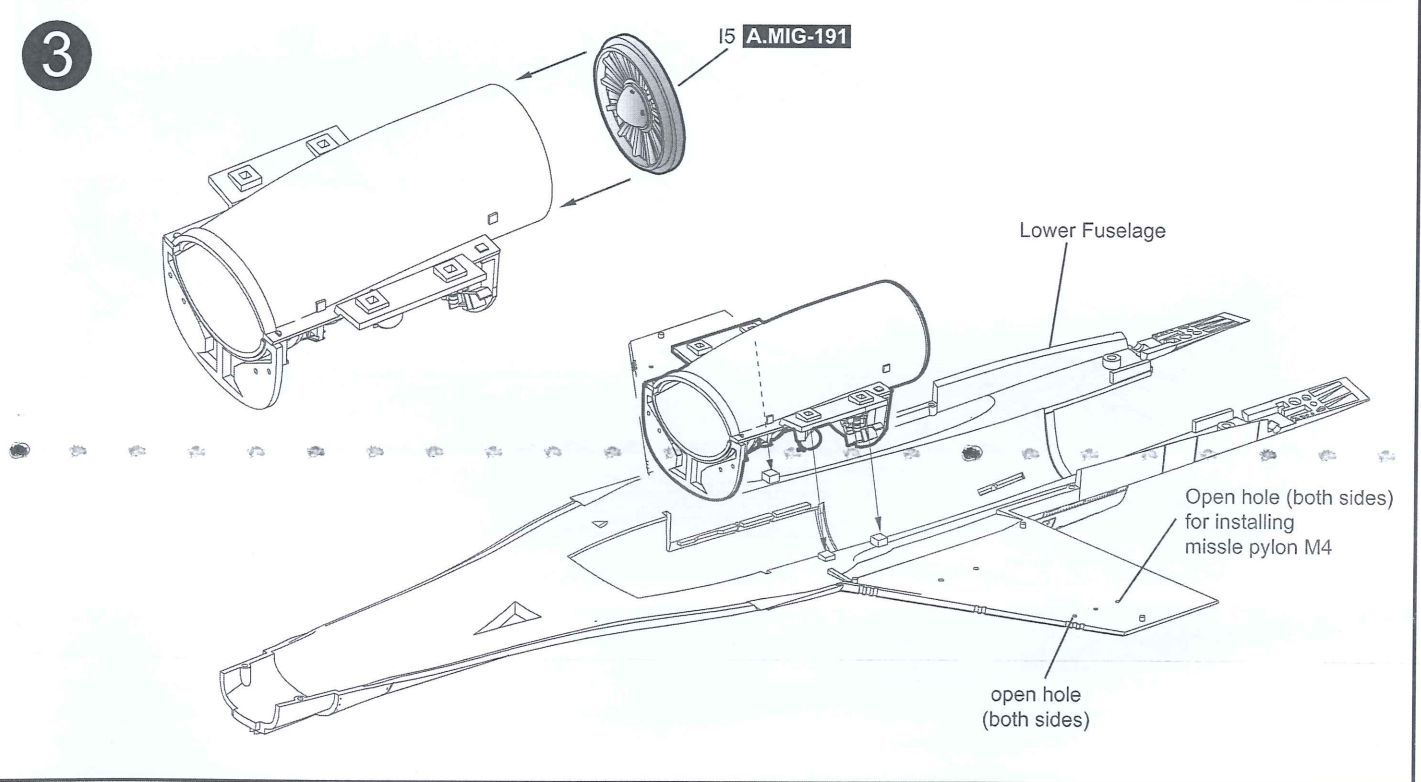
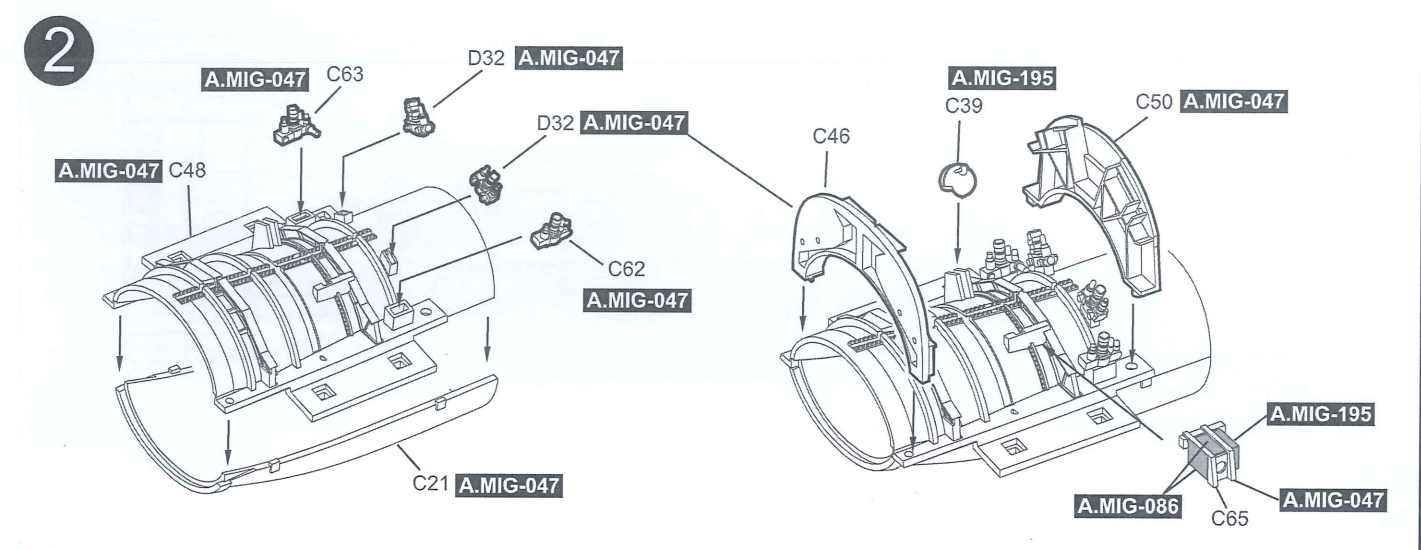
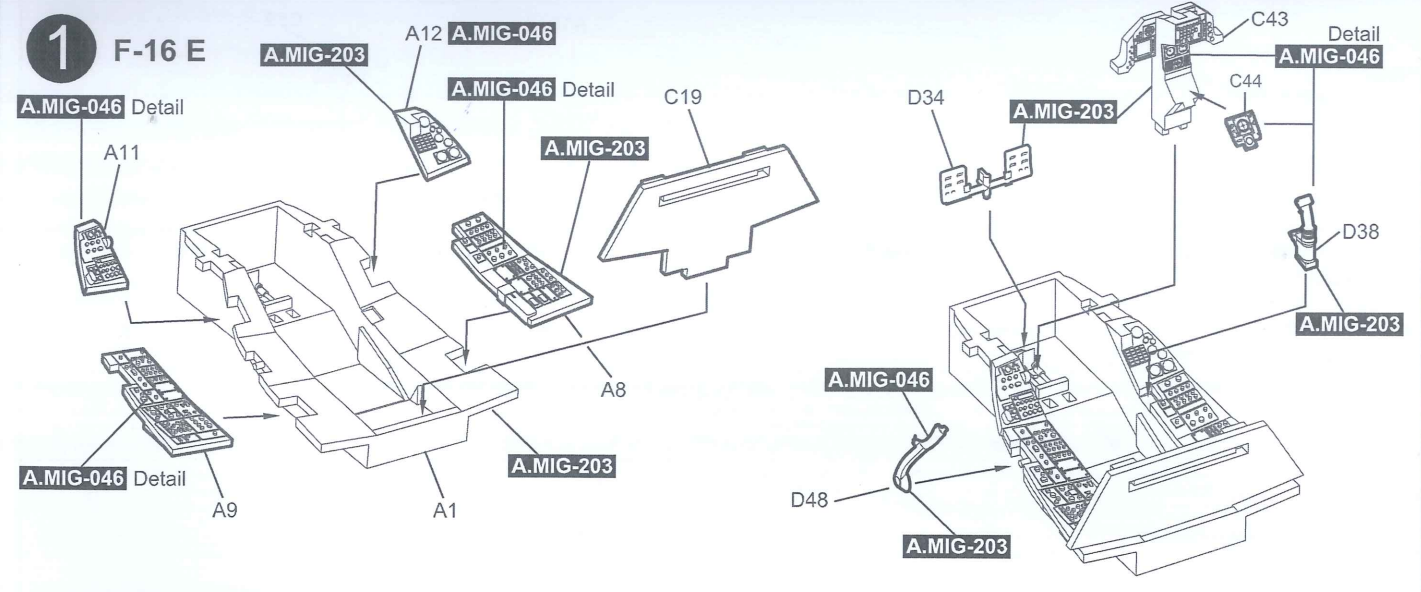

4

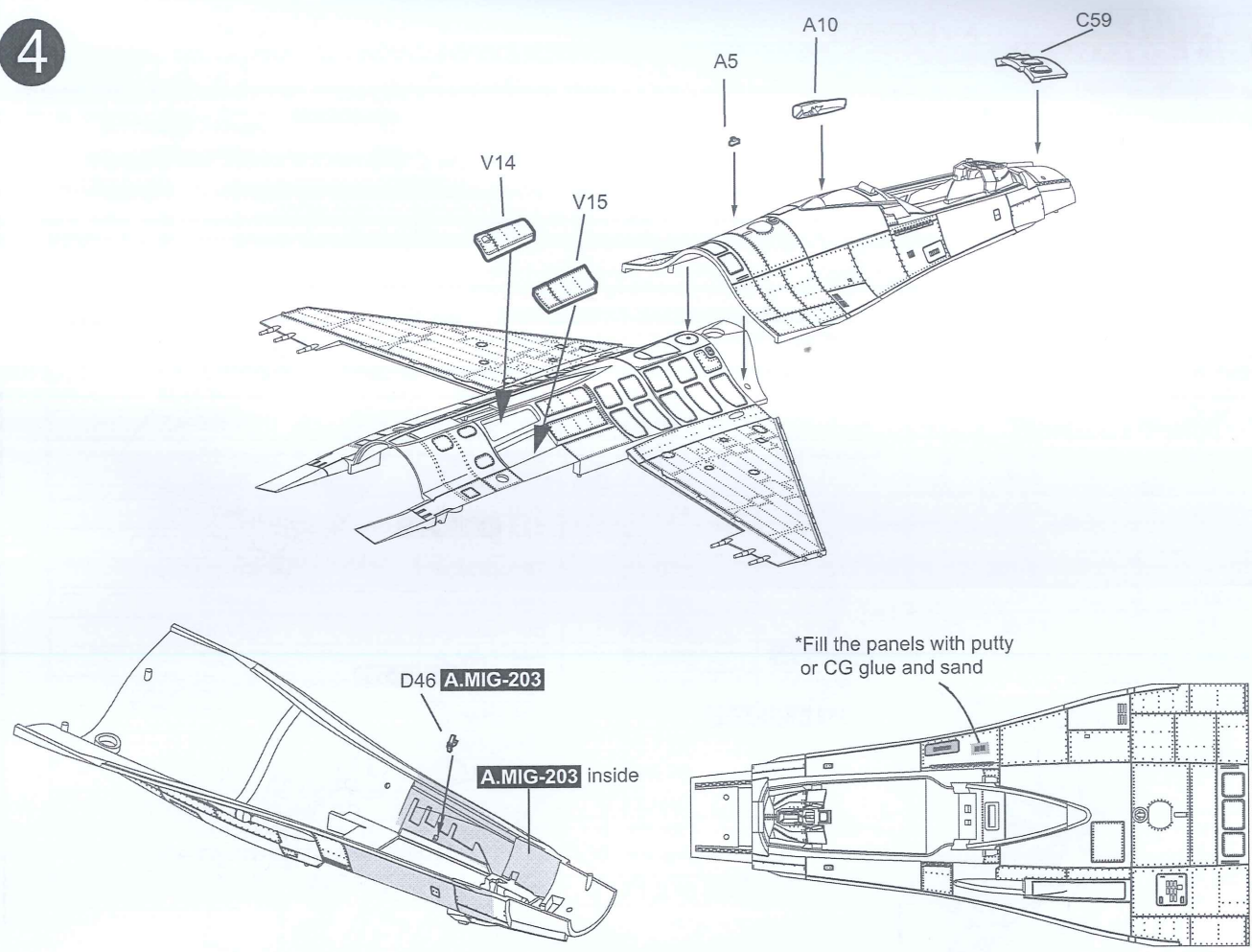

6

Cut along the lines for open air brake

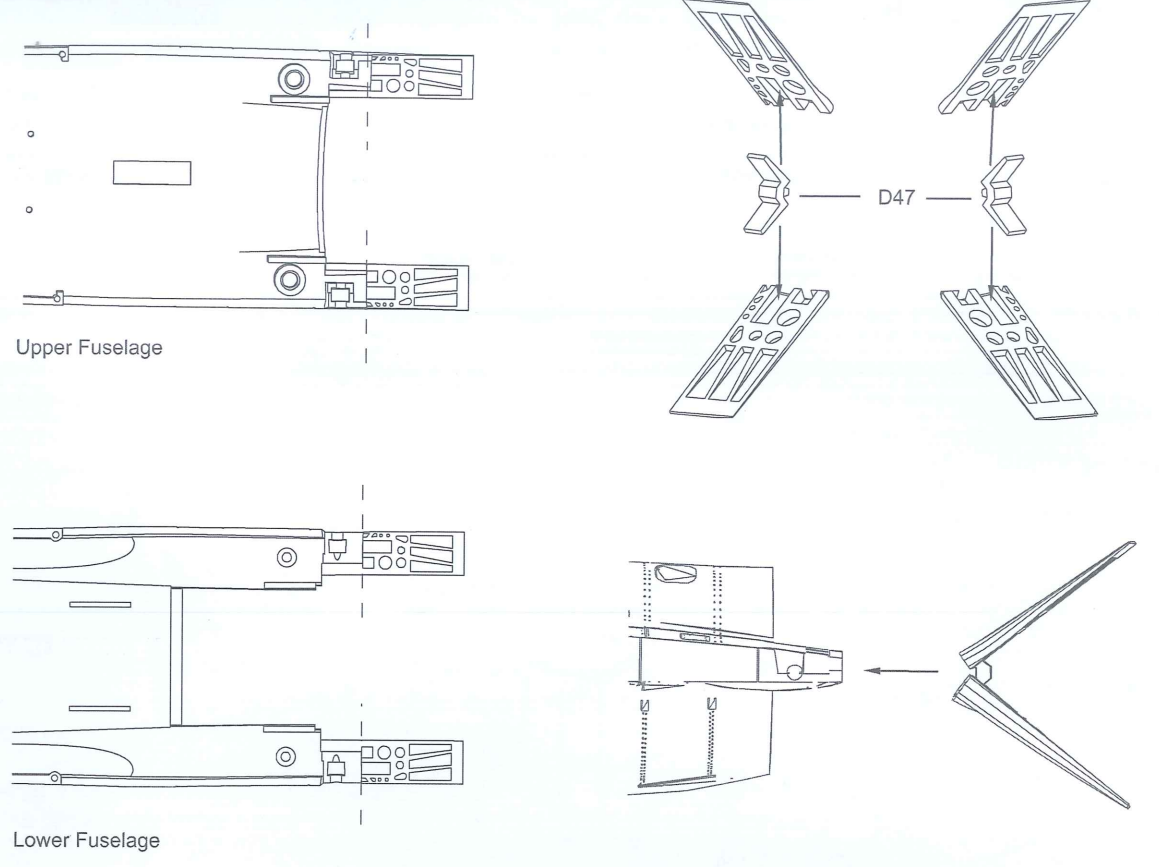

5

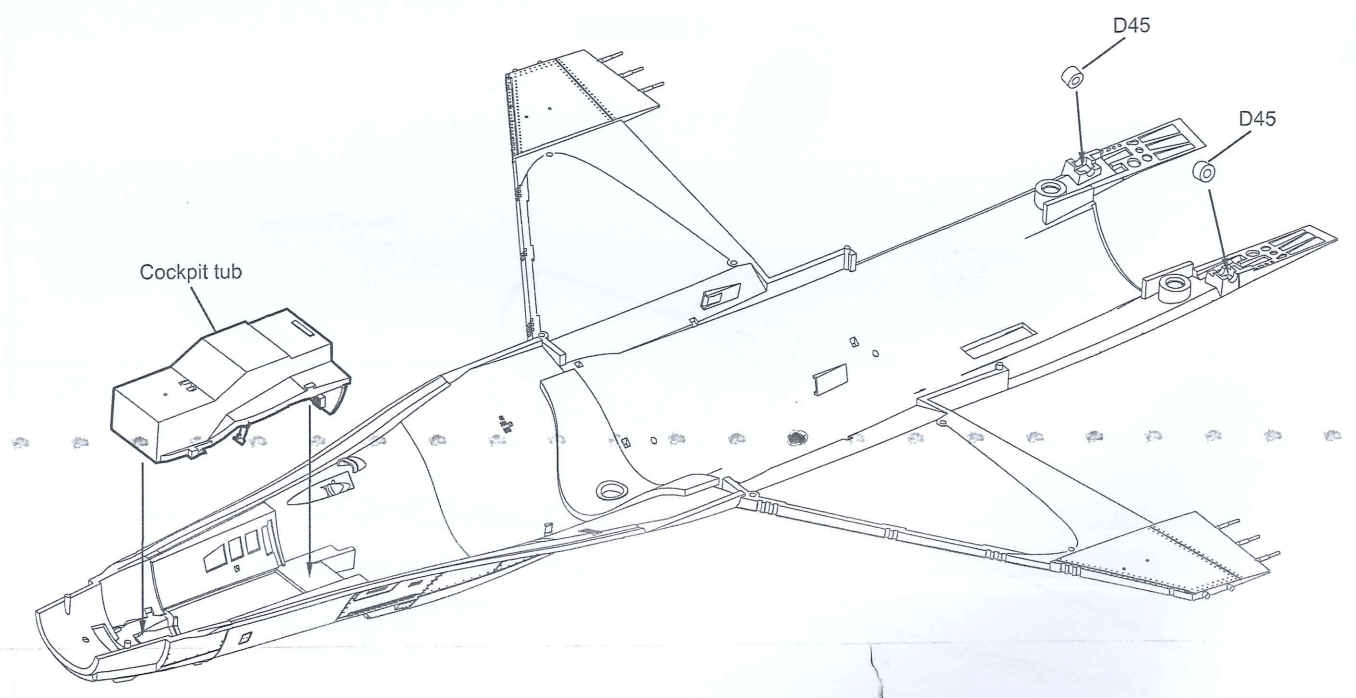

7

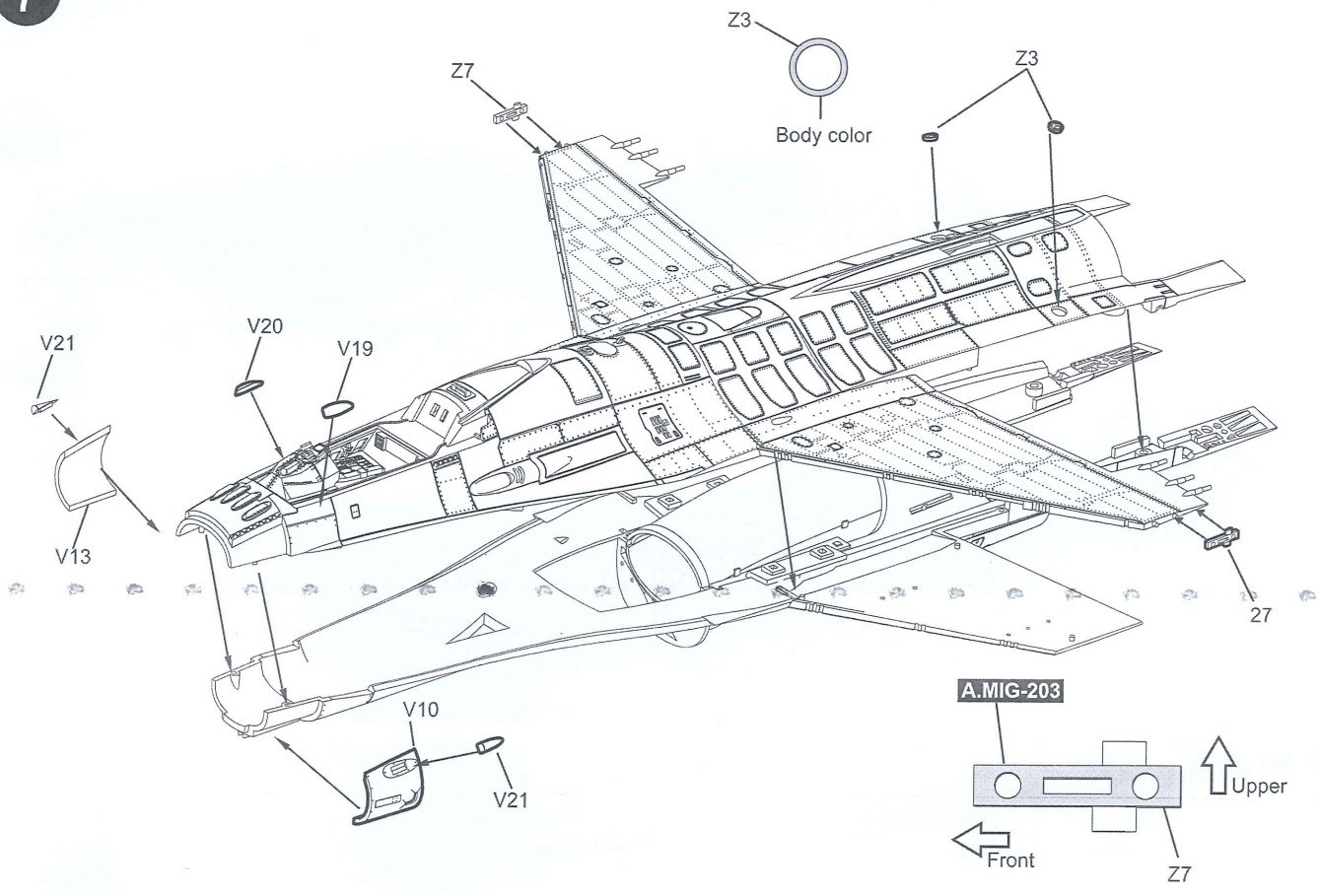

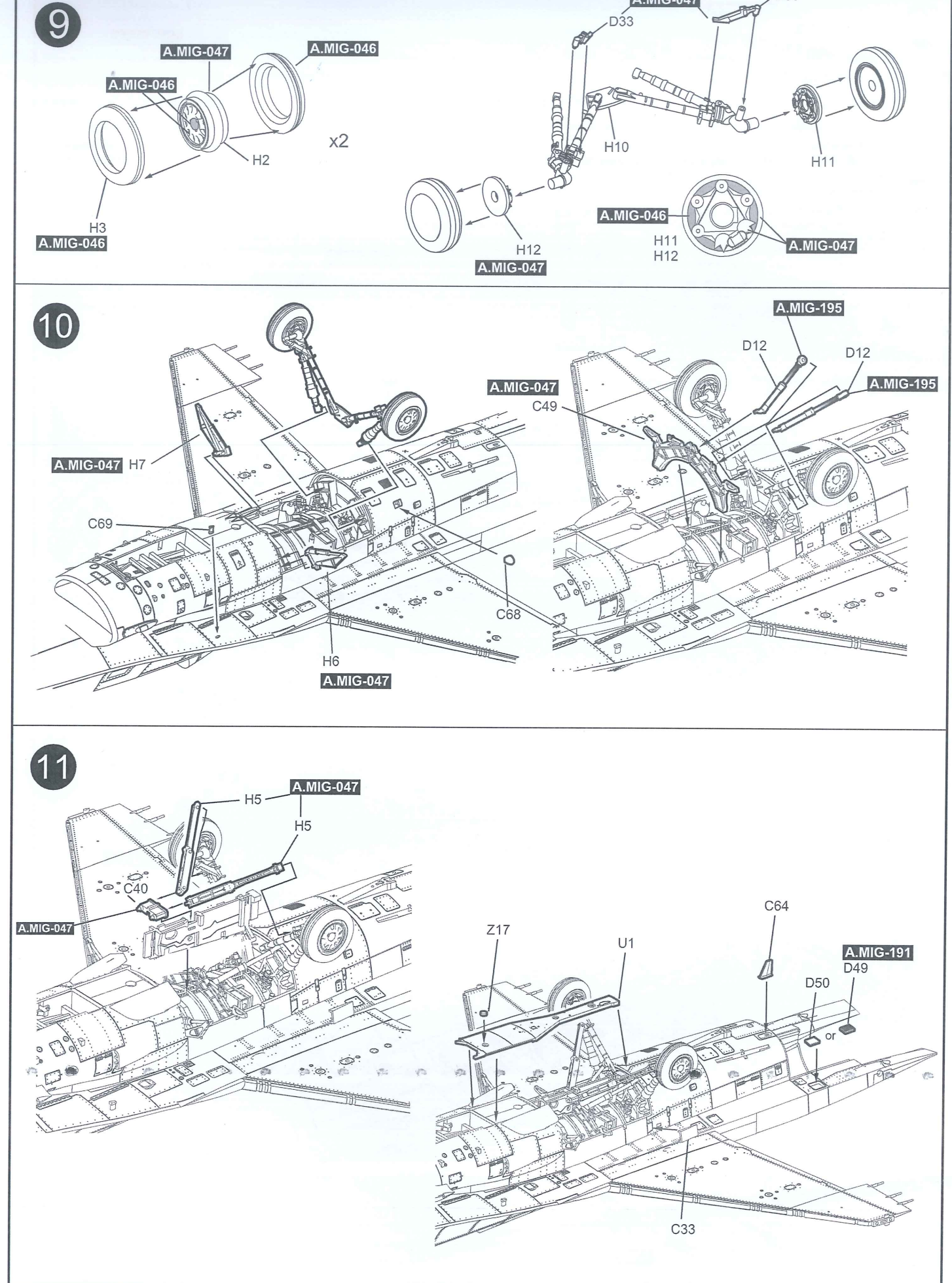
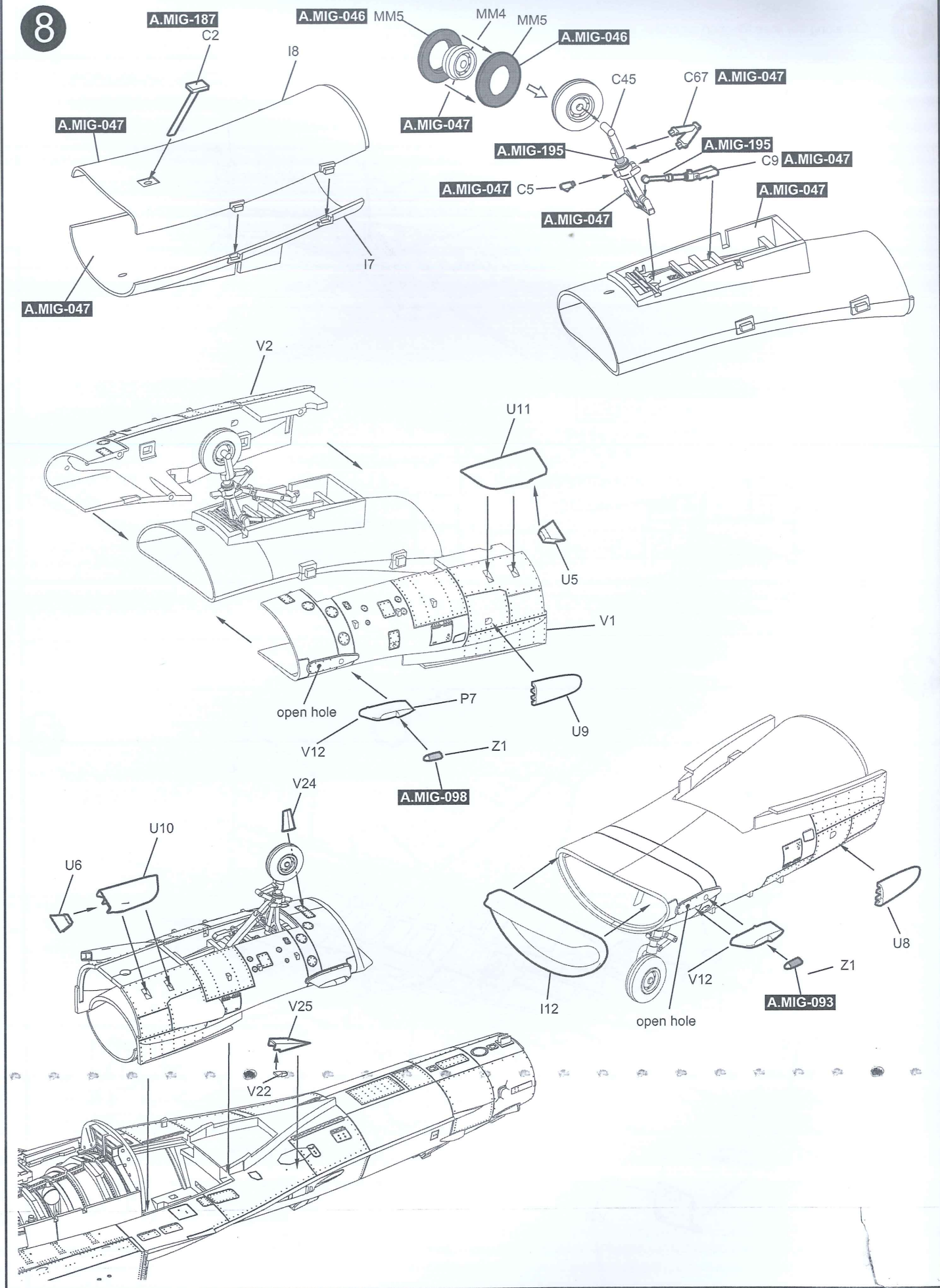

12

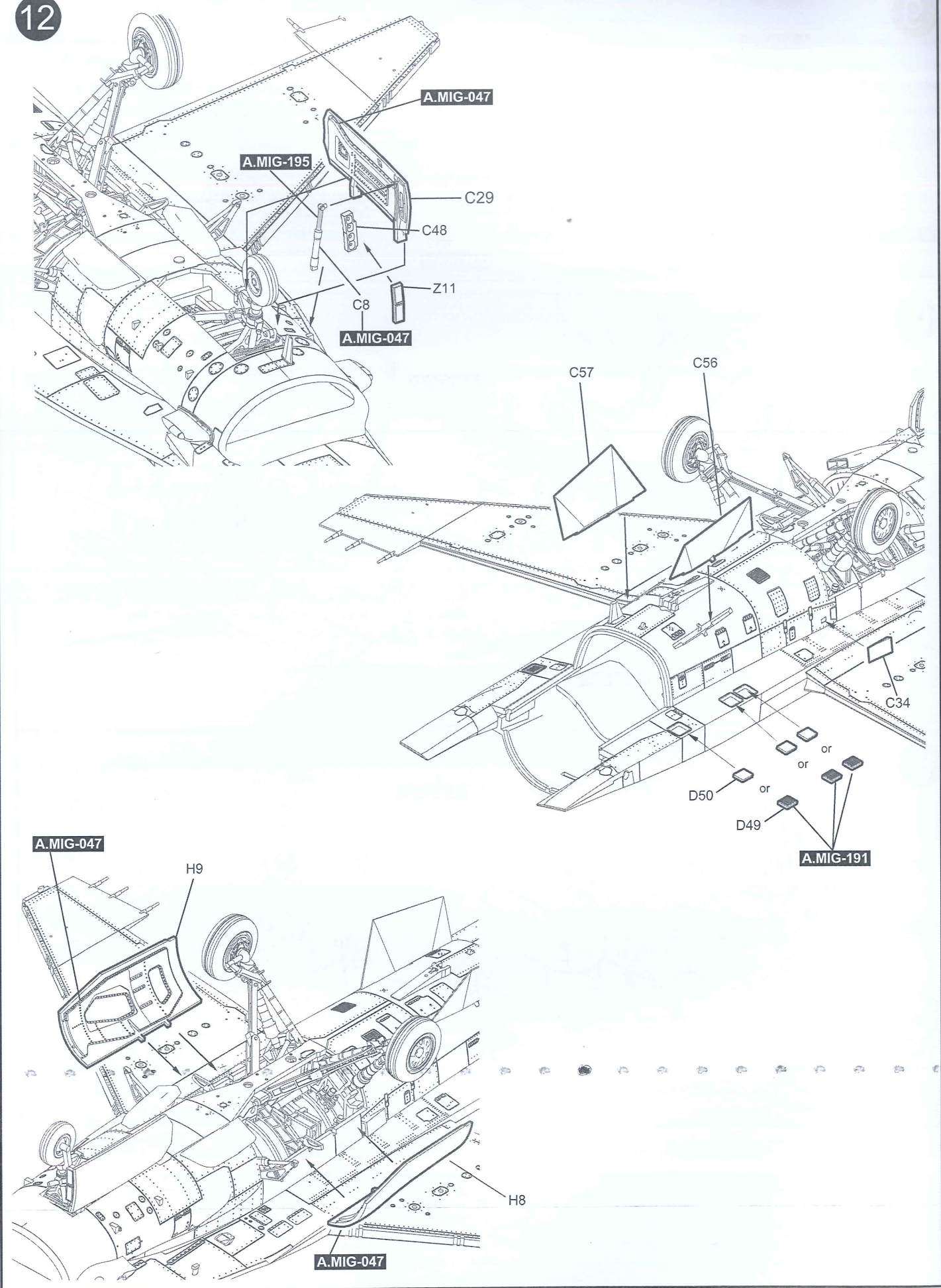

13

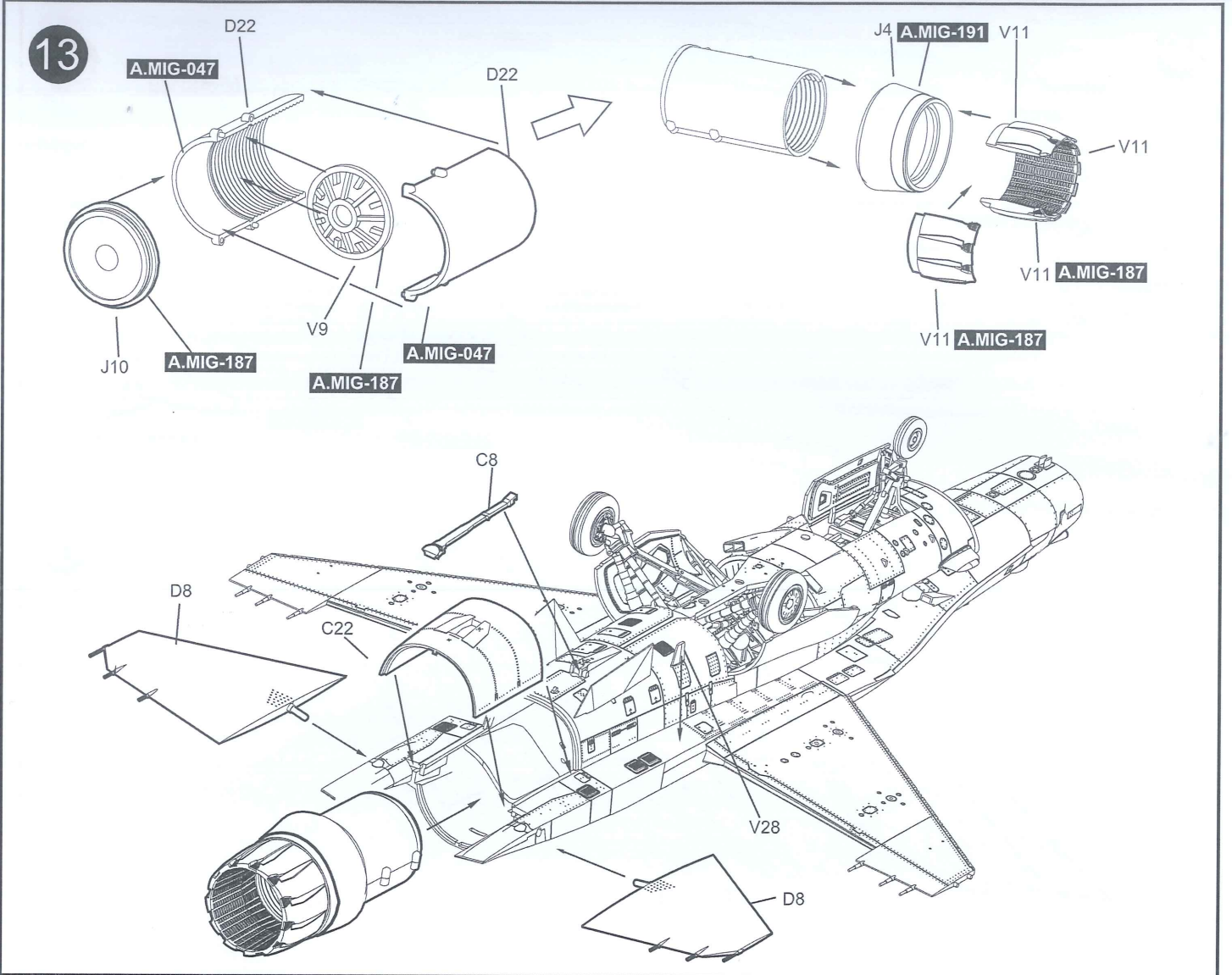

14

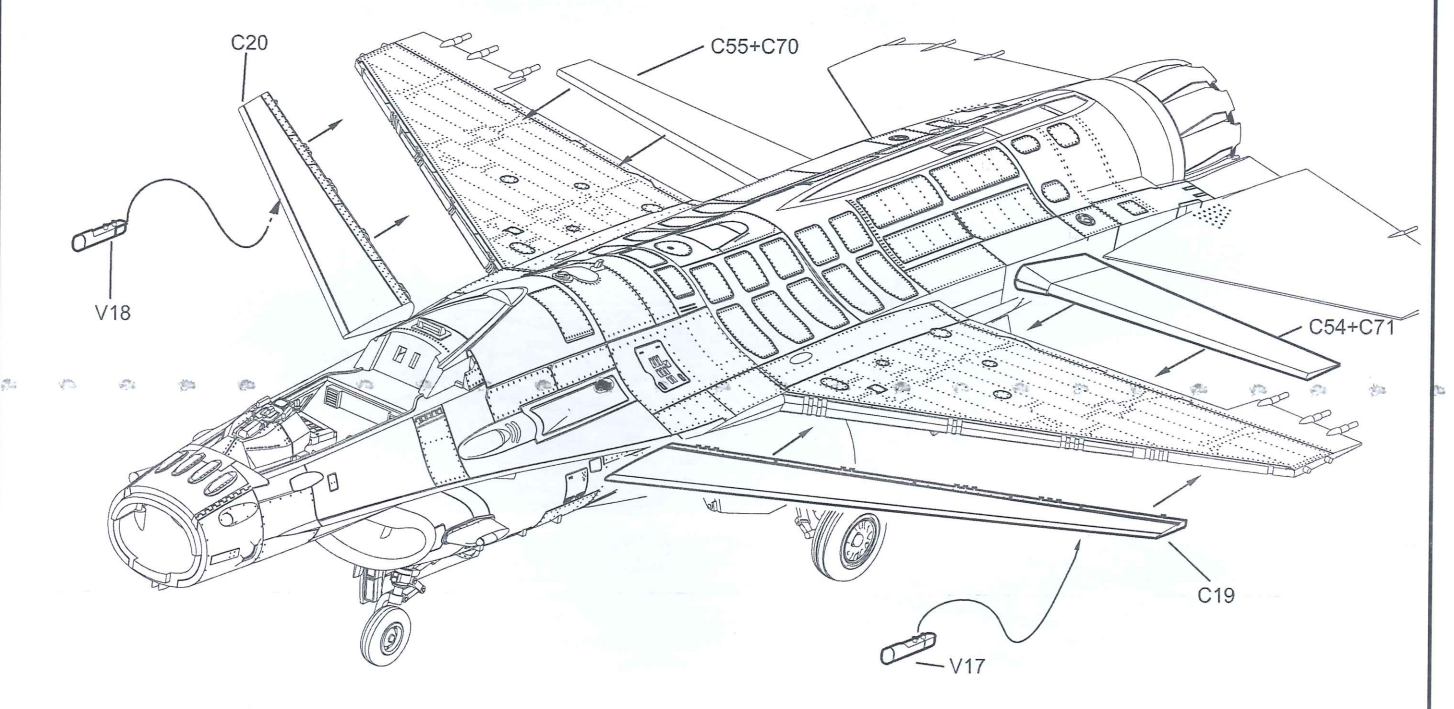

15

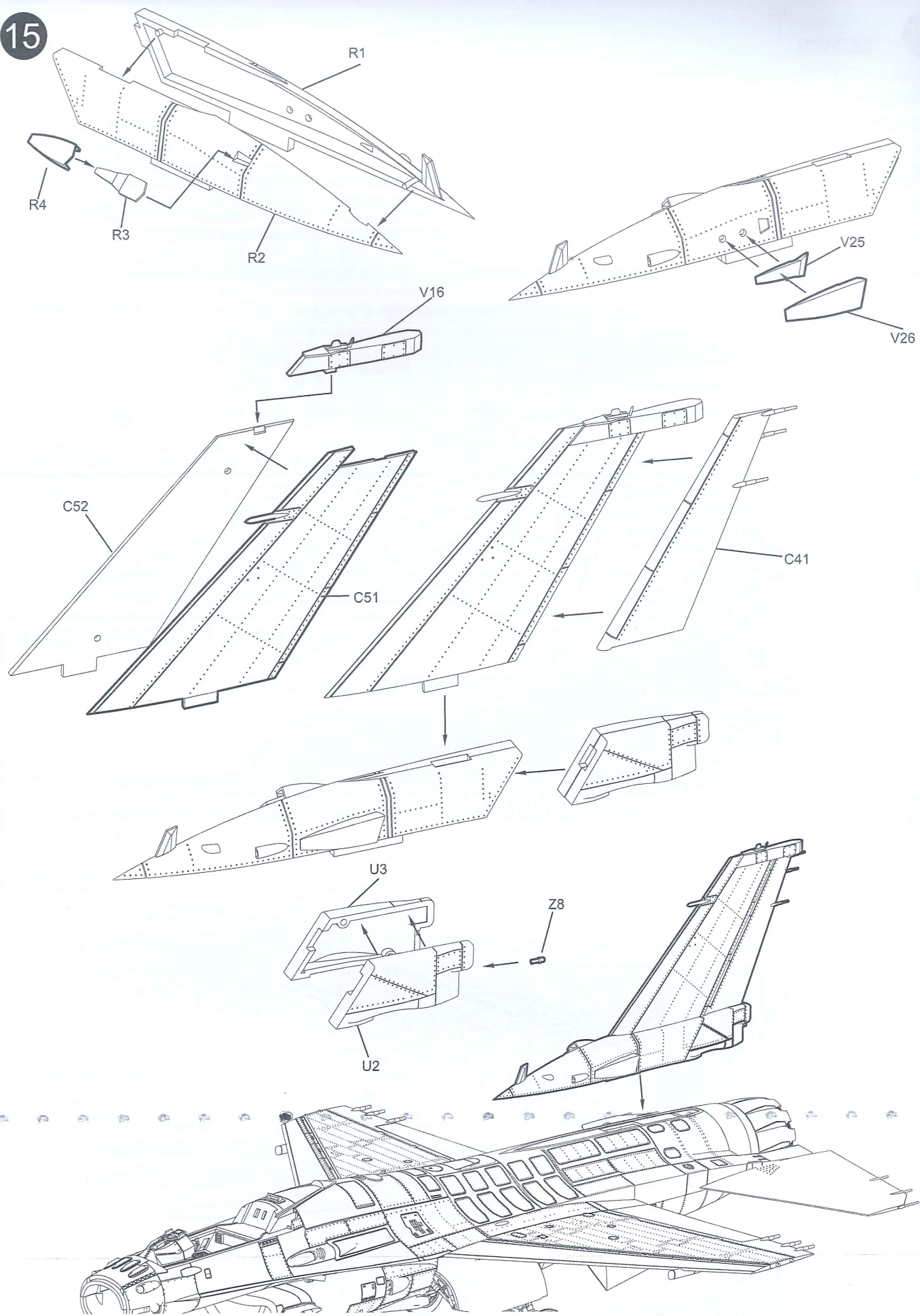

16

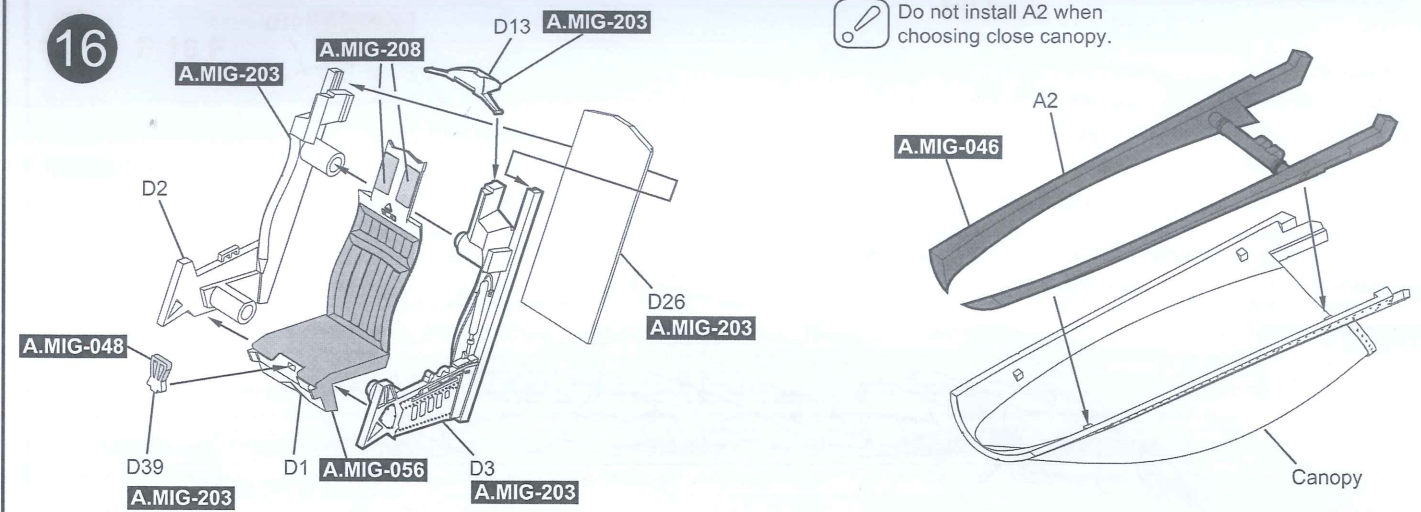

Do not install A2 when choosing close canopy.

17

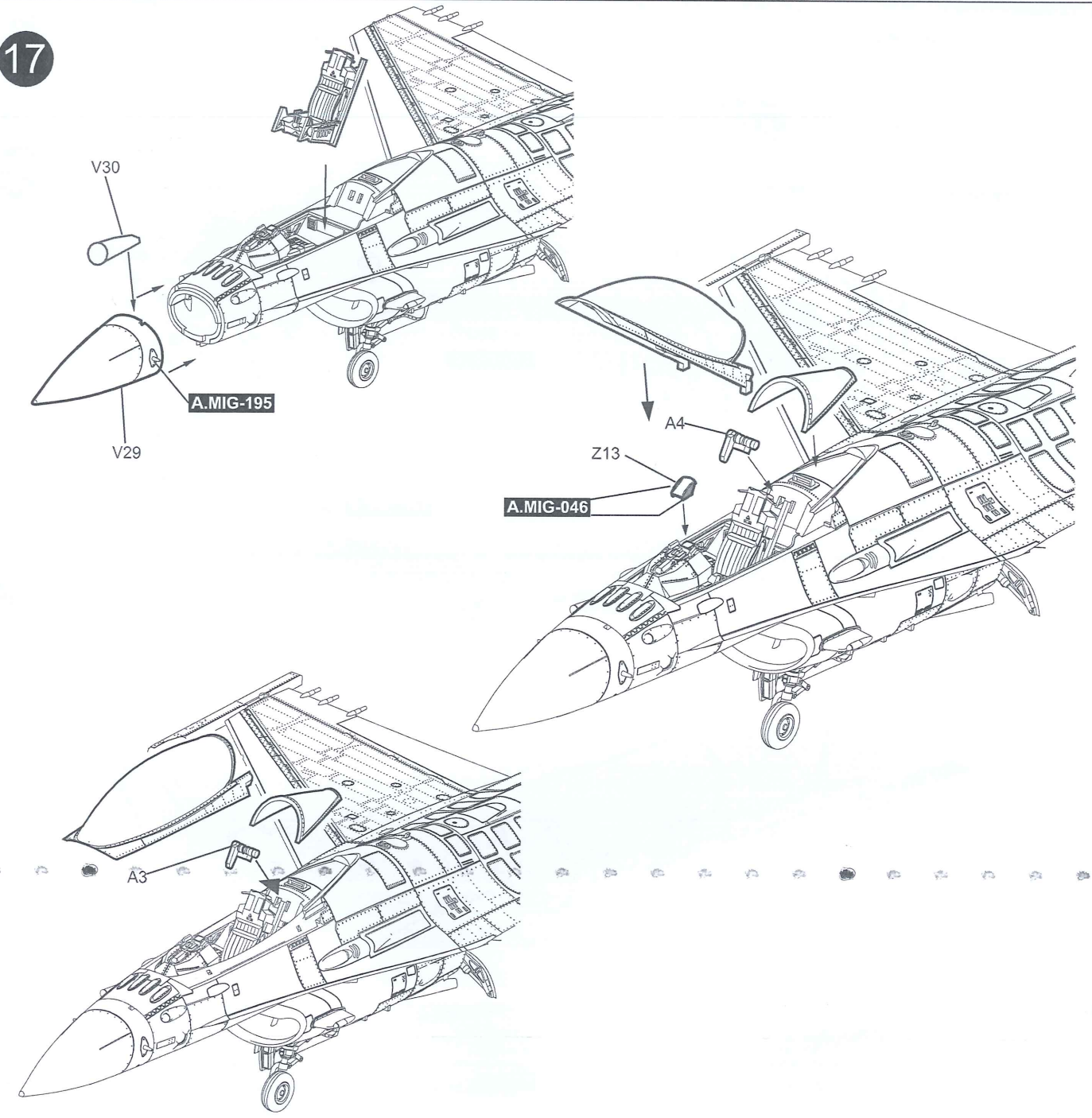

18 CFT Installation

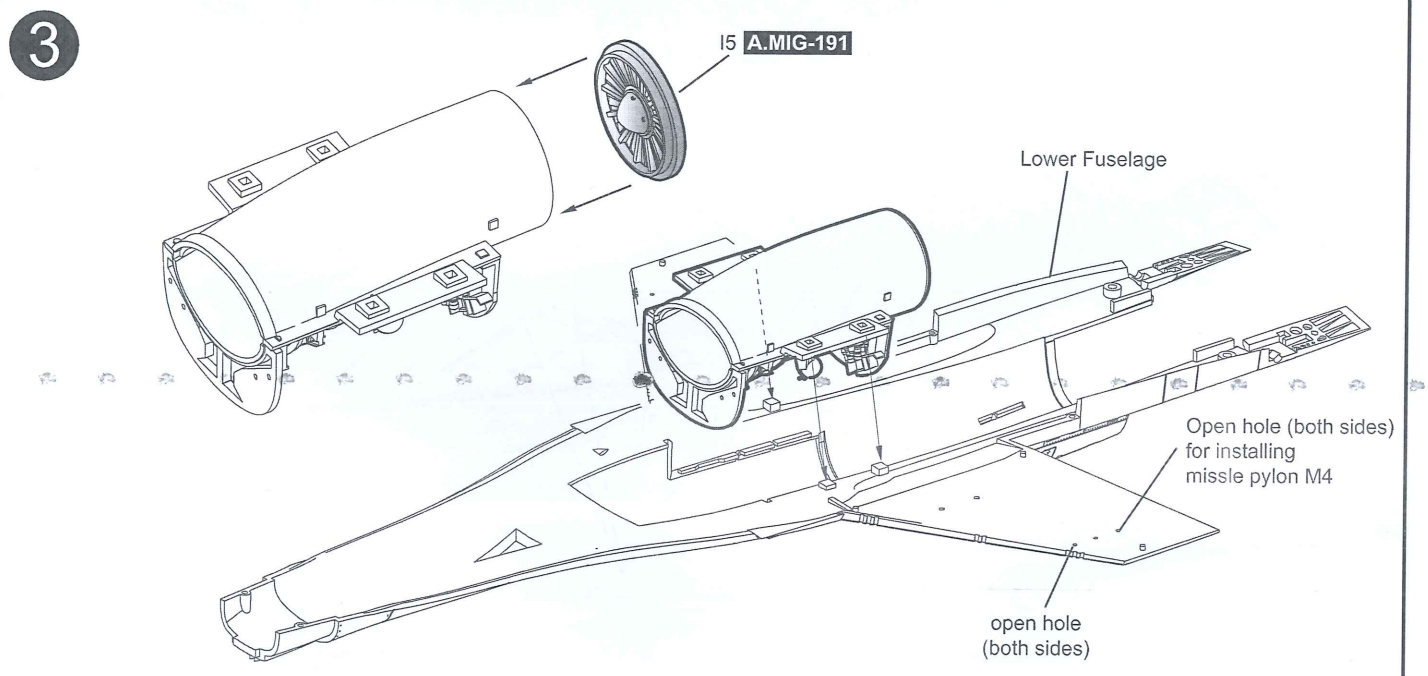
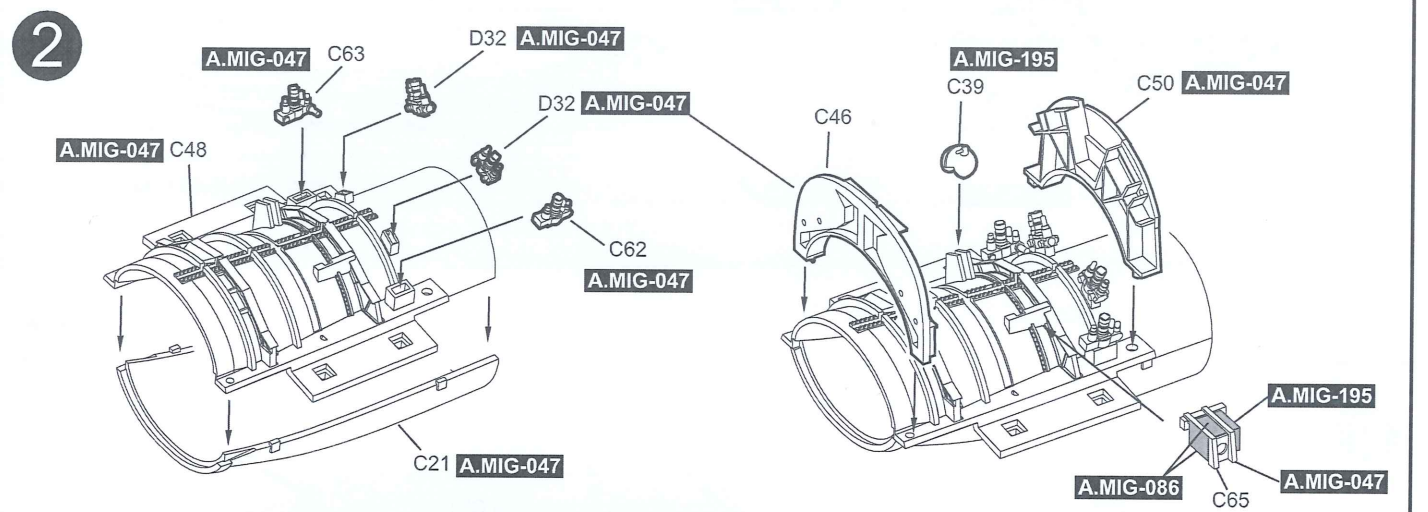
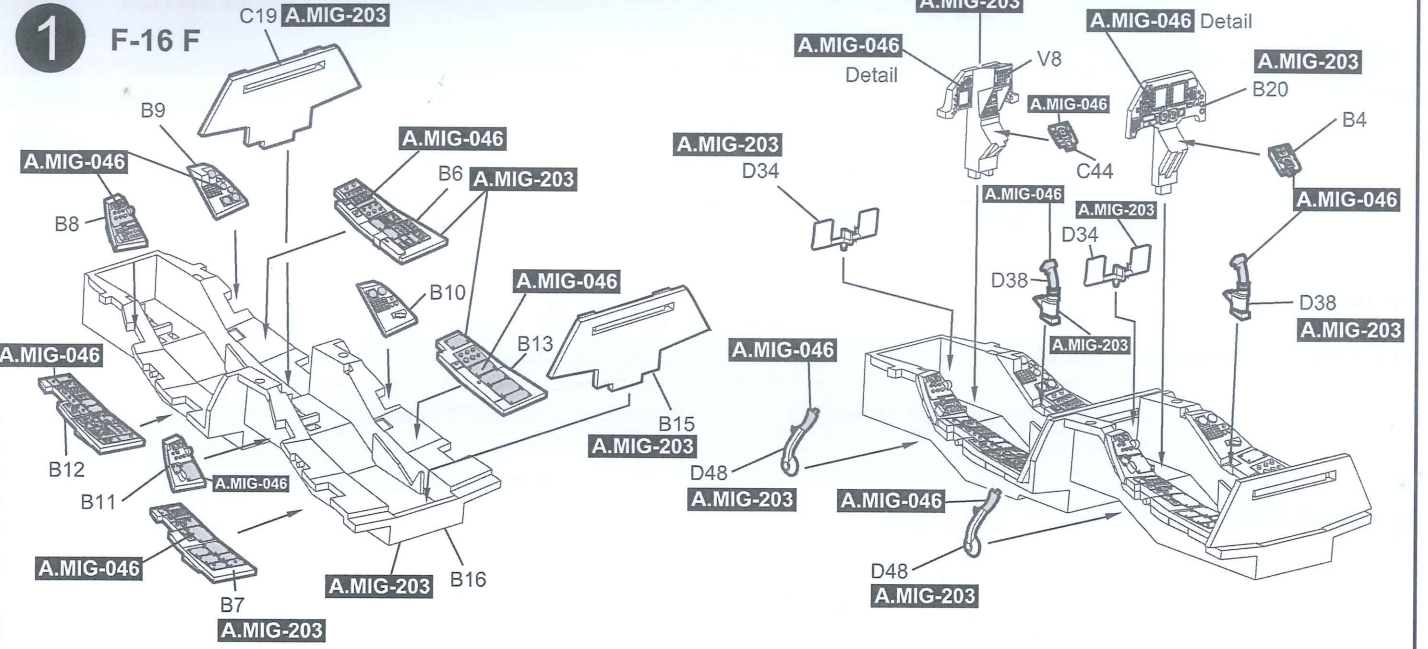
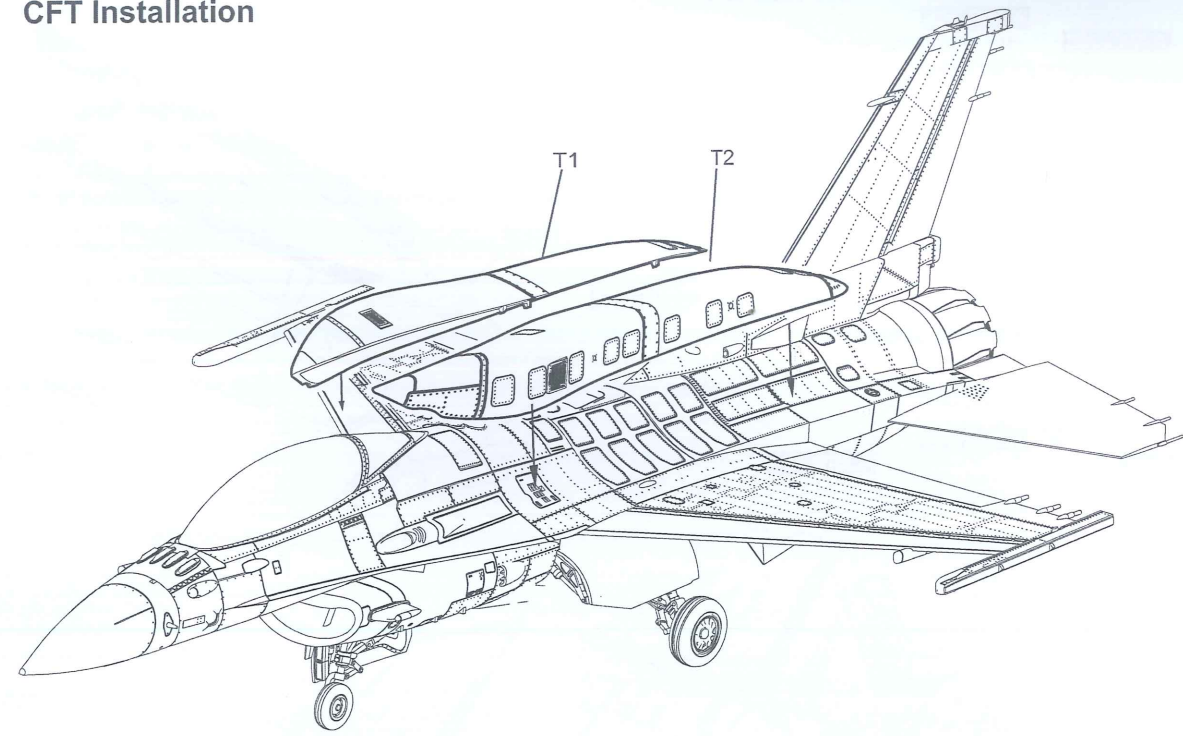

4

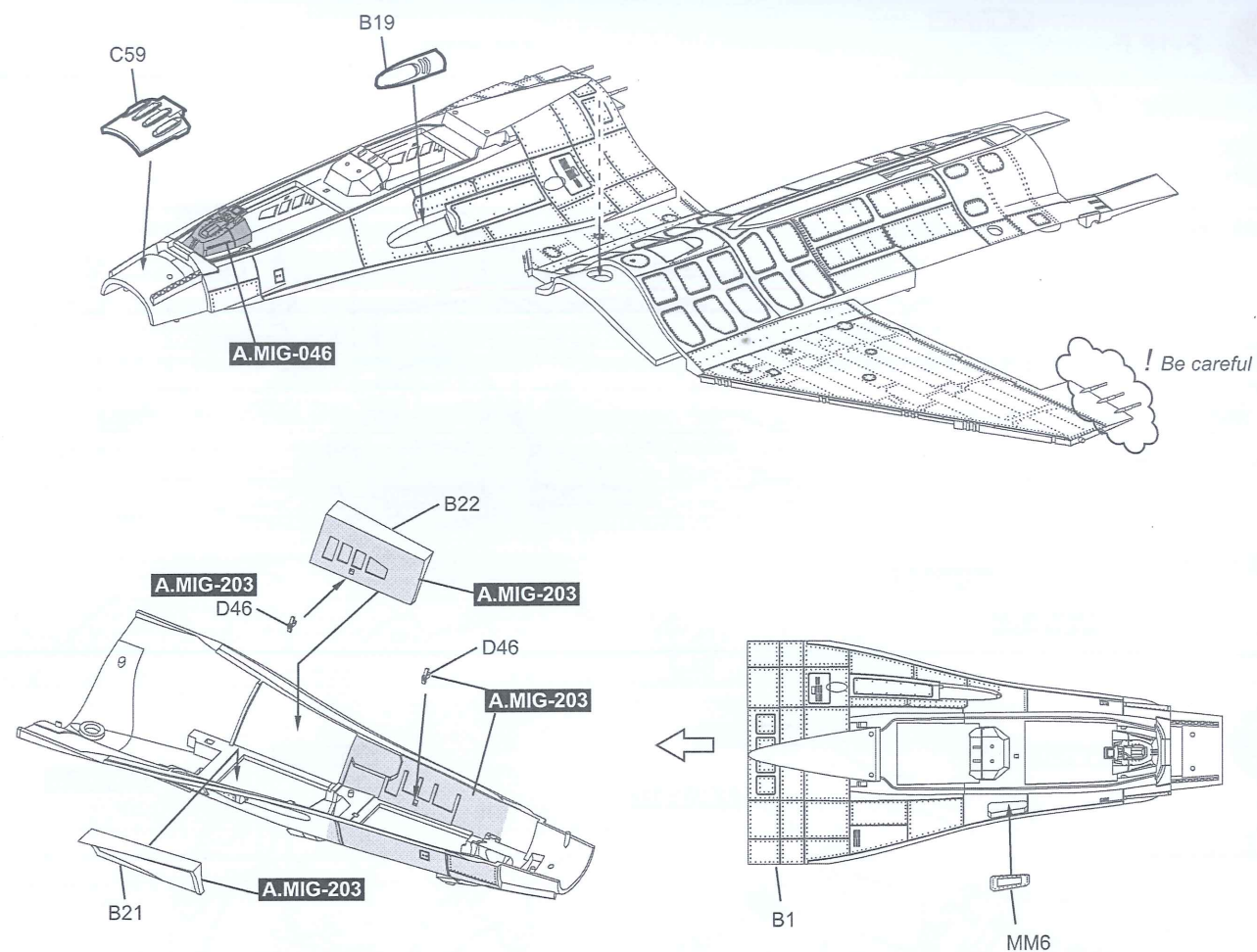

5

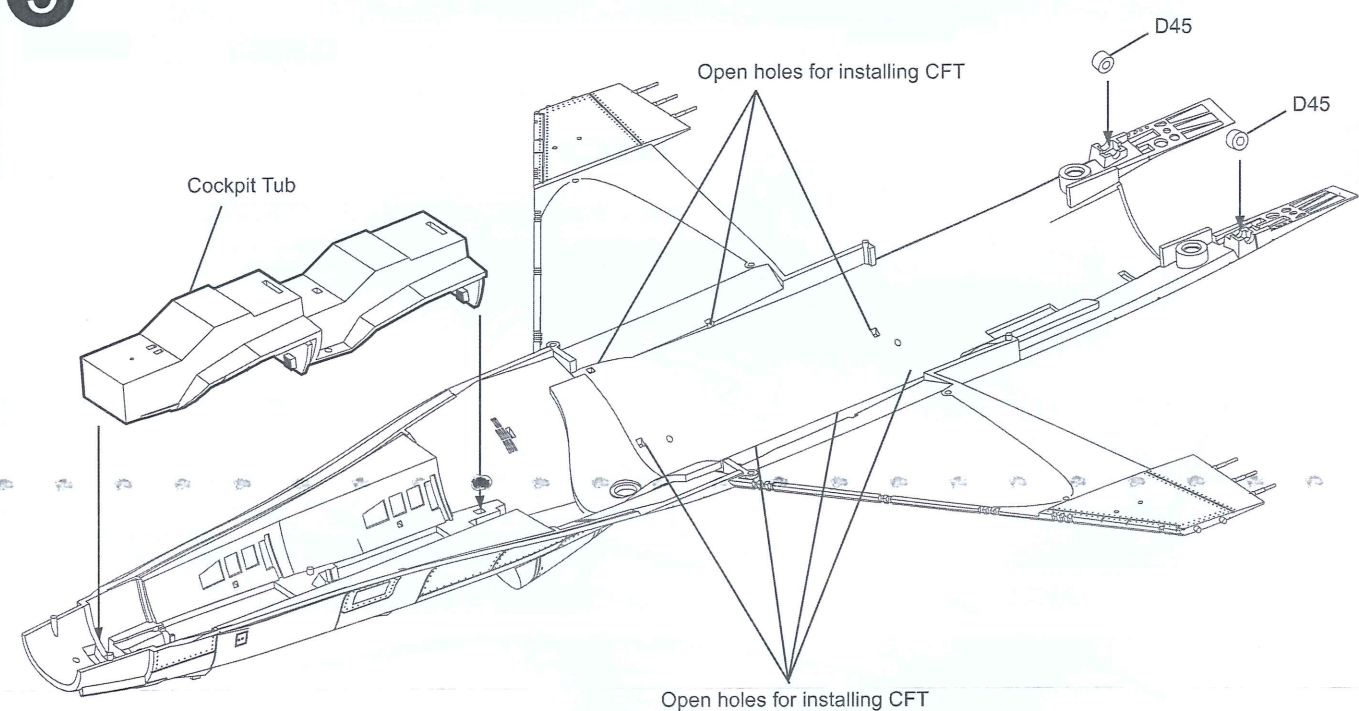

6

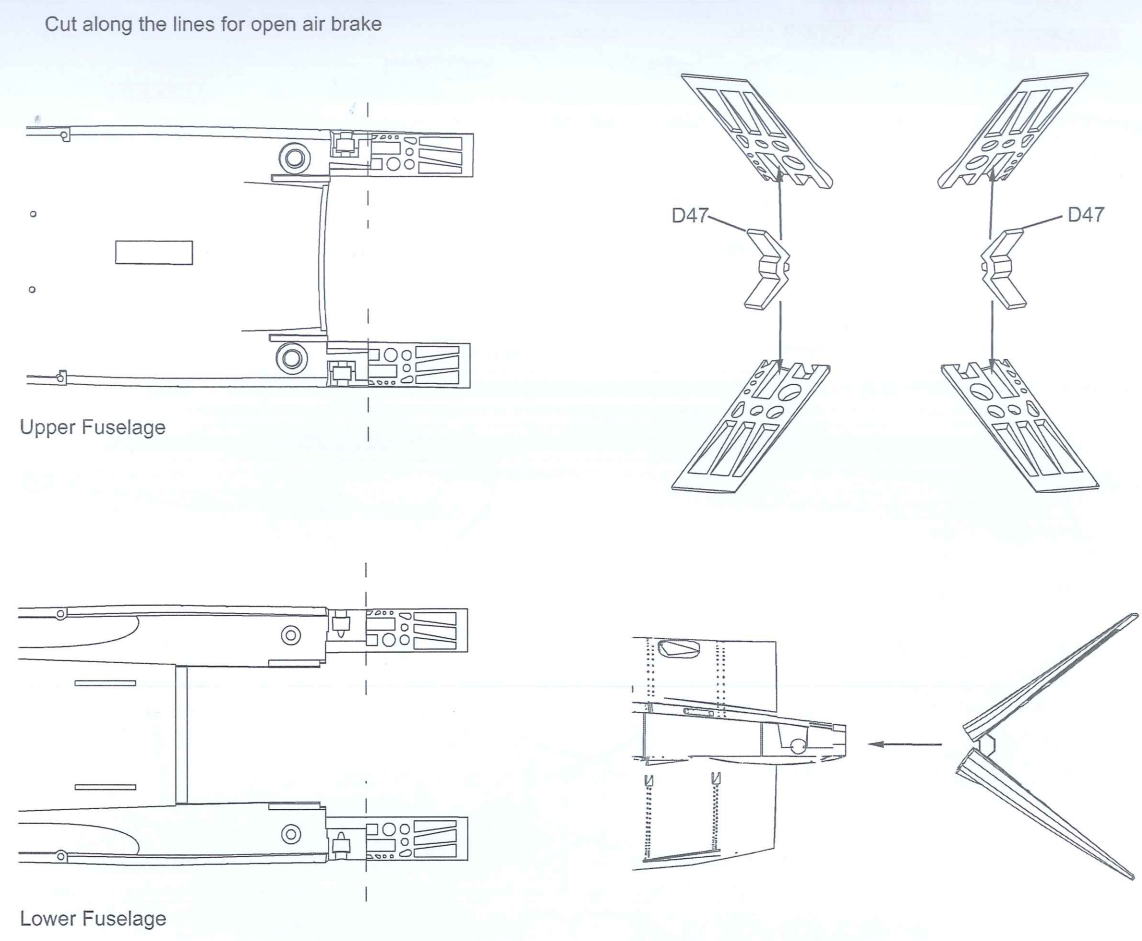

7

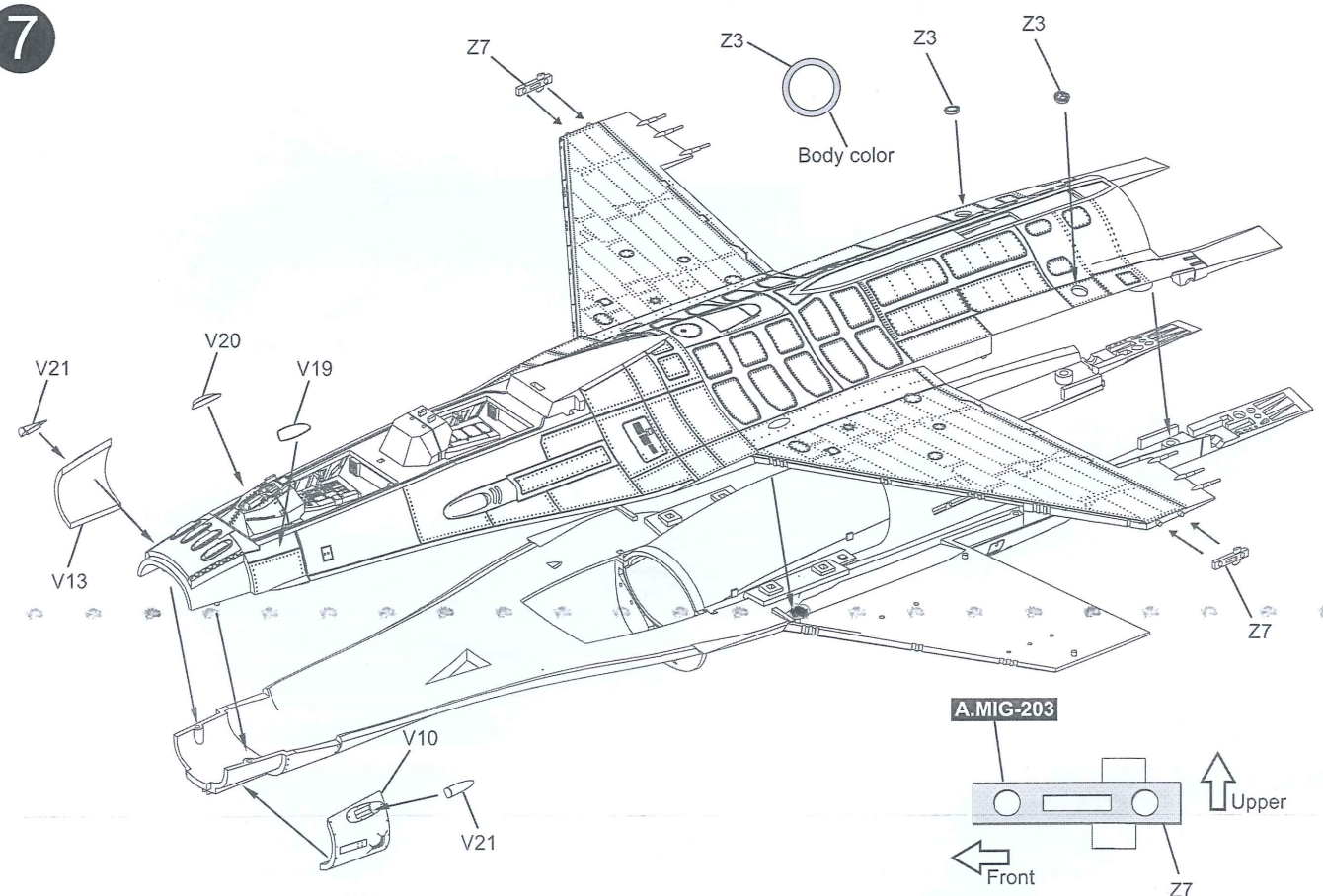

8

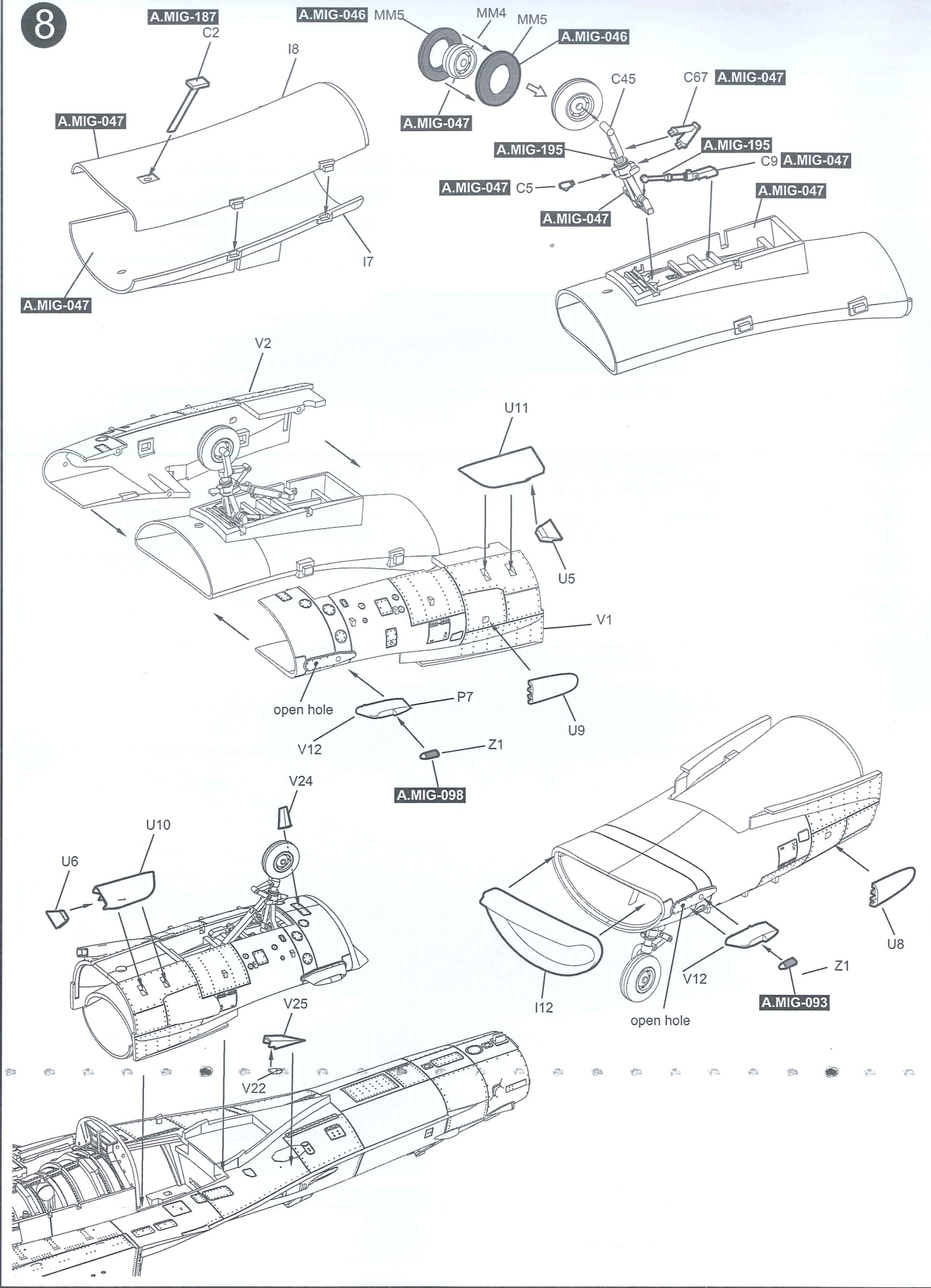

9

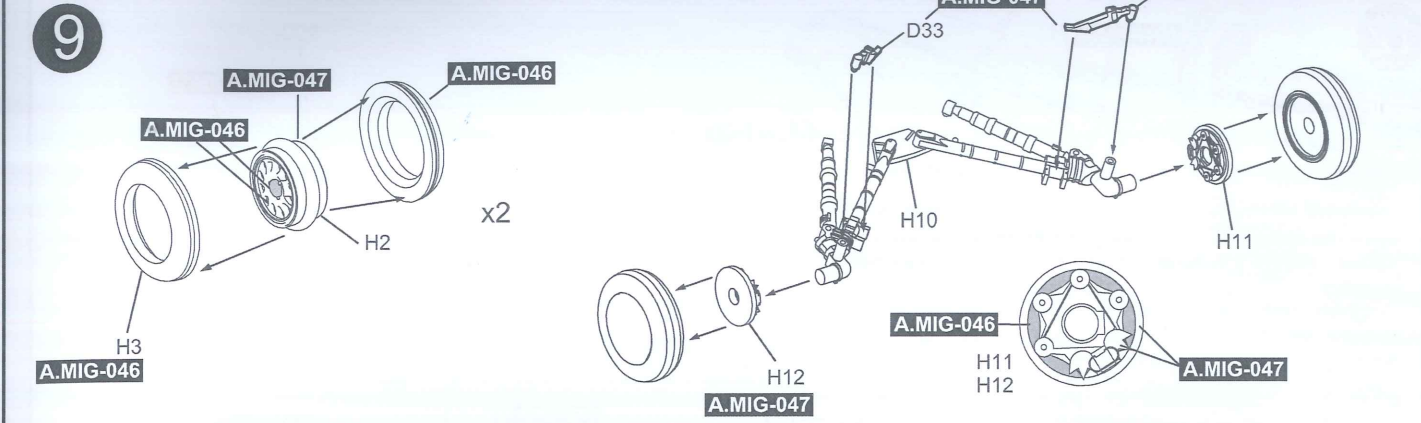

10

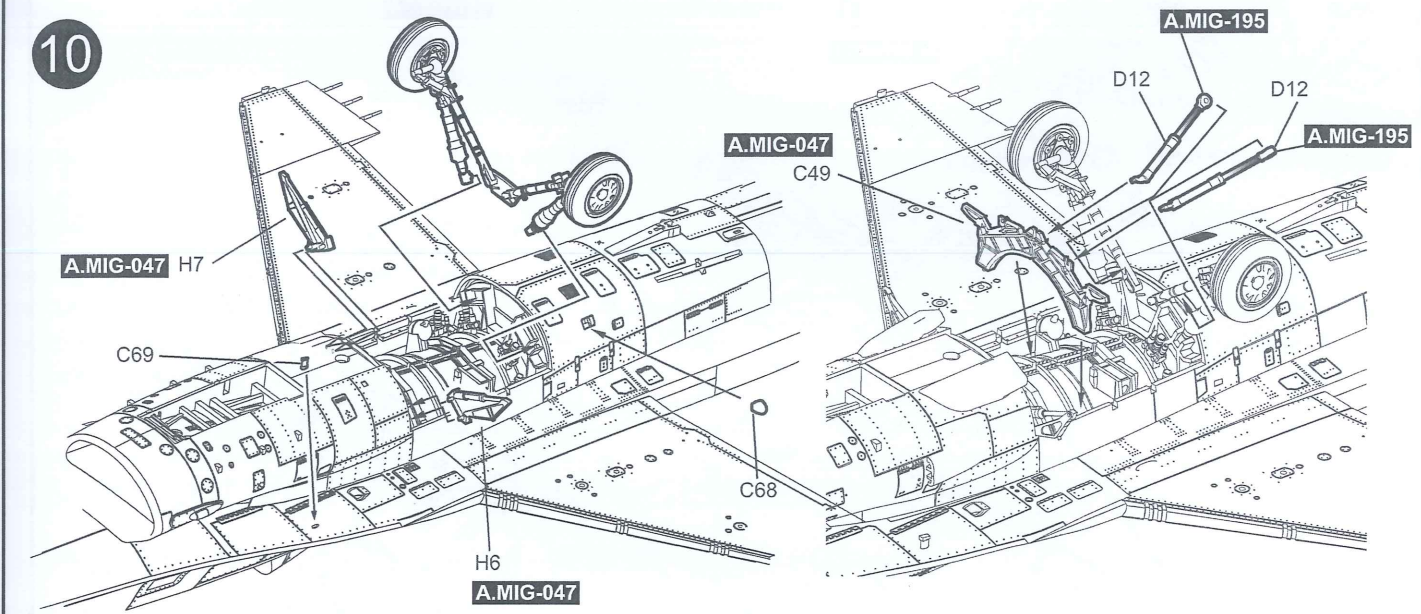

11

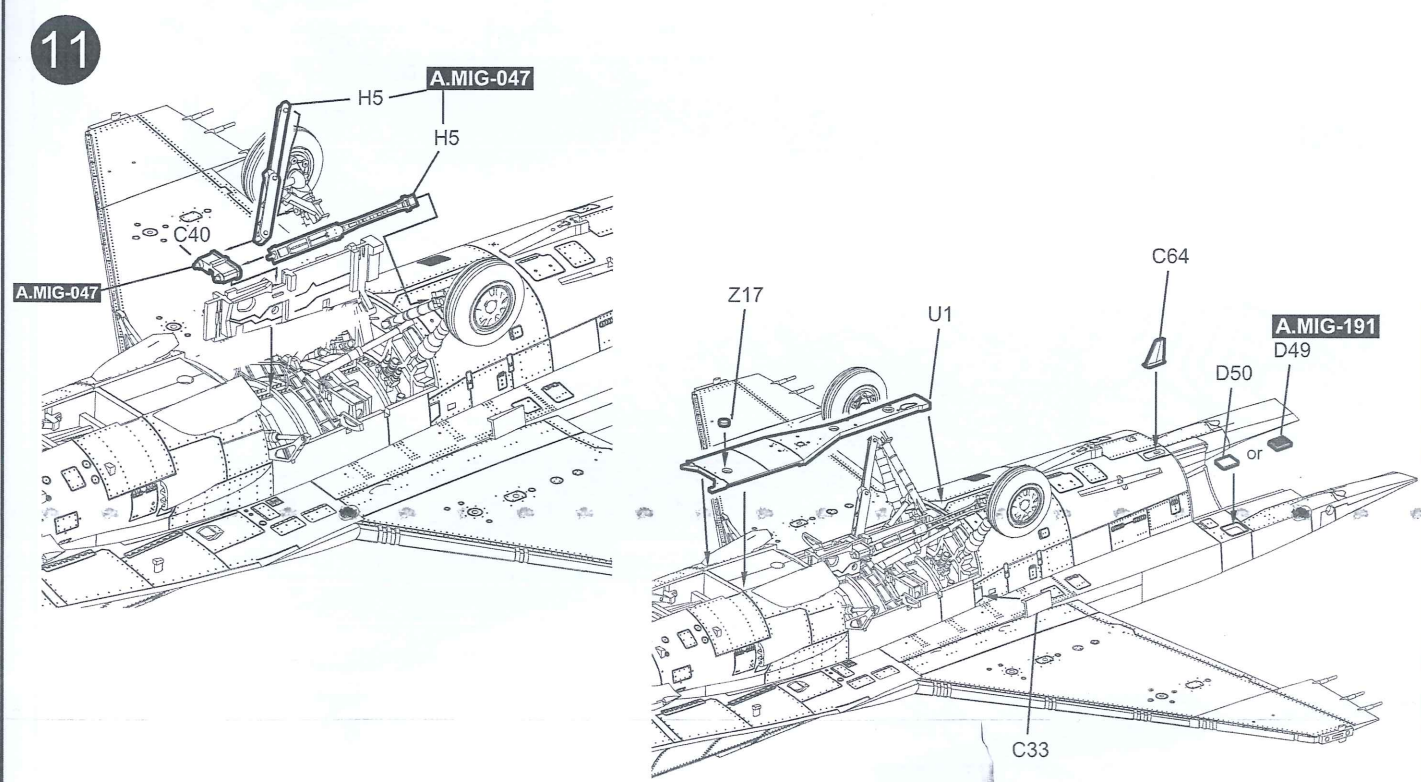

12

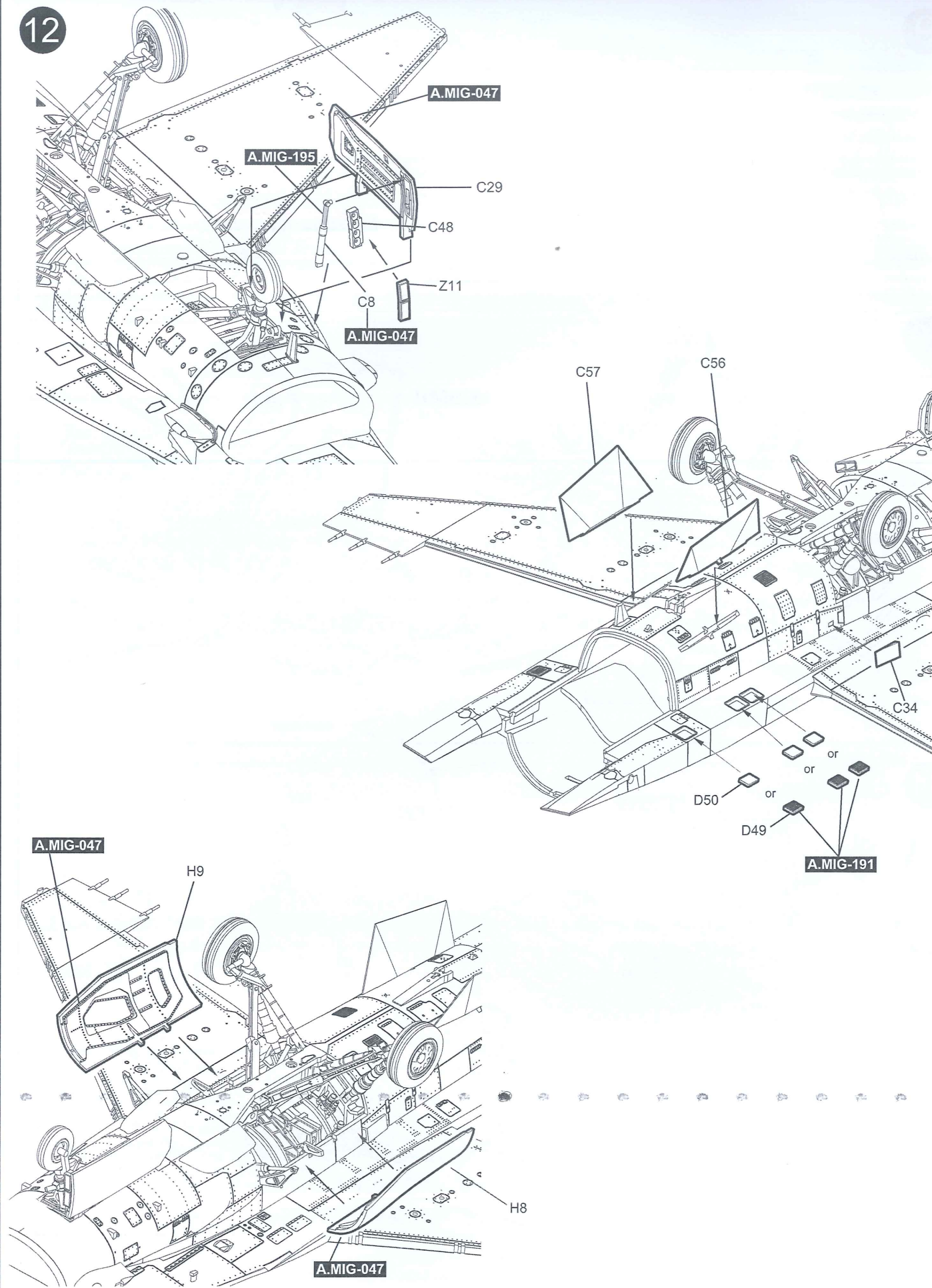

P20

13

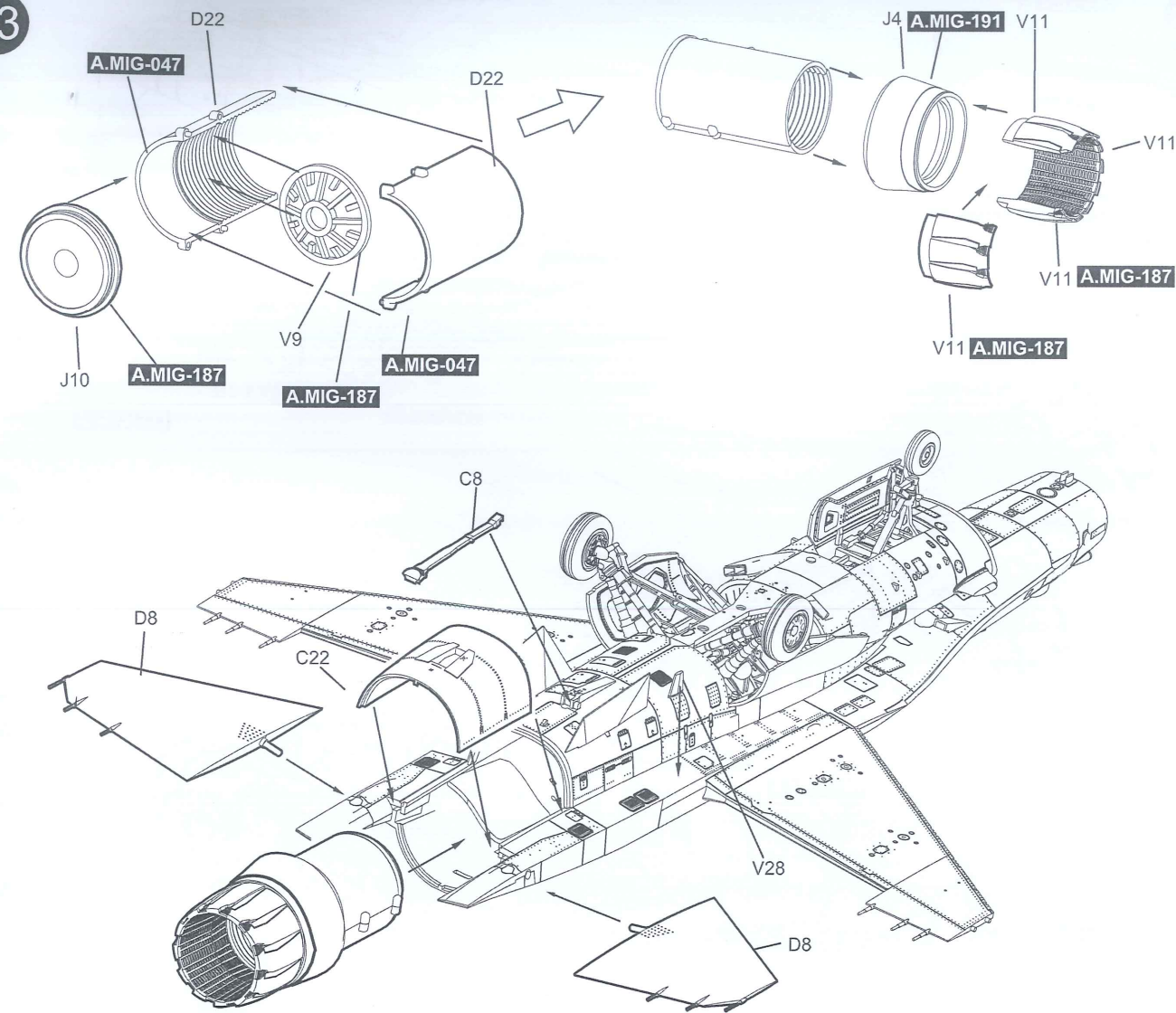

14

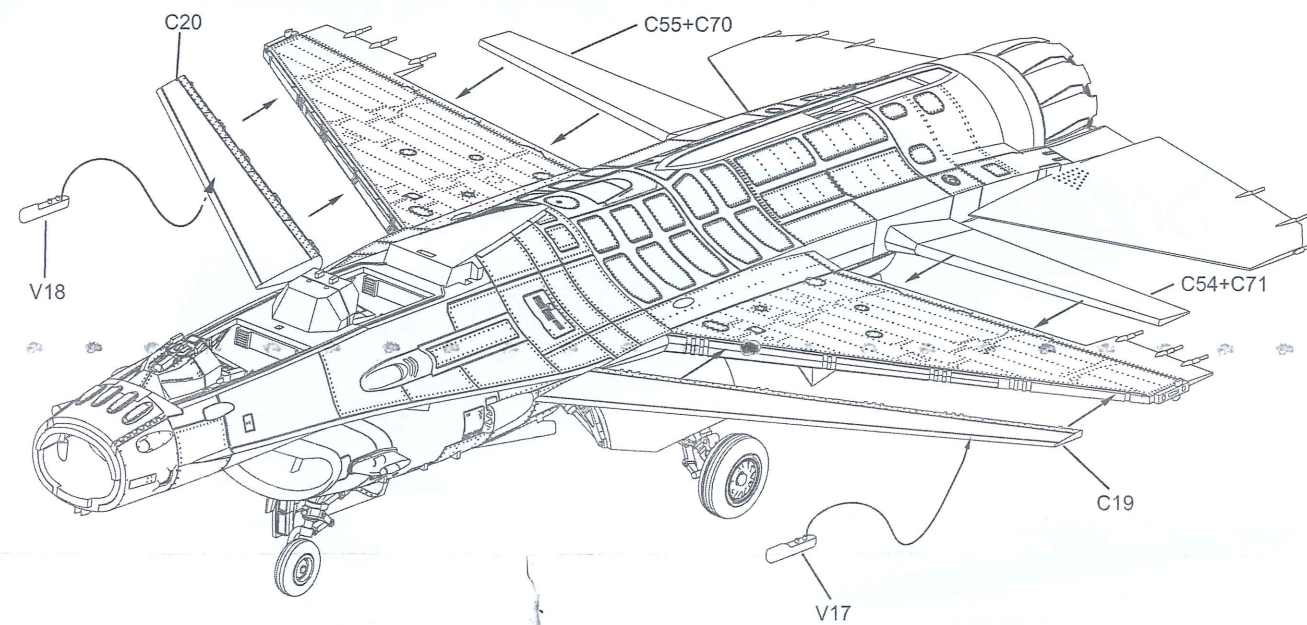

P21

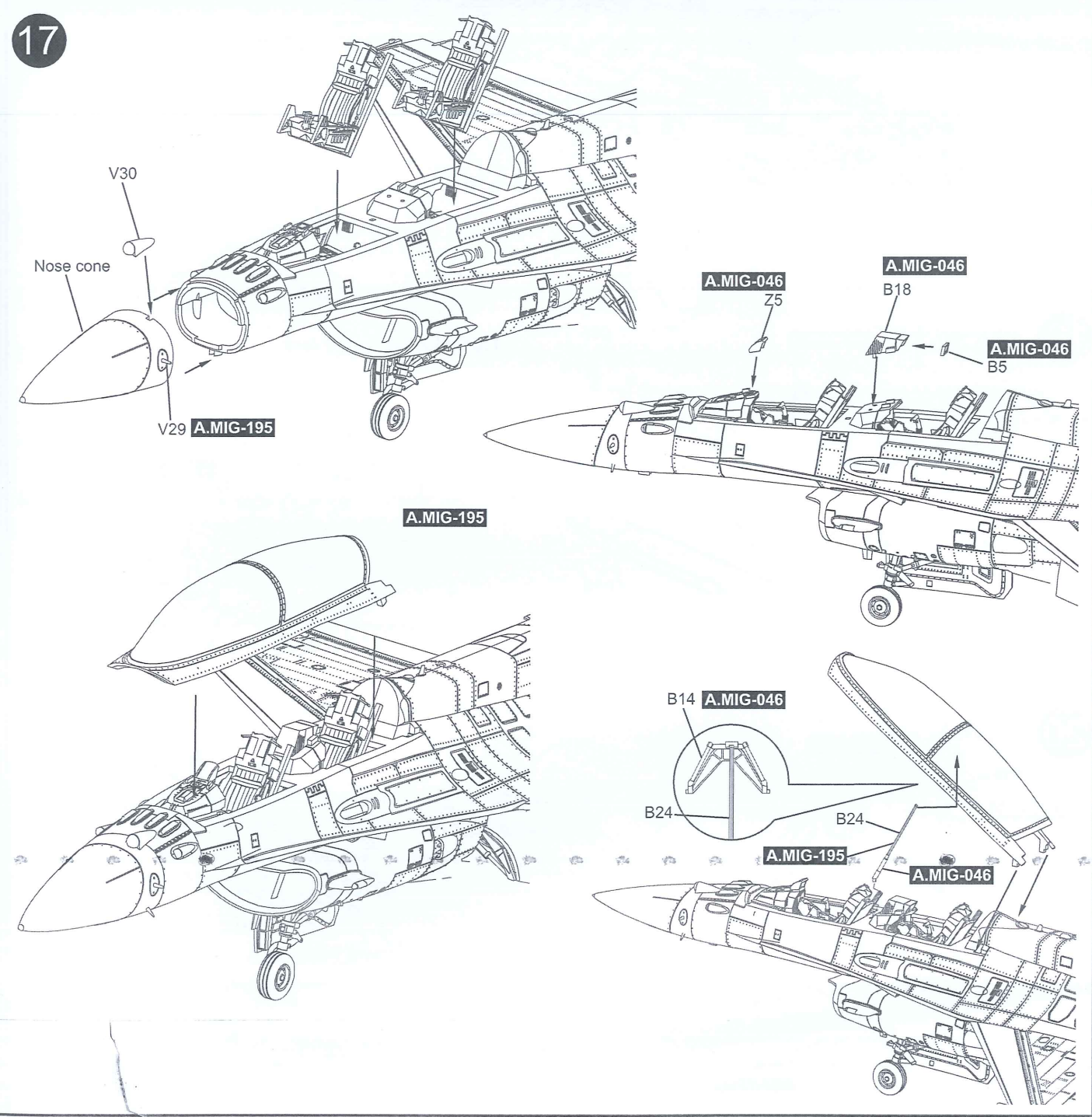
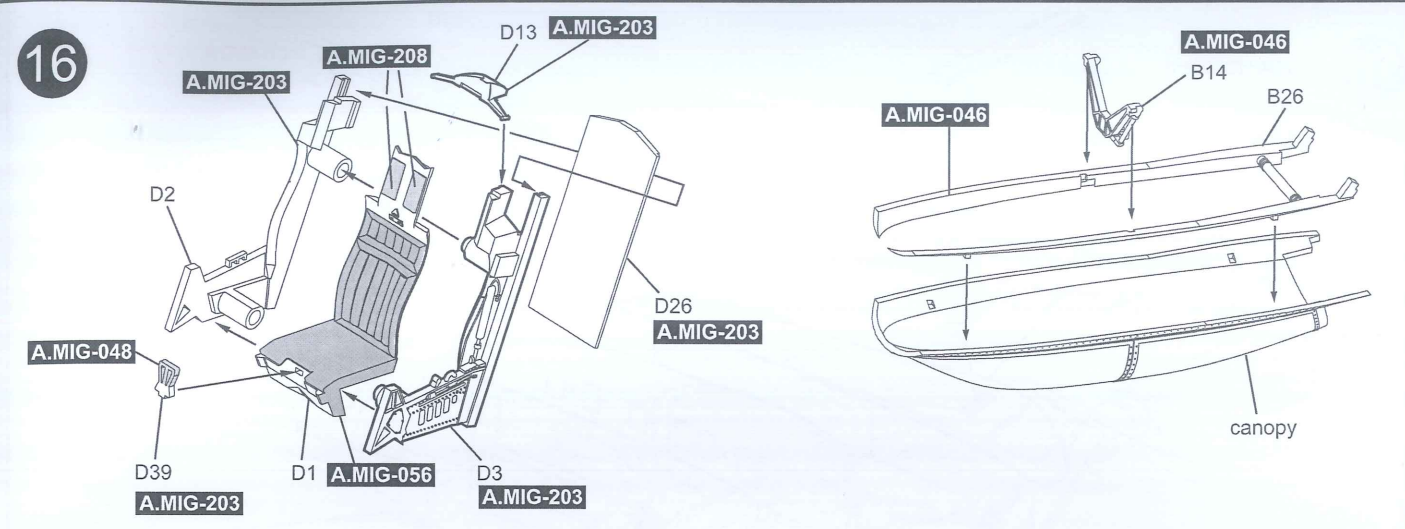
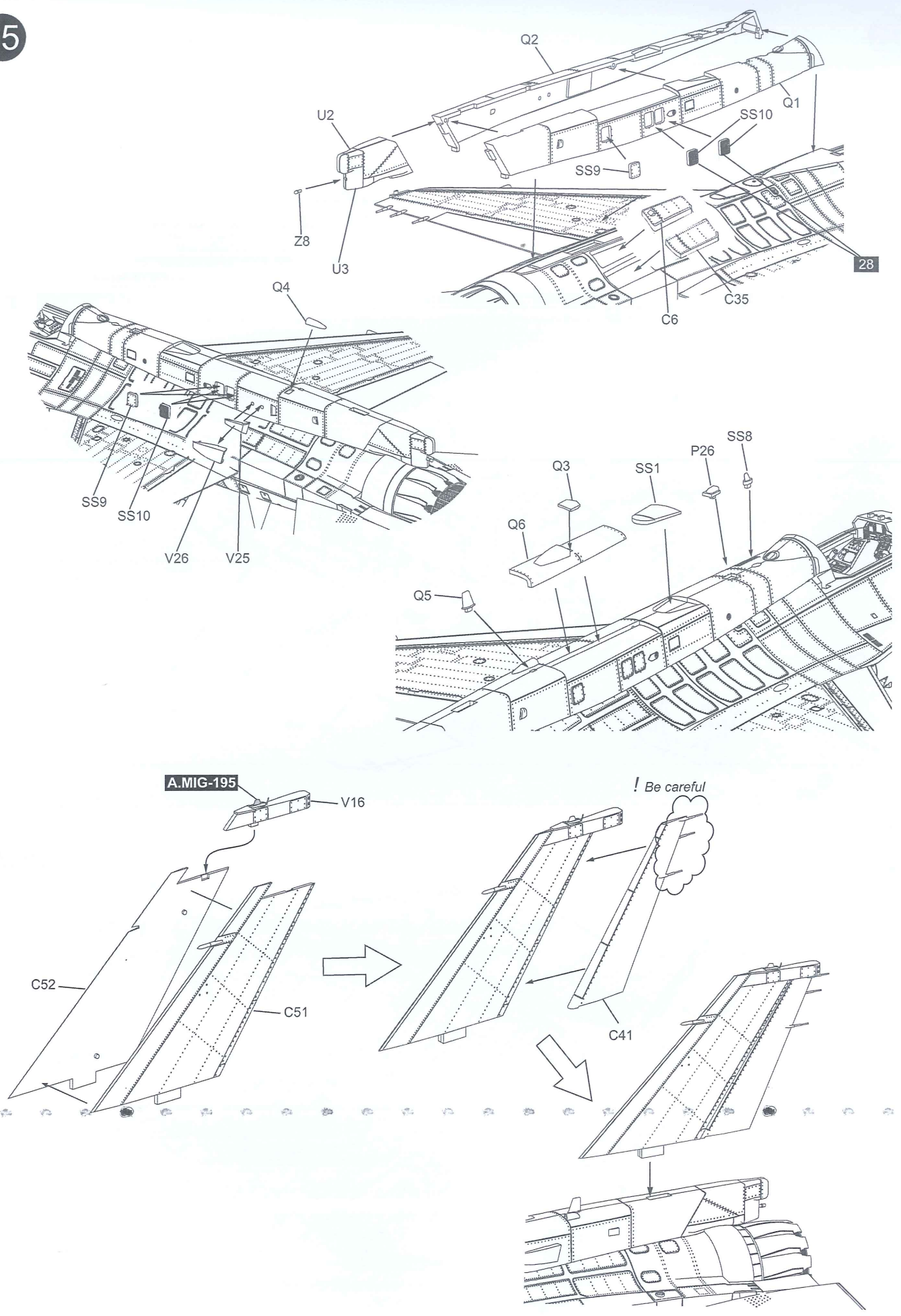

18 CFT Installation

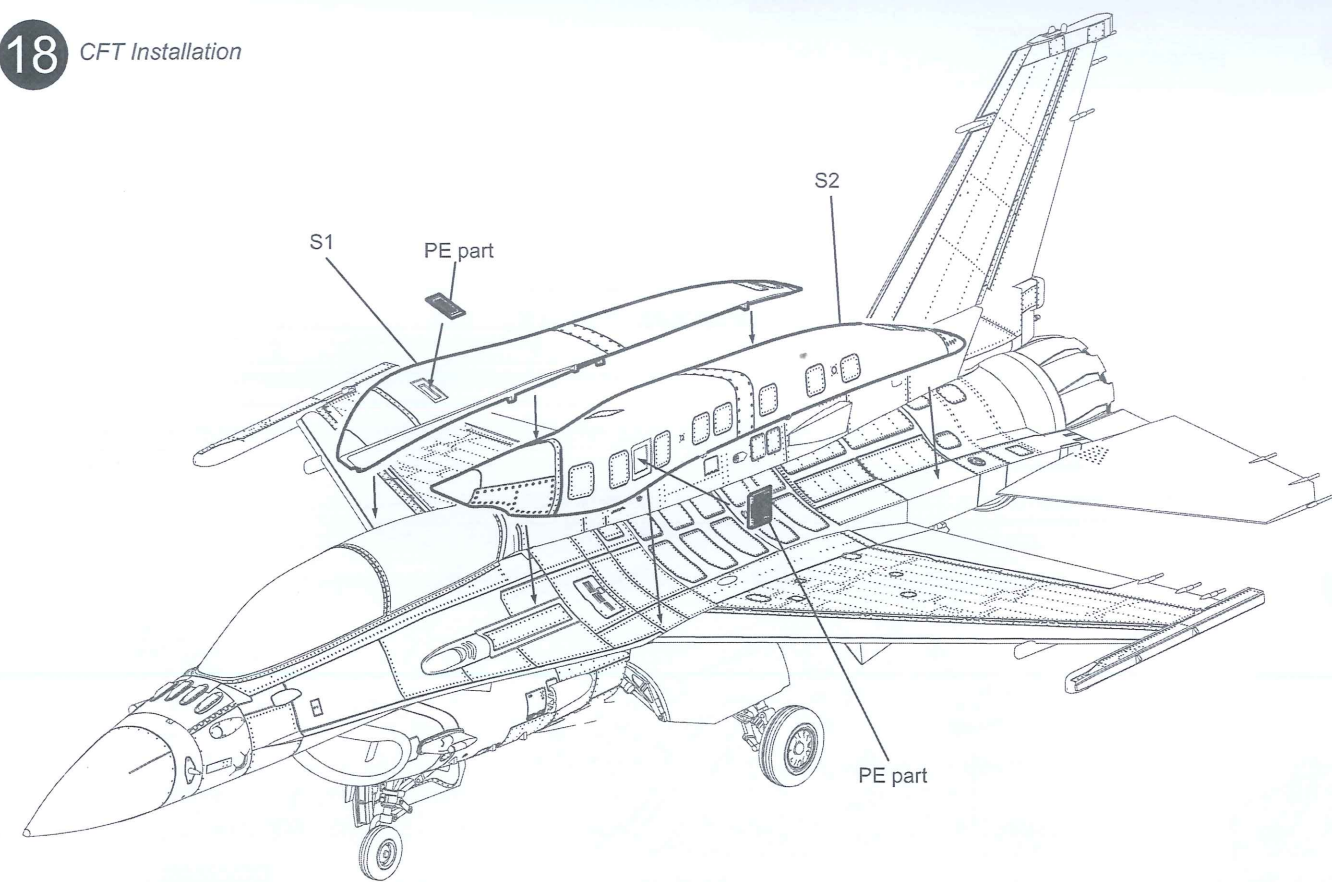

19 370 Gallon Wing Tank

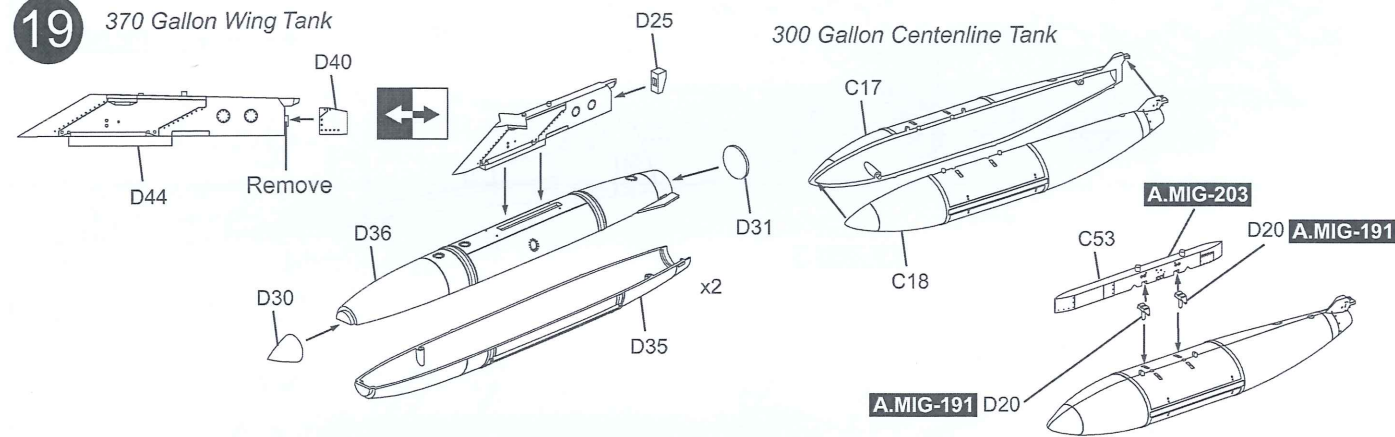

20

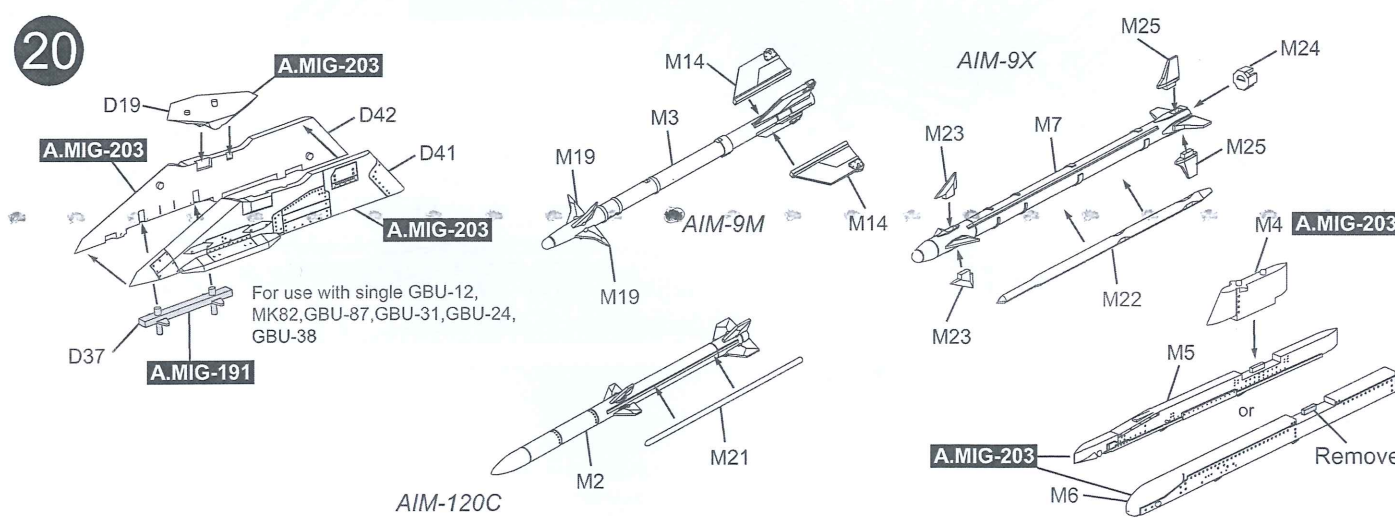

21

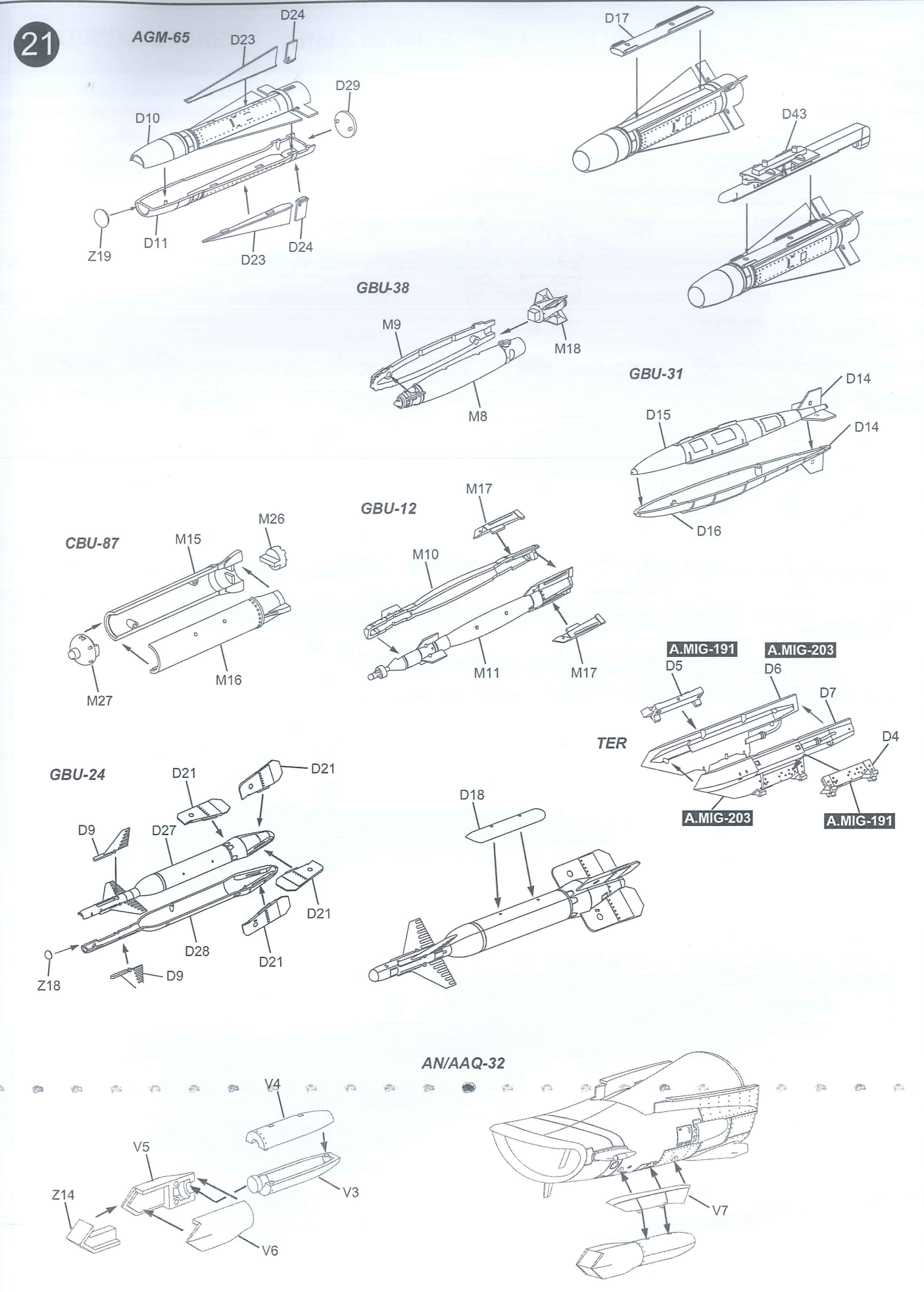

Painting & Decal Placement - External Stores

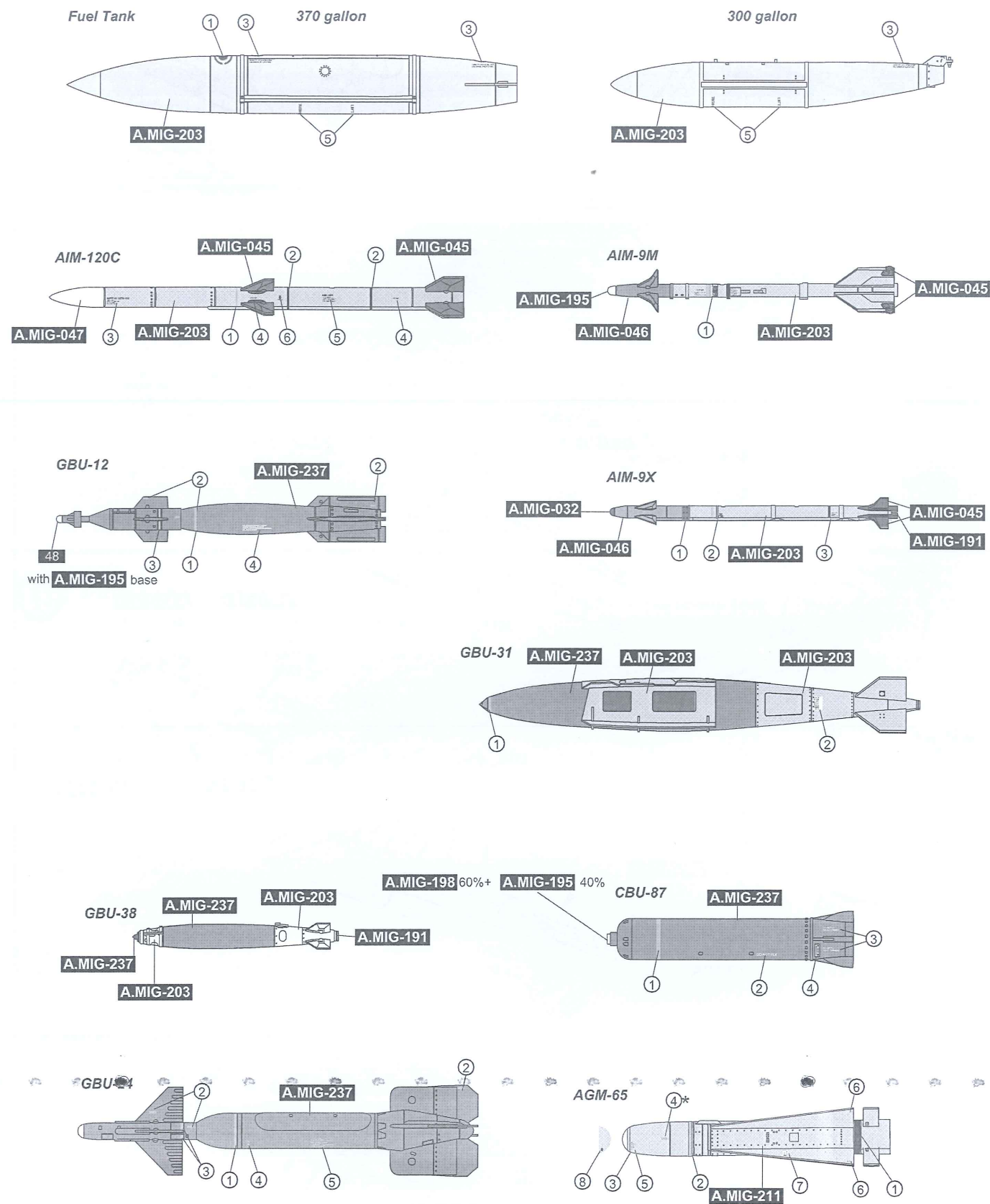

EXTERNAL STORES

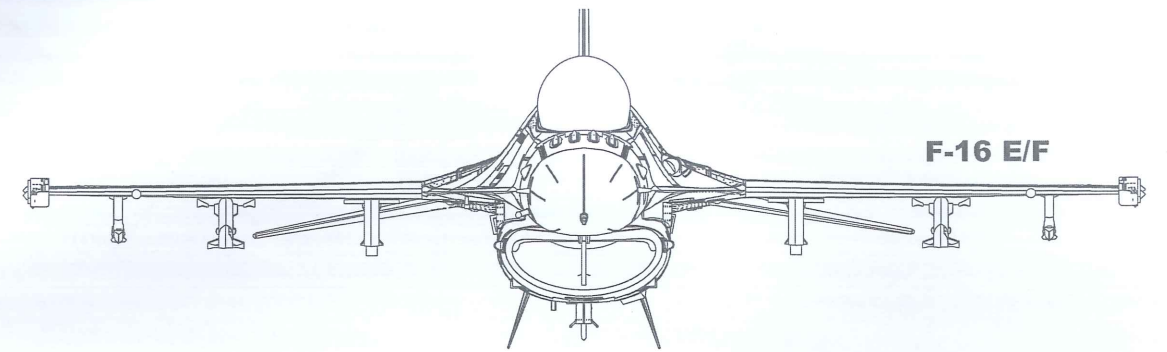

Station No. Weapons	9	8	7	6	5R	5	5L	4	3	2	1
LAU-114 (W/AIM-9M only)	●	●	●						●	●	●
LAU-129	●	●	●						●	●	●
AIM-9M	●	●	●						●	●	●
AIM-9X (W/LAU-129 only)	●	●								●	●
AIM-120B (W/LAU-129 only)	●	●	●						●	●	●
MK.82			●						●		
MK.82 (W/TER)			● ●						● ●		
GBU-12			●						●		
GBU-12 (W/TER)			● ●						● ●		
GBU-31			●						●		
GBU-87			●						●		
GBU-87 (W/TER)			● ●						● ●		
GBU-38			●						●		
GBU-38 (W/TER)			● ●						● ●		
GBU-24			●						●		
AGM-65			●						●		
370gal. Fuel tank				●				●			
300gal. Fuel tank						●					
AN/AAQ-32							●				

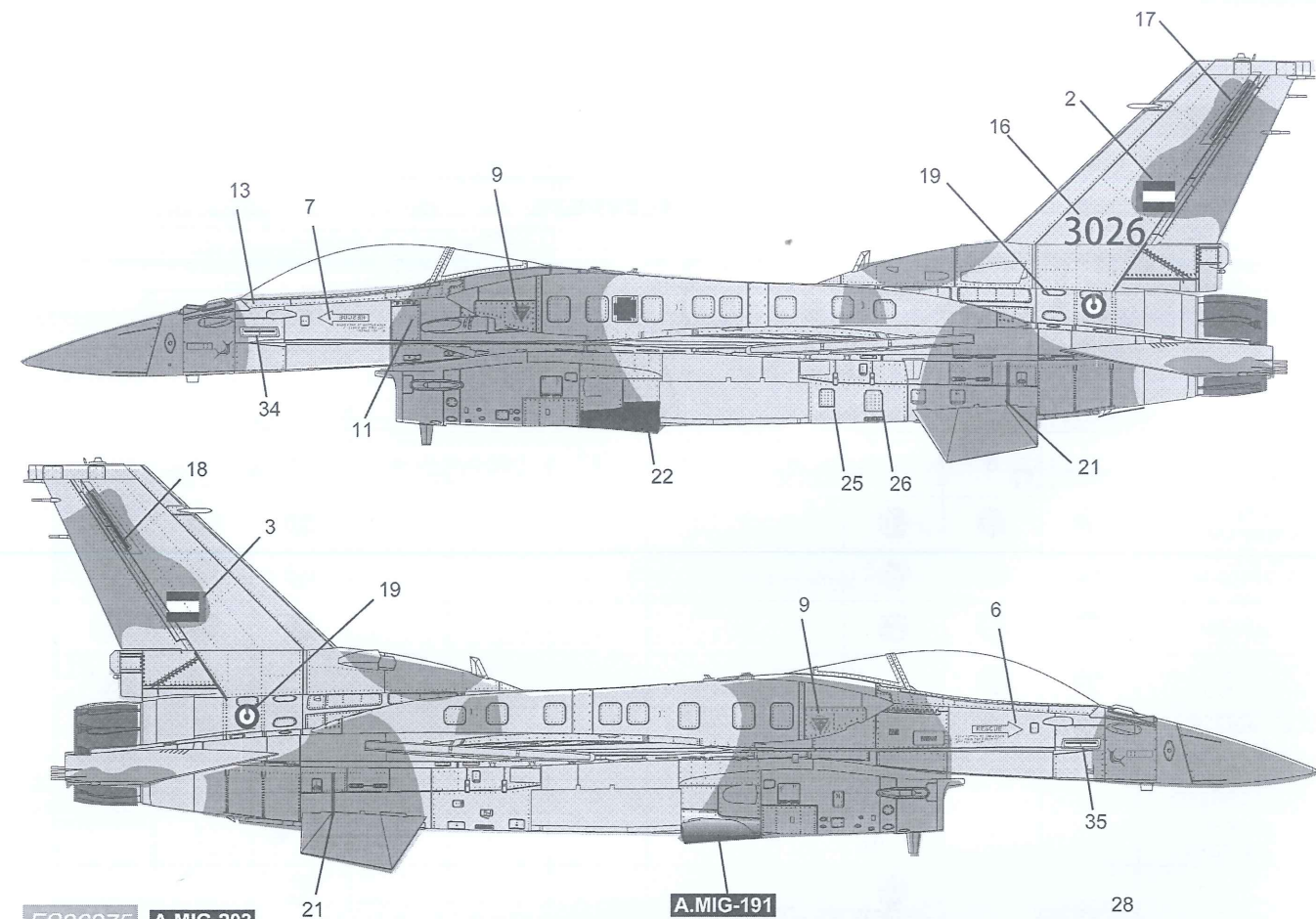

FS36375 A.MIG-203

FS36495 A.MIG-209

Steel A.MIG-191

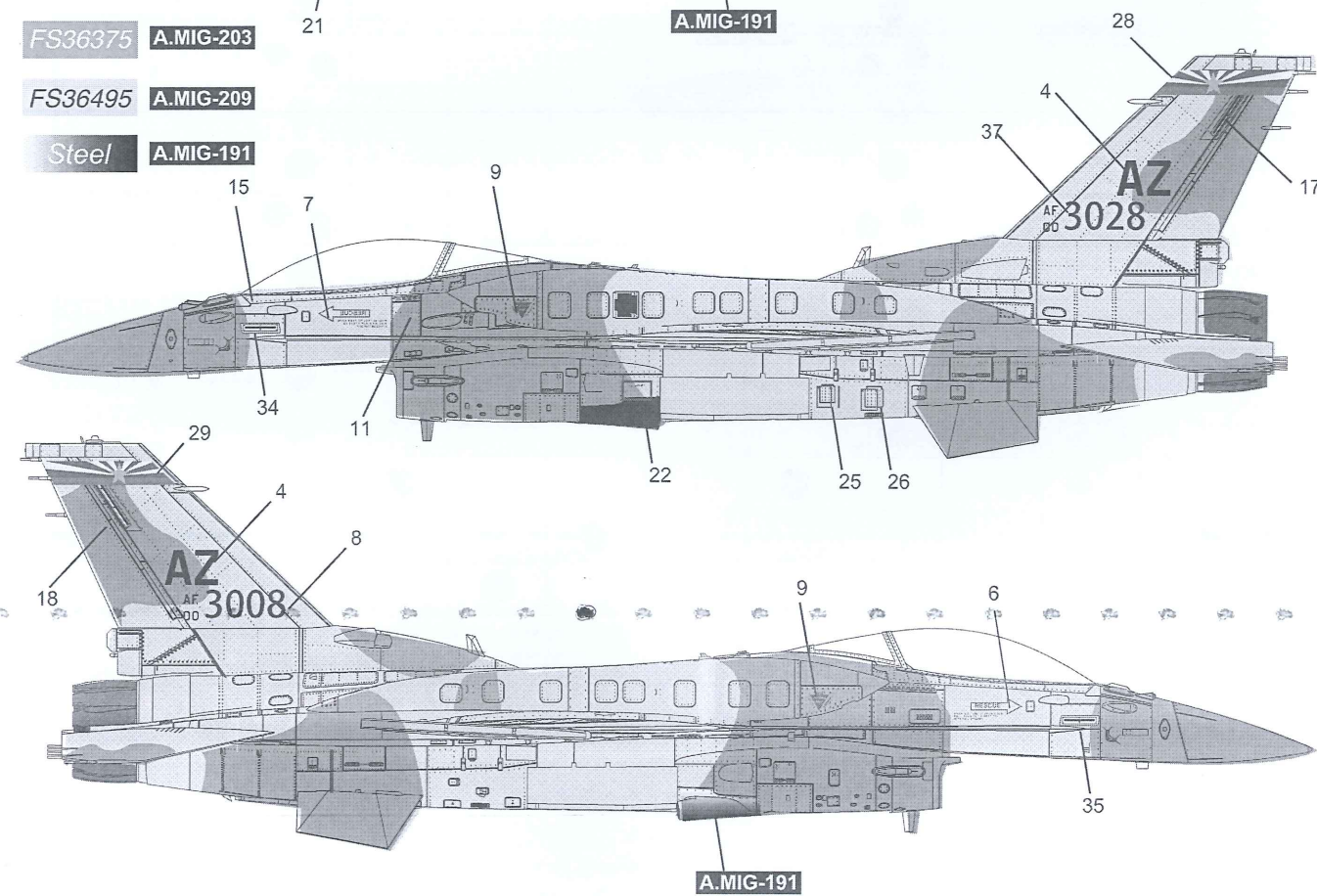

A.MIG-191

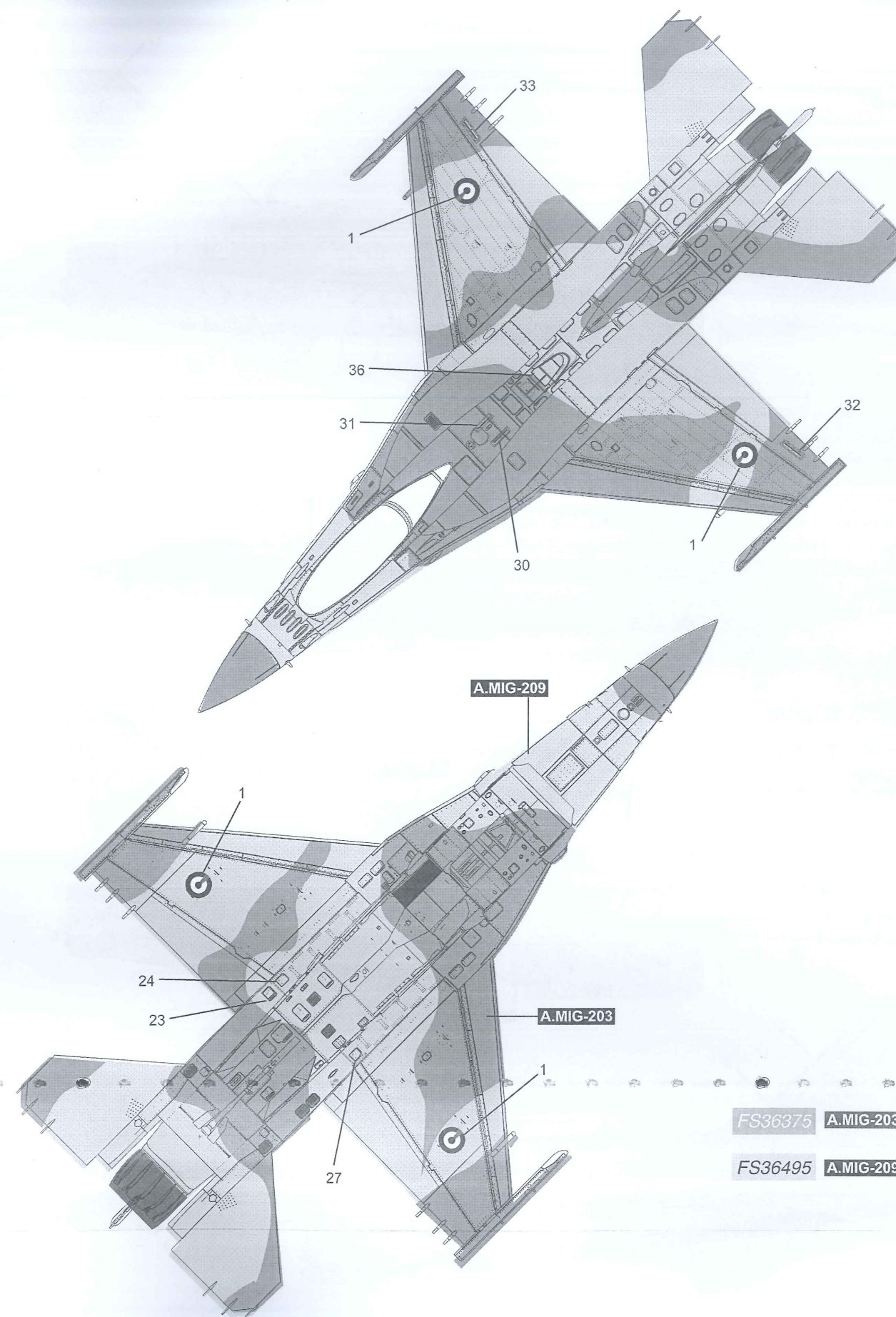

A.MIG-209

A.MIG-203

FS36375 A.MIG-203

FS36495 A.MIG-209

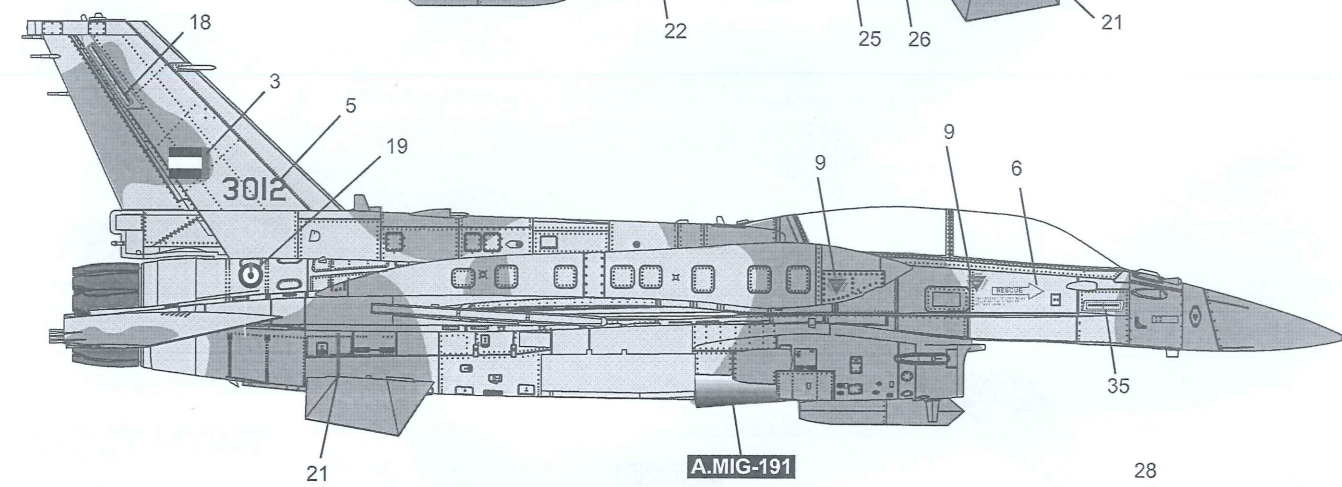
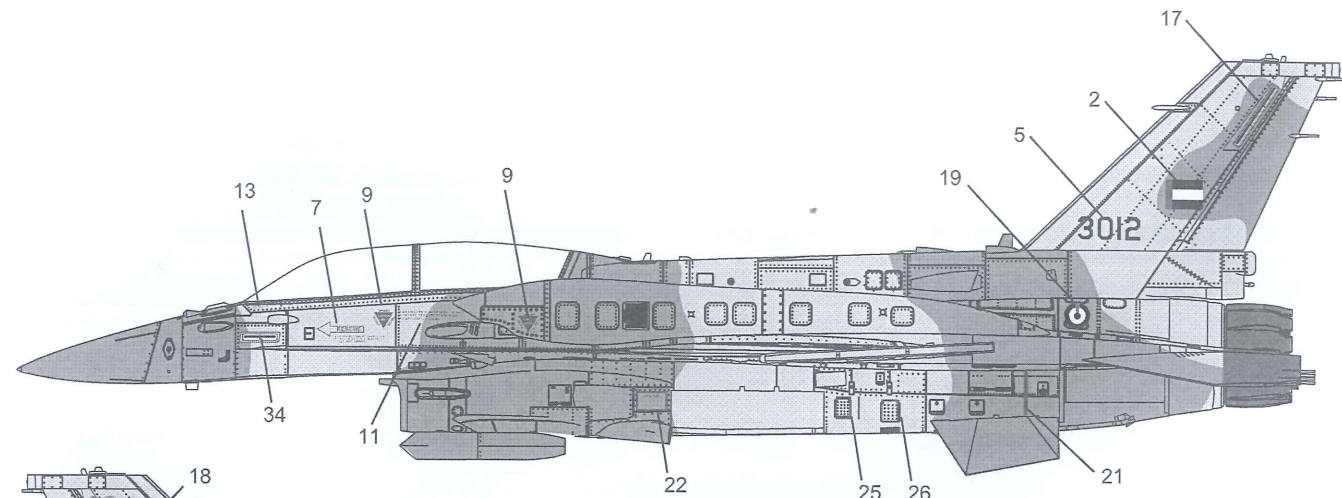

A.MIG-191

FS36375 A.MIG-203

FS36495 A.MIG-209

Steel A.MIG-191

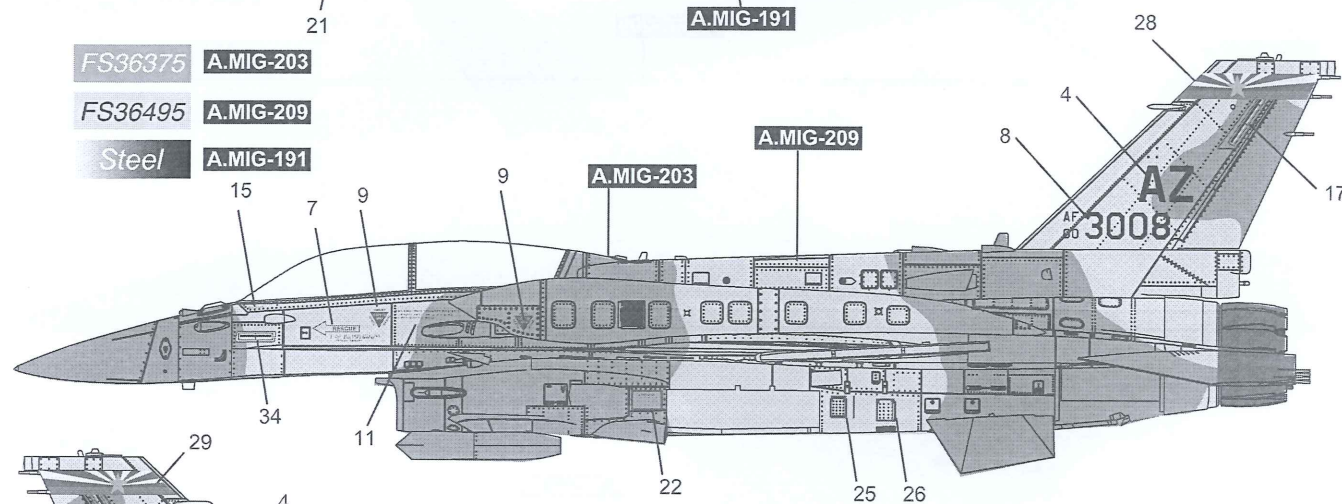

A.MIG-209

A.MIG-203

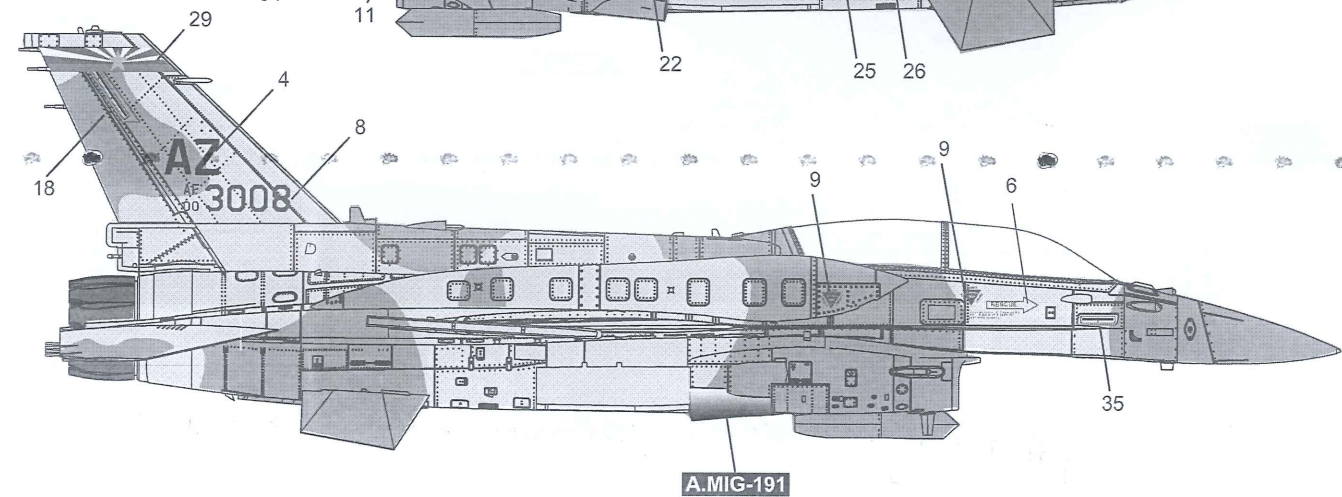

A.MIG-191

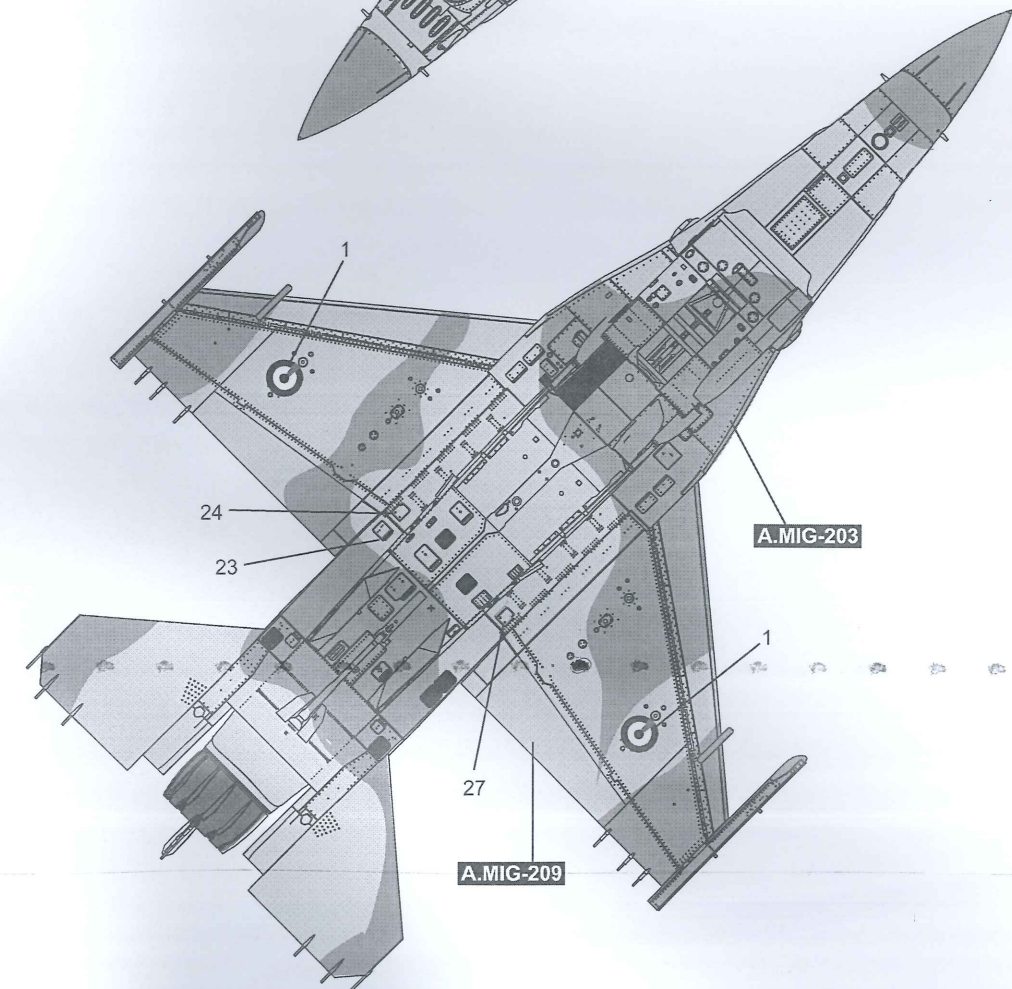
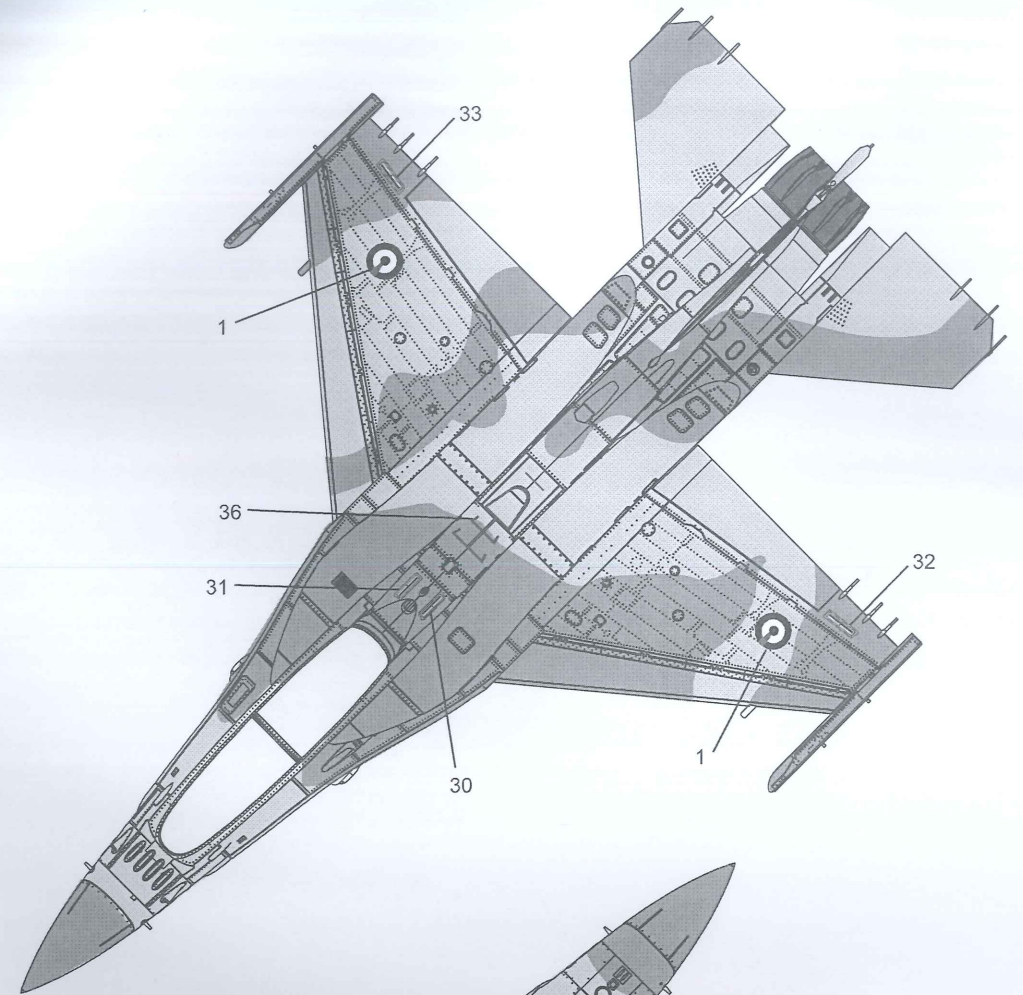

A.MIG-203

A.MIG-209

FS36375 A.MIG-203

FS36495 A.MIG-209