

1/35 Scale
35A05

Precision
Pro Edition
精密專業版



6 (Axle) 80t SSyms

GERMAN RAILWAY
德國六軸80噸軌道重型平板運輸車

SCHWERER PLATTFORMWAGEN
ドイツトラック80トン大型平置き運搬車SSymsタイプ 精密プロフェッショナルバージョン

Special thanks to Nick Tebbs and Nacho Roces
for their technical support and assistance

USER MANUAL 产品制作手册

Warning 特别注意

Please read the following before assembly 制作前请仔细阅读以下事项

1. This product is the parts of the unassembled precision models. It requires special tools to assemble and paint the model. Glue, paint or tools are not included.
 2. This product is for children of 14 and up, younger children should be under adult supervision. For those who will make the model and caregivers, please read manual carefully to understand the procedures.
 3. Please be careful when using special model scissors, pencil sharpener or special dedicated file to remove the excess plastic materials on the surface. Do not damage or lose.
 4. Please use special adhesive to assemble model parts. Please use power glue for metal parts carefully since it might cause be too powerful for the parts.
 5. Please read the notes before using glue, painting or decal.
1. 本产品为未组装的比例模型套装零件，需要使用模型专用制作工具自行组装和上色。本产品内不含粘合剂，涂漆和工具。
 2. 本产品适合14岁以上儿童和成年模型爱好者，低年龄者请在成人监管看护下制作。制作者和看护者请仔细阅读本制作手册，了解基本制作流程和注意要点。
 3. 请小心使用模型专用剪，专用笔刀或专用锉刀去除零件表面多余注塑胶料，不要损坏或丢失。
 4. 请使用模型专用粘合剂粘合零件组装。金属零件粘合请小心使用强力胶，过量强力胶使用可能导致可动零件完全粘合。
 5. 使用粘合剂，涂漆和水贴之前请阅读相关注意事项。

- ▲ Do not use glue or paint near the fire, please keep good air circulation.
- ▲ Please be careful with the tips of both tools and parts. Please pay special attention to photo-etch parts to avoid scratch or injury.
- ▲ Please keep away from children, pets or anyone who need special care. Avoid any possible injury from small parts and tools. please keep plastic bags away from children or pets.
- ▲ 切勿在近火处使用胶水或涂漆，请保持制作环境的空气流通。
- ▲ 请小心制作工具和产品零件的尖端，处理蚀刻片时请特别注意，防止划伤，避免伤害。
- ▲ 制作时请远离儿童、宠物和需受监护的人员，避免细小零件和工具对其造成损伤。请将产品中的包装塑胶袋远离儿童和宠物避免发生窒息危险！

14+ Kit suitable for ages 14 to adult
本产品适合14岁以上青少年及成人收藏者

Make 2 Pcs 制作二组	Optional 选择模式	Remove / Cut 切割	Bend 弯曲	Apply Decal 贴水印纸	Choose make or not 选择是否制作
Open Hole 钻孔	Caution 小心注意	Do Not Cement 无需粘合	Fill Hole 填平	Polish 打磨	Instant Glue For Metal 用强力胶

A x2

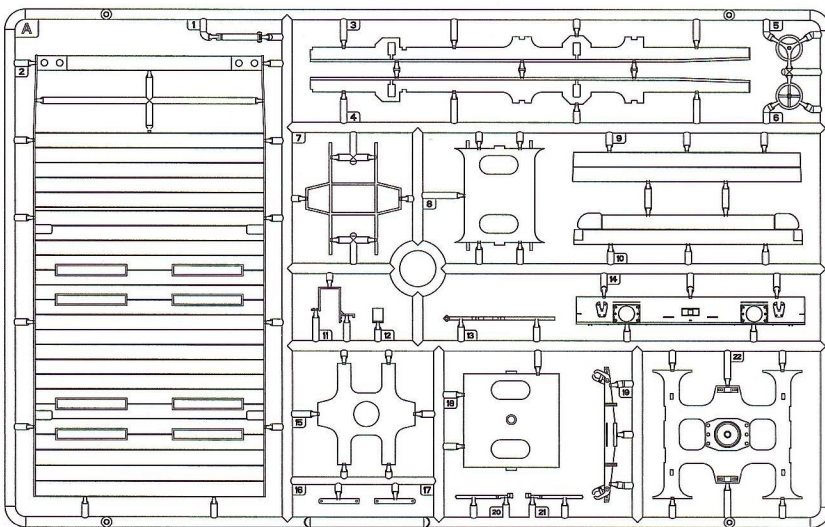

Y1 x6

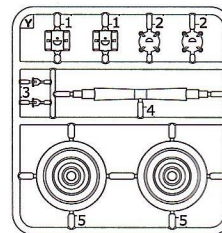

Y2 x2

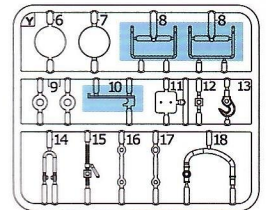

C x1

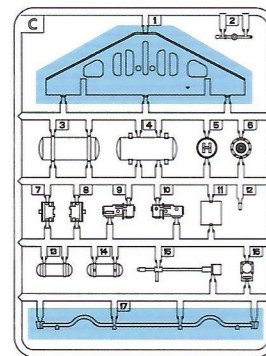

Parts not for use
不需要的零件

Wooden wheel stopper
木质止退器 (x8)



Rubber brake hose
橡胶软管 (70 mm x2)



Photo-etched Parts
蚀刻片 (x1)

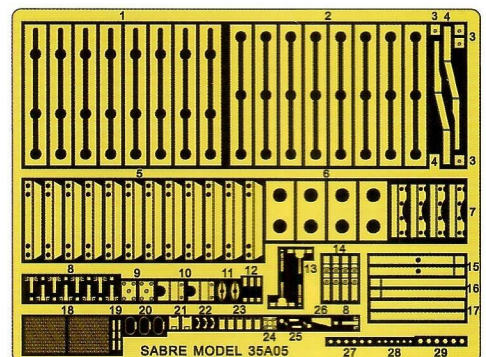

B x4

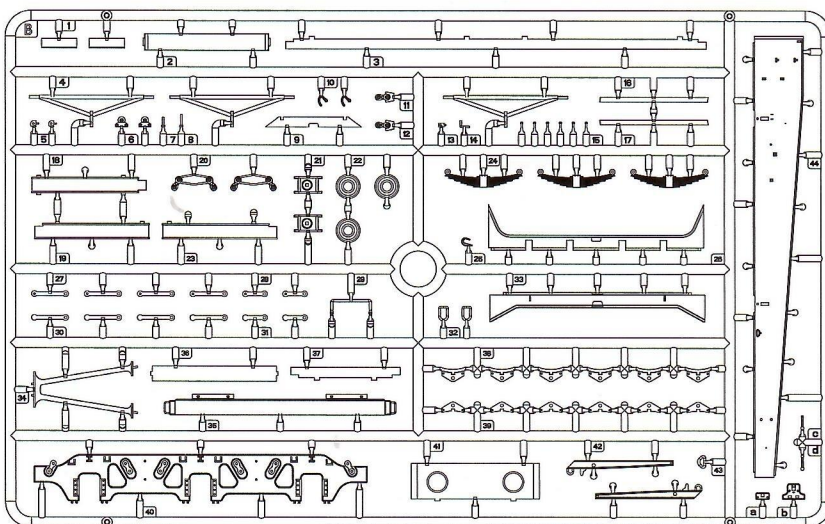

Metal cable 金属线缆 (1000 mm x1)



1

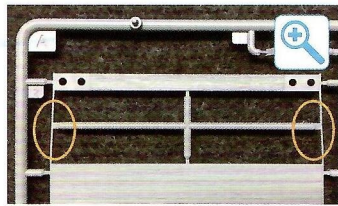

Be careful to break when cutting A2
剪切A2时请小心断裂



Polish cross-section
截面打磨平整

B37(x4)

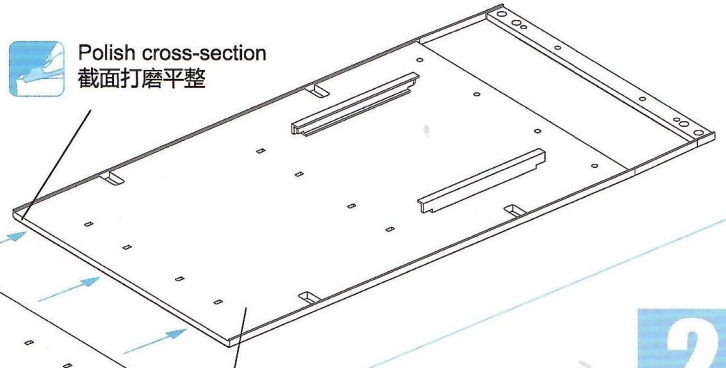

A2

2

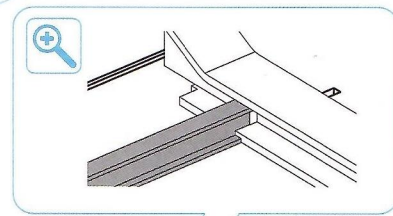

A8(x2)

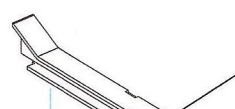

B33

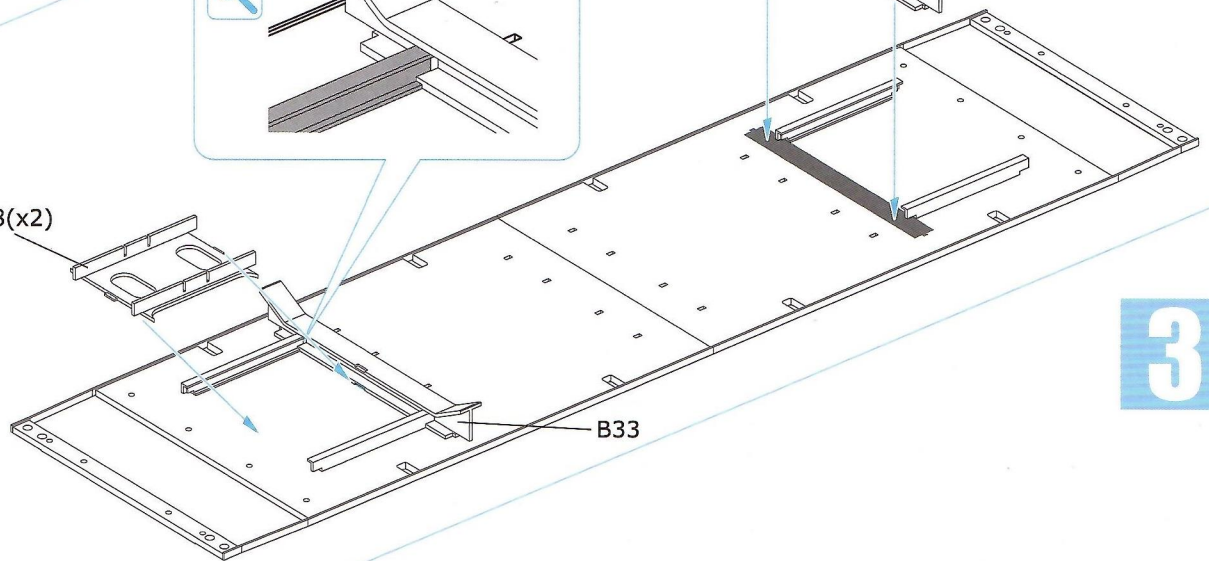

B33

3



Little polished cross section to maintain horizontal assembly
两端截面适当打磨，保持水平装配

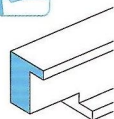

B3

B9(x4)

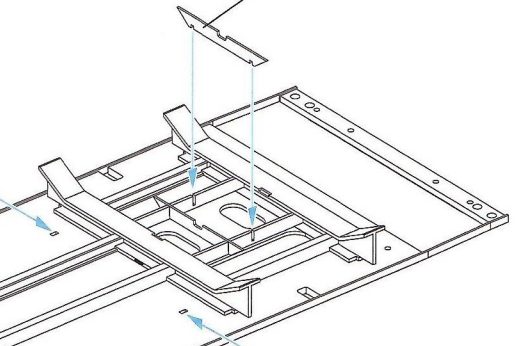

B33(x2)

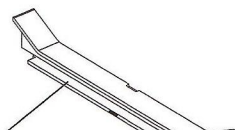

B3

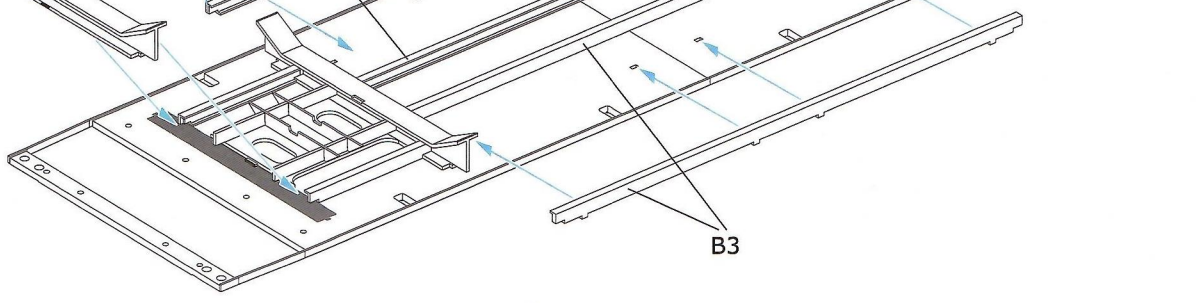

4

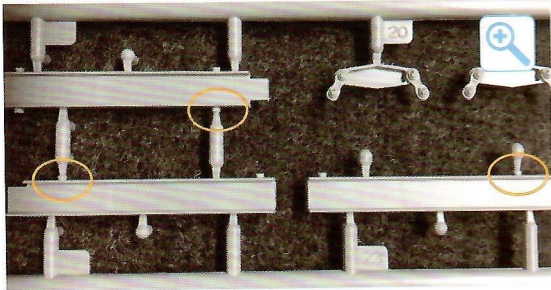

Attention when cutting
剪切时请注意定位口

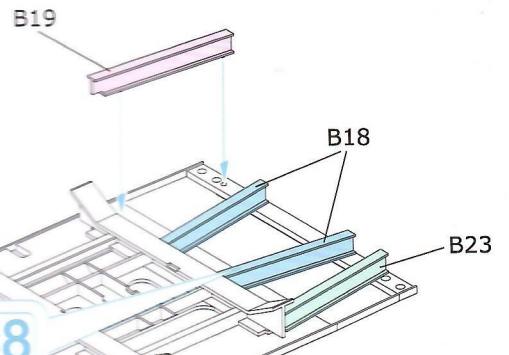
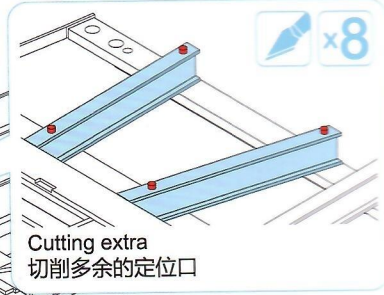
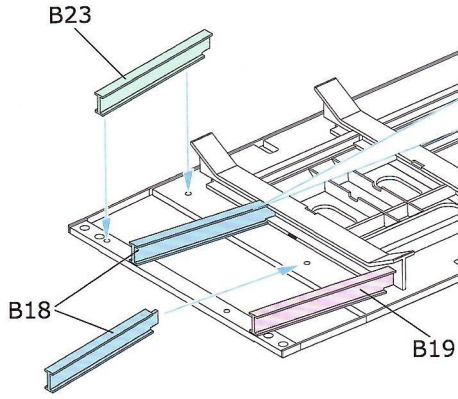

5

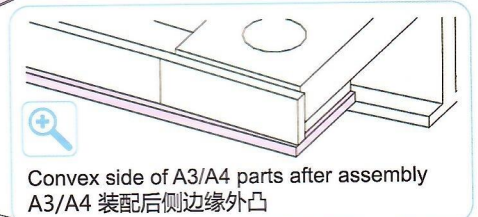
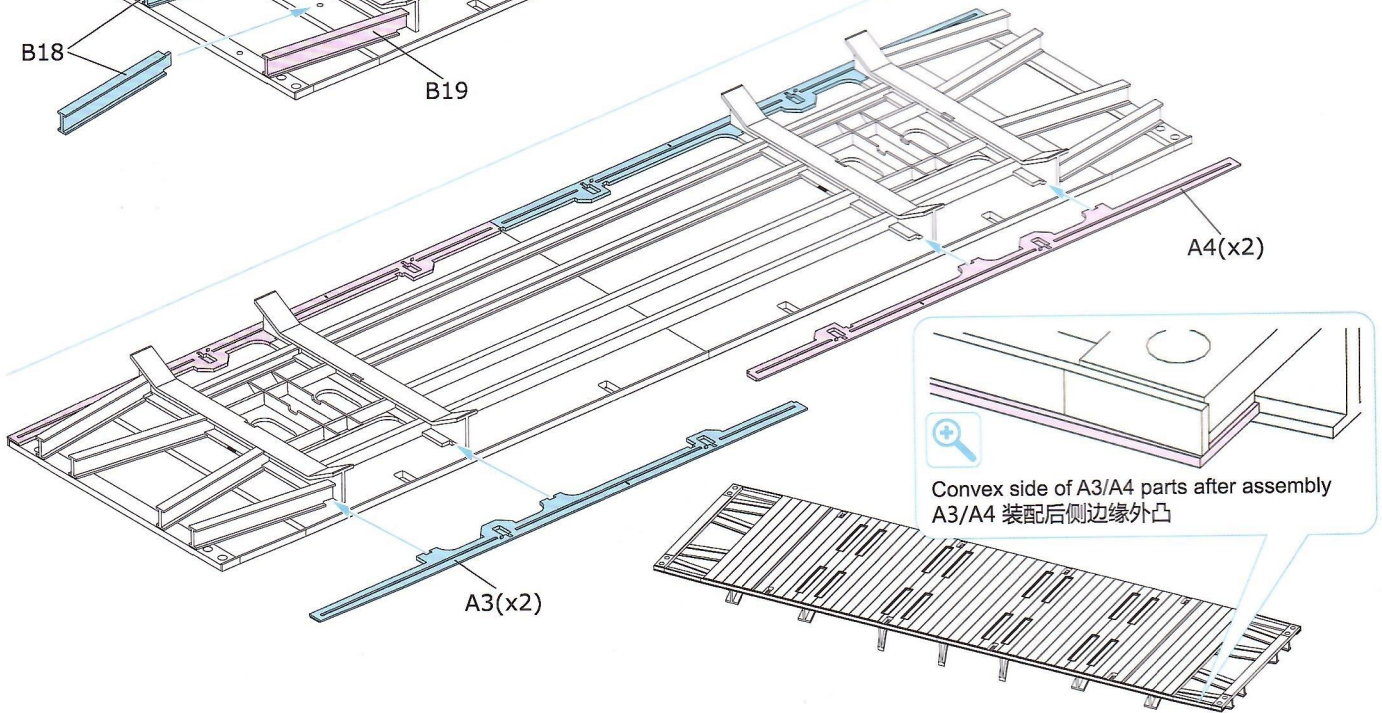

6

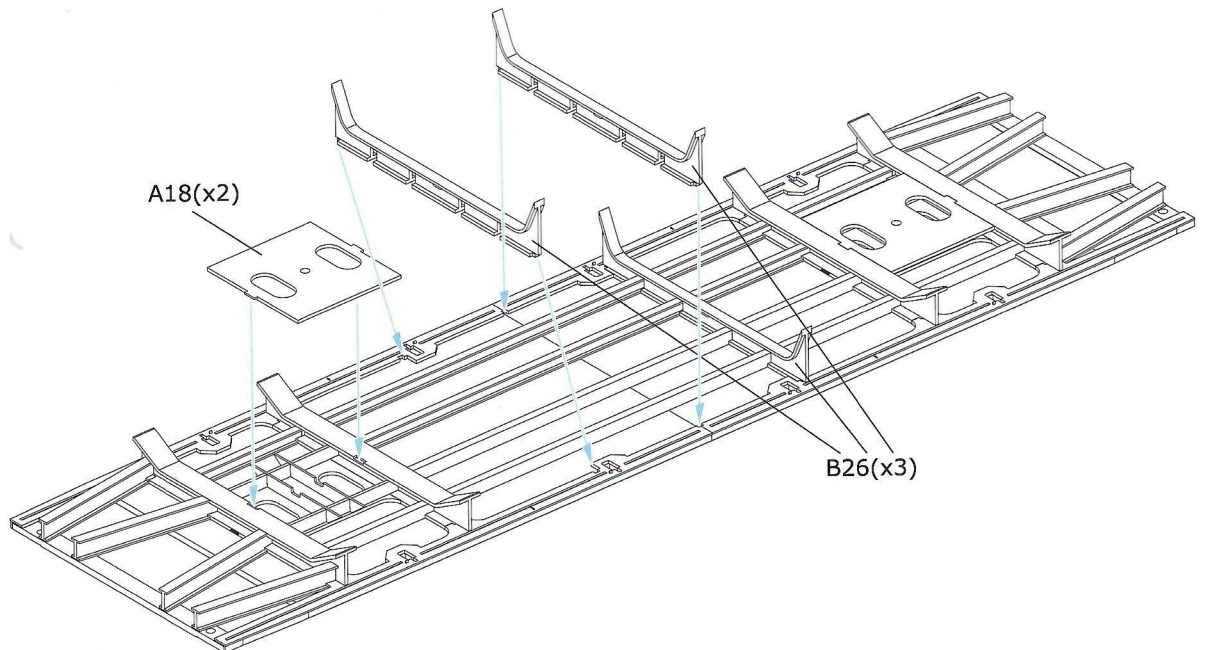

7

B44(x4)

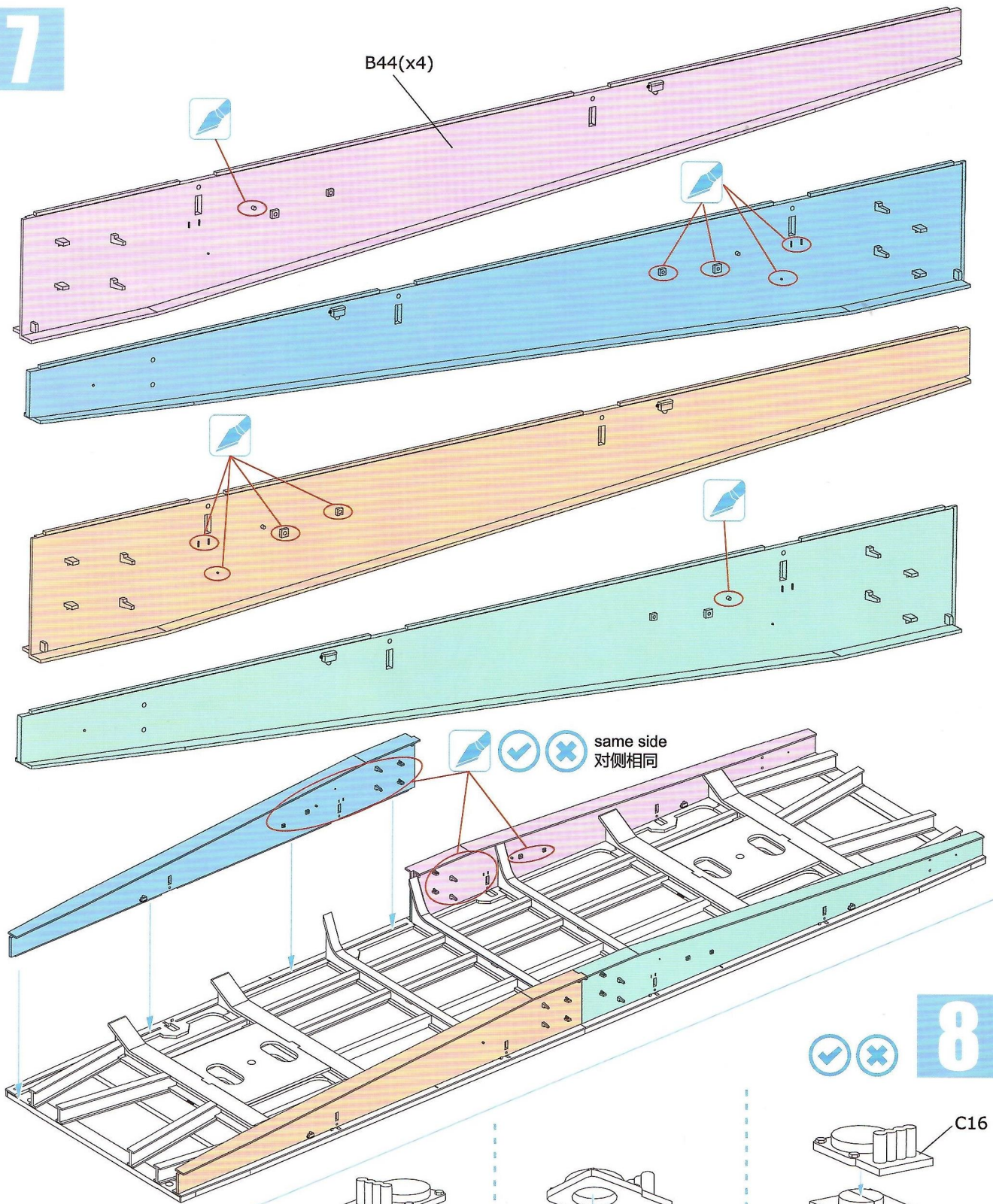

8

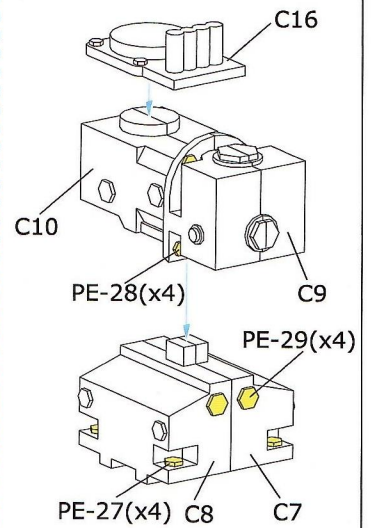
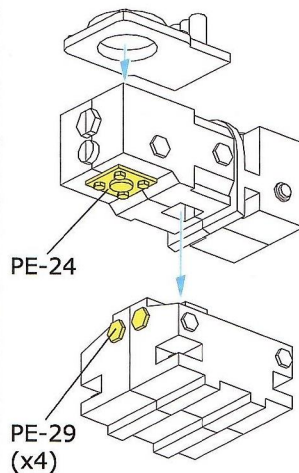
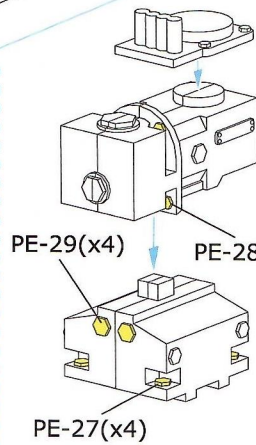
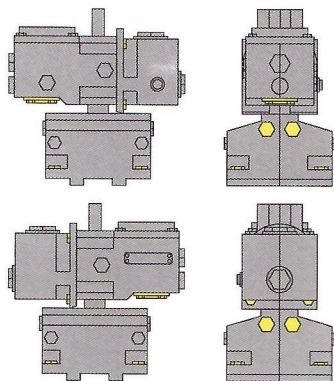

9

Handrail folding status
扶手折叠状态



A Without handrail status
无扶手状态

B

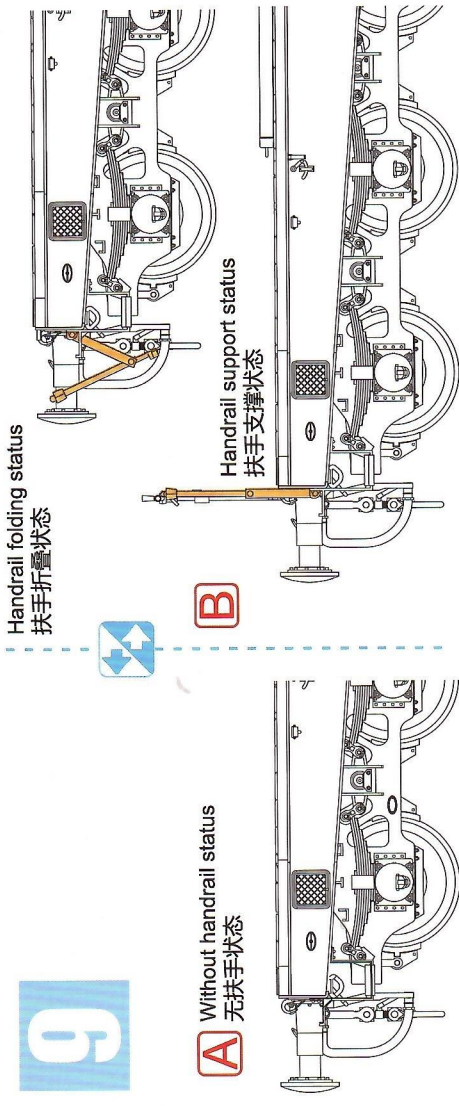

8

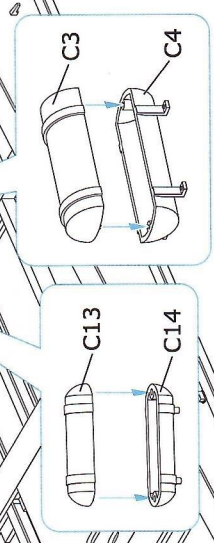
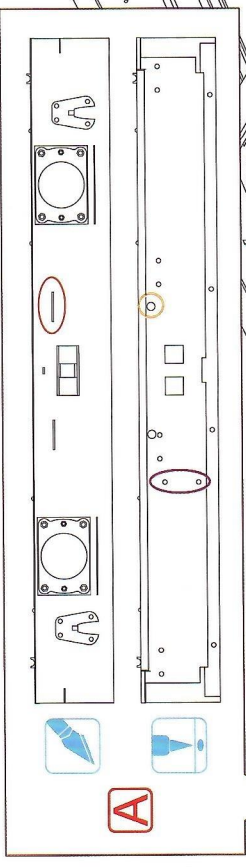
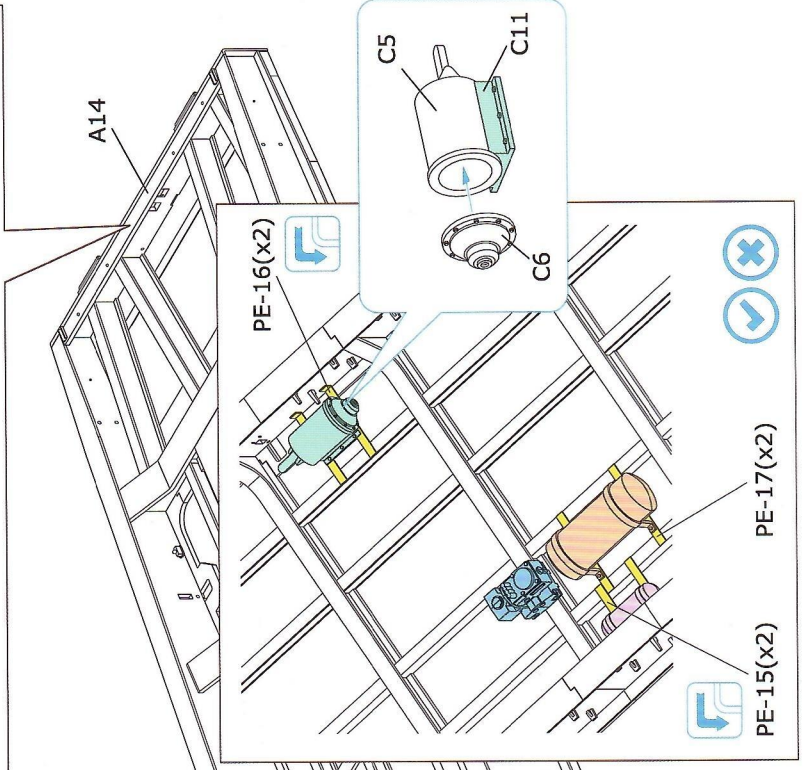
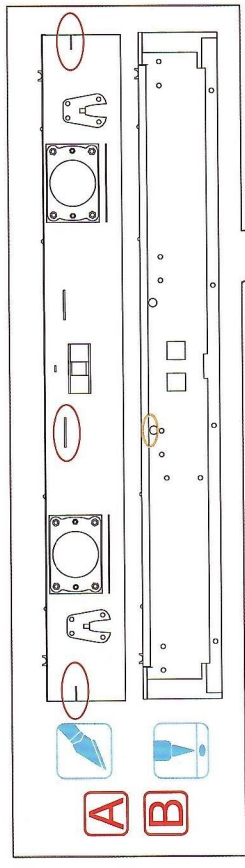

A

A14

Use following drill
请使用以下规格钻头

- 0.8mm
- 0.6mm
- 0.5mm

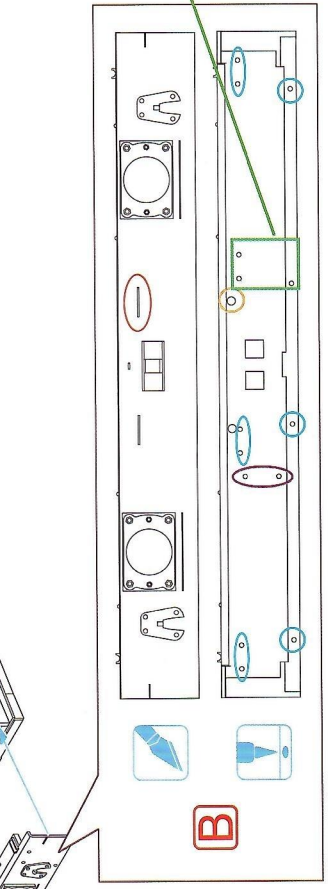

B

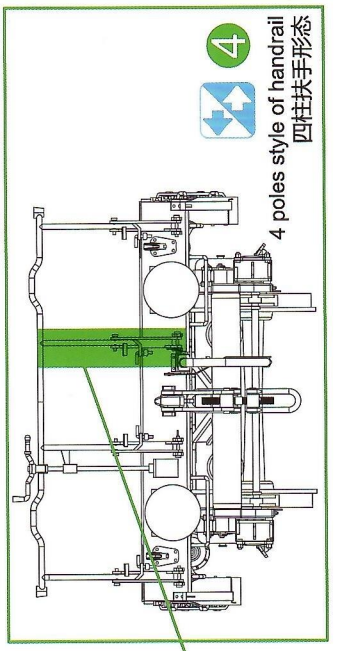

4



4 poles style of handrail
四柱扶手形态

10

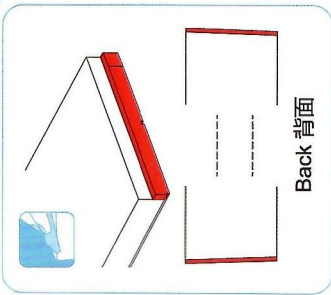
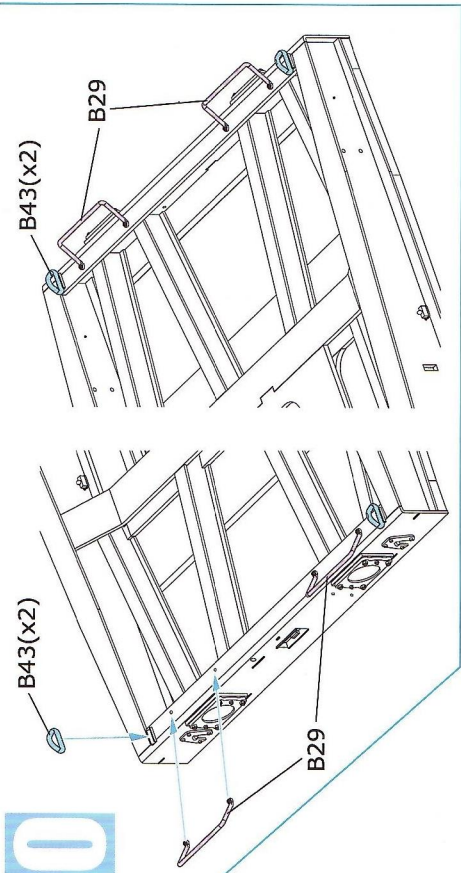

11

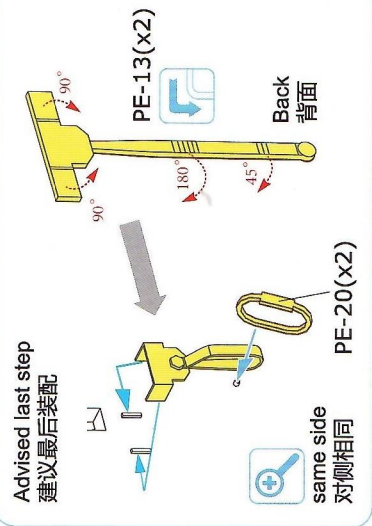
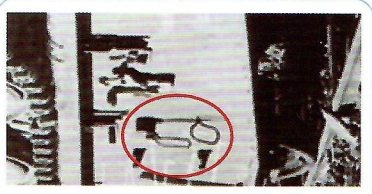
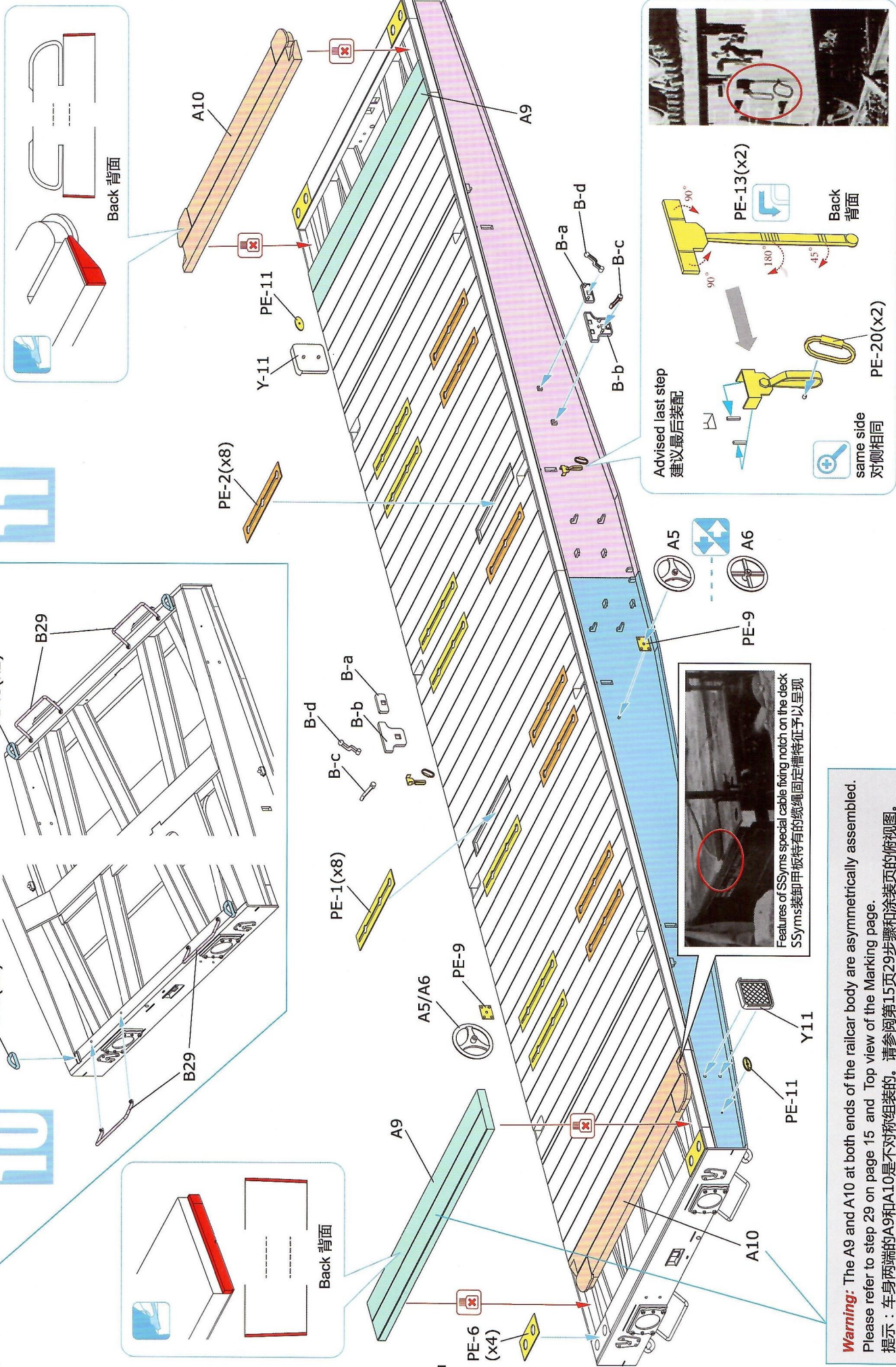

Warning: The A9 and A10 at both ends of the railcar body are asymmetrically assembled. Please refer to step 29 on page 15 and Top view of the Marking page.
 提示：车身两端的A9和A10是不对称组装的。请参阅第15页29步骤和涂装页的俯视图。

12

x2

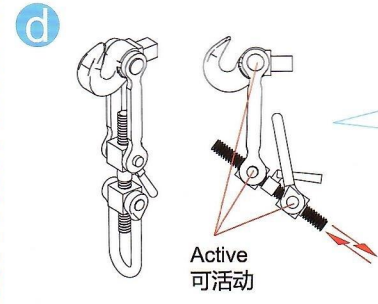
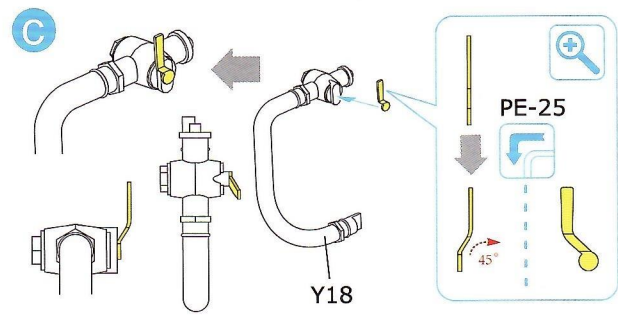
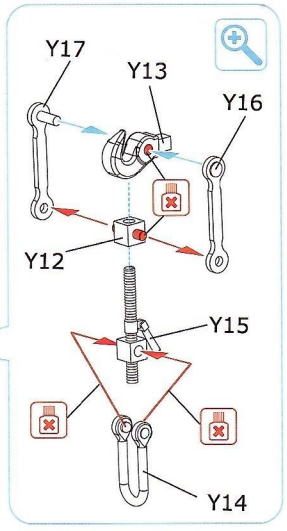
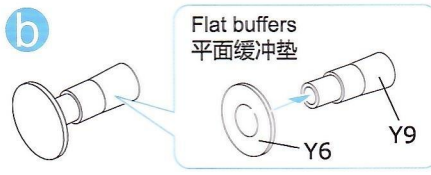
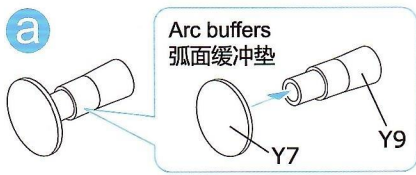

Warning: If need to replace the Y18 with a rubber brake hose and make two-car connection, please refer to step 28 on page 14.
 提示：如需使用橡胶制动软管替换Y18和制作双车连接形态，请参考第14页28步骤。

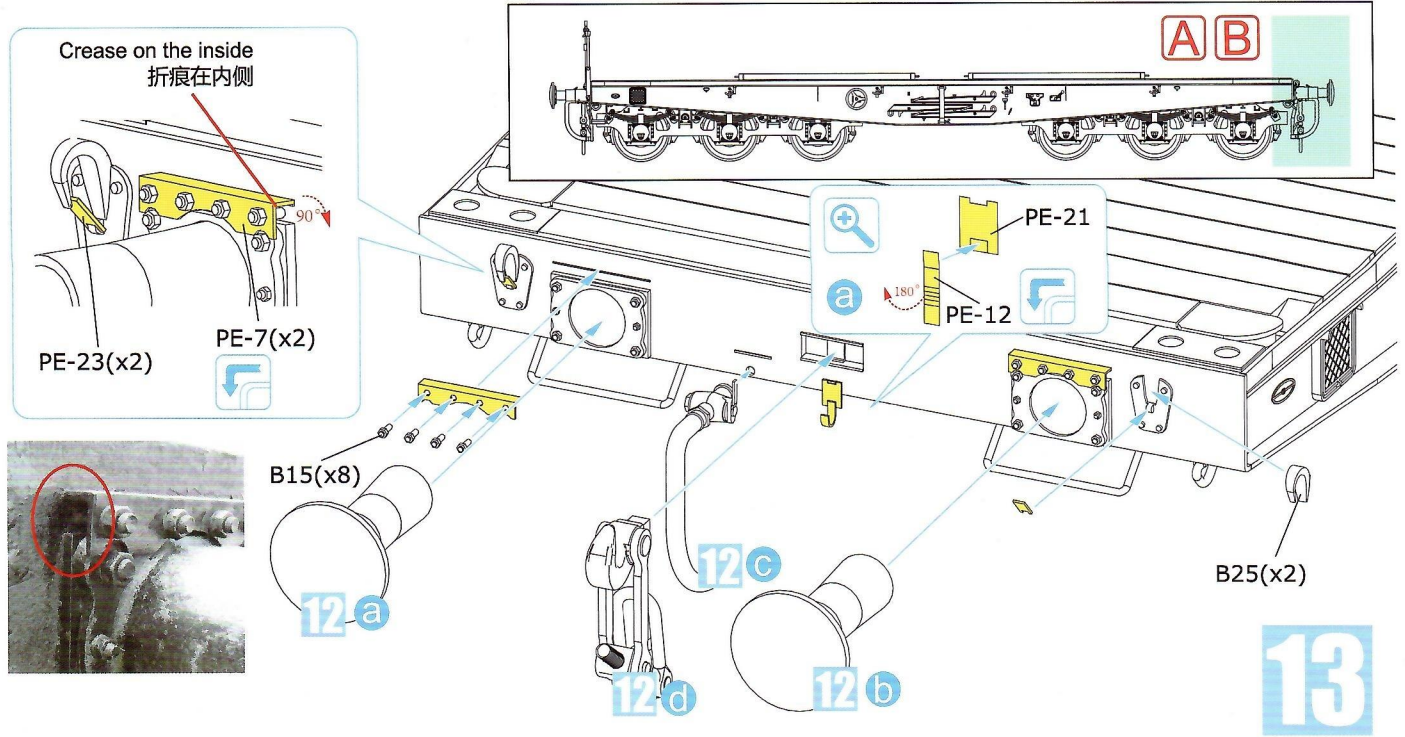

13

14

A Without handrail status
无扶手状态

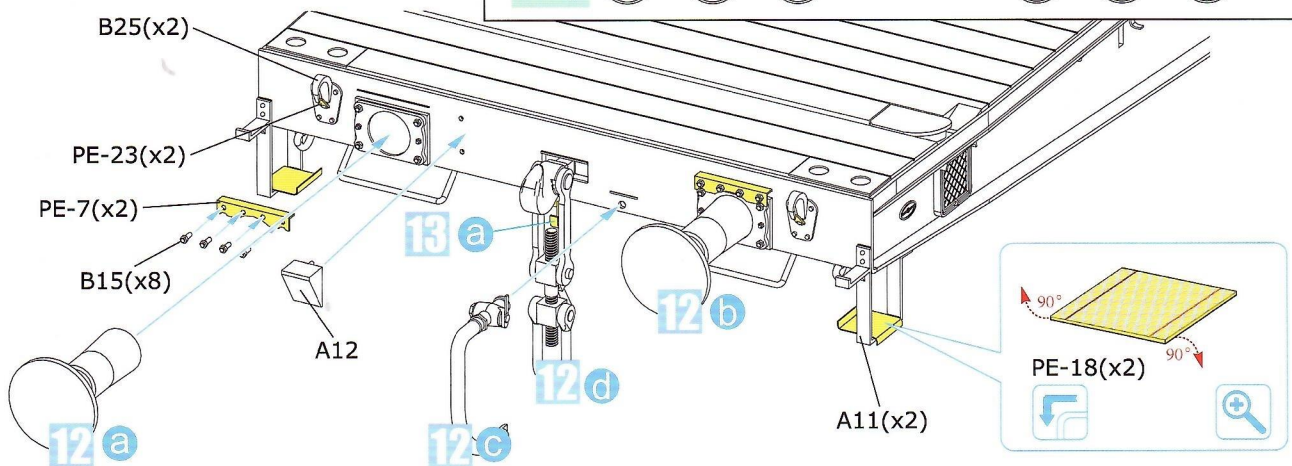
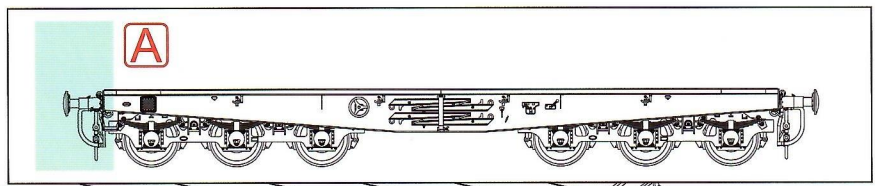

15

B with handrail status
带扶手状态

3 poles style of handrail
三柱扶手形态

4 poles style of handrail
四柱扶手形态

4

B-0

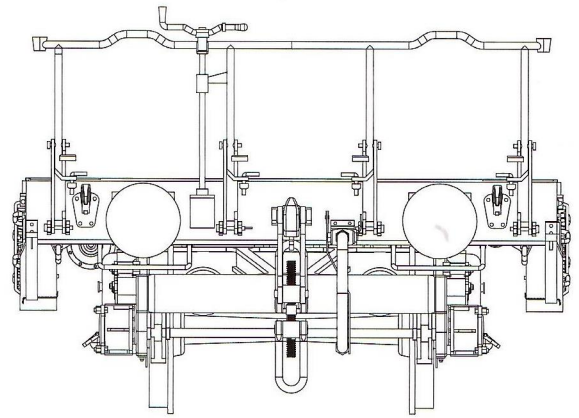
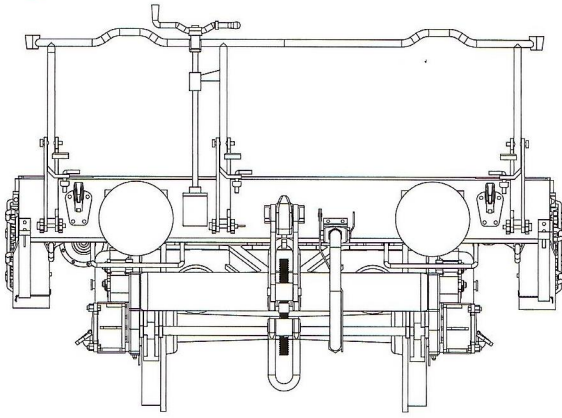

B-1

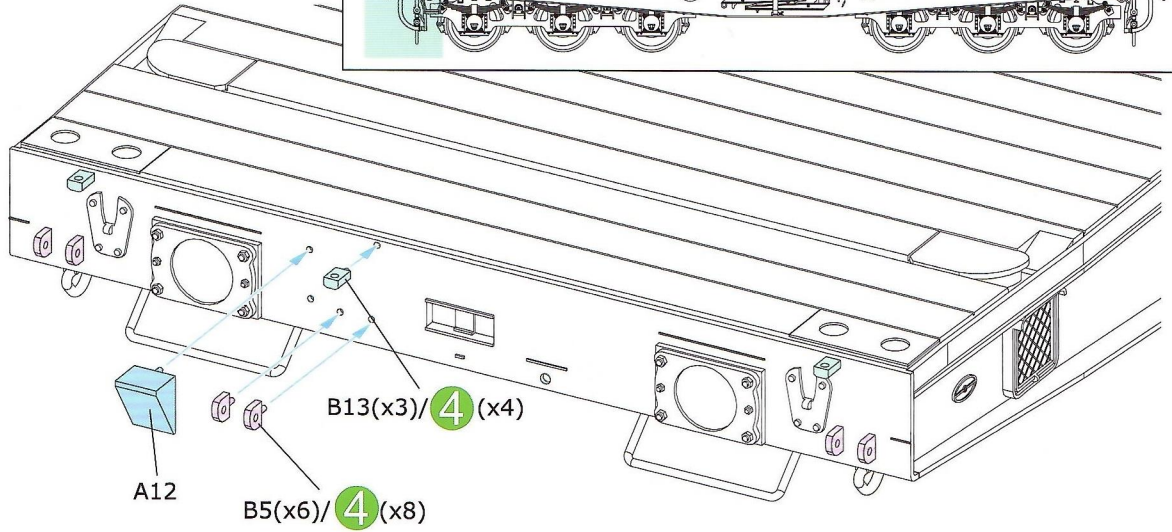
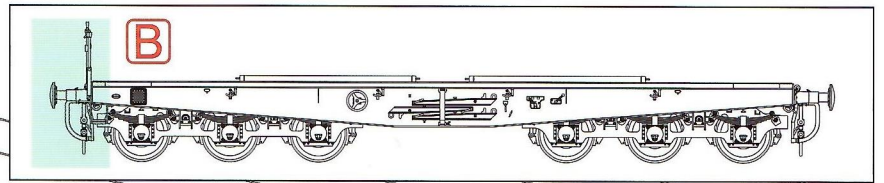

B-2

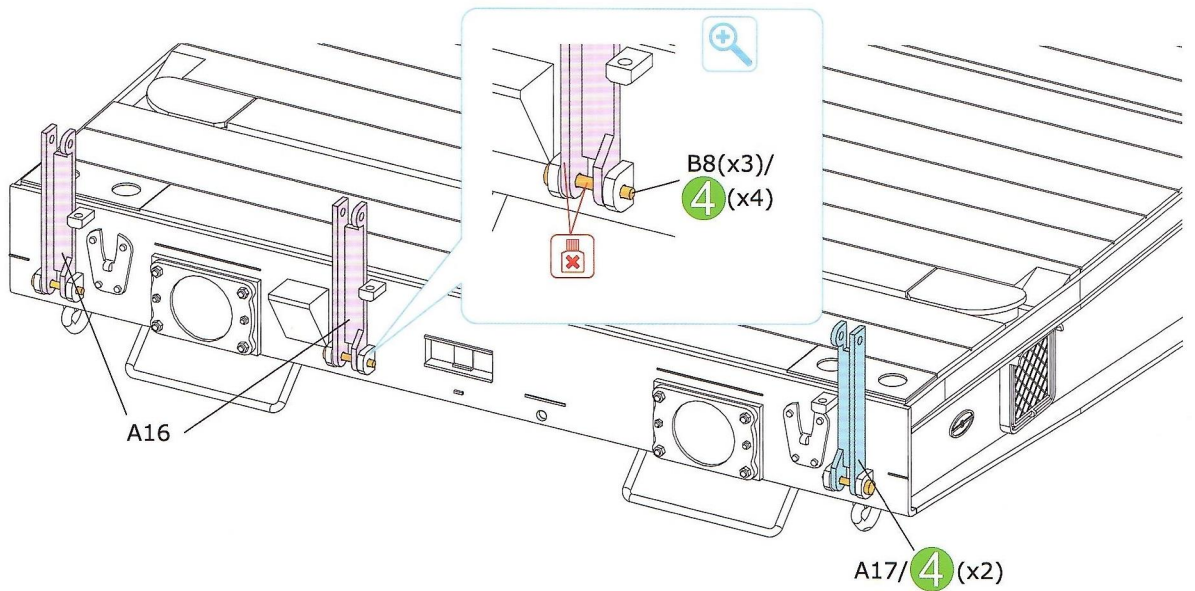

B-3

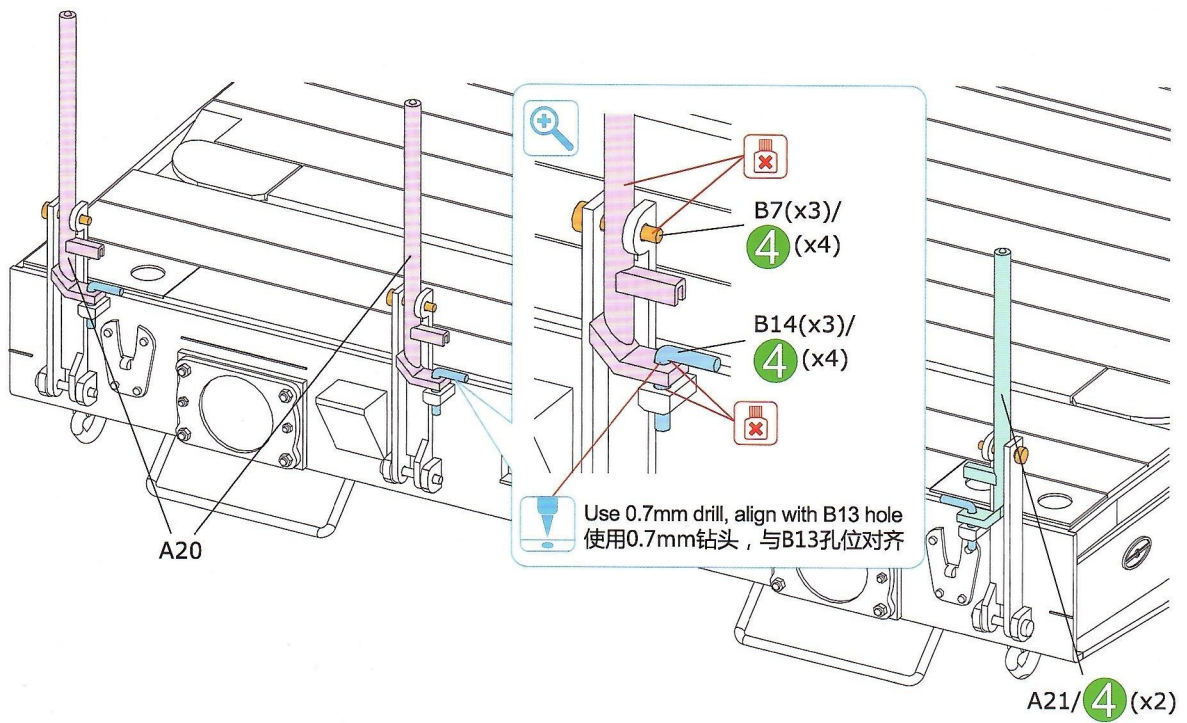

B-4

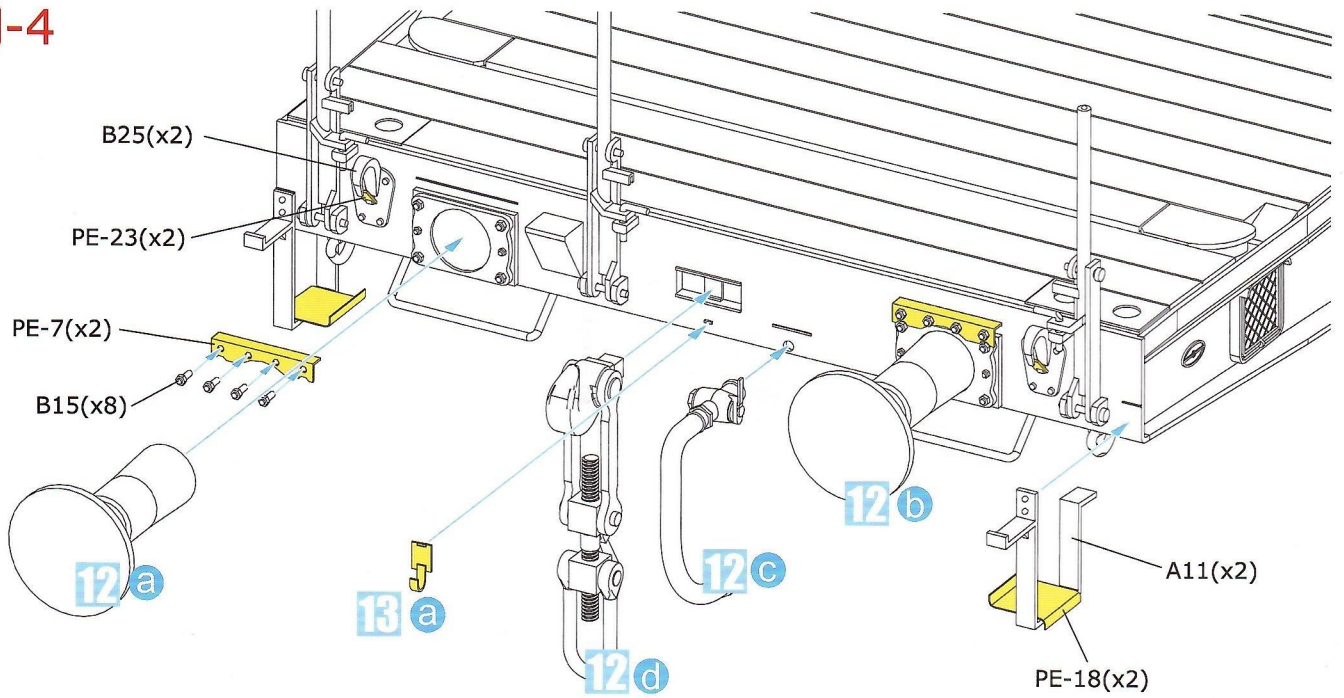

B-5

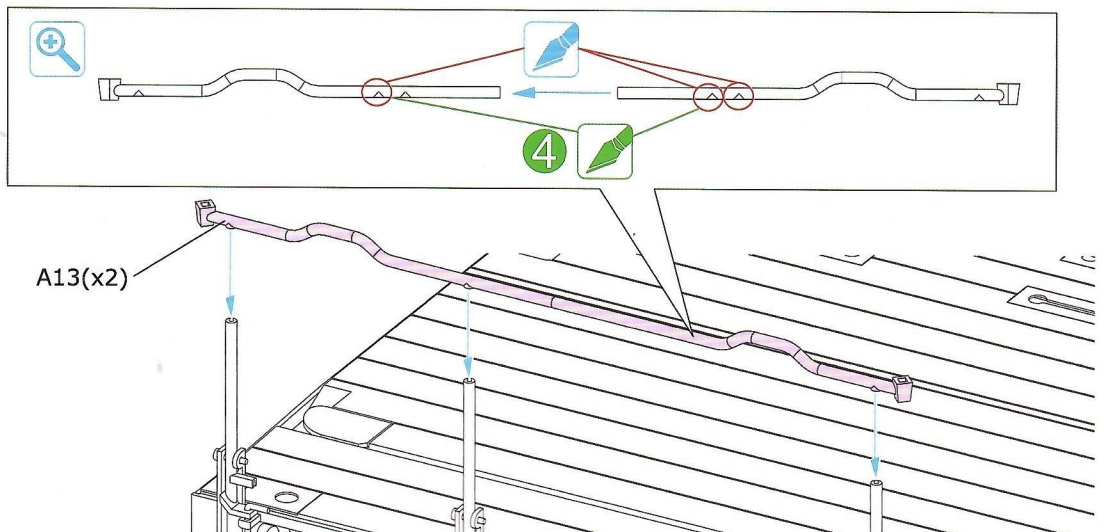

Handrail support status
扶手支撑状态

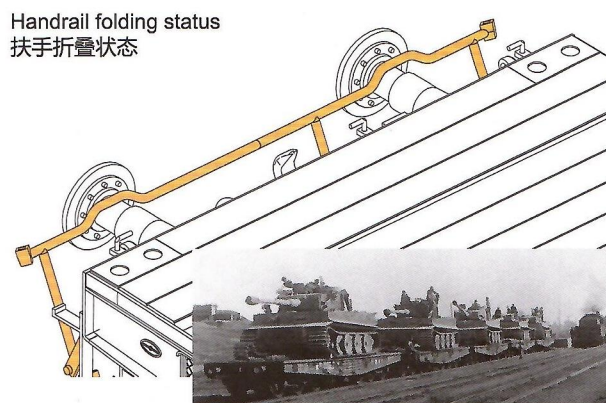
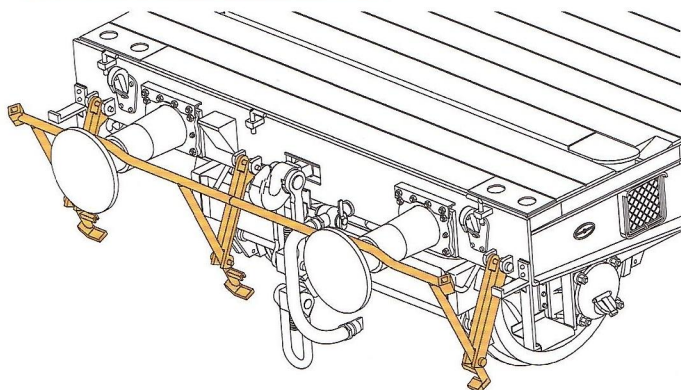
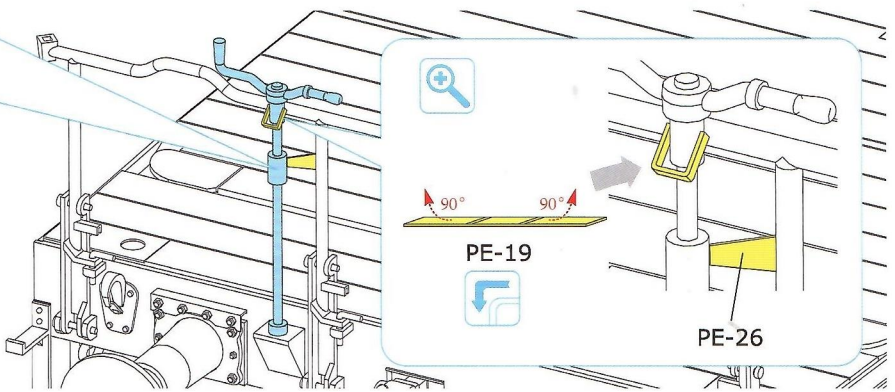
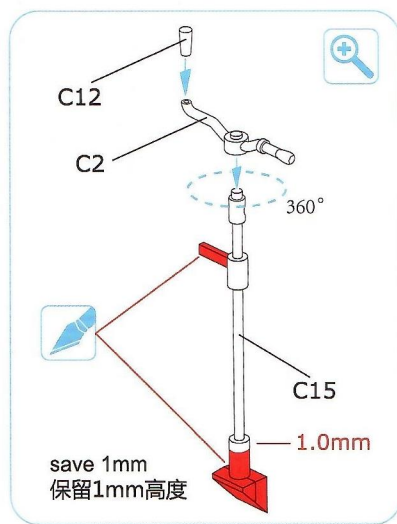

Handrail folding status
扶手折叠状态

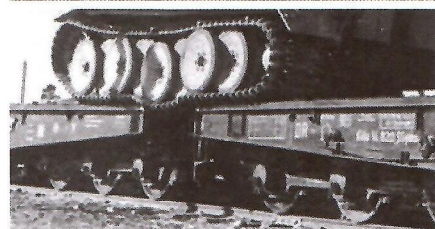
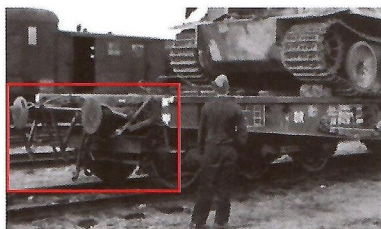
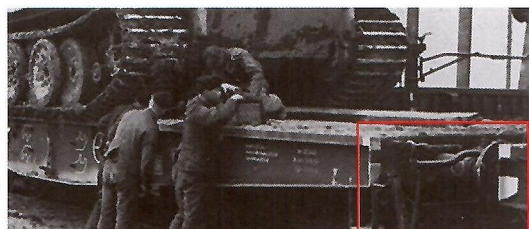

During WWII, the long-distance transportation of military vehicles was mainly depended on railway. The folding handrails are designed to facilitate heavy tank fleets to drive directly on tandem flat transport trains for fast loading and unloading.

二战期间，军用车辆的长途运输主要依靠铁路。折叠扶手的设计是为了方便重型坦克车队能直接在串联的平板运输列车上行驶，实现快速装卸。

16

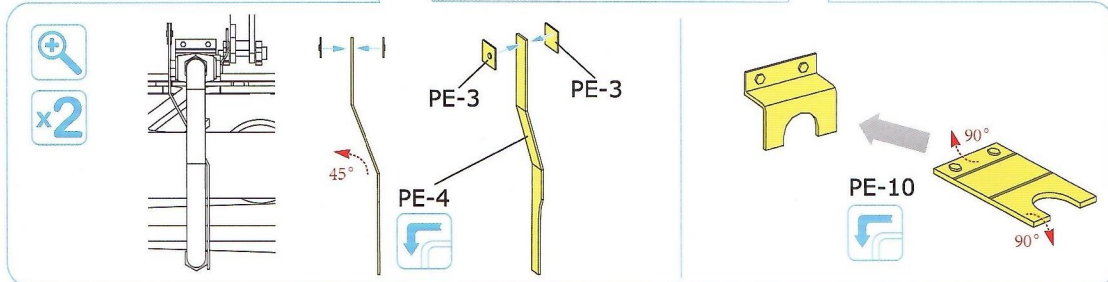
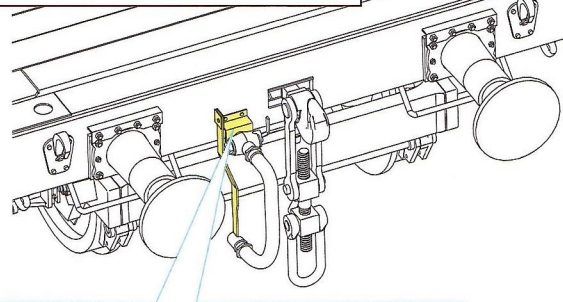
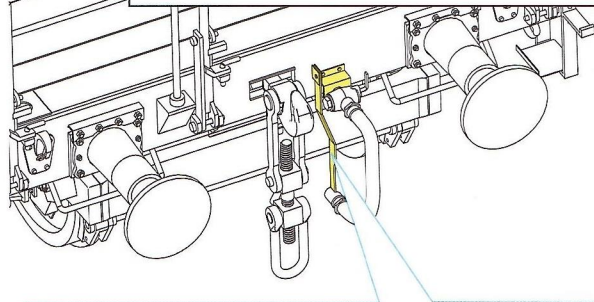
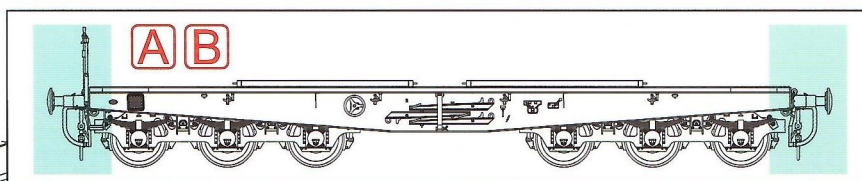

17

x2

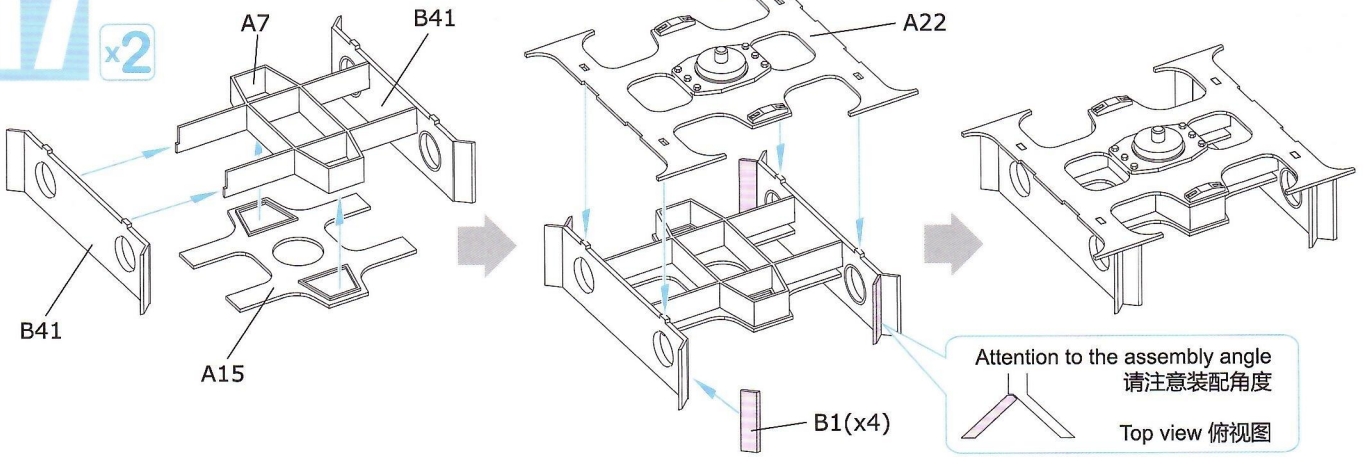

Attention to the assembly angle
 请注意装配角度
 Top view 俯视图

18

x4

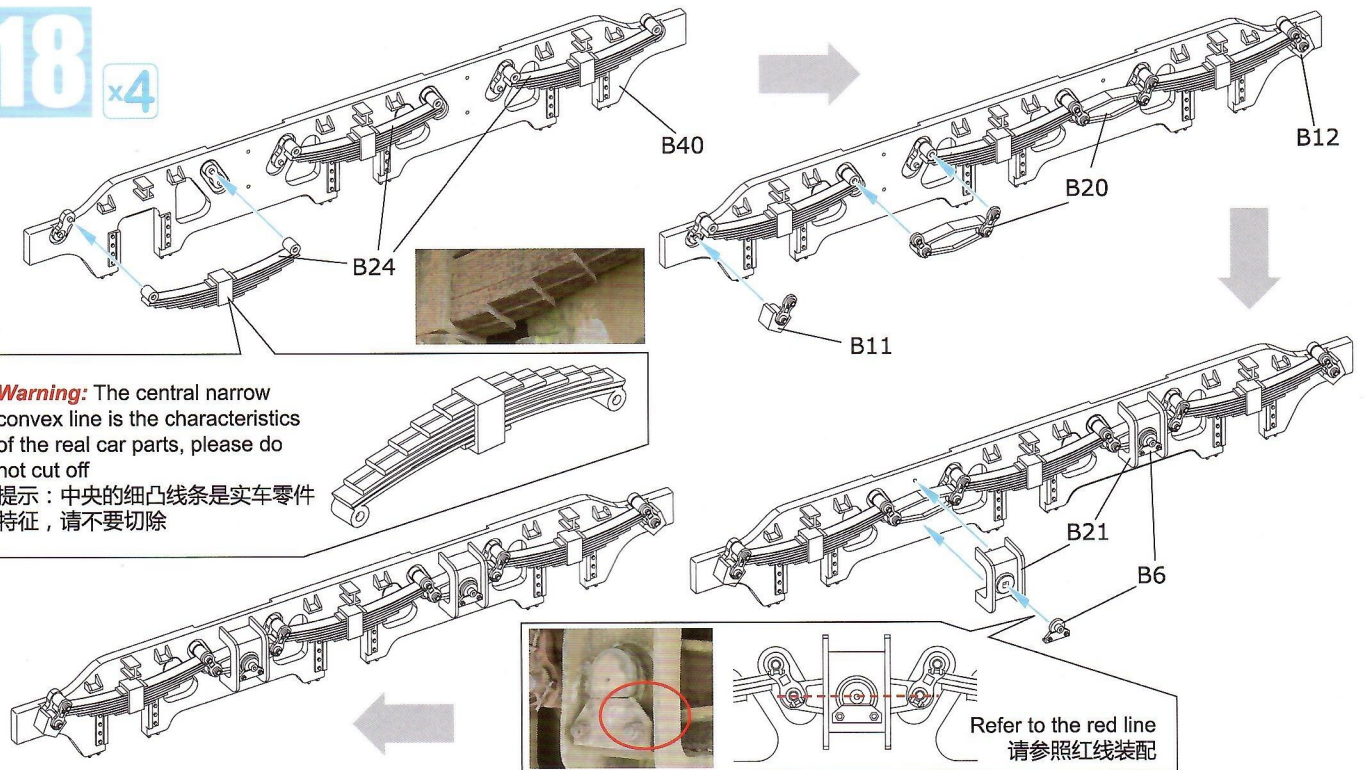

Warning: The central narrow convex line is the characteristics of the real car parts, please do not cut off
 提示：中央的细凸线条是实车零件特征，请不要切除

Refer to the red line
 请参照红线装配

19

x2

b x2

c x4

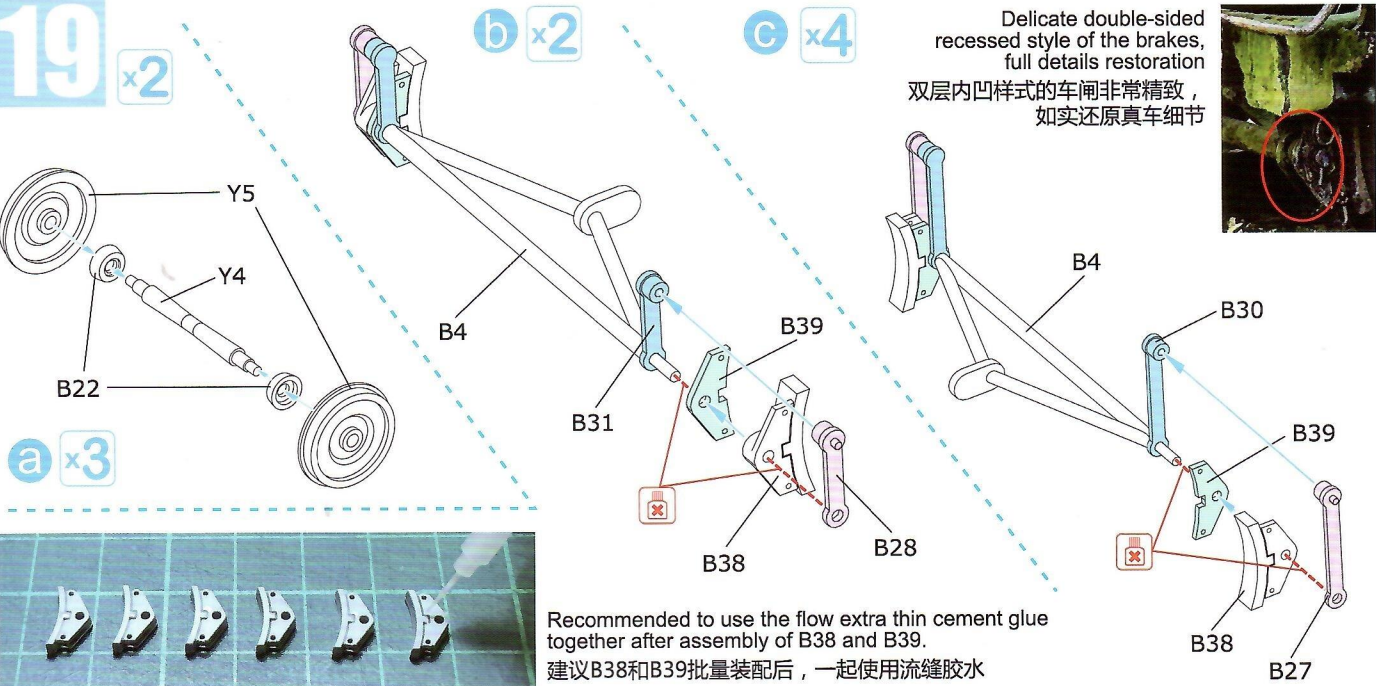

Delicate double-sided recessed style of the brakes, full details restoration
 双层内凹样式的车闸非常精致，如实还原真车细节

Recommended to use the flow extra thin cement glue together after assembly of B38 and B39.
 建议B38和B39批量装配后，一起使用流缝胶水

20 x2

19 c

19 b

19 b

18

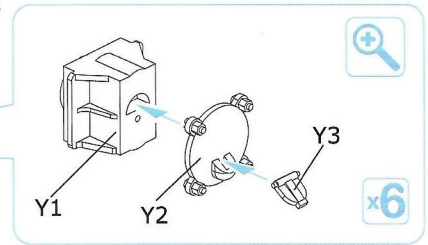

21 x2

17

B16

B17

B34(x2)

B17

B2(x2)

B16

22 x2

23 x2

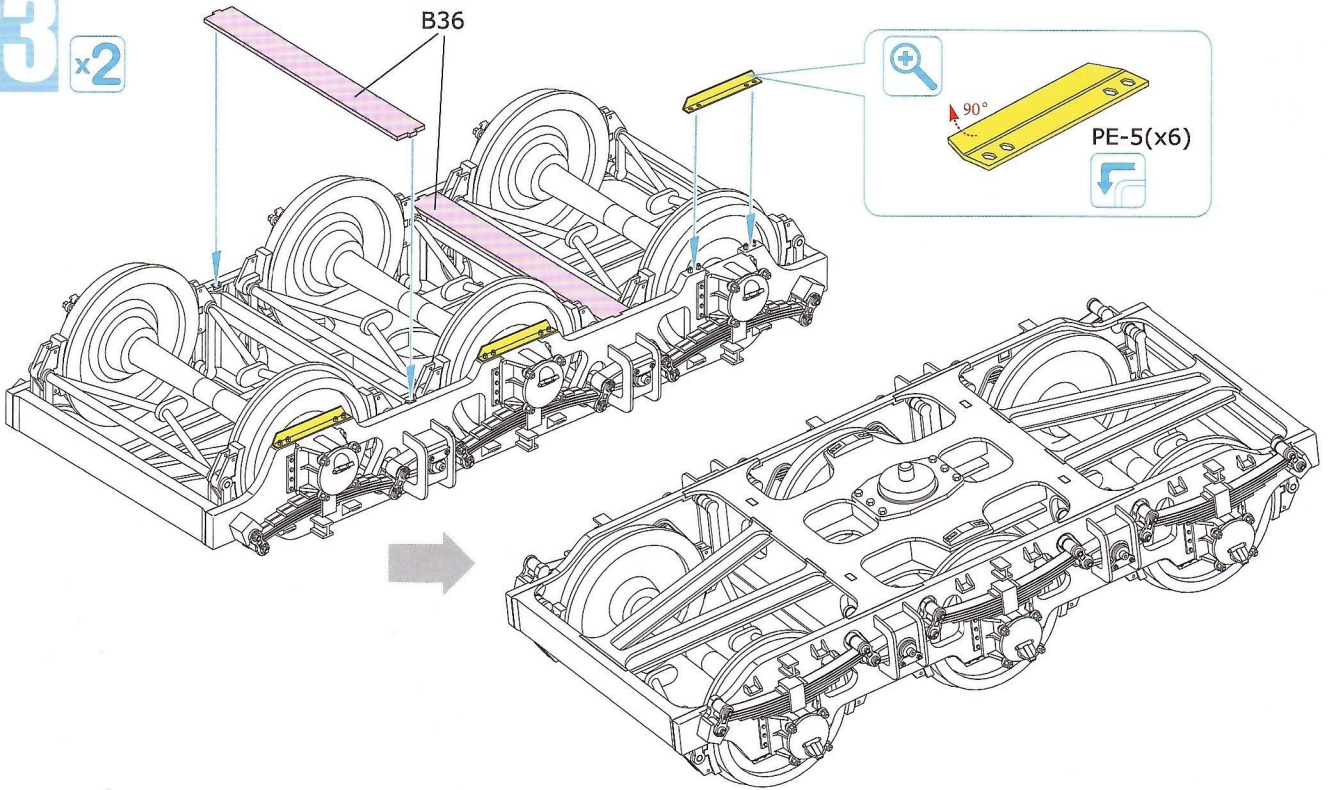

24

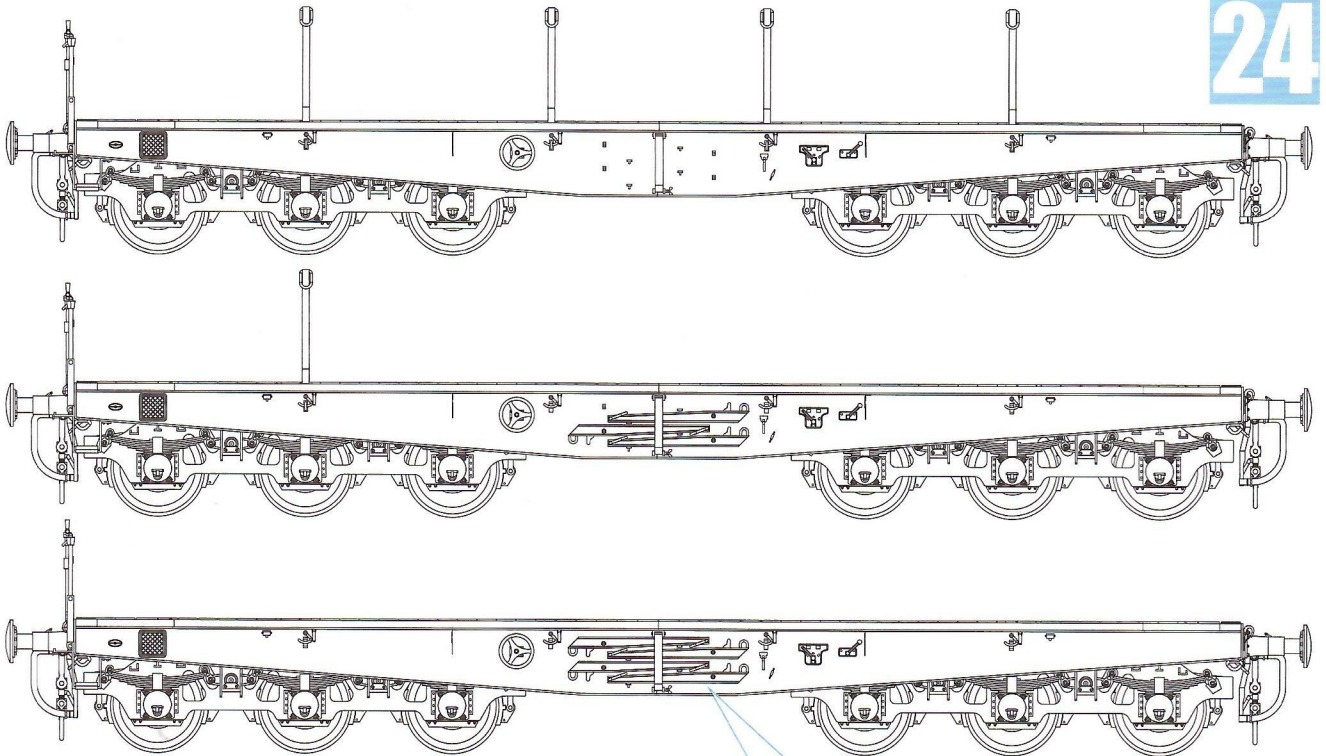

same side
对侧相同

Attention to the steps of the No.7 or No.12 decals
请注意7号或12号水贴的先后步骤

B42

B32

A1

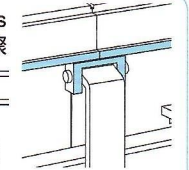

A1 and edge retention
of car body same plane
A1与车体边缘
保持同一平面

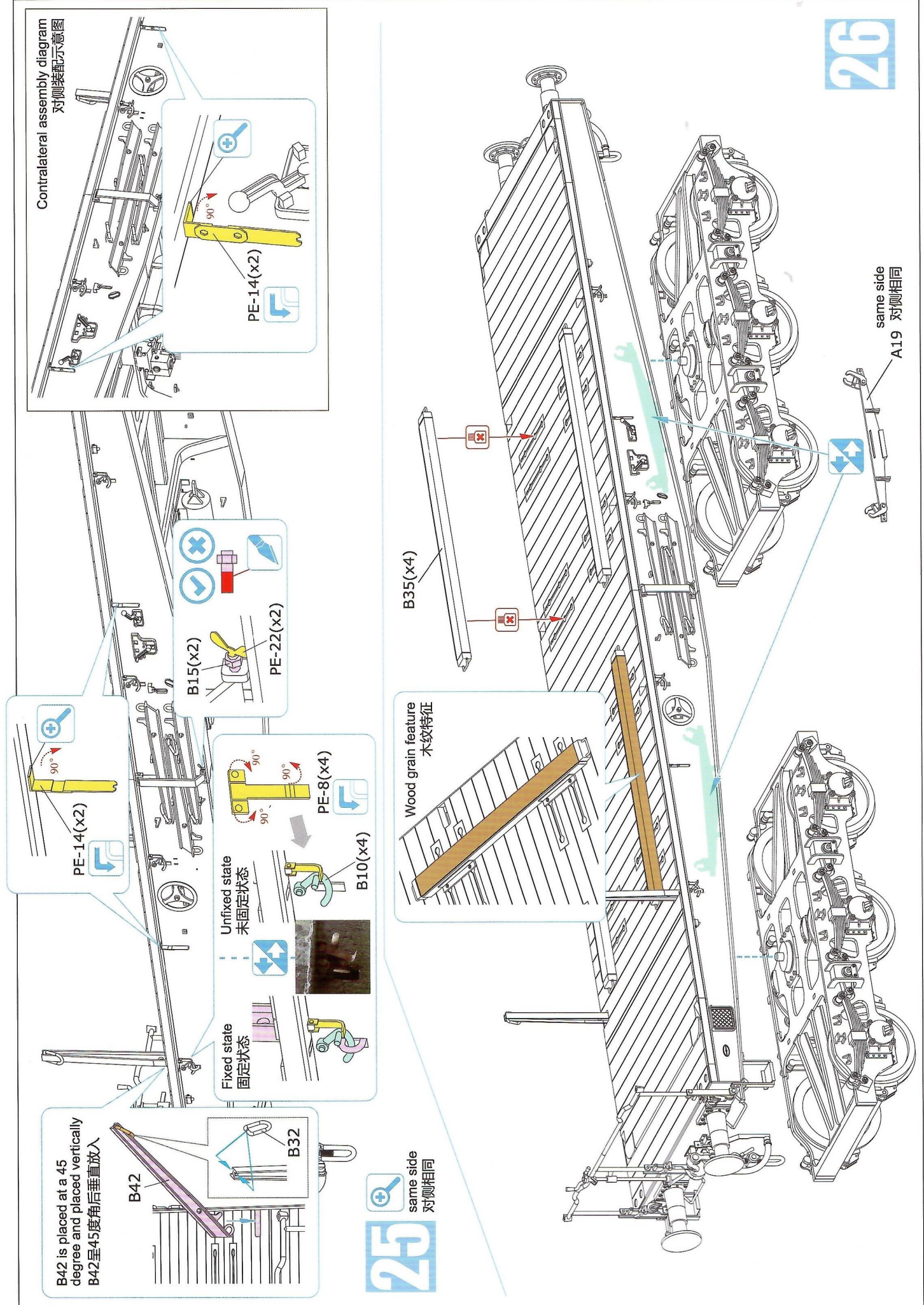

B42 is placed at a 45 degree and placed vertically
B42呈45度角后垂直放入

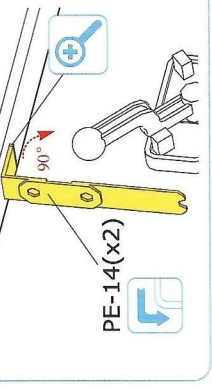
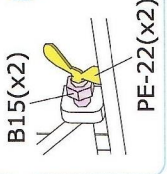
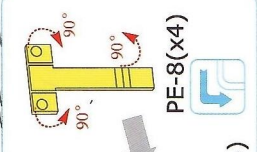
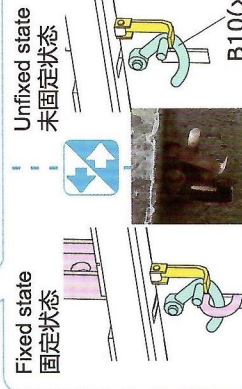
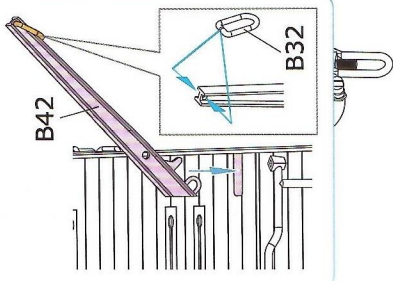

Wood grain feature
木纹特征

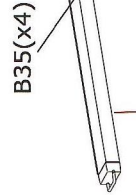
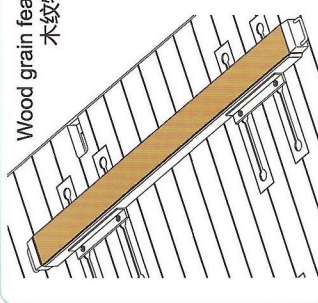

same side
对侧相同



same side
对侧相同



27

Wooden wheel stopper 木质止退器

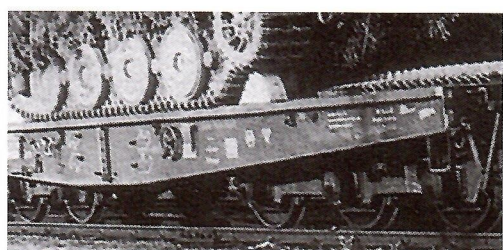
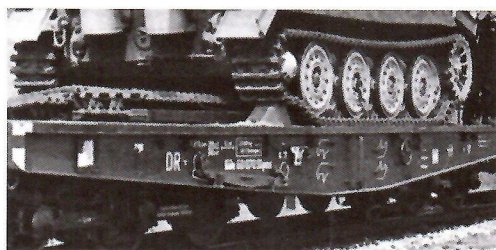
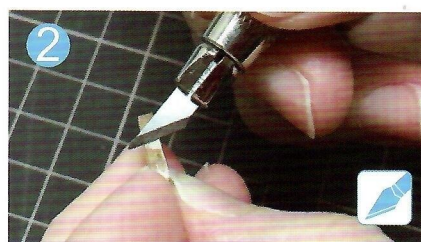
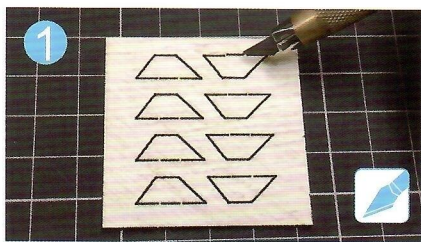
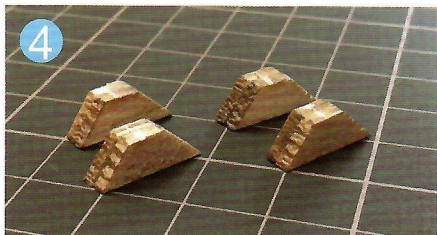
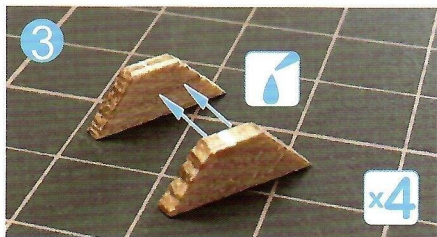

28

How to make rubber brake hose 橡胶制动软管制作示意

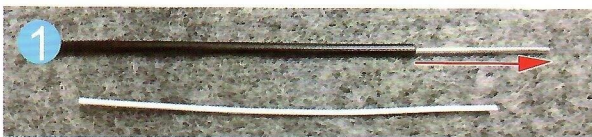

Remove the metal core from black hose
取出黑色软管的金属内芯



Load white hose 装入白色软管

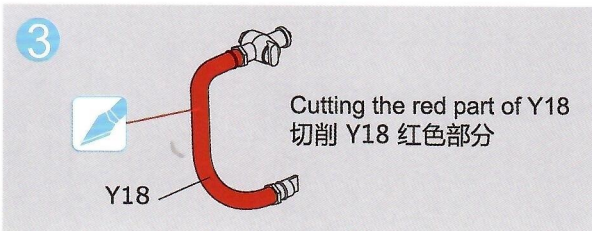

Cutting the red part of Y18
切削 Y18 红色部分

Y18



Intercept the black hose about 25mm, and then glue the plastic parts of both ends of Y18
截取黑色软管约25mm，与Y18两端塑料零件粘合。

a



Separate car fixed states
单车固定状态

b

Two-car connection status
双车连接状态

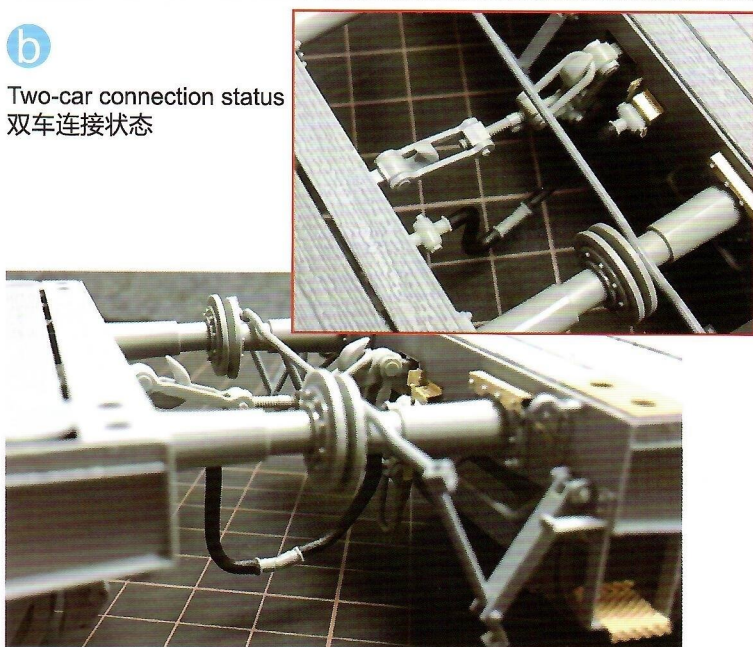

29

How to fixed vehicle with metal cable 金属缆绳固定车辆的使用示意

1

Select cable fixing
buckles 4 PCS from
other brand model kit
从其他品牌套件中选用
4个钢缆固定扣

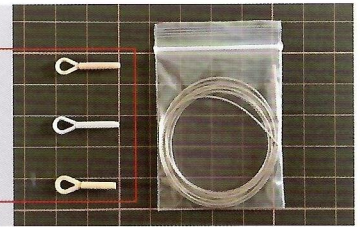

2



a ± 210 mm

b ± 180 mm

3

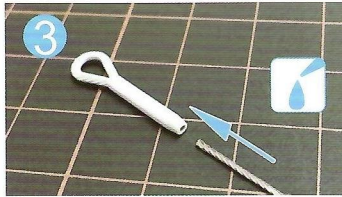

4

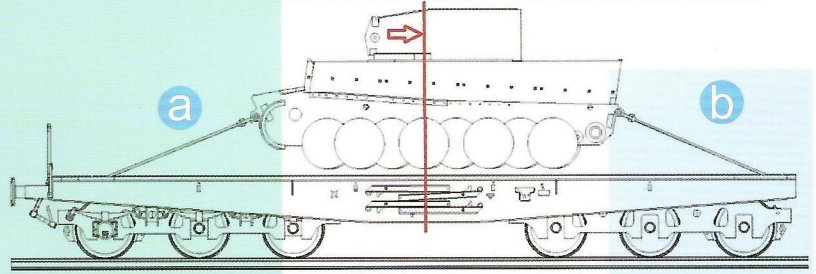
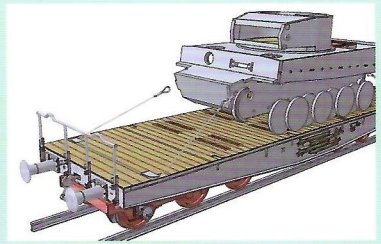
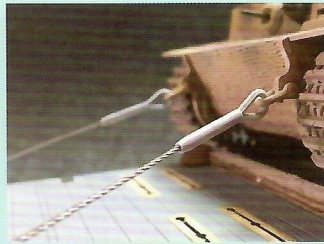
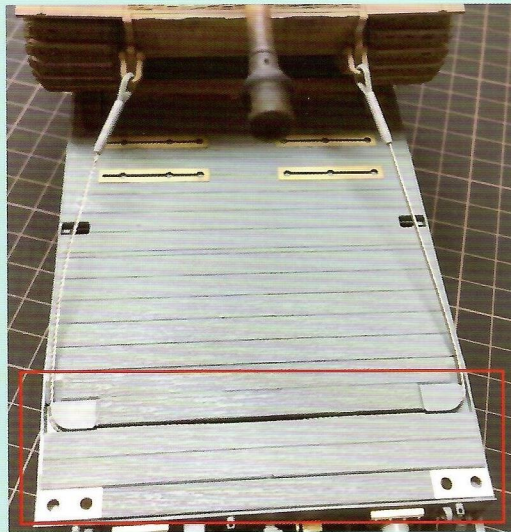
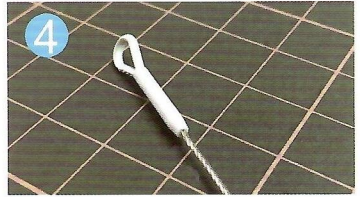

Warning: The A9 and A10 at both ends of the railcar body are asymmetrically assembled. Please check the features from red frame.
提示：车身两端的A9和A10是不对称组装的，请核对红框内的特征。

Normally the 3rd or 4th wheel center of Tiger tank is aligned with the center axis of the railcar body
通常虎式坦克的第三轮或第四轮中心与车体的中轴线对齐

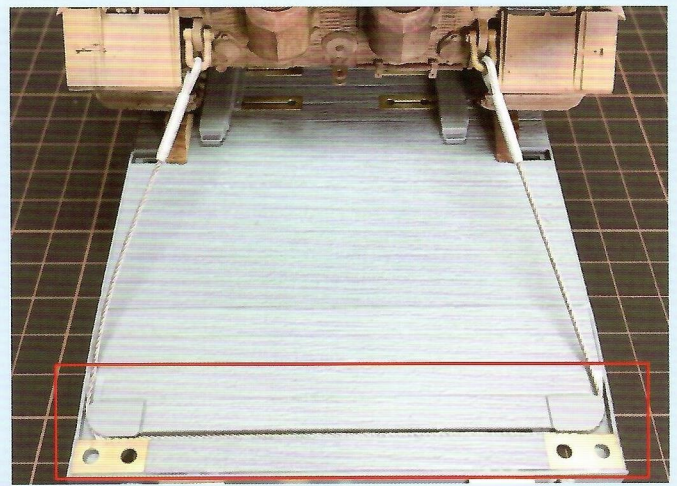
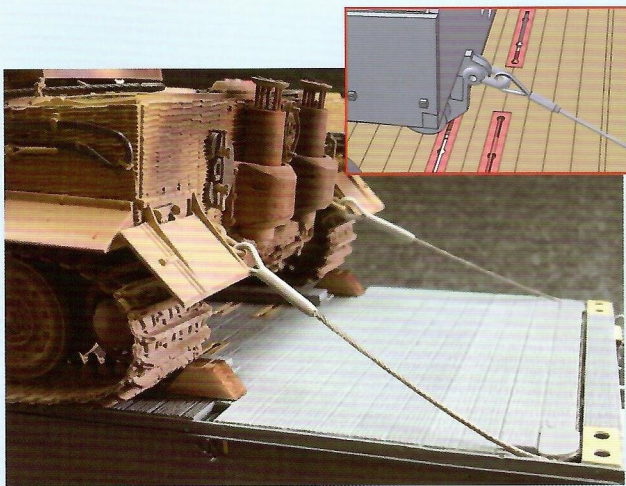

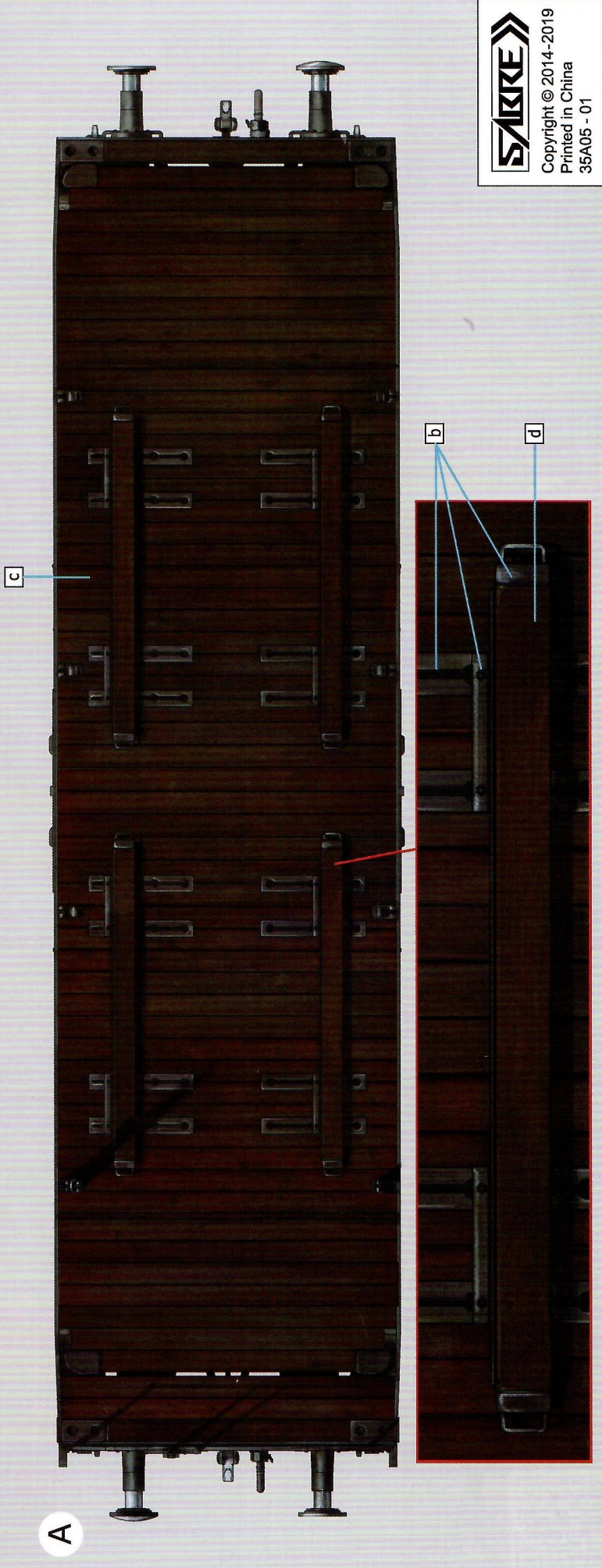
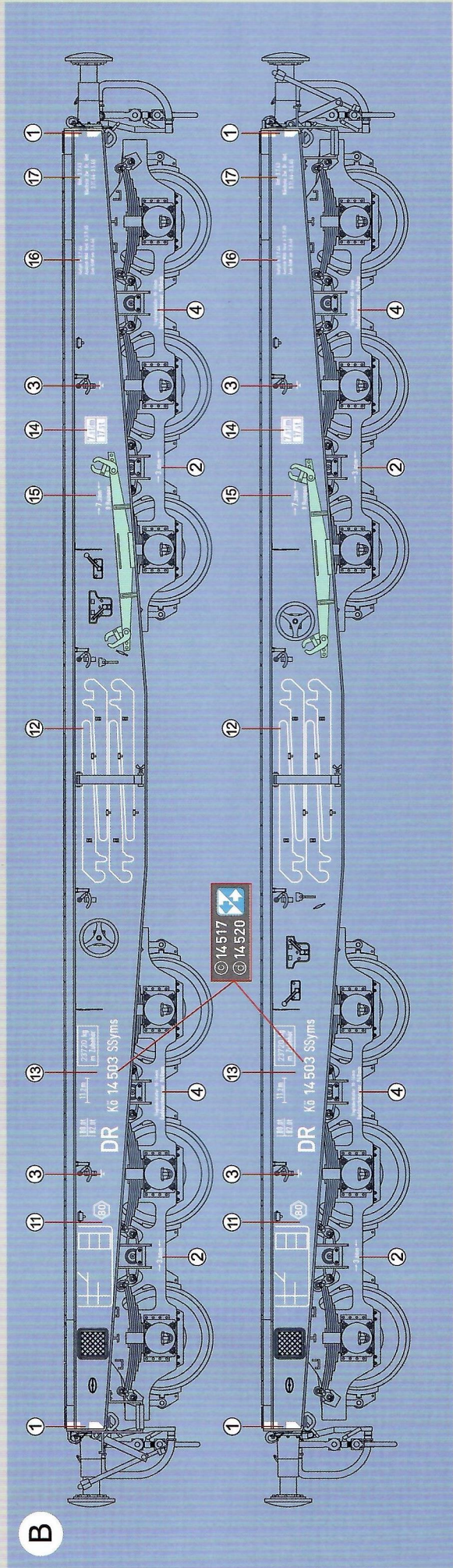

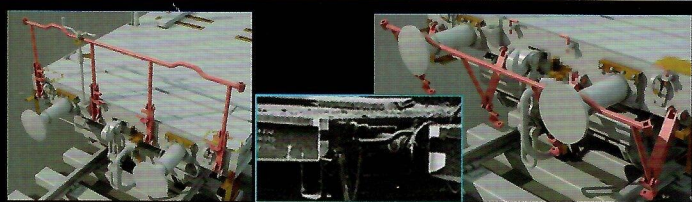

True restoration of the V-shaped handrail of the real car 真实还原实车可折叠的V形扶手

detailed SSyms special cable fixing notch on the deck
SSyms 装卸甲板上特有的缆绳固定槽细节予以呈现

The hollowed out loading dock and the card slot formed by the PE can move the positioning stake laterally
镂空设计的装卸甲板和PE装配成的卡槽,可使定位木桩横向移动



precise restoration of original frame 精准复刻车架结构

provides two options for assembly 提供两种款式的纹盘选择装配

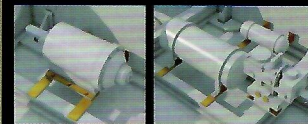

The main and auxiliary air cylinders and brakes of the vehicle are matched with PE to enhance the details.
车底主副风缸和制动装置搭配PE, 提升细节表现



complete restoration of bogie internal structure 完整表现转向架内部结构



rounded corners detail reproduced 按实车做了倒圆

rocker that can rotate 360 degrees, no more single shape 可旋转的摇杆拒绝单一造型

The hoisting hooks of the equipment during the WWII are also presented.
二战时期装备的随车吊装钩也经考证予以呈现

fixed pile strips are not only detachable, but also can be matched with the positioning hooks in the vertical state of the deck to show the details.
固定桩条不仅可拆卸, 并且在甲板竖装状态下, 可与定位钩相匹配, 尽显细节

panel handles can be placed in a left and right fan shape 面板把手可左右扇形摆放

small feature of the side frame 细小特征表现

accurate details on bogie 精准细节的转向架

flexible hook to enhance the experience 可随意造型的活动挂钩提升多样性和可玩性

separate rivets and PE showing the hollow detail of the SSyms special protective plate 独立铆钉和PE的组合, 展现SSyms特有防护板镂空细节

detail features of the center of the shock absorbing spring 减震弹簧中心凸线的细节特征

feature of slightly raised corner 略微突起的边角特征

The details of the hook mouth seem simple, but strictly follow the characteristics of the real car 挂钩口的细节看似简单却严格遵循实车特征

with rivet detail in bottom 车底连杆均带有铆钉细节

The parts are not only easy to assemble, but also offer details of the original car 零件不仅容易组装, 且更能表现镂空细节

Delicate double-sided recessed style of the brakes, full details restoration 双层内凹样式的车闸非常精致, 如实还原细节
bottom bar of PE, easy simple to make and better to show the effect 底部挡条采用PE, 不仅制作简单, 而且更好地展现效果

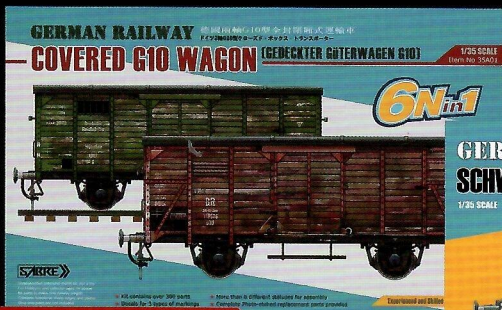

35A01 COVERED G10 WAGON



35A02 4(Axle) PLATTFORMWAGEN 50t Type SSys



35A03 2(Axle) FLATBED OMMR



✉ sabremodel@hotmail.com
www.sabremodel.com

9

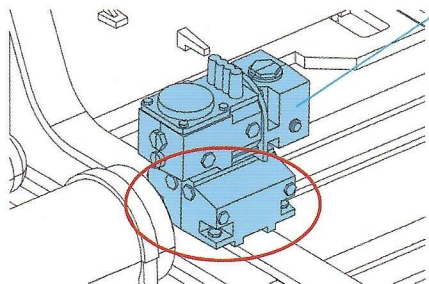

8

1

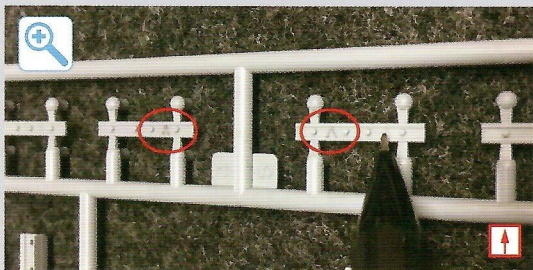

Before cut Z4/Z5 step,
please mark the back of the
part as shown up direction
在剪切Z4/Z5步骤之前，
请按图示在零件背面标记
向上方向

2

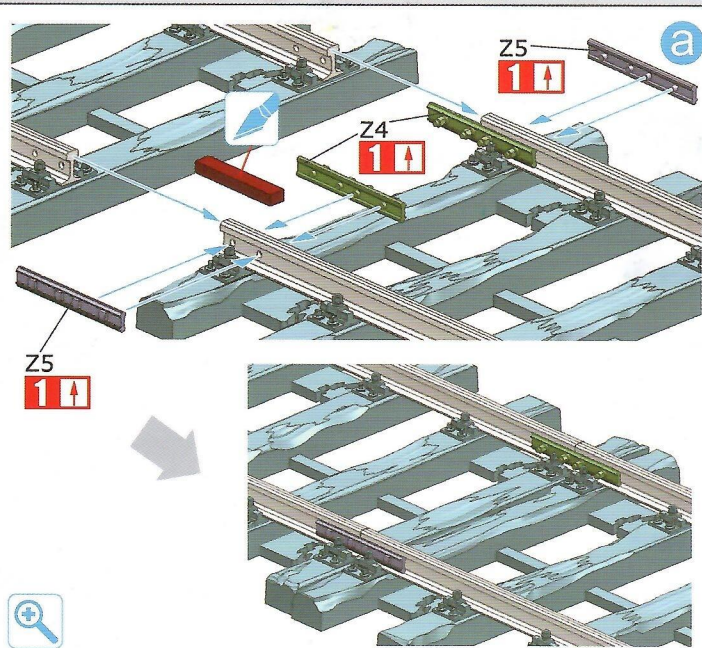
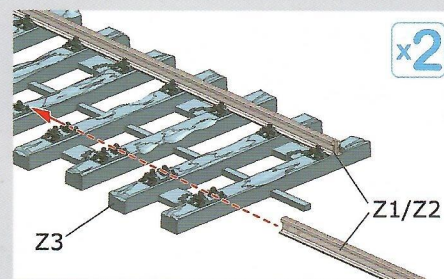

3

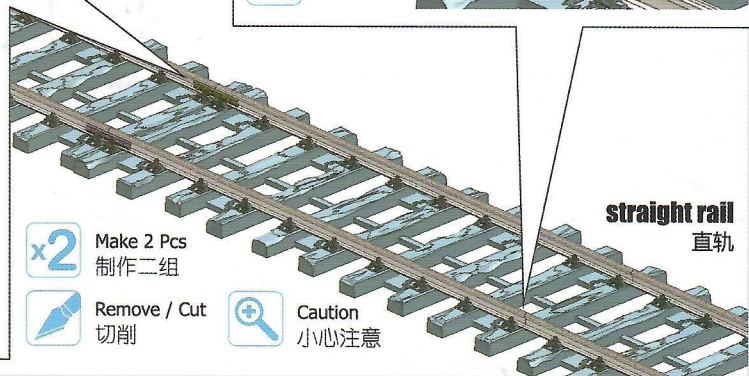
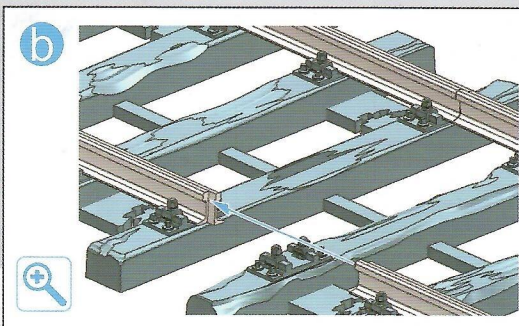

x2

Make 2 Pcs
制作二组



Remove / Cut
切削



Caution
小心注意

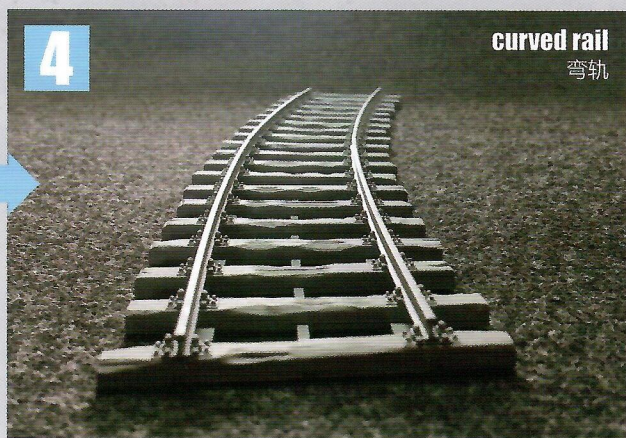
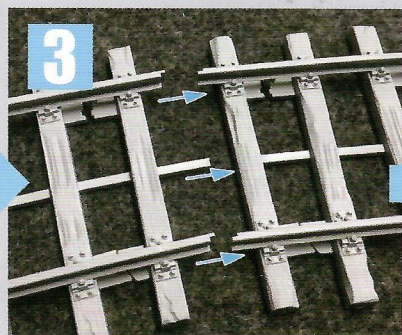
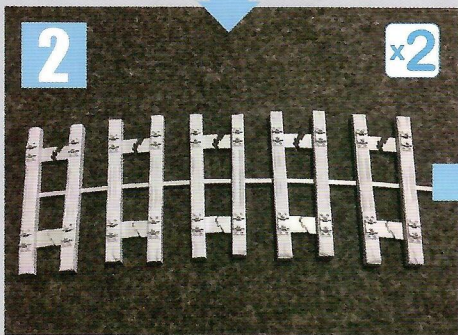
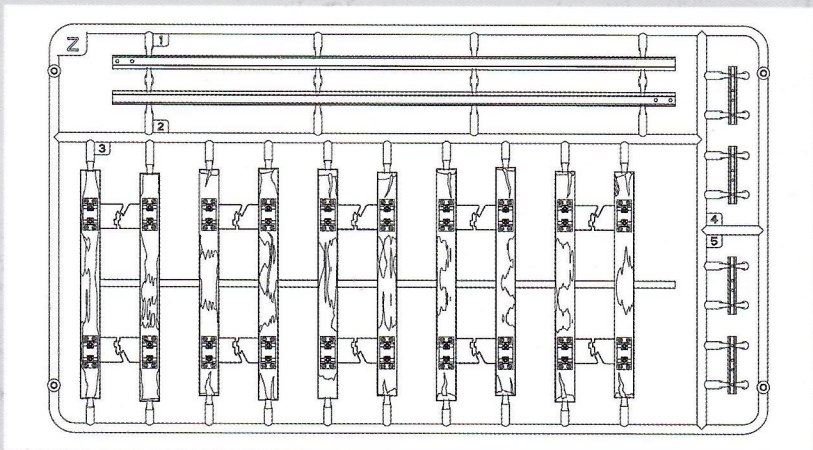
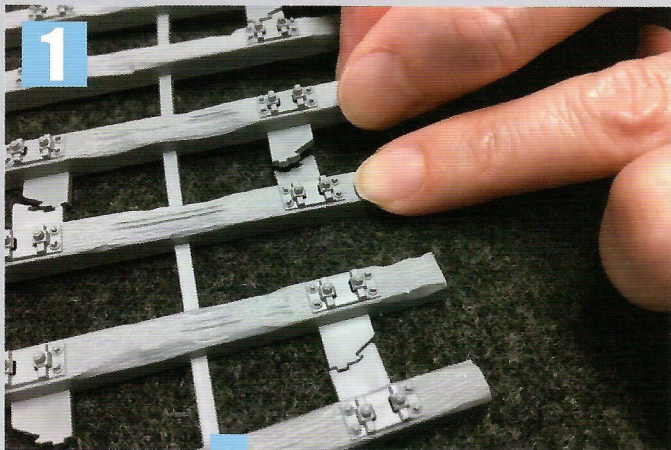

1:35 RAILWAY TRACK AND SLEEPER SET
35B06



✉ sabremodel@hotmail.com
www.sabremodel.com

14+

Kit suitable for ages 14 to adult
 本产品不适合14岁以下儿童