

North American T-6G Texan

T-6, "Texan", "Harvard", "Mosquito", "Tê-Meia", seja qual for o nome, o avião North American BC-1A, como originalmente foi designado, será sempre lembrado entre todos os entusiastas da aviação e por todos os que o pilotaram como um marco na história da Aviação: *O pilot-maker*.

Desenvolvido originalmente como um avião de treino básico para o Corpo Aéreo do Exército dos Estados Unidos na década de trinta, o NA A-T6, como a seguir foi designado, durante a Segunda Guerra Mundial e nas décadas seguintes, foi o treinador por excelência de milhares de jovens pilotos de várias nacionalidades.

Demonstrou a sua versatilidade, robustez e fiabilidade ao ser empregue em outras missões que cumpriu com a mesma eficácia de avião de treino, à medida que foi sendo substituído por outras aeronaves mais avançadas. Desde os céus da Guerra da Coreia (1950/53) até aos desertos do Norte de África e selvas da América Latina, foi empregue com sucesso em missões de combate. Também a Força Aérea Portuguesa o utilizou em África até ao início dos anos 70.

Dos quase 20.000 aviões produzidos, muitos existem ainda hoje preservados em museus, alguns mesmo em estado de voo, o que, para goáudio dos entusiastas, permite que o ronco do seu motor PW R-1340 possa ser ouvido ainda por mais alguns anos...

T-6, "Texan", "Harvard", sea cual sea, su nombre, el avión North American BC-1^A, como fué bautizado, jamás será olvidado por todos los aficionados a la aviación y sobre todo, por todos los que tuvieron la posibilidad de pilotarlo, como un mito histórico de la aviación: Un *pilot maker*.

Desarrollado en origen como un aparato de entrenamiento básico de las Fuerzas Aéreas de los Estados Unidos, en la década de los treinta, el NA A-T6, como fué designado a partir de la II Guerra Mundial, ha sido un entrenador de miles de jóvenes pilotos de las mas distintas nacionalidades.

Ha demostrado una gran fiabilidad, versatilidad y resistencia en muchas tareas que ha cumplido siempre con la máxima eficacia. Desde los cielos de Corea en los años 50, hasta los desiertos del Norte de África, Argelia, Sáhara Español, Selvas de América Latina, Angola, Mozambique y Guinea, ha cumplido siempre con fortuna sus misiones. De los casi 20.000 aviones fabricados, afortunadamente muchos estan todavía volando o preservados en museos, como por ejemplo el Museo del Ejército del Aire en Madrid.

Todos los aficionados esperamos seguir escuchando el peculiar sonido de su motor PW R-1340 por muchos años más...

T6, Texan, Harvard, Mosquito, whatever the name we may call it, the North American BC-1A aircraft (the *pilot-maker*), as originally was designated, will always be remembered among every aviation enthusiasts and all those who pilot it, as a true landmark in aviation history.

Originally developed as a basic training aircraft for U.S.Army Air Corps in the thirties, the NA AT-6, as was called after, was the aircraft trainer "par excellence" for thousands of young pilots of many nationalities, during and after the WWII.

This aircraft showed its robustness, versatility and reliability, beeing employed in many missions. From the skies of Korean War (1950/53), through the Northern Africa deserts and Latin America Jungles, it achieved quite success in combat missions, anti-guerrilla airplane, specially by Portuguese, French and Spanish Air Forces in their former African colonies, till early seventies. Of the almost 20.000 T-6 aircrafts produced, in many versions, fortunately, a number survived today, beeing displayed in museums and in flying condition, which for enthusiasts sake will allow to all of us keep listening the sound of its PWR-1340 engine for some years to come...

T6, Texan, Harvard, Tomcat, quel que soit son nom le plus connu, l'avion North American BC-1A, son premier nom (le *pilot-maker*), sera toujours souvenu par les fans de l'aviation et par tous ceux qui l'ont piloté, comme une référence dans l'histoire de l'aviation mondiale.

Developé originairement comme un avion d'entraînement basique pour le U.S.Army Air Corps, dans les anées 30 le NA AT-6 (la nouvelle désignation) a été l'entraîneur par excellence de milliers de jeunes pilotes de plusieurs nationalités.

Le T-6 a démontrée sa versatilité et fiabilité en intervenant avec efficacité en des plusieurs missions. Dès les ciels de la Corée (1950/53) jusqu'aux déserts de l'Afrique du Nord et les jungles de l'Amérique du Sud, il a été utilisé avec du succès en des missions anti-guerrilla.

Des presque 20.000 avions produits, heureusement, encore aujourd'hui ont peut en trouver plusieurs exemplaires bien soignés dans des musées, quelques uns même en des conditions de vol, ce qui fait la joie des fans de l'aviation en permettant aussi d'écouter encore le ronflement de son fameux moteur PW R-1340 pour quelques anées à venir...



Ref 0201

2ª Edição 1998

1

A

Cromato Zinco Verde
Interior Green

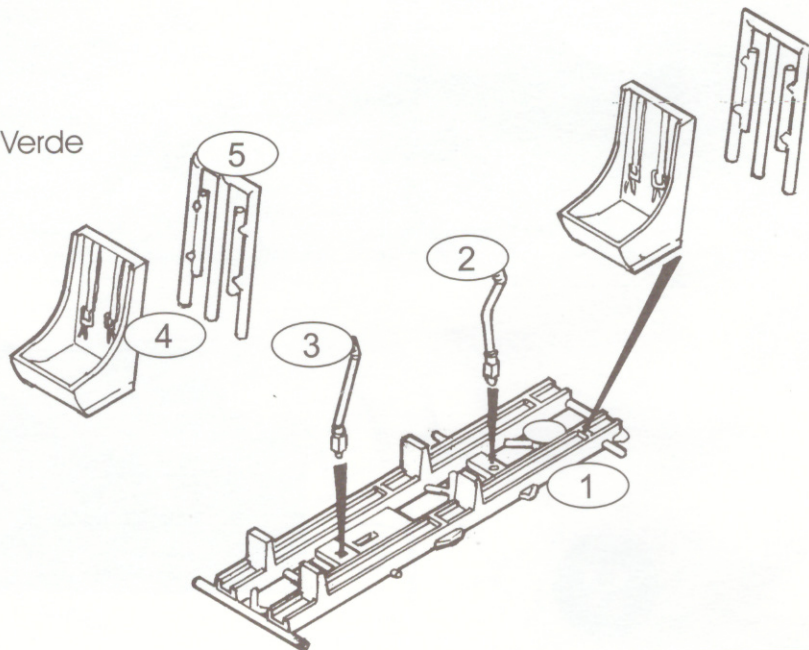

	Revell	Humbrol	Aeromaster	Xtracolor	G. Sangyo	F.Standard	Testors
A	32361	151	1049 ac	X 408	H 58 ac	34151	1734
B	31302	33	9001	X 404	H 12 ac	37038	1749
C	31199	56	N. A.	X 500	218	17178	1781

3

Preto Mate
Mat Black
Noir Mat

B

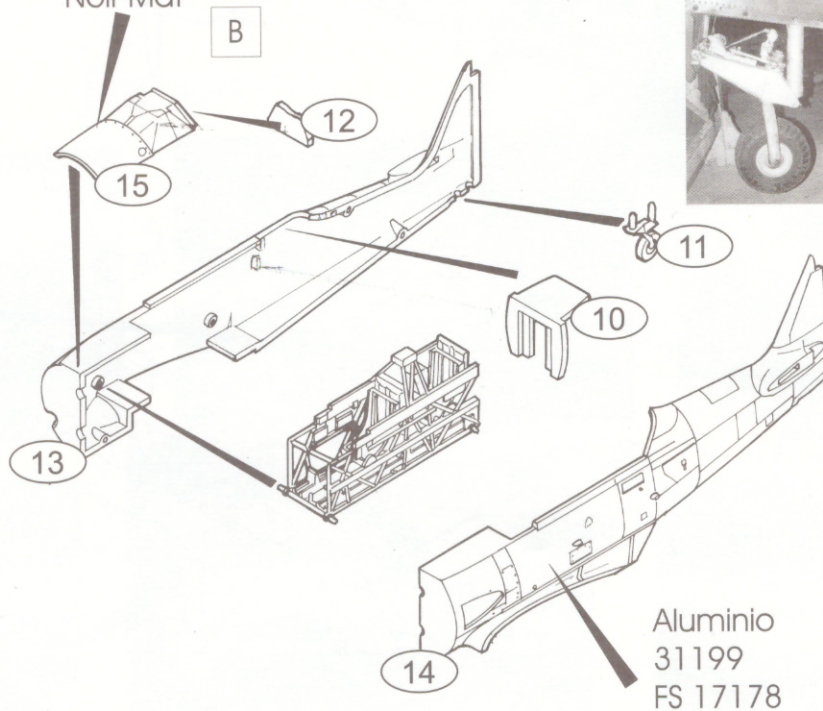

Aluminio
31199
FS 17178

C

2

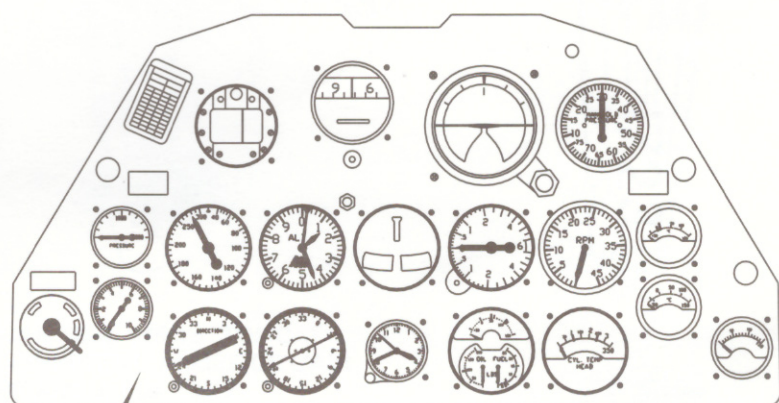
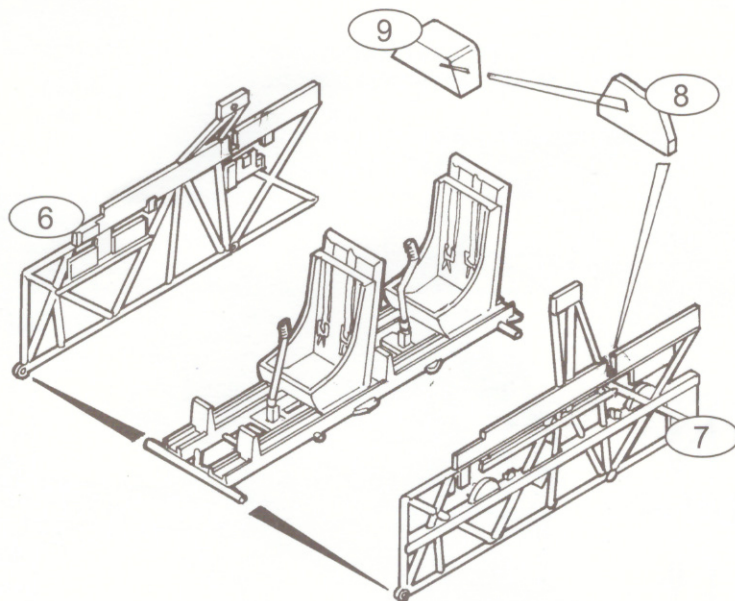

4

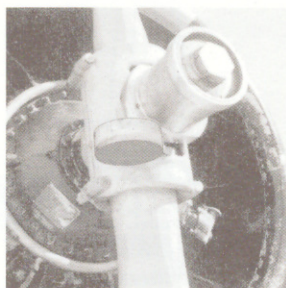

Preto Mate
Matt Black
Noir Mat
31302

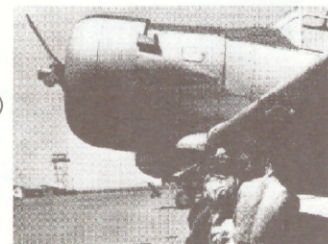
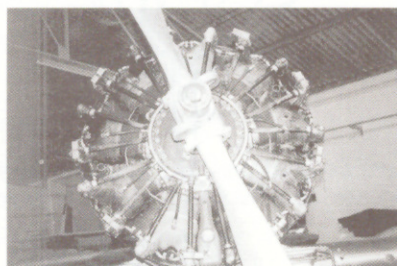
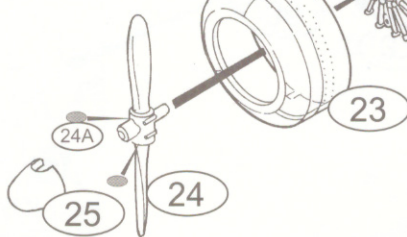
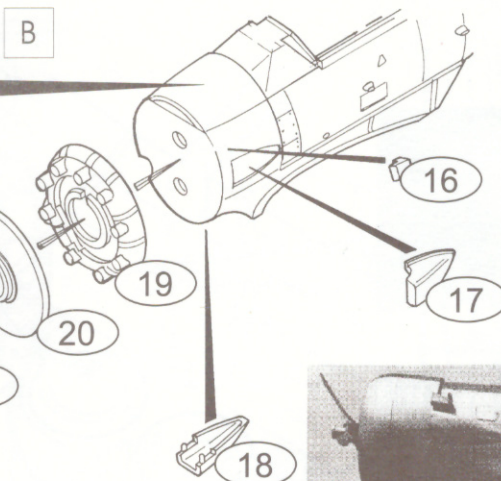

5

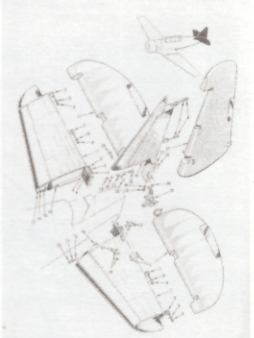
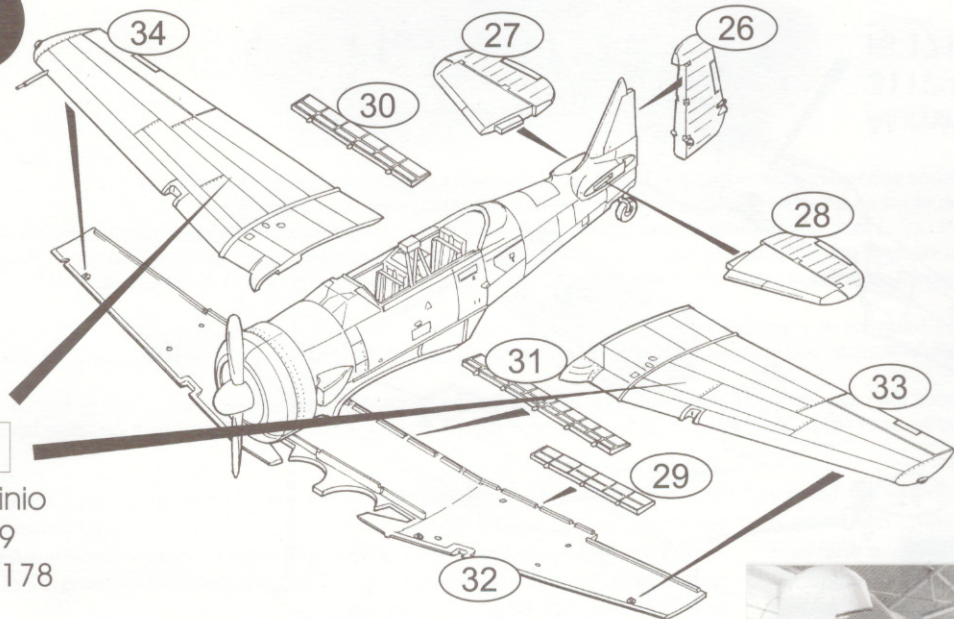

C
 Aluminio
 31199
 FS 17178



Preto Mate
 Matt Black
 Noir Mat
 31302

7

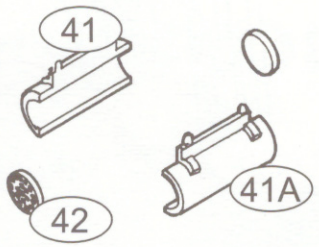
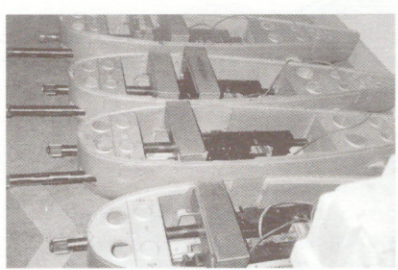
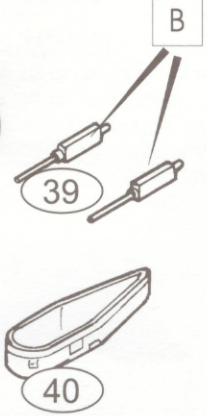

8

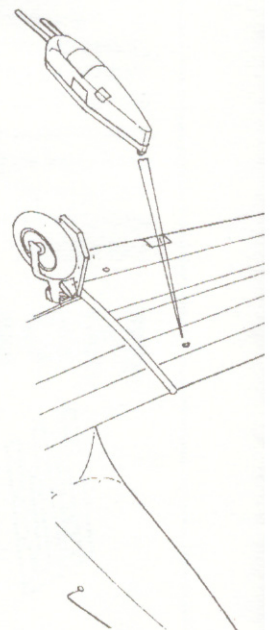

6

Preto Mate
Matt Black
Noir Mat
31302

B

35

36

37

38

Aluminio
31199

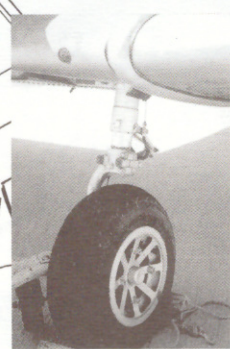

9

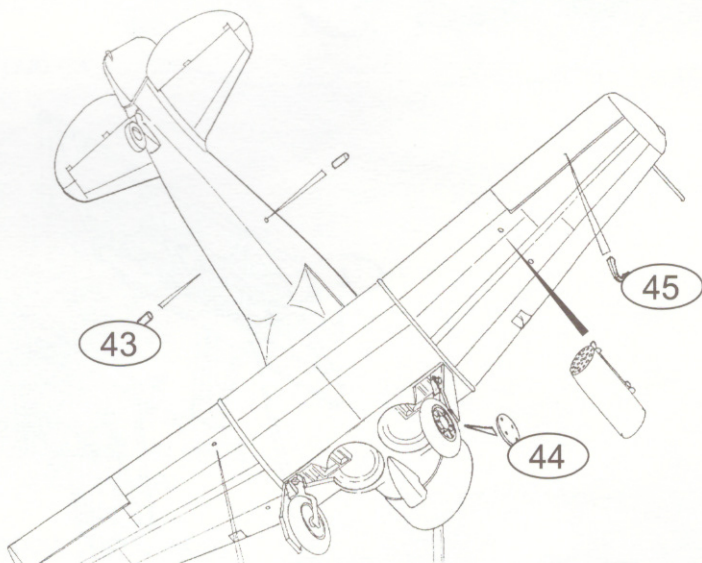
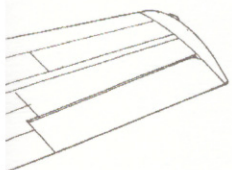

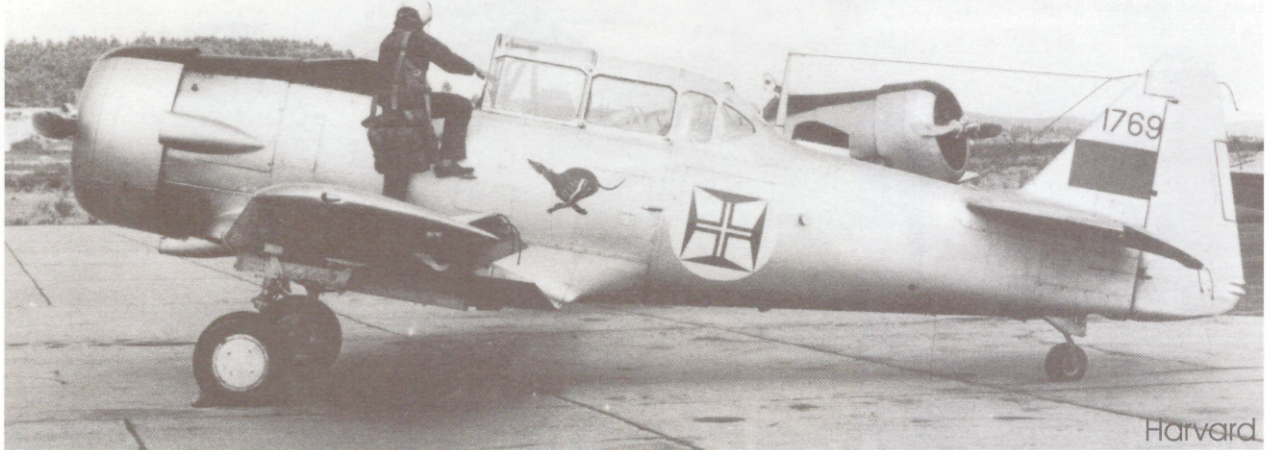

10

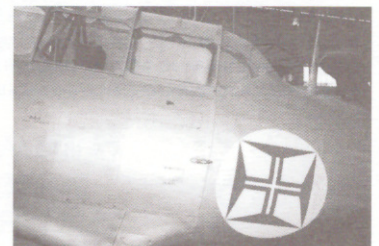
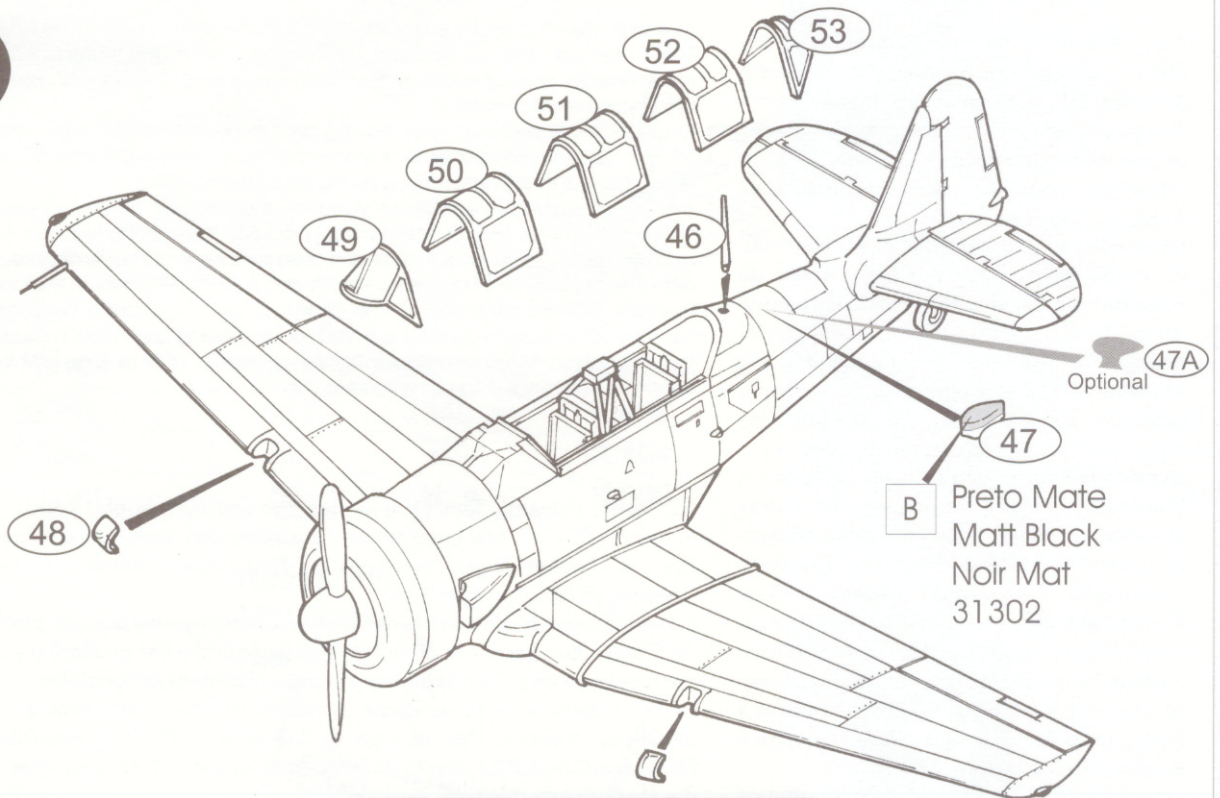

North American T-6G

Decals

Portugal

NORTH AMERICAN T6-G "TEXAN" 1723
FORÇA AÉREA PORTUGUESA; PORTUGUESE AIR FORCE
ANGOLA
OVERALL PAINTING: DULL ALUMINIUM
REVELL 31199; FS 17178

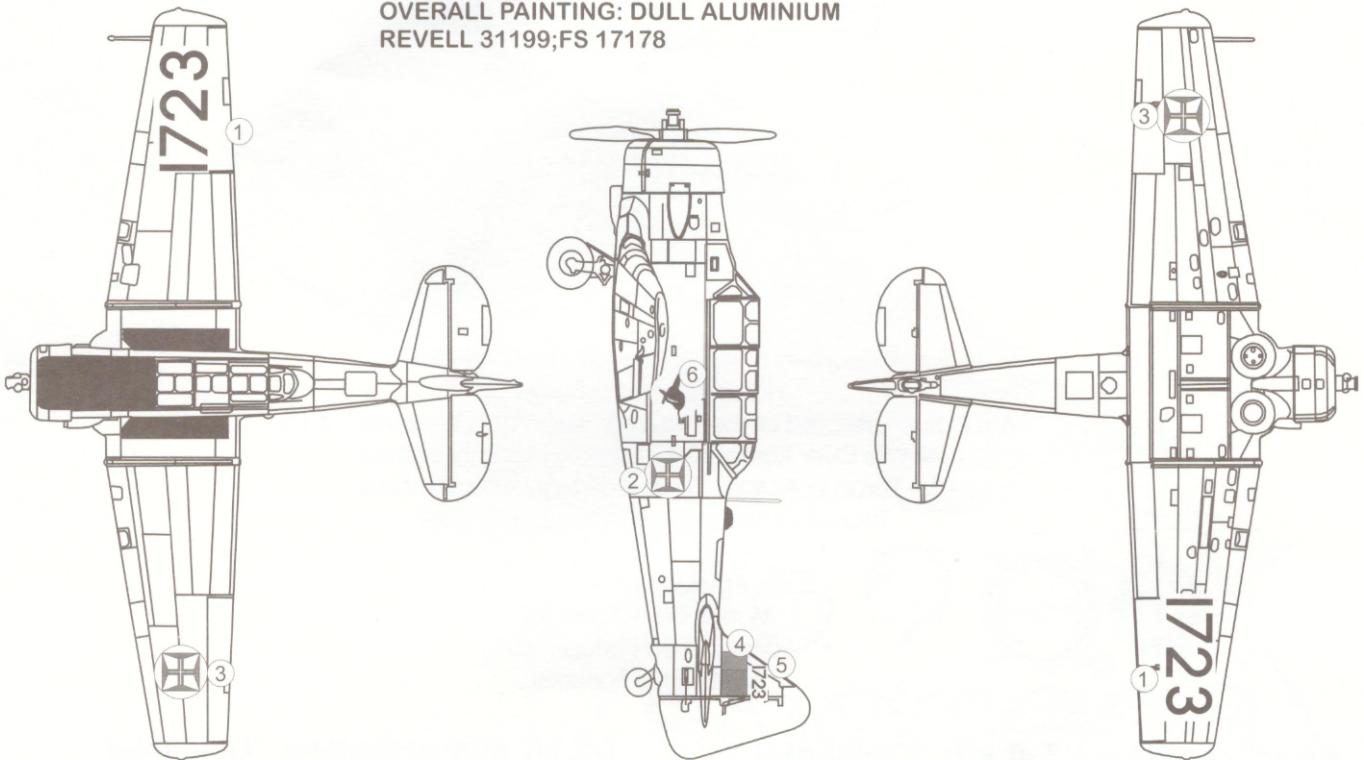

France

NORTH AMERICAN T6-G 149 19 "TOMCAT"
FORÇA AÉREA FRANCESA; ARMÉE DE L'AIR
ARGÉLIA; ALGERIA-I'E.A.L.A. 19/72
OVERALL PAINTING: DULL ALUMINIUM
REVELL 31199 FS 17178

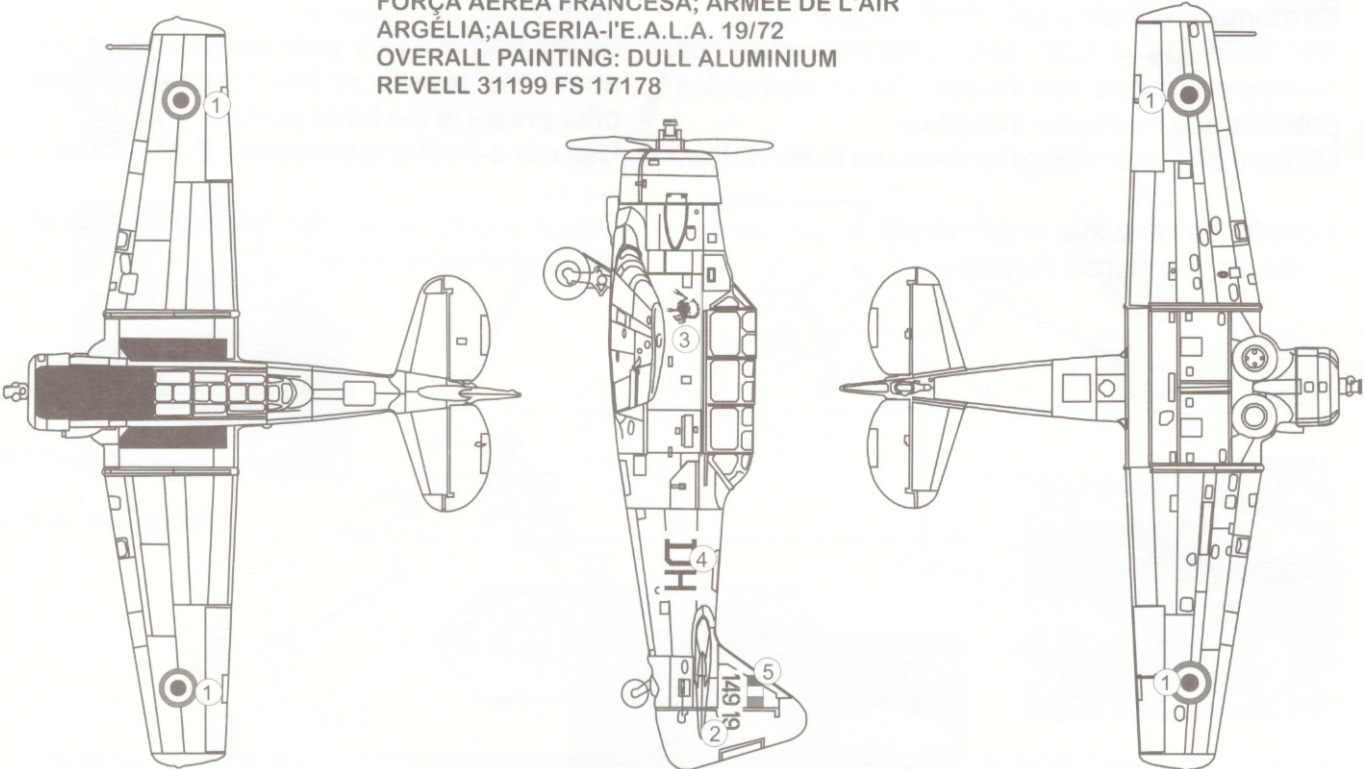

A maior parte dos T-6G da Força Aérea Portuguesa foi adquirida à Armée de l'Air (Francesa) após a Guerra da Argélia
Most of the T-6G aircrafts of the Portuguese Air Force had been used by French Armée de l'Air in Algeria

Documentação

Revistas:

Replic
Scale Aircraft Modelling
QSM
Airfix Magazine
Scale Models International
Scale Aviation Modeller
Air Fan
Mais Alto

Livros

T6 dans la Guerre d'Algerie - Éditions Atlas
Harvard! - Flying Books
T-6 A Pictorial Record of the Harvard, Texan and Wirraway- Air Life
Air War Over Korea - Squadron Signal Publications
T-6 Texan in Action - Squadron Signal Publications
Technical Manual T-6G and LT-6G - USAF

Agradecimentos
Museu do Ar Portugal
Força Aérea Portuguesa
AAM - IPMS Portugal

Concurso anual T-6 kit "Ocidental"

Envie-nos uma boa fotografia do seu T-6 depois de montado e acabado.

No final de cada ano informaremos os concorrentes dos resultados. Serão atribuídos prémios aos melhores trabalhos.

Utilize o nosso e-mail e torne-se um **E-Modeller**

Agradecemos a sua encomenda do primeiro avião da "Ocidental Replicas"

T-6 kit annual Contest "Ocidental"

Send us a good picture of your T-6 kit after assembled and finished.

By the end of every year we will inform you about the results of this contest. We will offer prizes to the best works.

Use our e-mail and become a **E-Modeller**

Thank you for your order of the first aircraft of "Ocidental Replicas"

Nome _____ Name
Morada _____ Address
Telefone / FAX / e-mail _____ Phone /FAX /e-mail



Plasticum Lda. Lugar da Estação, 181 4470 Maia Portugal
Tel: 351-2-9417634 Fax 351-2-9487020

E-mail: molds@ess.pt