

Churchill Mk V

95mm howitzer



British Infantry Tank

**SPECIAL THANKS: Mr. Ossie Orsbourn-UK Vis

The British tank design concept established in 1930s resulting tanks in three very different aspects: light tanks for reconnaissance, cruiser tanks which were fast and mobile and infantry tanks to accompany infantry to help them break through heavily defended areas in the enemy lines.

Although the Matilda's performance was proven in the Battle of France in 1940, yet its small turret made a heavier gun impossible. Furthermore, its limited off-road speed was never considered satisfied.

Designed as the successor of Matilda, a new tank infantry prototype was introduced in November 1940, and the first batch of mass production tanks saw service in June the following year. This series of tanks was named after Winston Churchill, who was appointed First Lord of the Admiralty at that time, due to his contribution to the development of the tank as a weapon.

As an infantry tank, the Churchill features with heavy armours and reliable suspension systems, equipped with 11 bogies each side, dispersing ground pressure. Early version Churchill tanks were criticized its underpowered 2-pounder gun. While the war going, later version Churchill tanks were upgraded with defensive and fire powers. For different purposes, the Churchill tank was used as a platform for various conversions.

The 6-pounder was equipped with Churchill Mk. III and IV, which made them possible to compete with German medium tanks. Based on Mk. IV chassis, the Mk. V equipped with 95mm/L23 howitzer, which is able to launch howitzer and smoke shells to against soft targets. For anti-tank tasks, its shaped charge anti-armour shell is able to penetrate 110 mm homogeneous armour in effective. 241 Churchill Mk. Vs were produced in 1943 and 1944; saw actions in Western Europe theaters.

イギリス陸軍の戦車設計の方針は1930年代に、まったく異なる用途の3種類の戦車によって確立された。すなわち、偵察用の軽戦車、機動性と速度を重視した巡航戦車、そして歩兵に同行し、彼らの敵陣突破を助ける歩兵戦車の3種であった。

1940年のフランス戦において、マチルダ歩兵戦車の問題点が浮き彫りになった。小さな砲塔は大口径の火砲の搭載ができず、さらに路外速度の低さは到底納得できるものではなかったのである。

マチルダ戦車の後継となる新型歩兵戦車の試作型は、1940年11月に完成し、最初の量産型は、翌年の6月に配備がはじまった。この新型歩兵戦車シリーズは、海軍大臣時代に戦車を兵器として開発することに貢献したウィンストン・チャーチルにちなんで、チャーチル歩兵戦車と名づけられた。

歩兵戦車としてのチャーチル戦車の特徴は、重装甲と信頼性の高いサスペンション(両側面の11個のボギーで接地圧を分散させる)であった。初期生産型のチャーチル戦車は、搭載した2ポンド砲の威力不足が問題視されていた。戦争の推移にともない、後期の生産型では、防御力と火力の向上が図られることとなった。また、異なる用途のベース車両として、チャーチル戦車は、さまざまな改装型が造られたのである。

チャーチルMk. III、Mk. IVは6ポンド砲を装備し、ドイツ軍の中戦車に対抗することが可能となった。Mk. Vは、Mk. IVの車体をベースに95mm/L23榴弾砲を装備、軟目標に対して榴弾や煙幕弾を発射することが可能であった。対戦車については、徹甲榴弾の使用により、110mm厚の均質装甲を貫通することが可能であった。1943年と44年に合計241輛のチャーチルMk. Vが生産され、西部ヨーロッパ戦線で活躍したのだった。

在1930年代，英國的戰車運用理論中確立了戰車的三種截然不同角色，包括了執行偵查任務的輕戰車、能夠快速突破擴大戰果的巡航戰車，與伴隨步兵能提供步兵火力支援，並清除障礙與工事的步兵戰車。

經過了1940年的法國戰役後，儘管參與戰役的Matilda步兵戰車面對德國戰車有著傑出的表現，但過小的砲塔環限制了將來提升火炮口徑可能，另外它過於緩慢的越野性能也未能讓人滿意。因此英國政府委託設計一種新的步兵戰車用來取代Matilda步兵戰車。1940年的11月新型步兵戰車的試作車完成，1941年6月第一批量產車進入陸軍服役，由於當時的英國首相邱吉爾在擔任海軍大臣期間對戰車這種新武器開發的大力支持，為表彰他的貢獻，因此新的步兵戰車遂命以邱吉爾之名。

邱吉爾步兵戰車延續著步兵戰車既有的特點，有著厚重的裝甲與可靠的懸吊系統，車身兩側每側均有11組承載輪以分散接地壓。早期的邱吉爾步兵戰車搭載的2磅砲有著火力不足毛病，隨著戰事的推移，後期的邱吉爾戰車陸續在防禦力與火力上進行了提升。又為了執行各種特殊任務的需要，因此邱吉爾戰車存在著許多不同的改進型及特別用途改裝型。

邱吉爾戰車發展至Mk.III/IV型時，配備了6磅主砲，使之擁有與德軍中型戰車周旋的實力。隨後的Mk.V型，是以Mk.IV的車體為基礎，在修改後的砲塔上搭載了95mm/L 23的榴彈砲，面對軟性目標能夠發射榴彈與煙幕彈。另在反裝甲的任務中，採用錐形裝藥的破甲榴彈能在有效射程內貫穿110mm厚的均質裝甲。邱吉爾步兵戰車Mk.V型在1943~1944年之間共生產了241輛，並參與了西歐戰場的戰事。

Illustration: 圖示說明



Method For Applying Decals:

1. Clean Model Surface With Wet Cloth.
2. Cut Out Of Decal Sheet And Dip Them In Water For 15 Seconds.
3. Place it on proper position on model.
4. Slide off base paper leaving decals On Model With Wet Finger Tip.
5. Move Decals To Exact Position, Push Out Excess Water Under Decal With Soft Cotton Cloth.
6. When Decals Get Dry Then Complete.

水貼紙使用說明:

1. 將模型表面擦乾淨
2. 將貼紙剪下泡入清水中約15秒
3. 將泡濕之貼紙取出置於欲貼處旁
4. 用指尖輕推貼紙表面使其滑出底紙
5. 將貼紙調整至適當位置並輕擦拭水份
6. 待其自然乾燥後即完成

Color list: 塗料表

Color	Brand	Gunze Sangyo			Humbrol	Revell	Life Color
		Hobby Color	Mr. Color	Mr. Color Spray			
Khaki green	卡其綠	H-80	C-54				
Sandy Yellow	沙黃	H-66	C-119		168	UA020	
Steel	黑鐵	H-18	C-28	J-28	53	91	LC76
Tire black	輪胎黑	H-77	C-33+C-62		85	302	LC02
Red	紅	H-3	C-3	J-3	19	31	LC56
Flat white	消光白	H-11	C-62	J-62	34	05	LC01
Red brown	紅褐	H-47	C-41	J-44	160	383	UA085
Brass	黃銅	H-9	C-9	J-9	54	92	LC75
Wood brown	木棕	H-37	C-43	J-43	10	81	UA085/ UA125
Olive drab(2)	橄欖綠	H-78	C-38	J-38	66	46	UA106

Churchill Infantry Tank

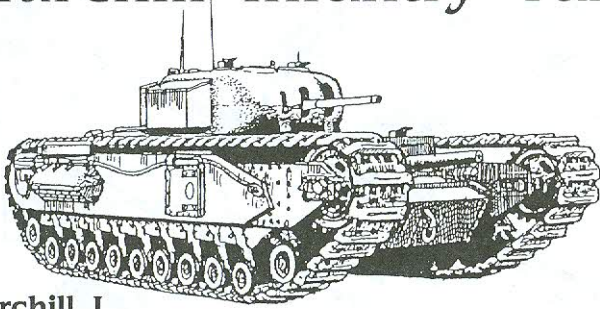

Churchill I
2-pdr gun x 1
3 inch howitzer x 1

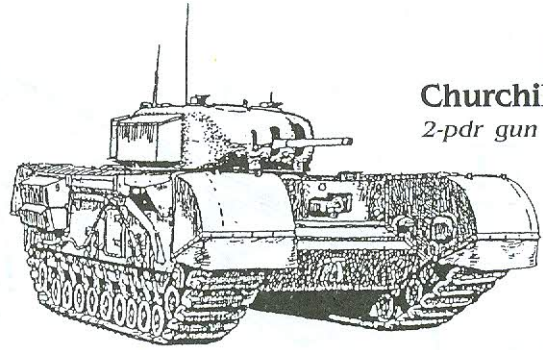

Churchill II
2-pdr gun x 1

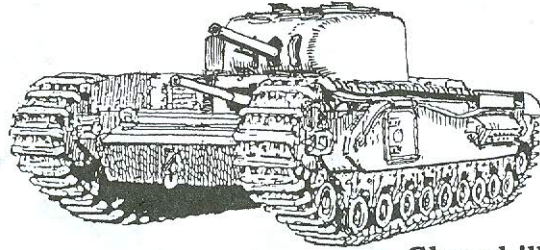

Churchill II CS
3 inch howitzer x 1
2-pdr gun x 1

**3 inch howitzer in turret, 2-pdr in hull. Few built.

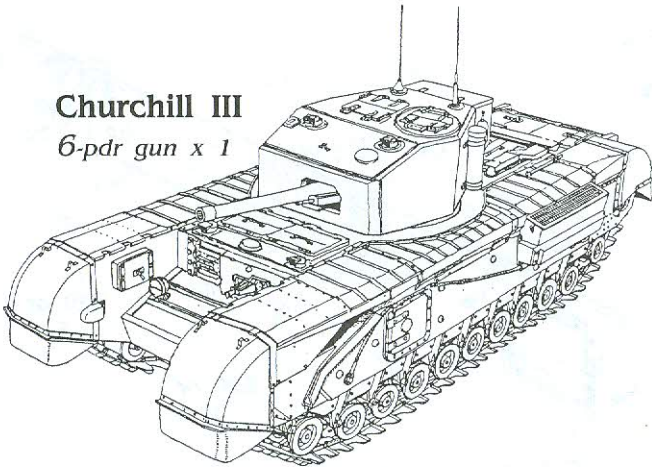

Churchill III
6-pdr gun x 1

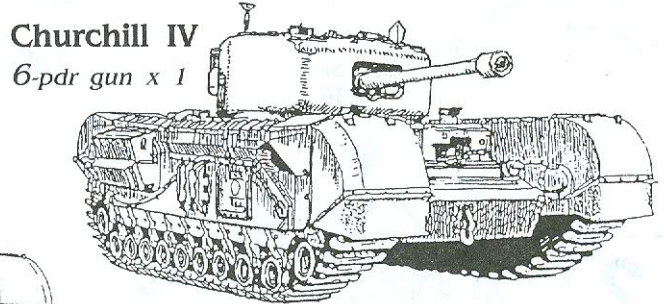

Churchill IV
6-pdr gun x 1

Box Section Spudded

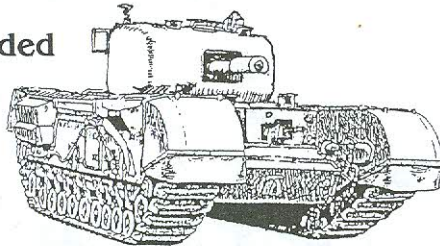
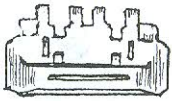

Churchill V
95mm howitzer x 1



Webbed & Studded

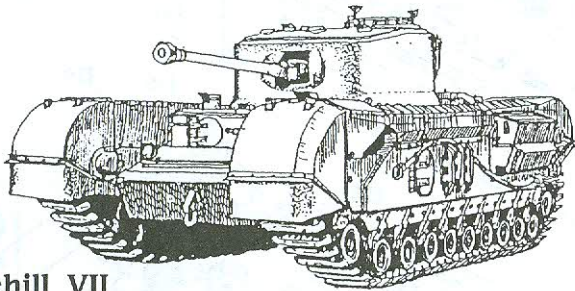

Churchill VII
75mm gun x 1

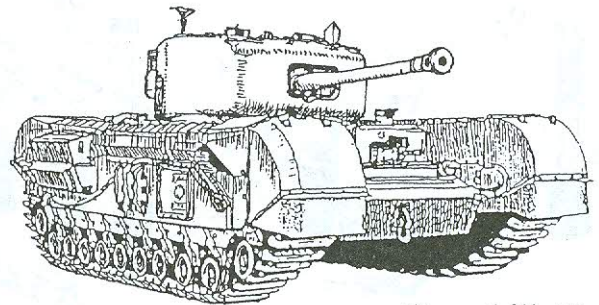

Churchill VI
75mm gun x 1

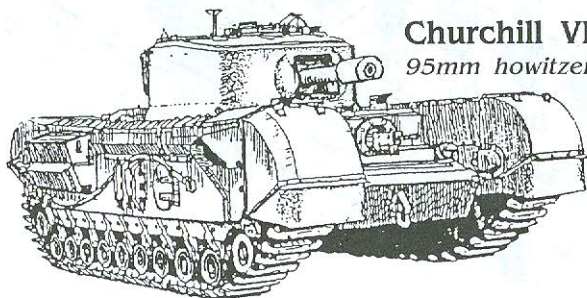

Churchill VIII
95mm howitzer x 1

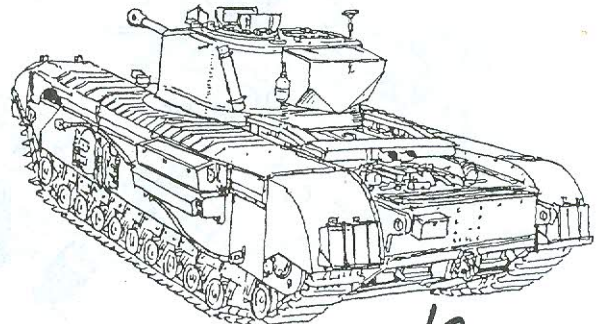

Shin. Ueda

上田 信

1

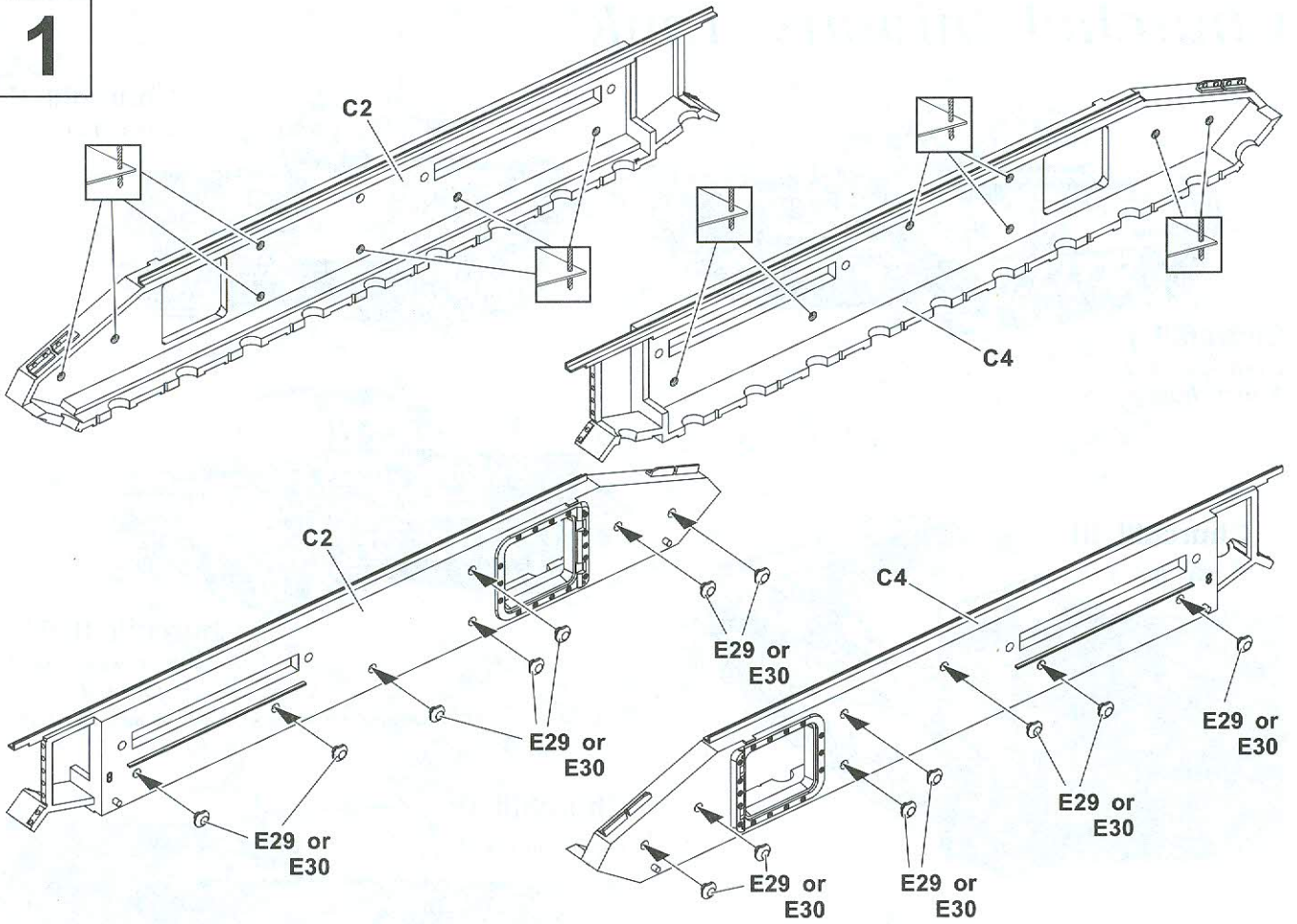

2

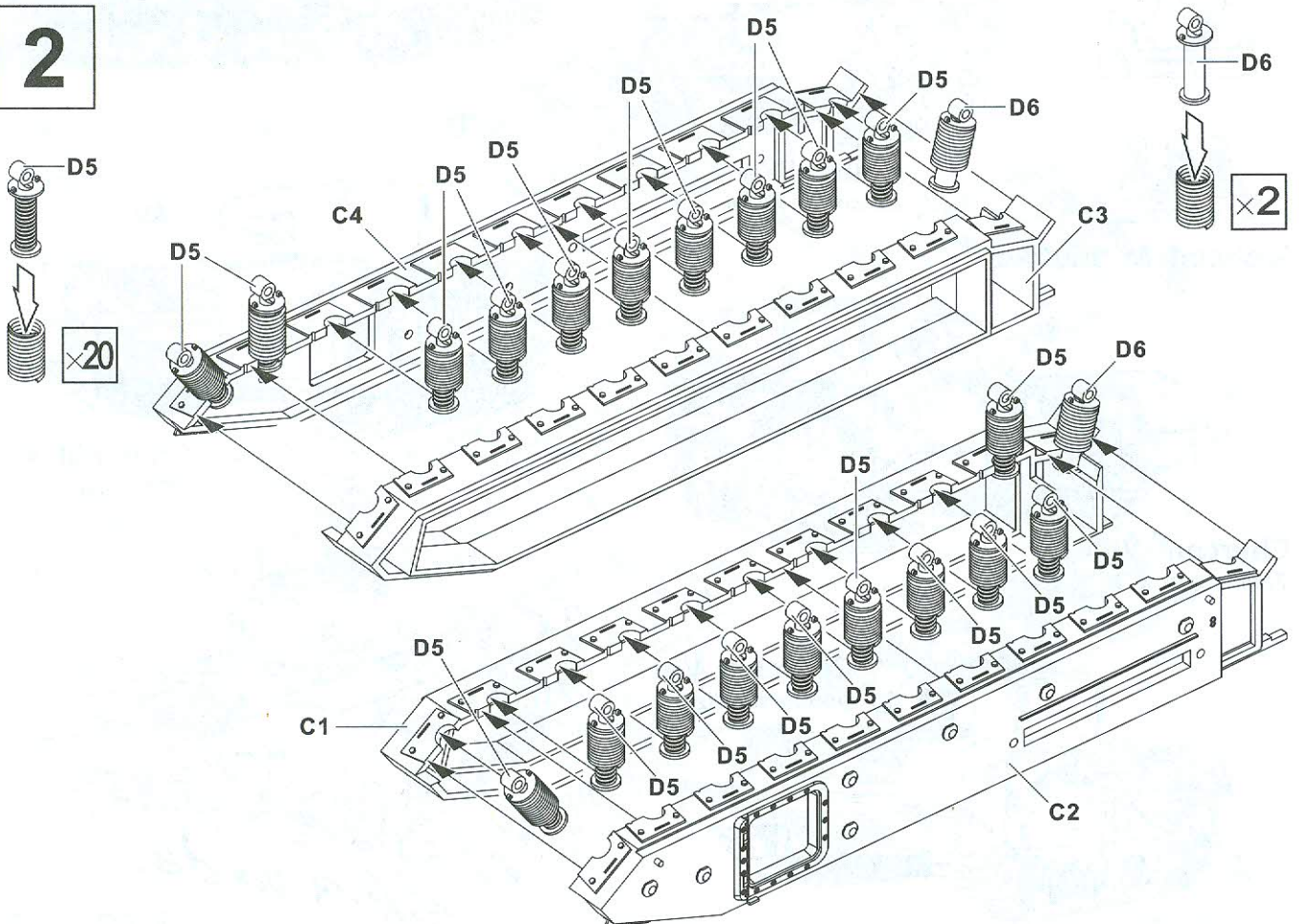

3

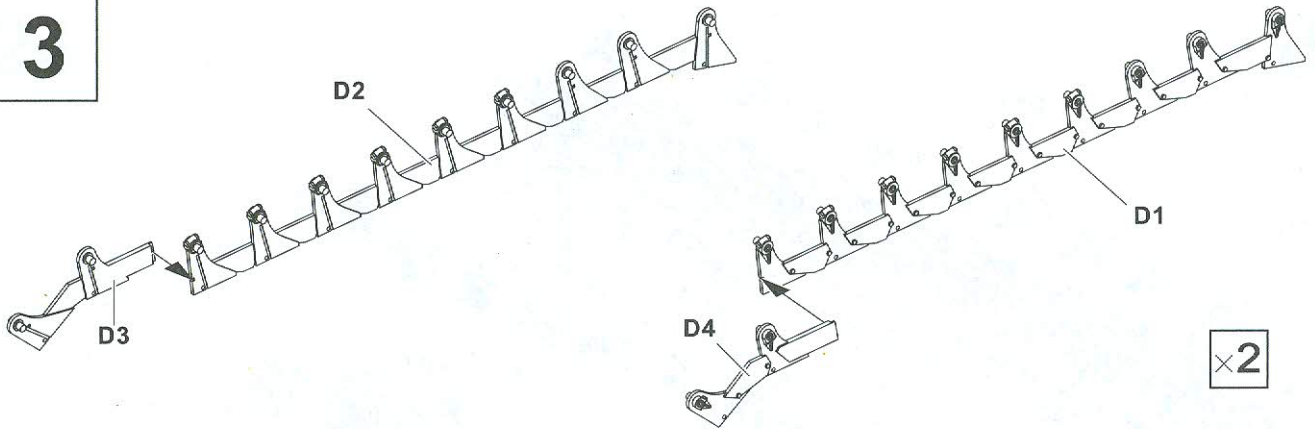

4

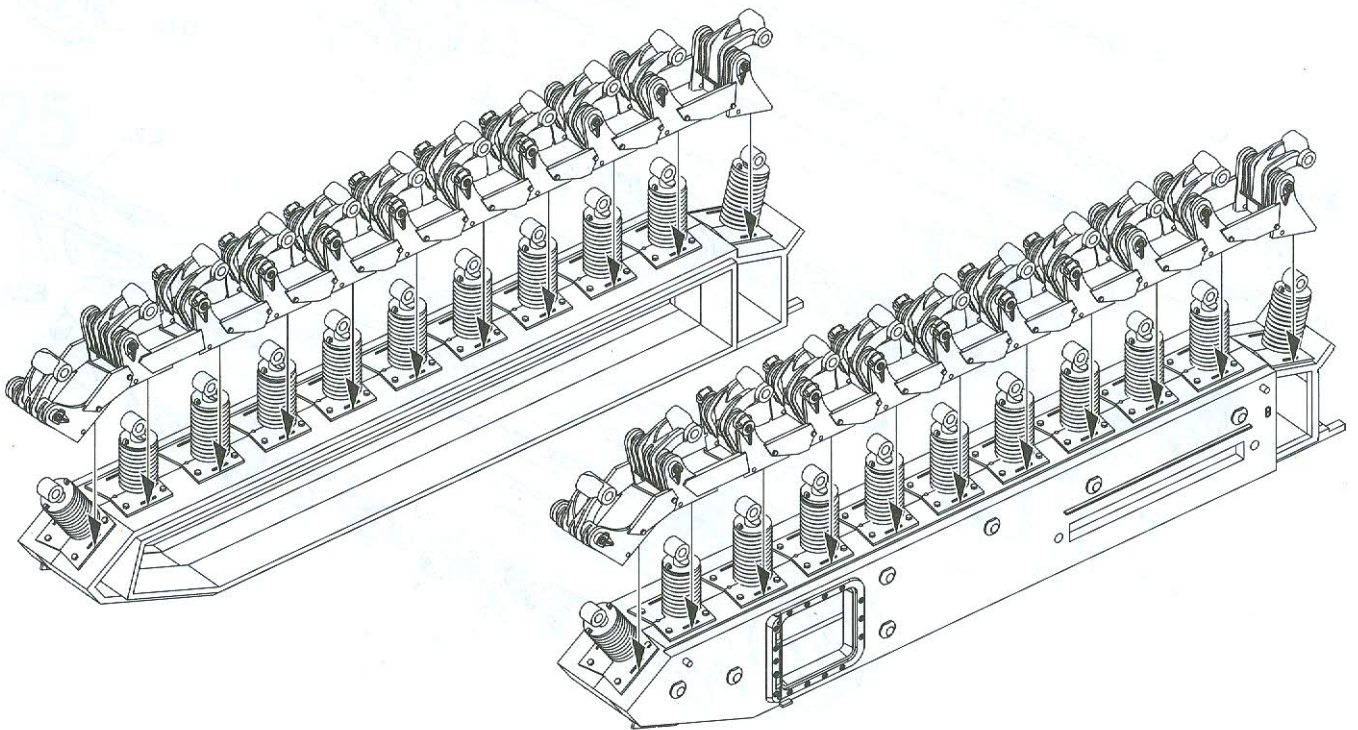
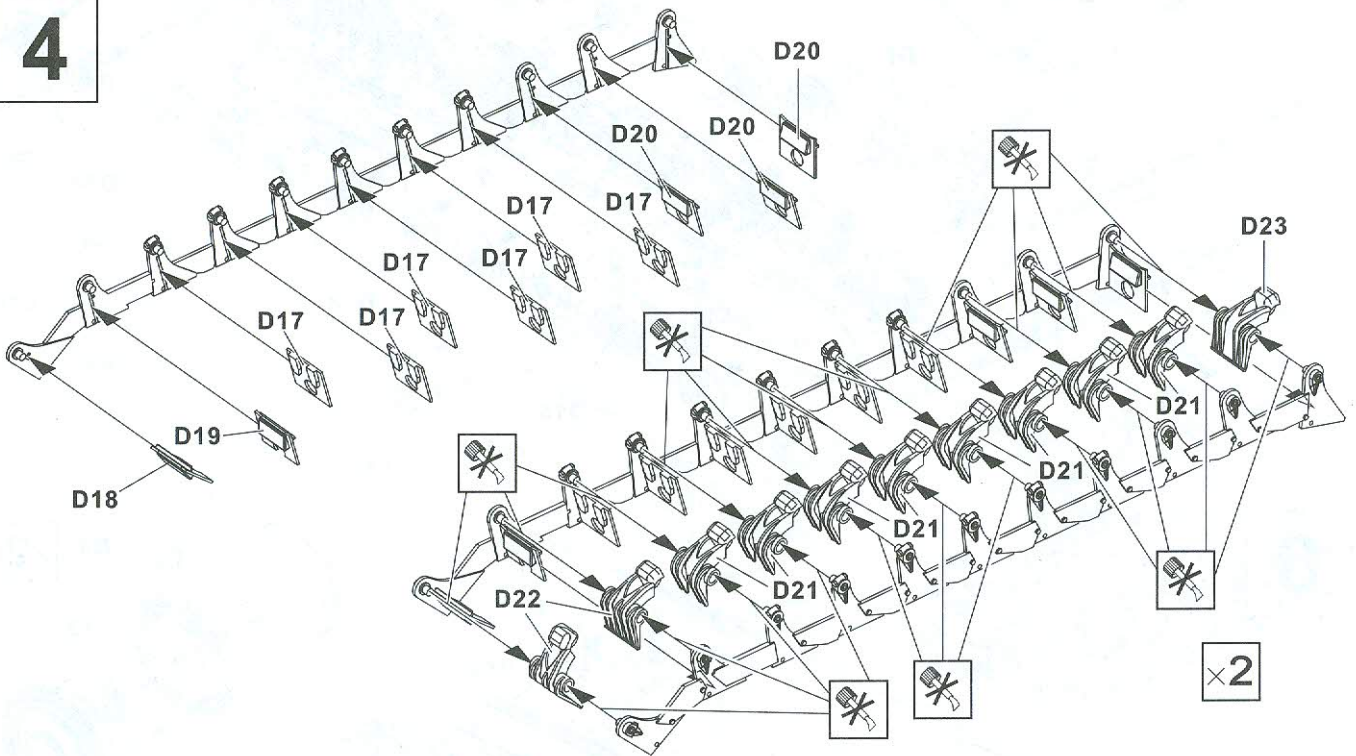

5

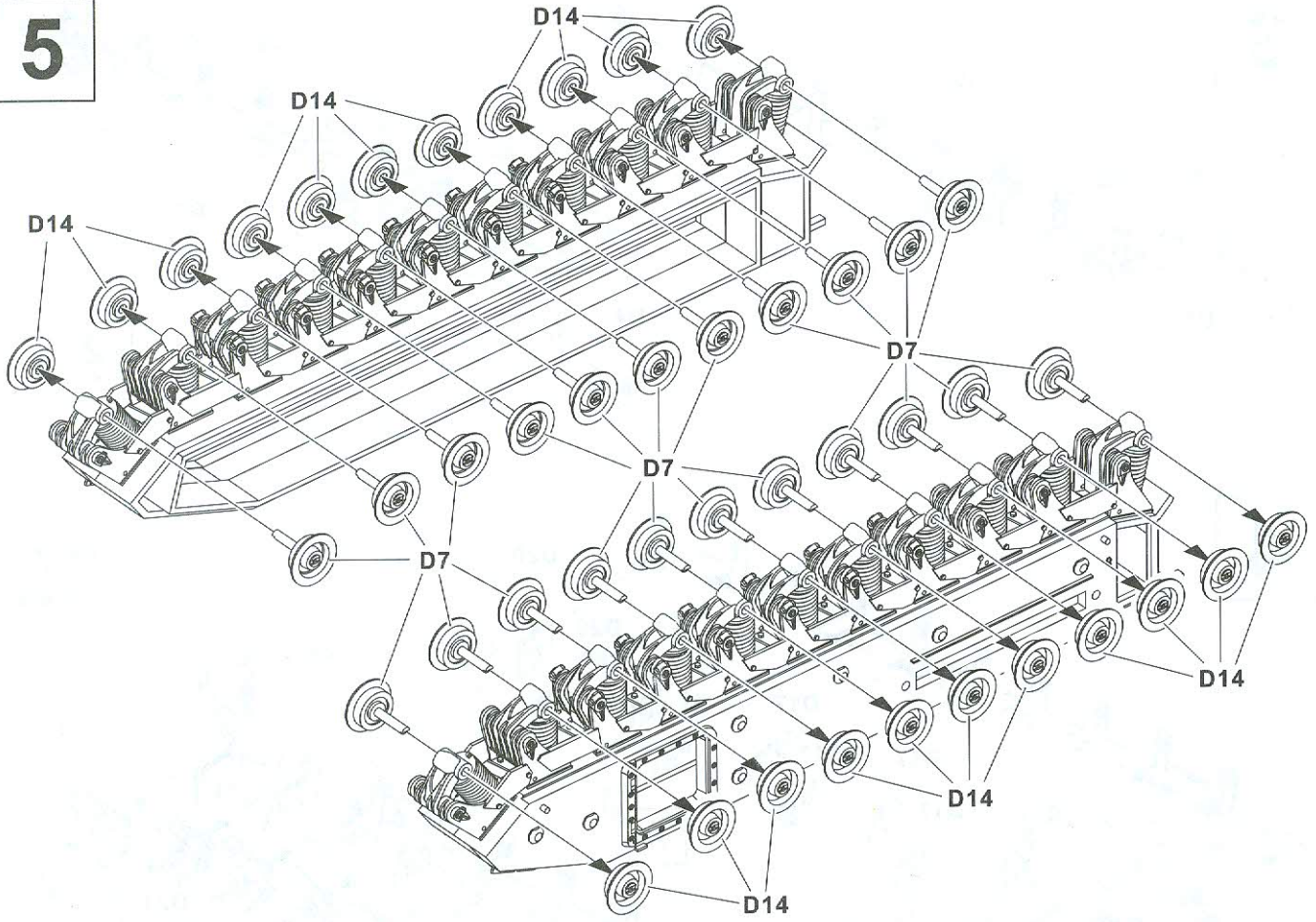

6

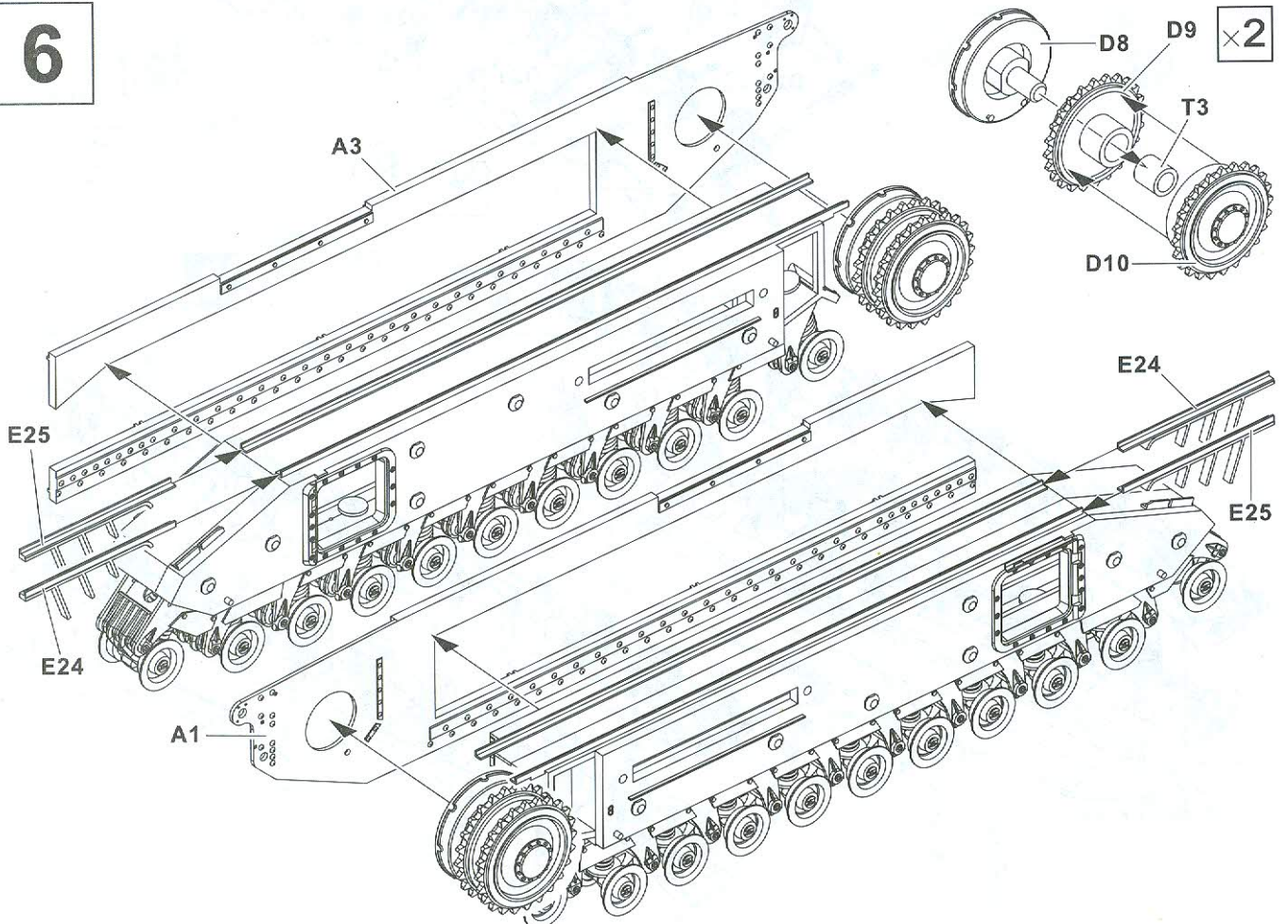

7

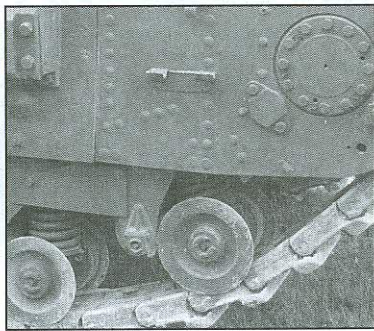
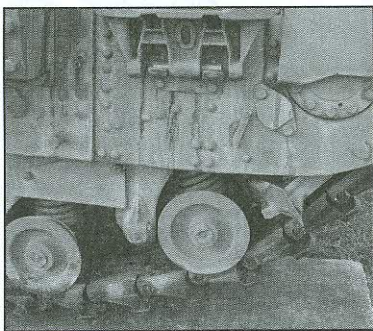
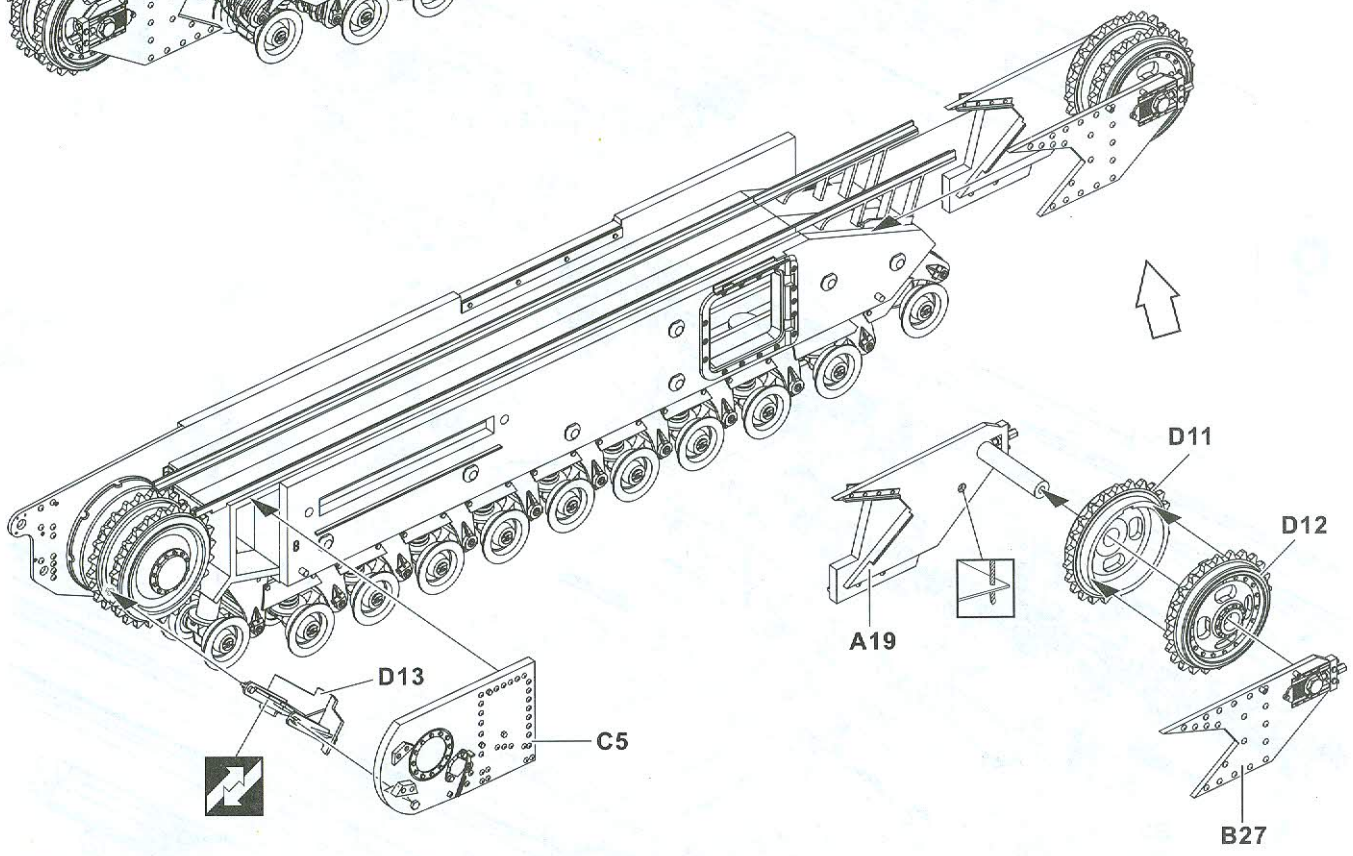
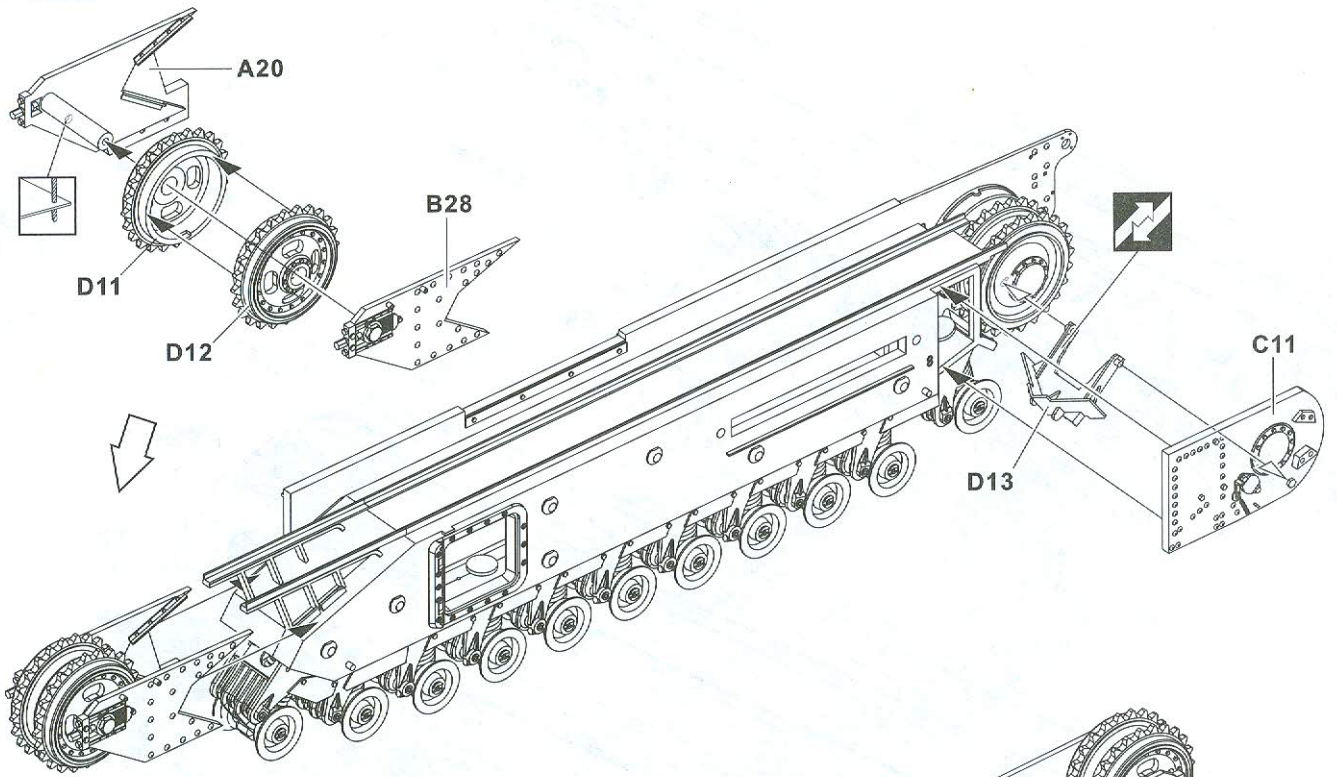

8

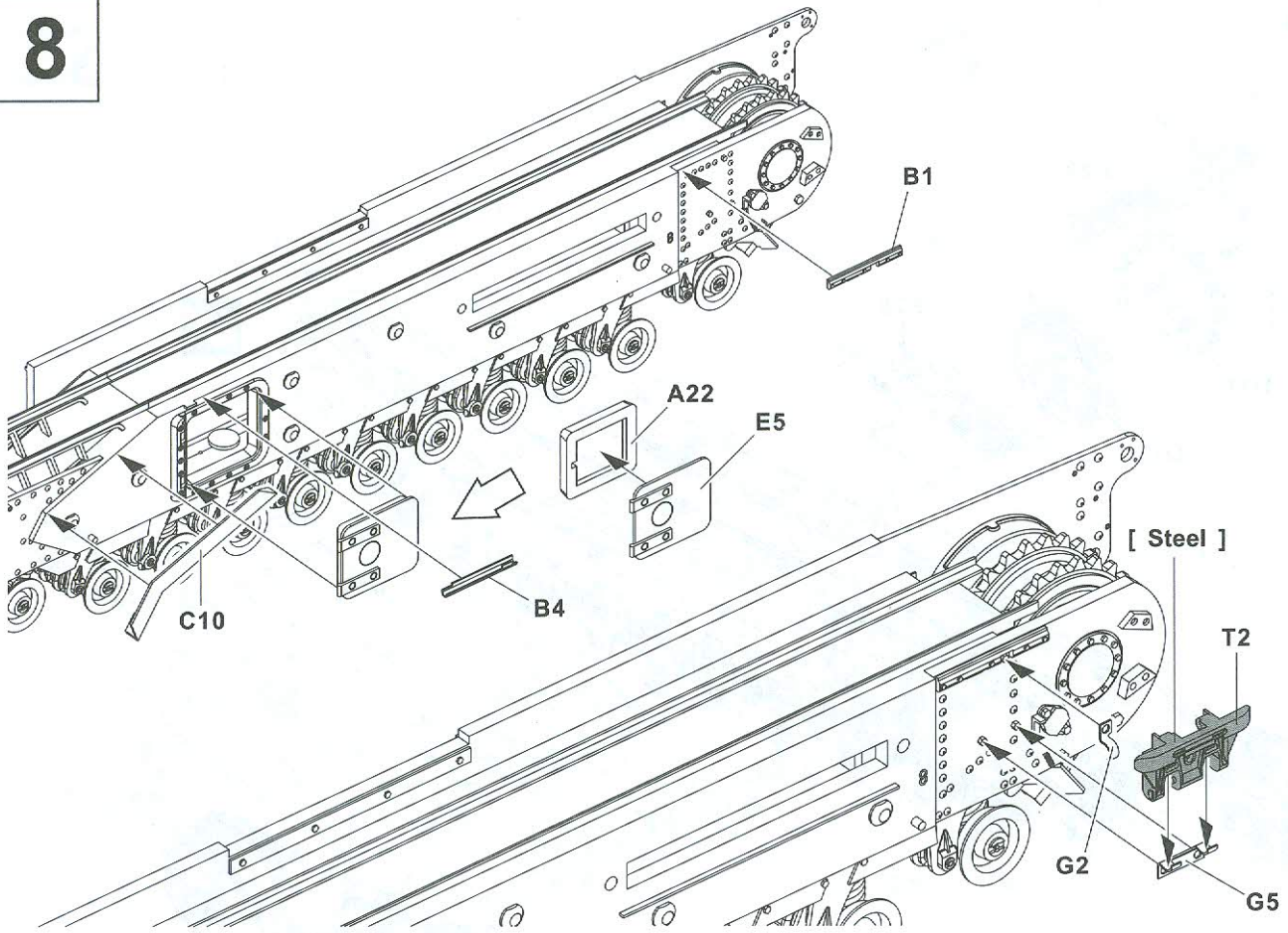

9

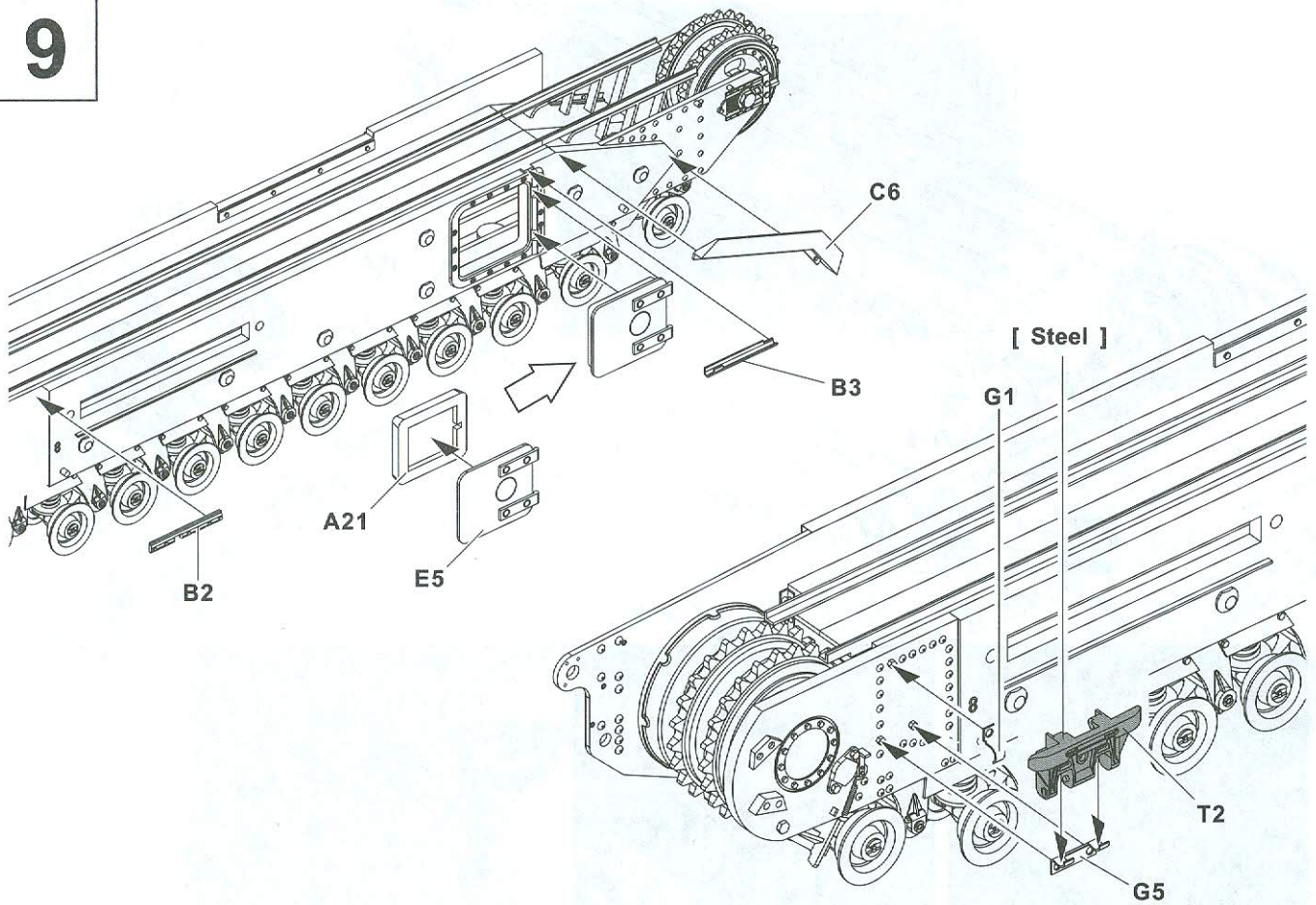

10

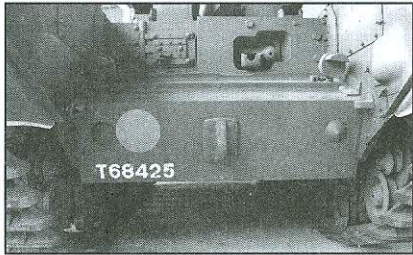
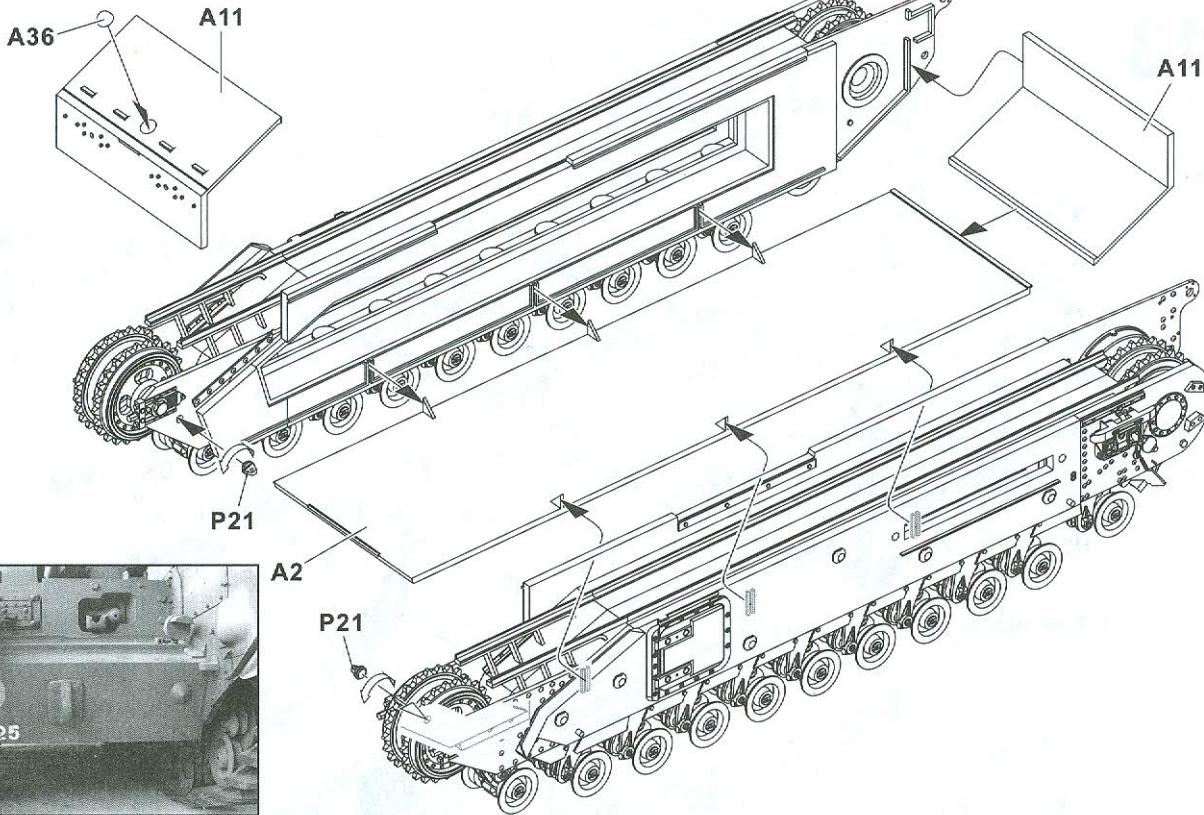

11

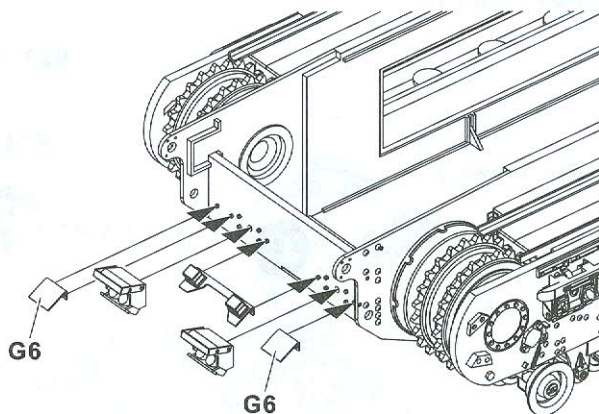
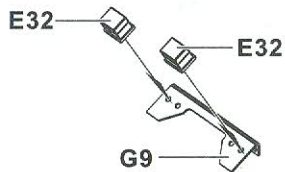
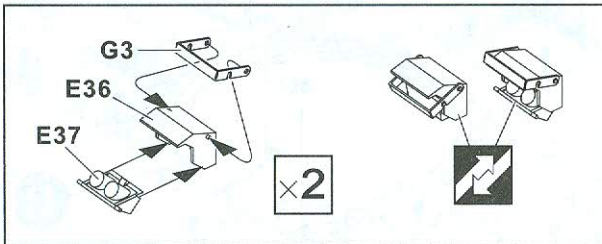

12

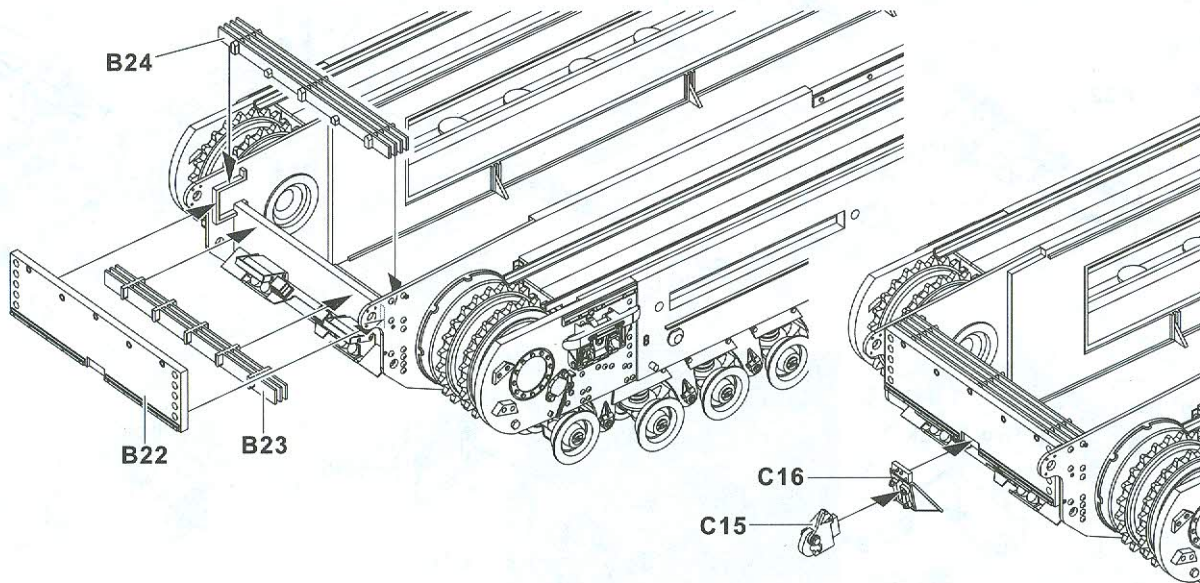

13

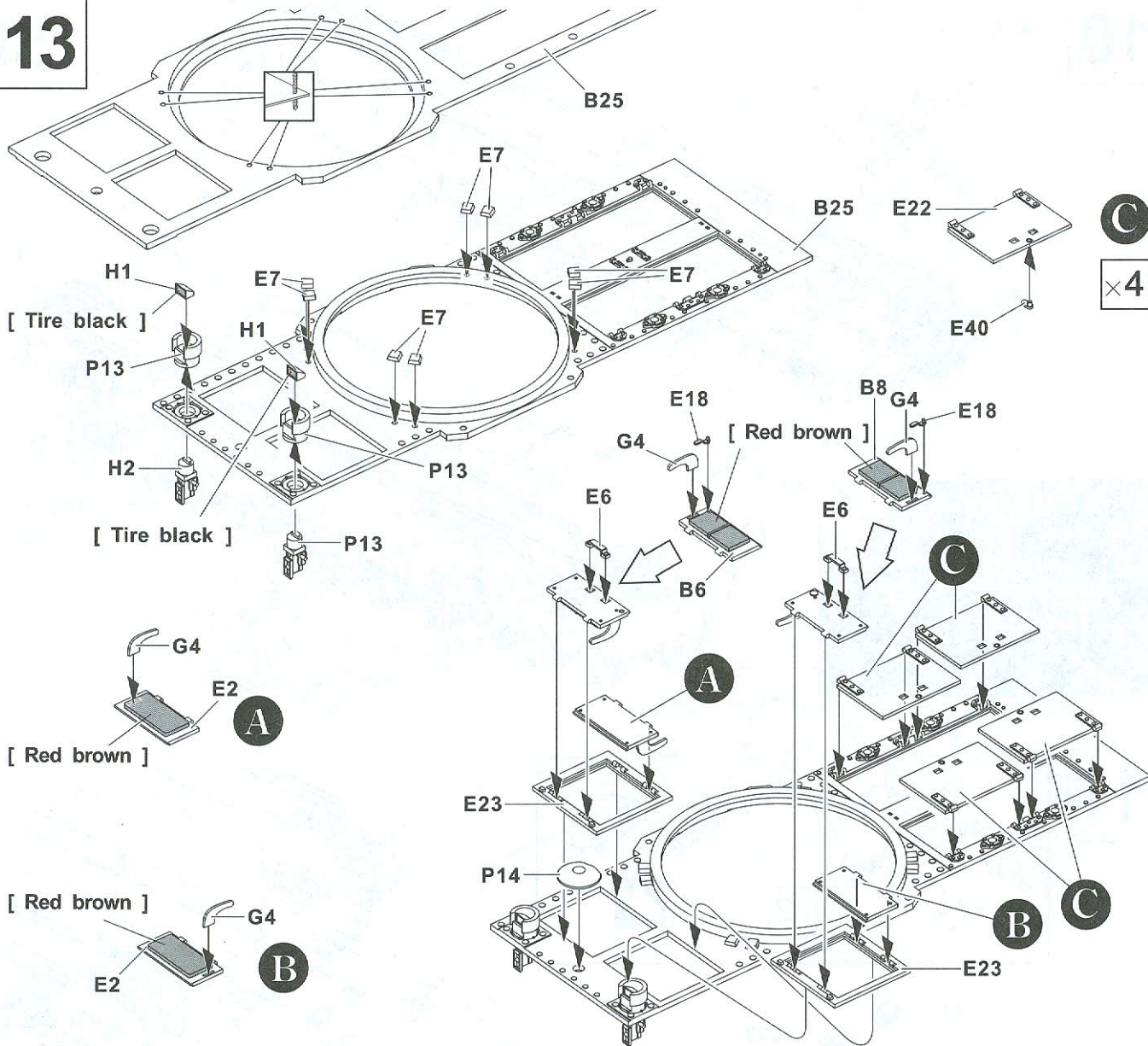

14

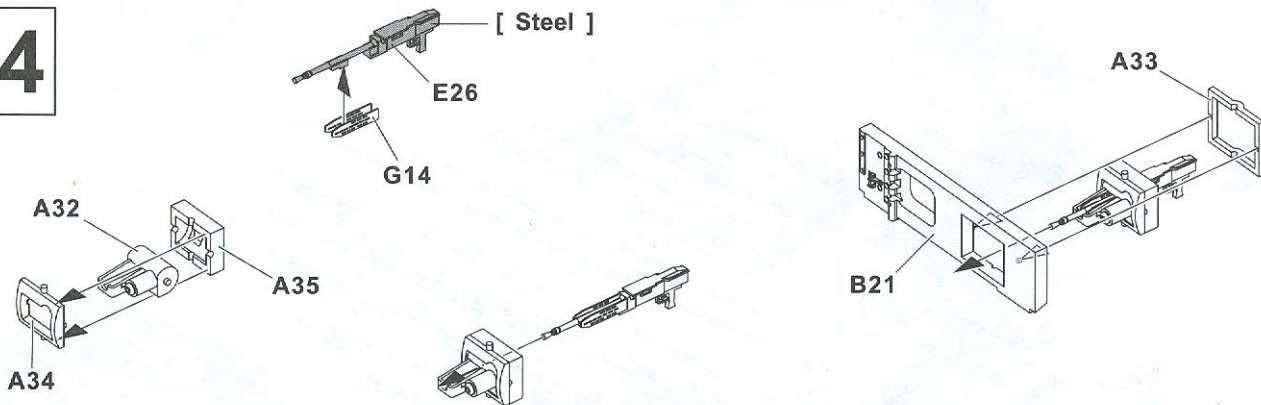

15

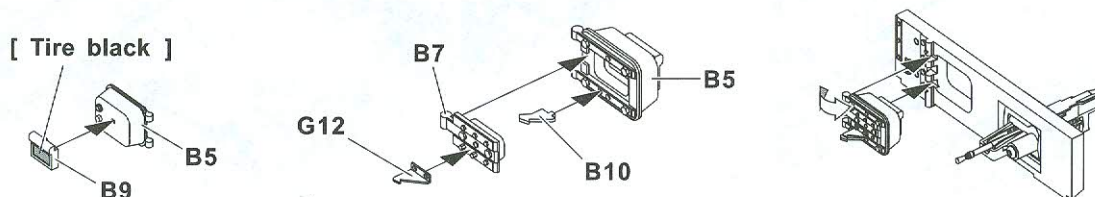

16

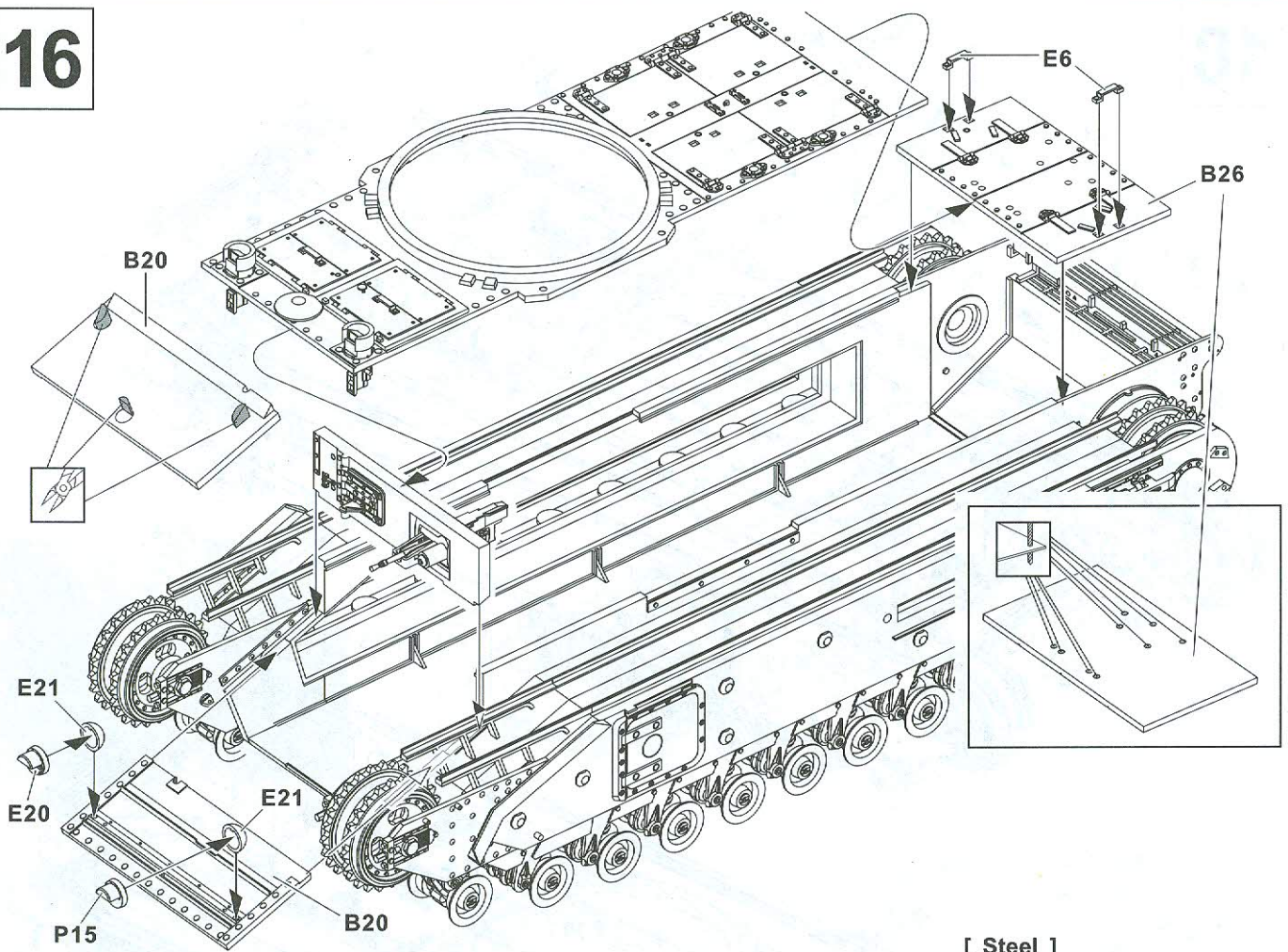

17

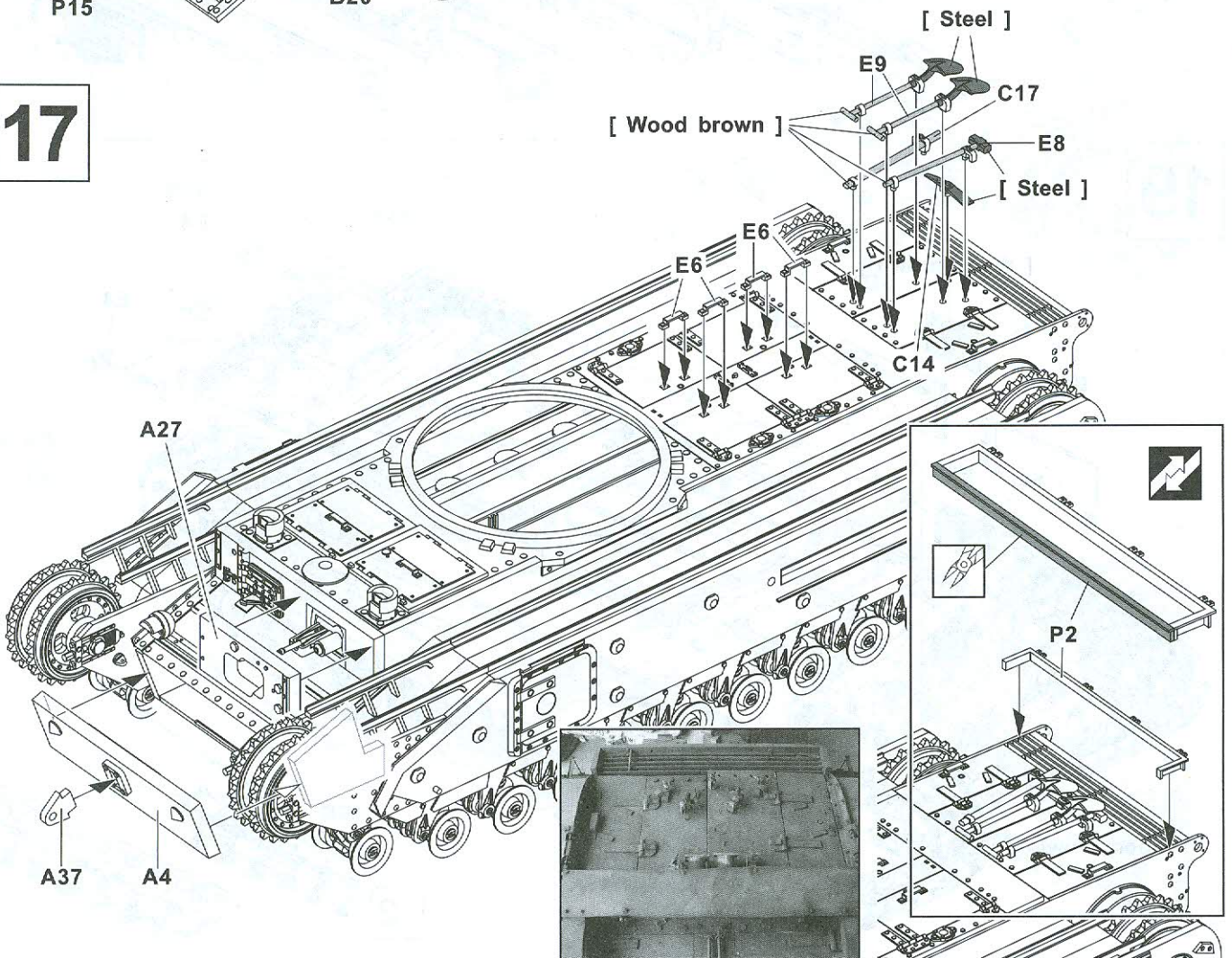

18

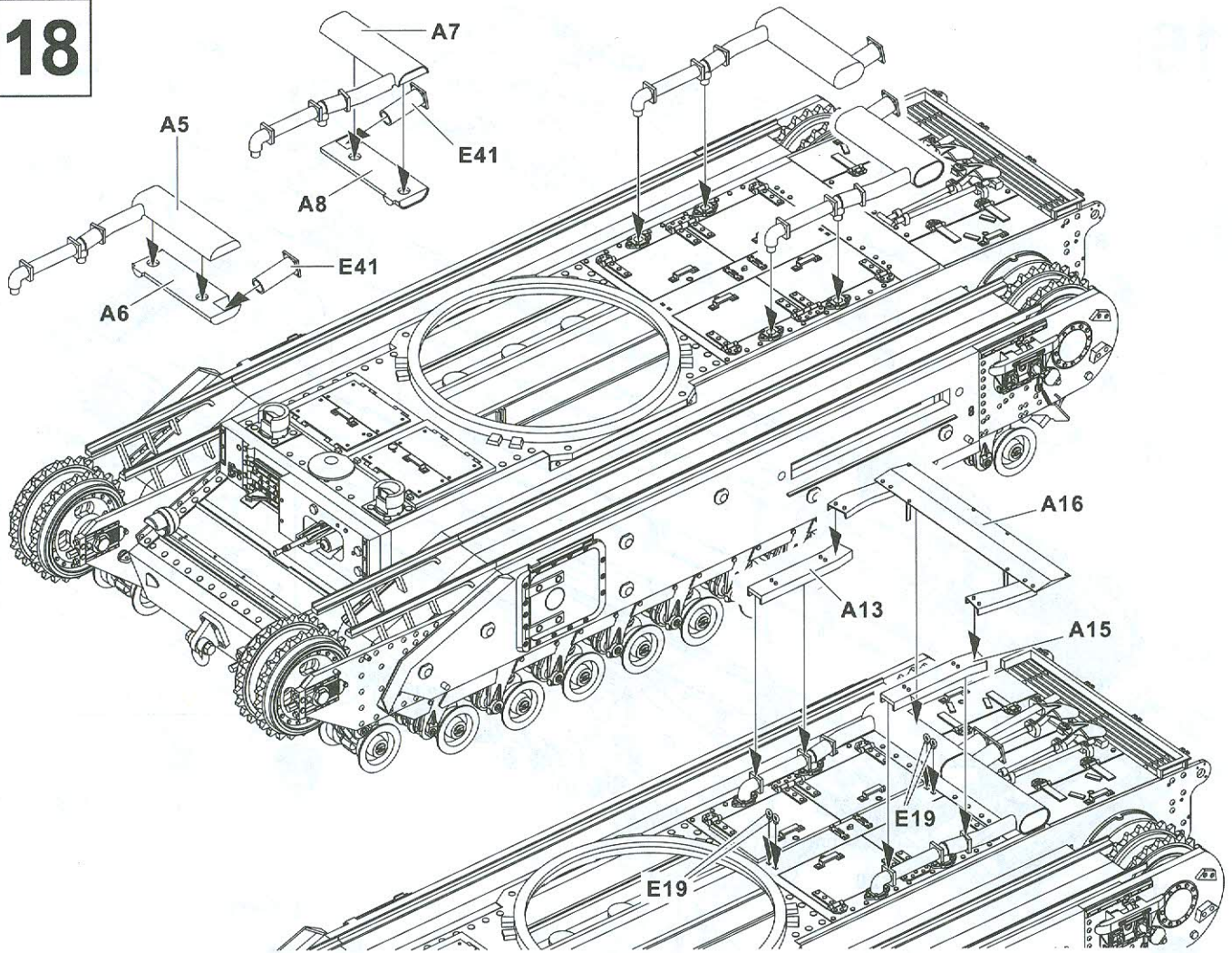

19

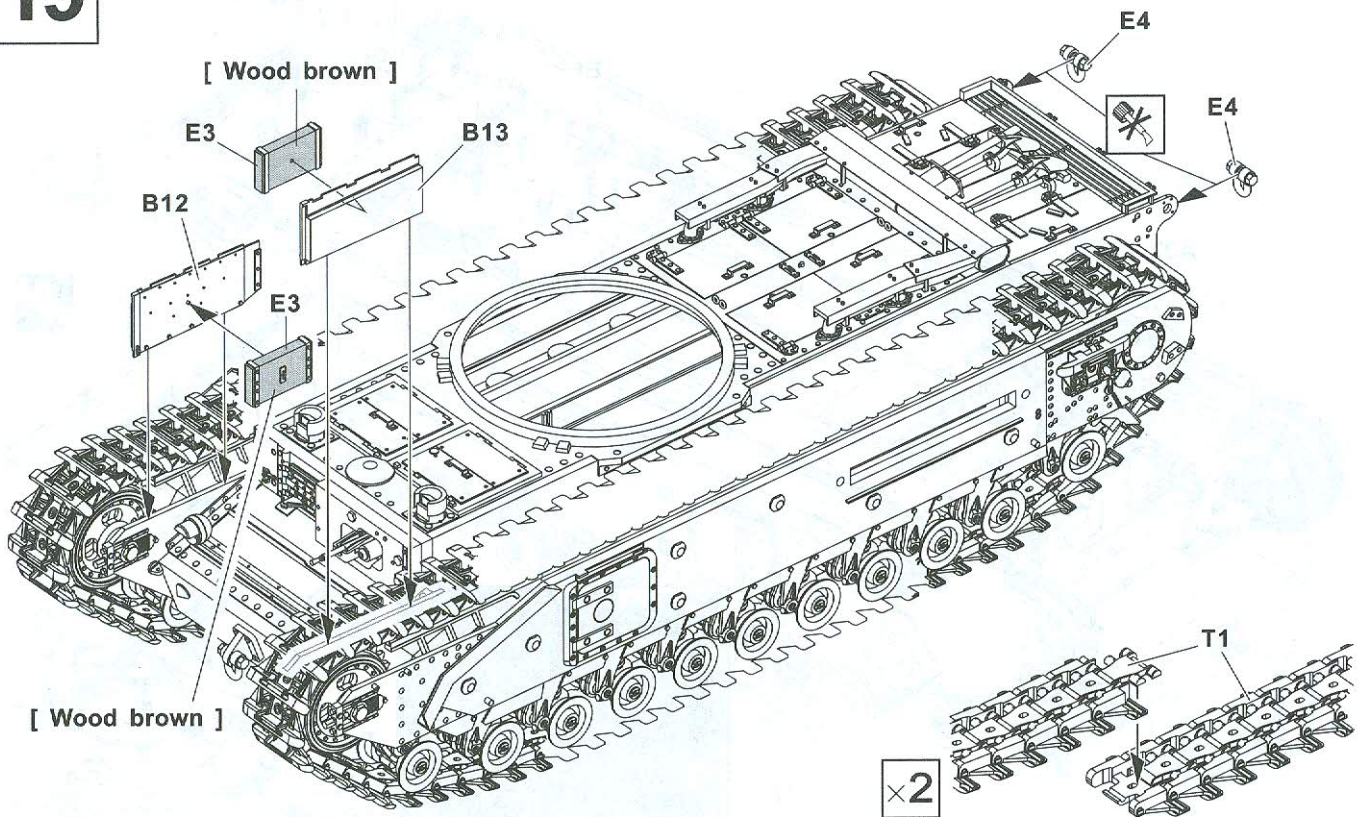

20

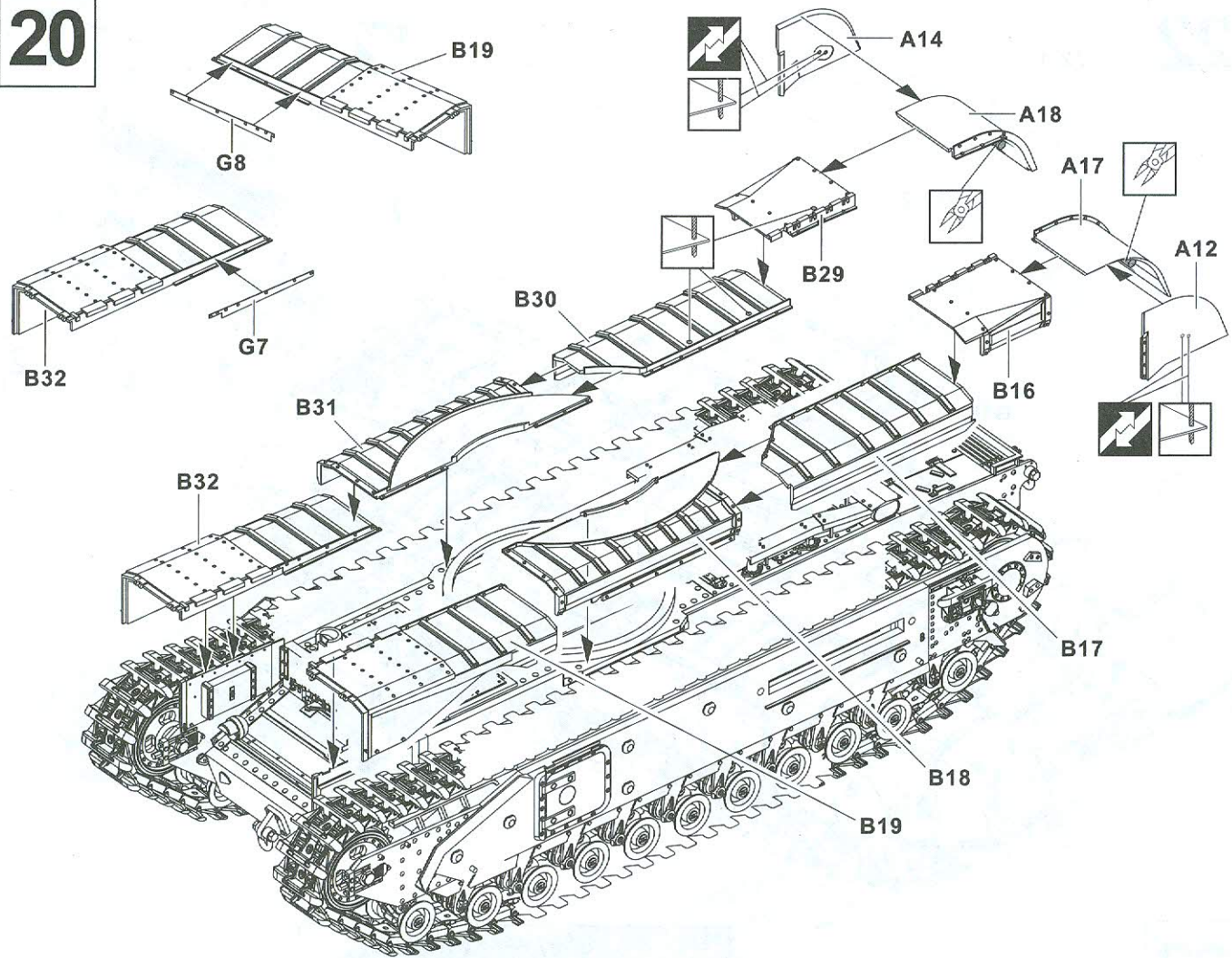

21

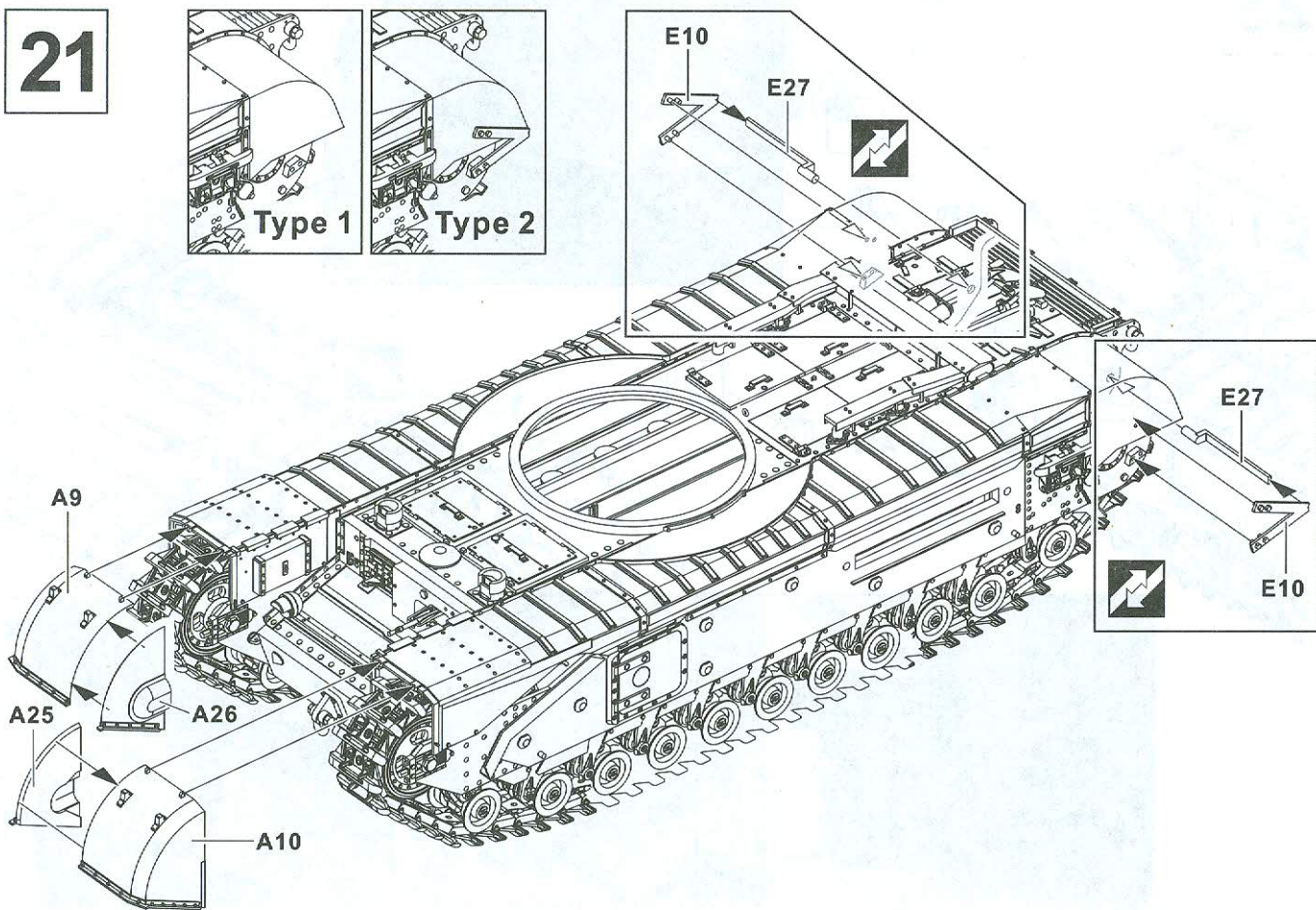

22

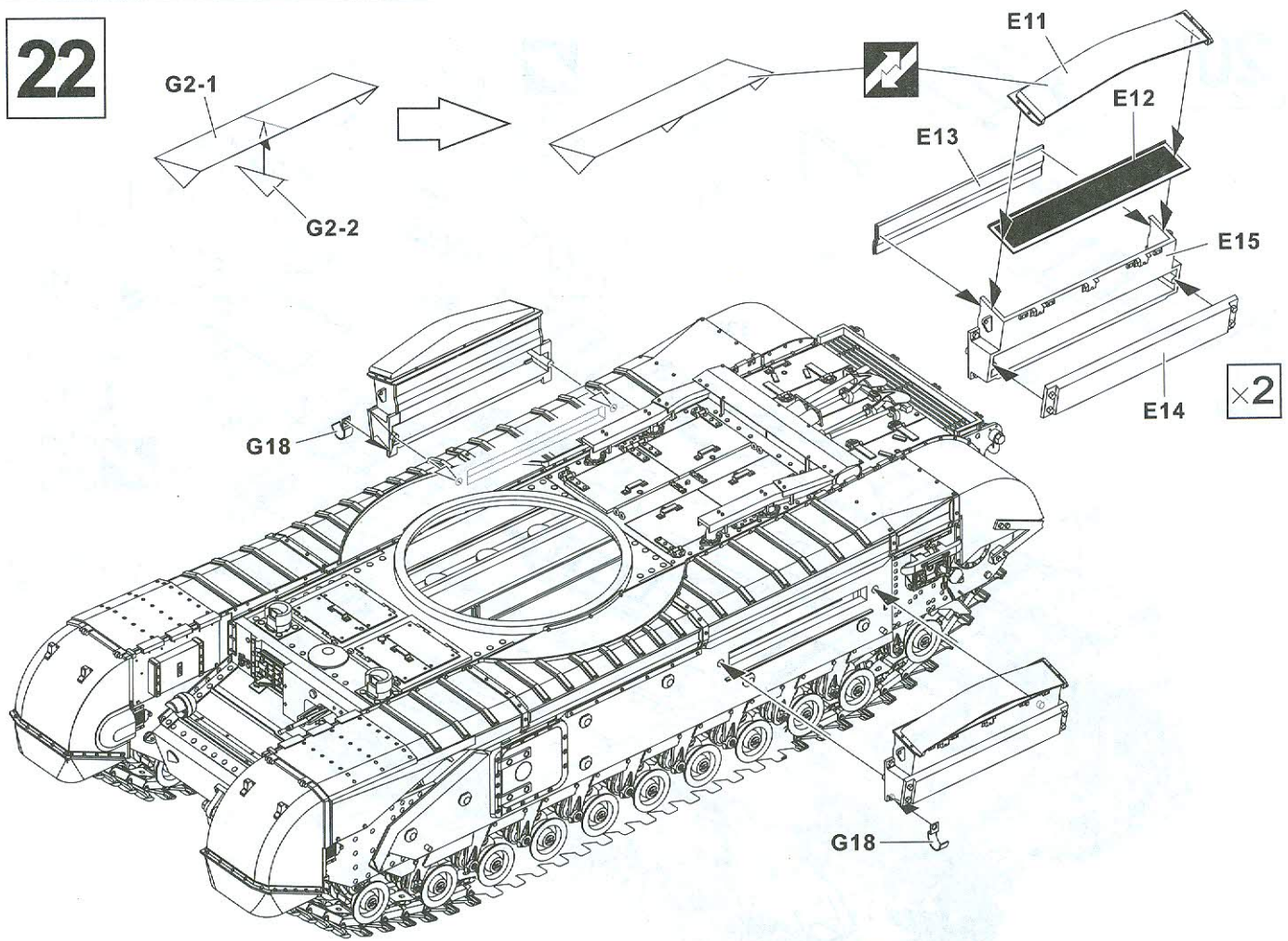

23

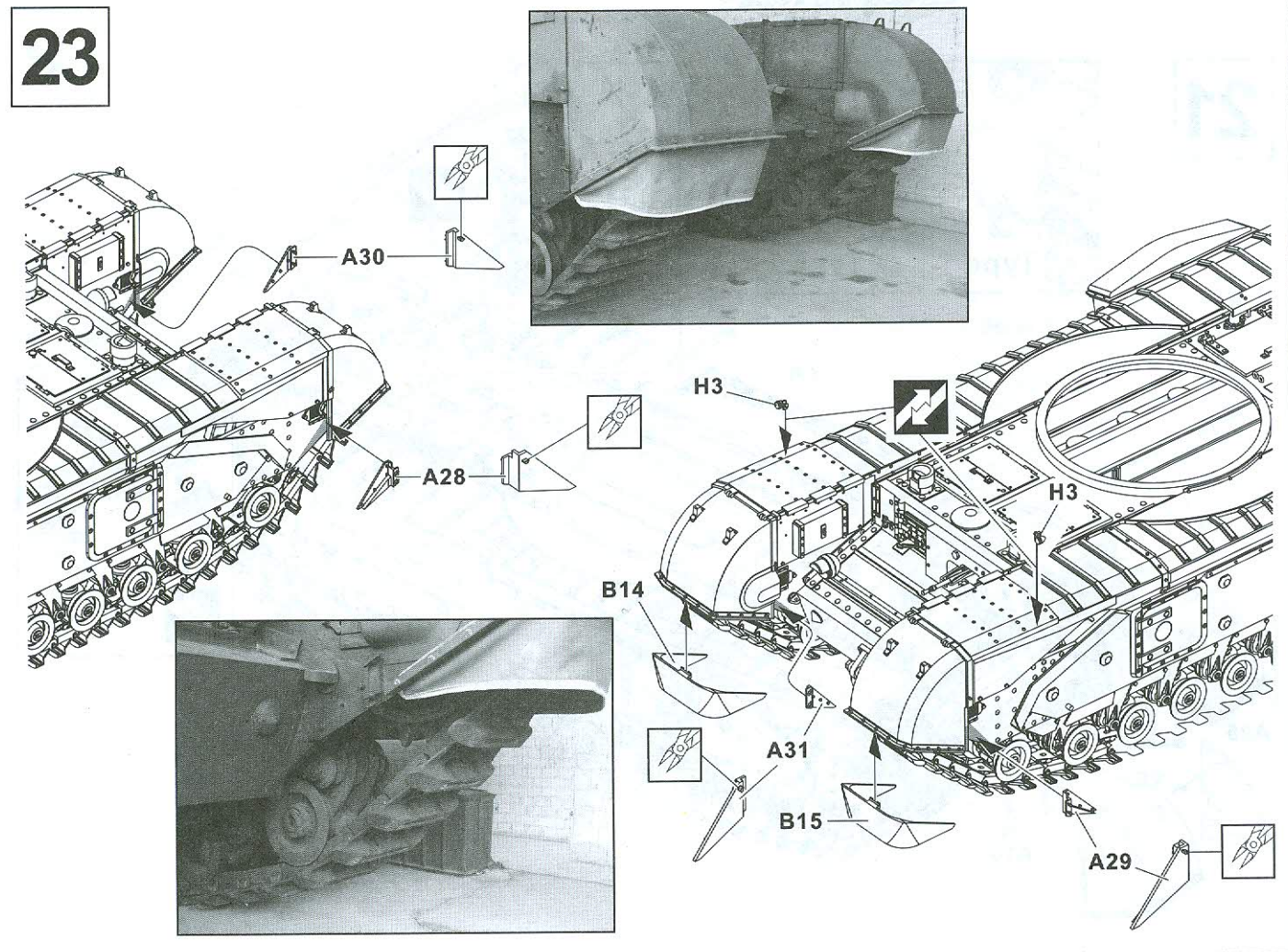

24

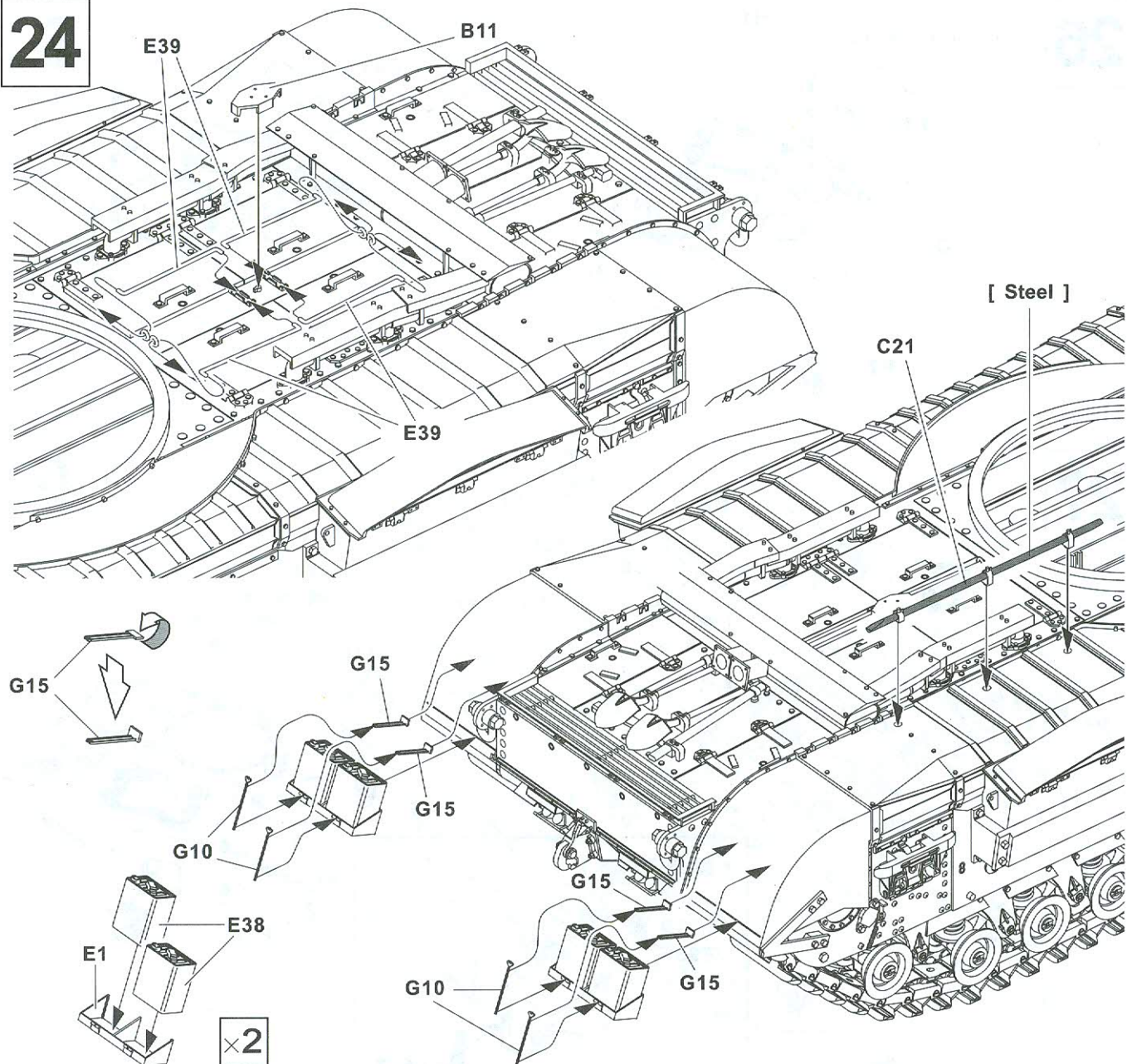

25

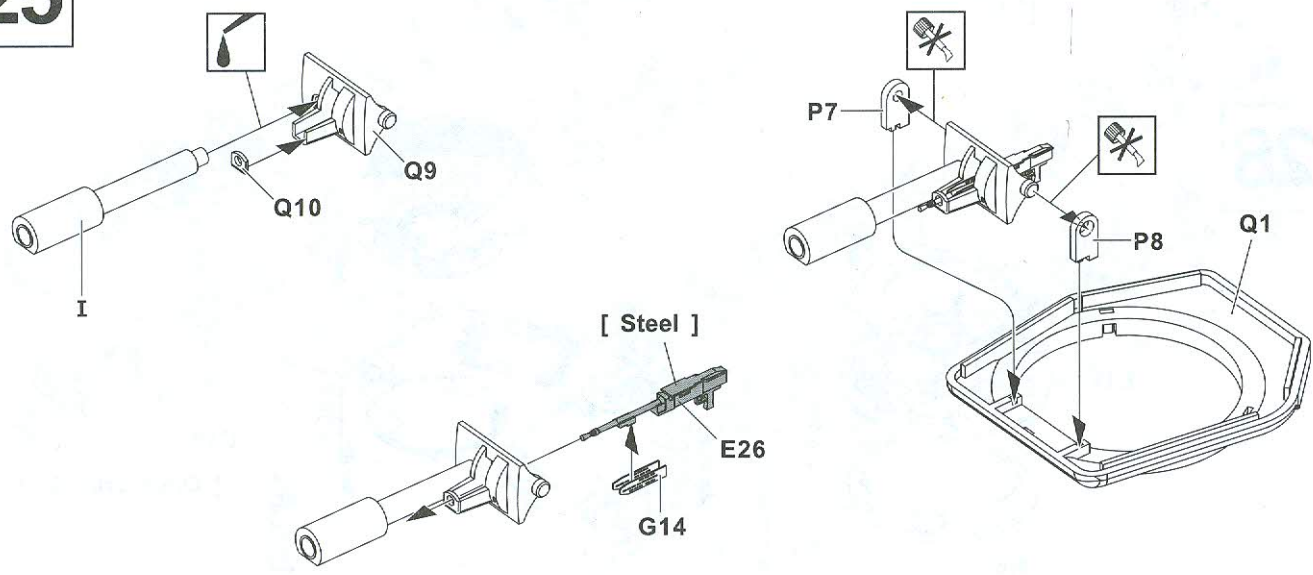

26

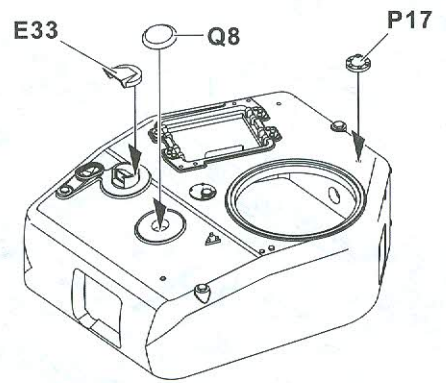
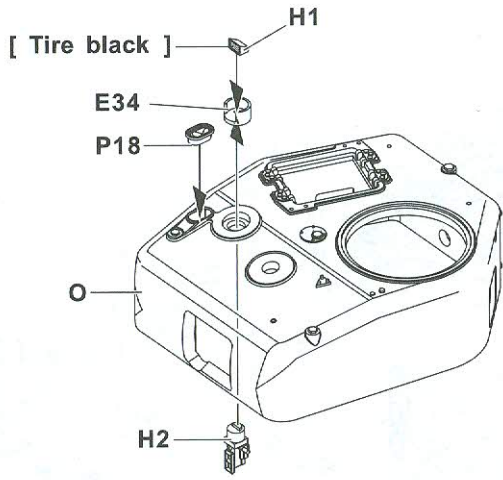

27

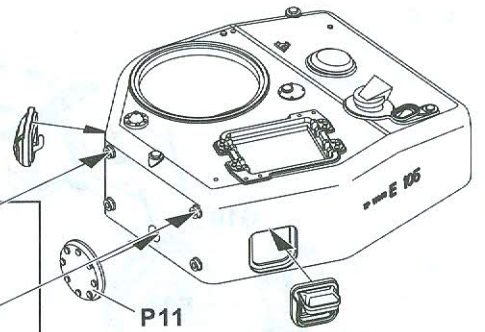
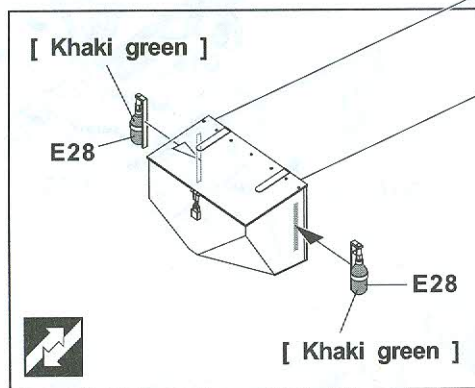
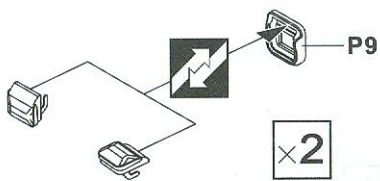
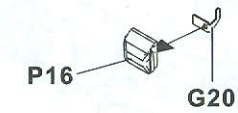
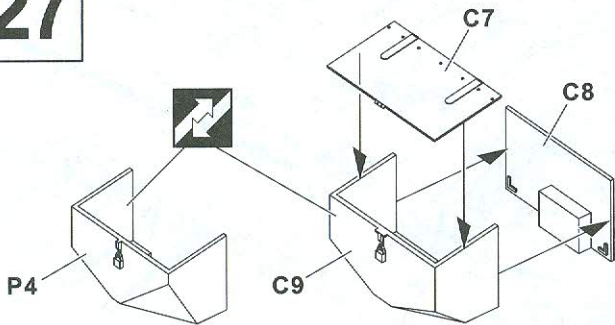

28

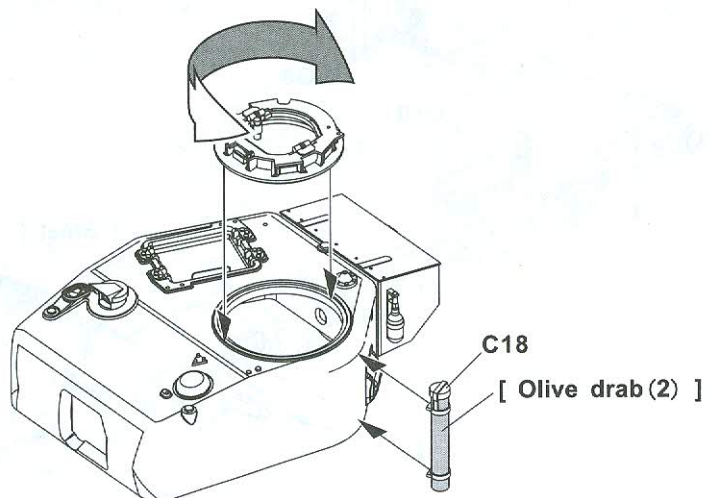
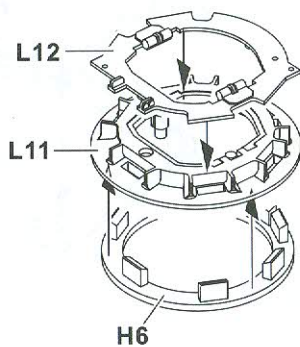

29

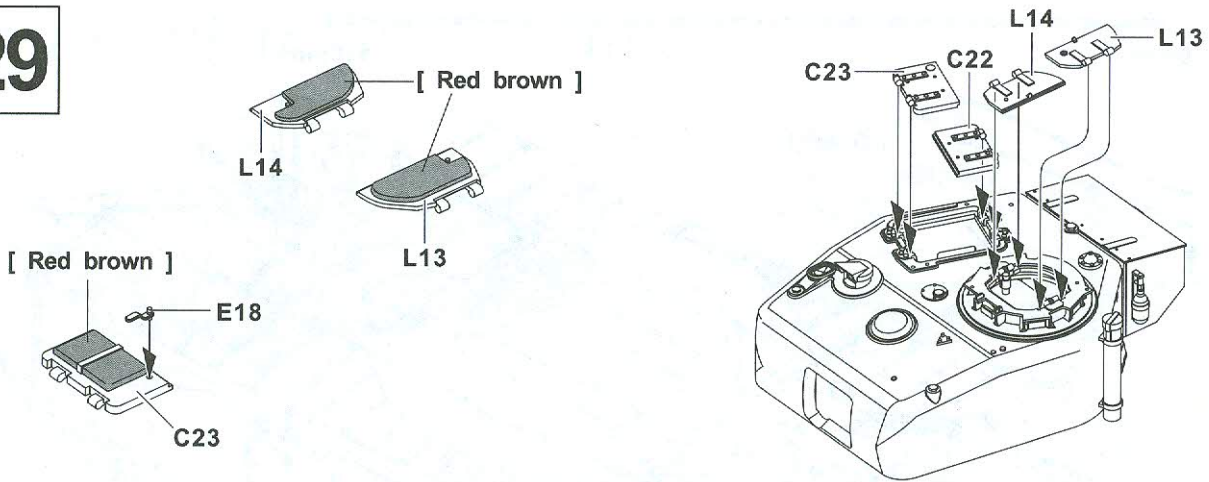

30

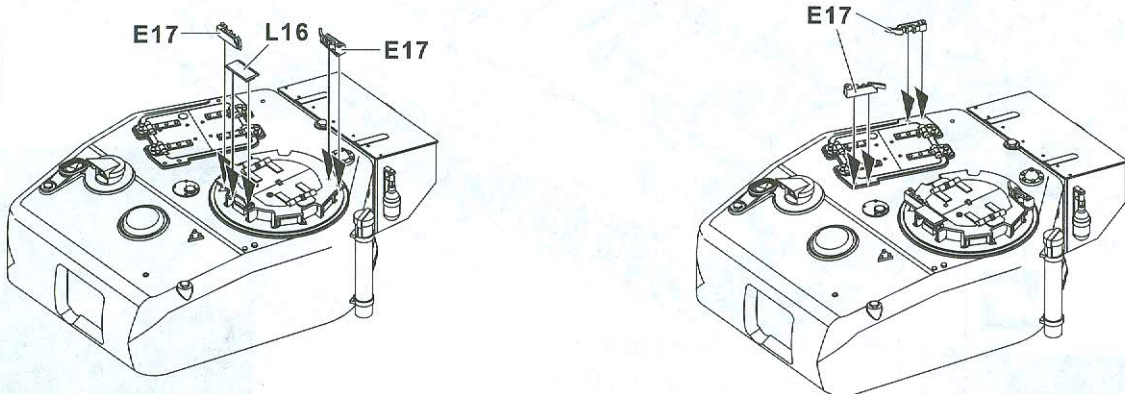

31

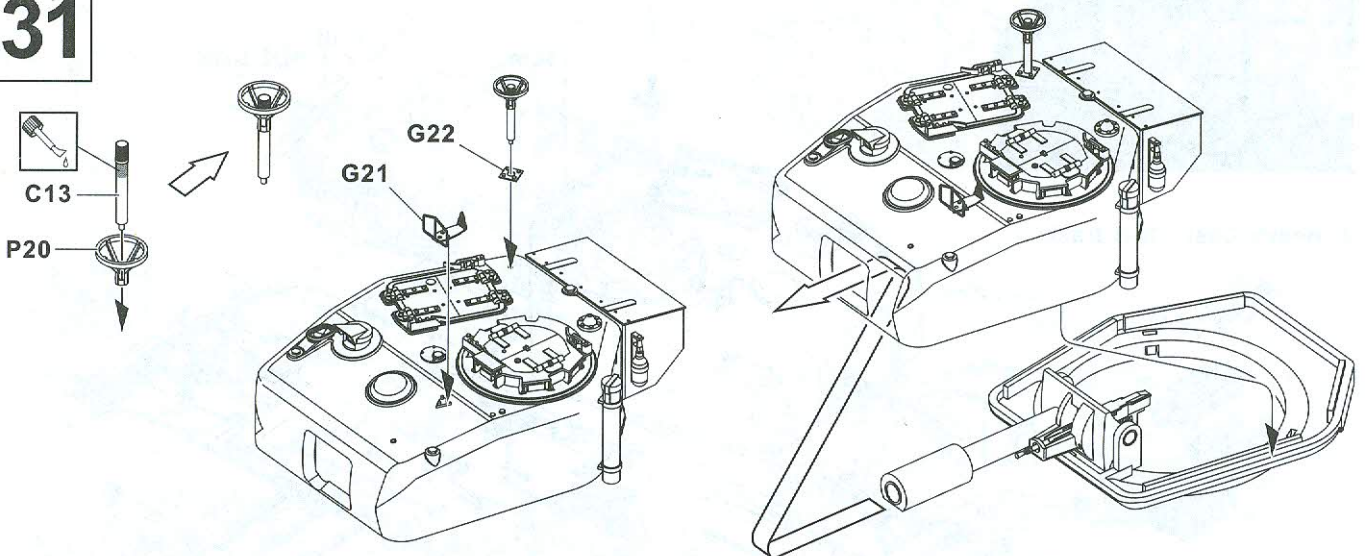

32

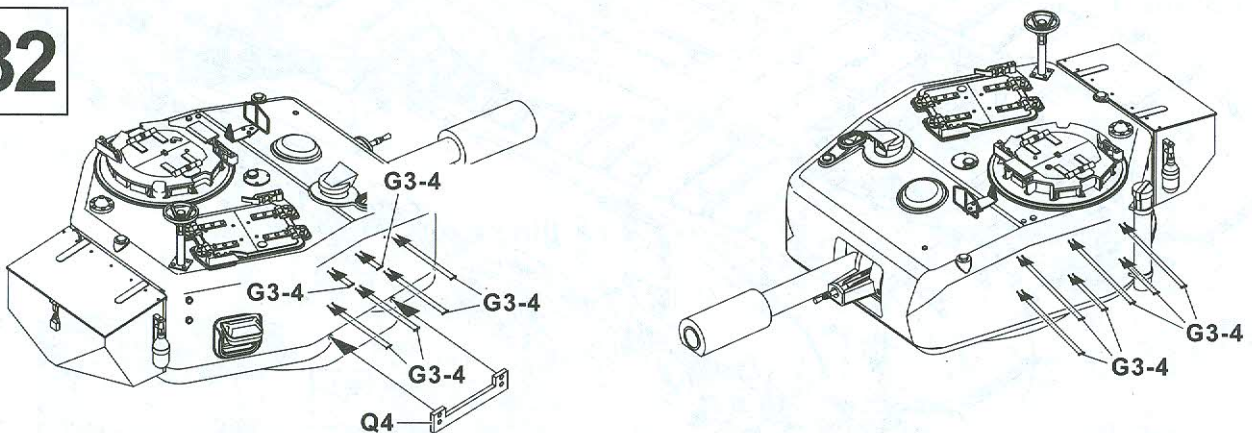

33

0mm

110mm

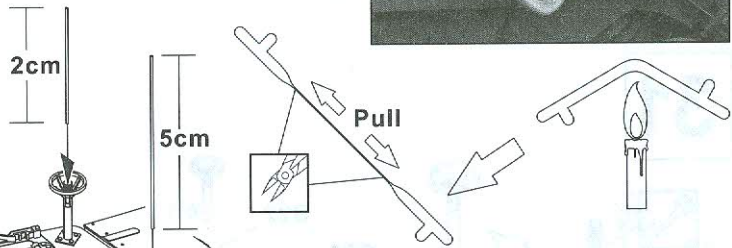
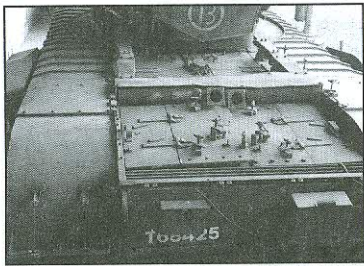
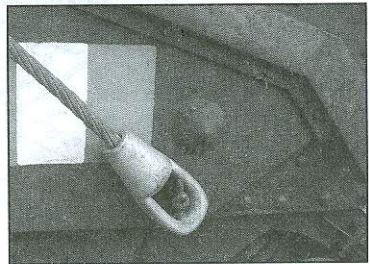
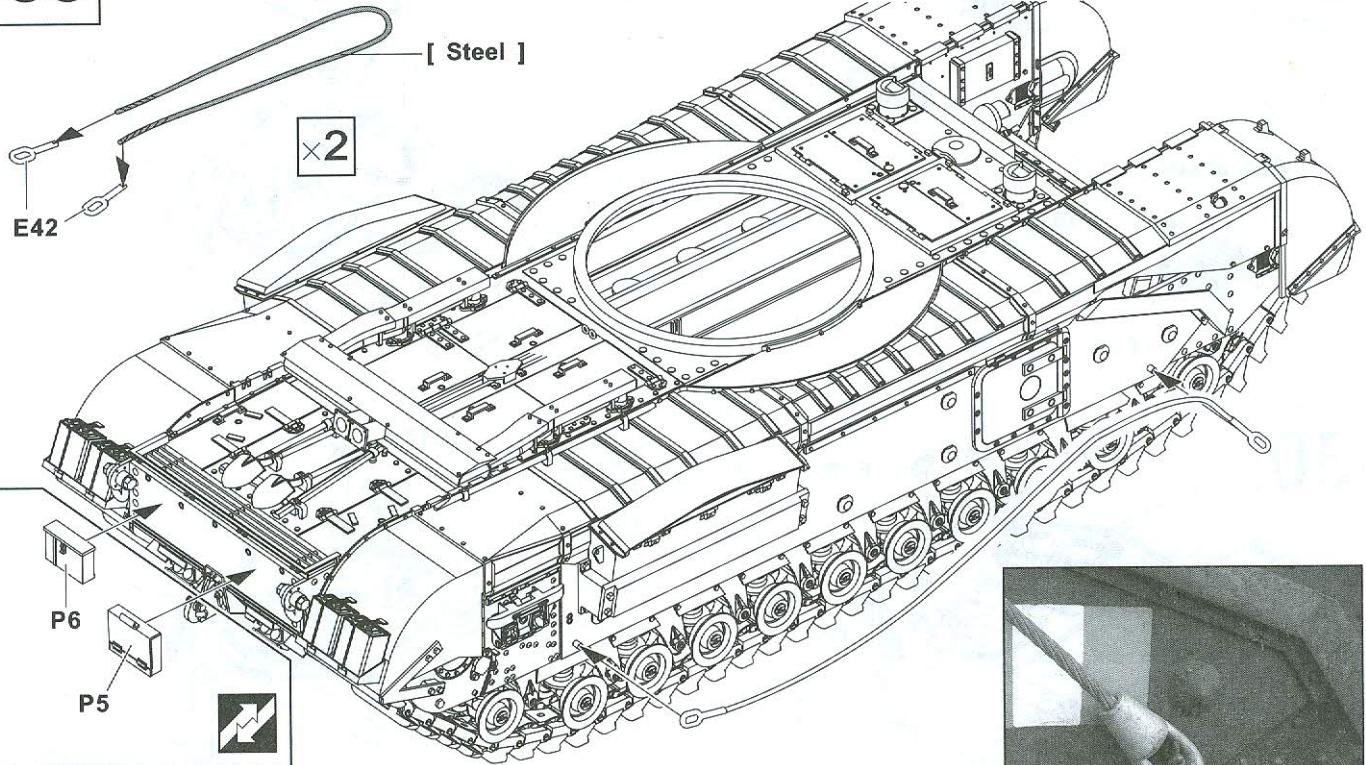

《 Heavy Cast Steel track 》

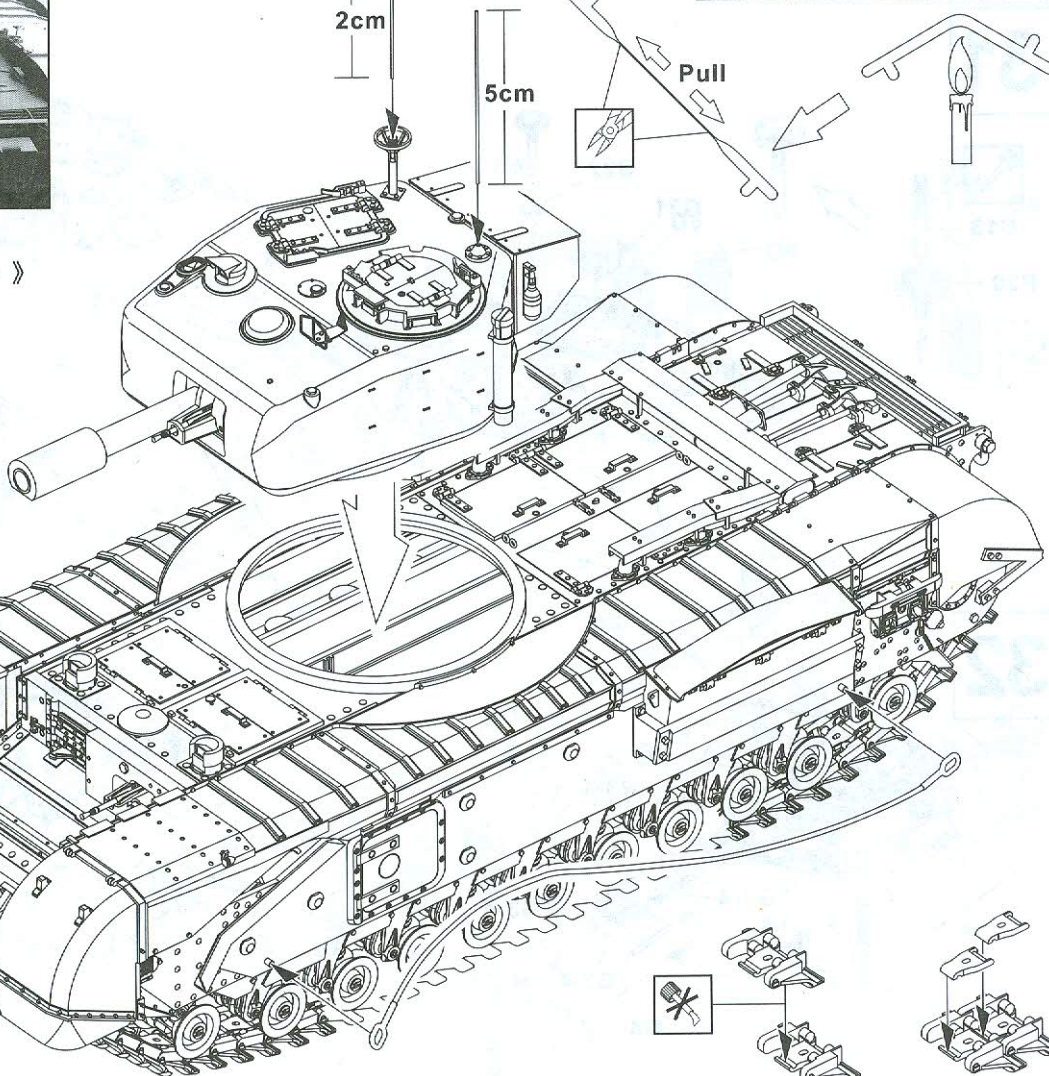
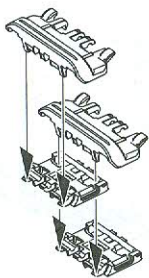

《 Light Cast Steel track 》

A 6th Guards Tank Brigade, Dutch, Oct. 1944
 第六近衛裝甲旅, 荷蘭境內, 1944年10月

 Body Color: Dark Green

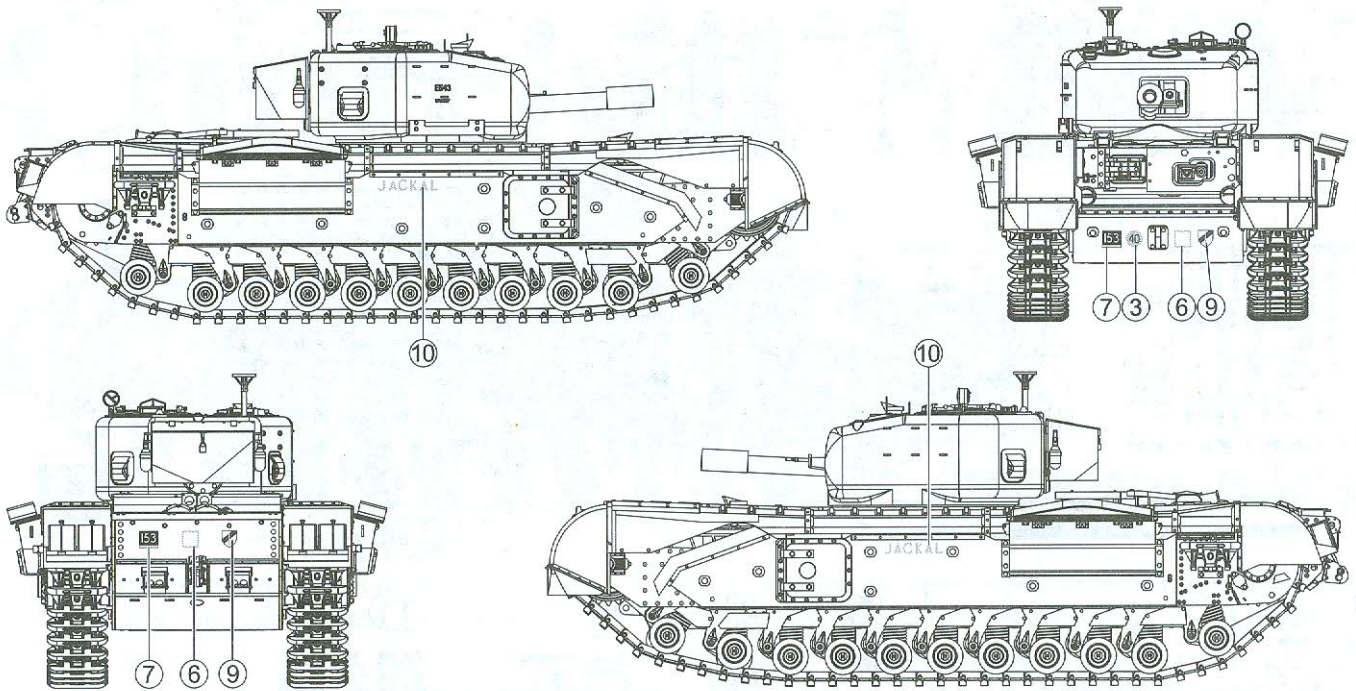

B Normandy, 1944
 諾曼地, 1944年

 Body Color: Dark Green

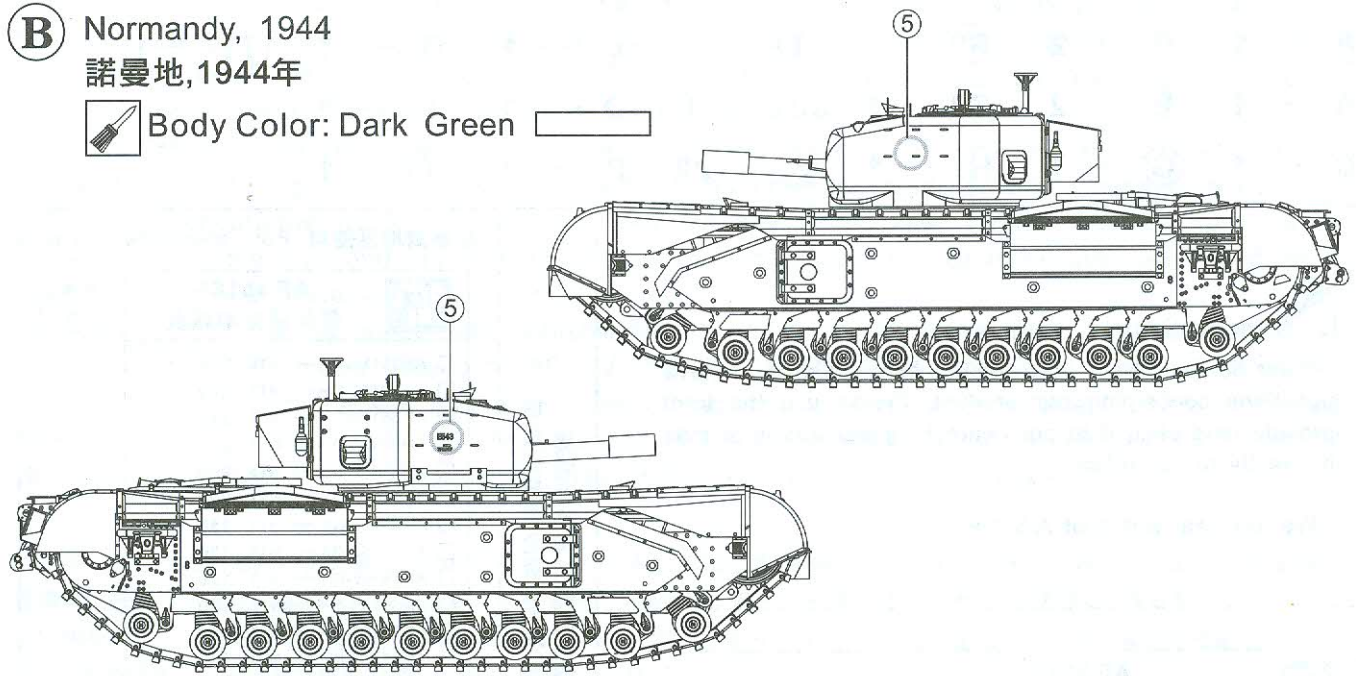

C  Body Color: Dark Green

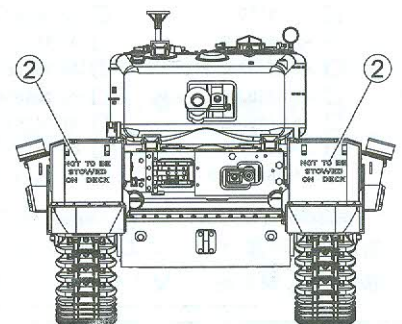

PARTS LIST 零件表

A AF 35153

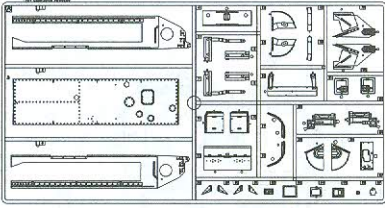

B AF 35153

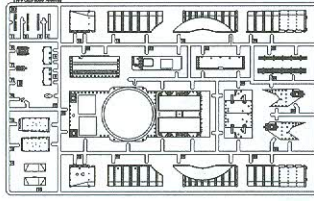

C AF 35153

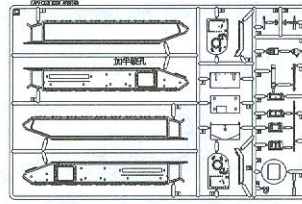

G AF 35167



D AF 35153

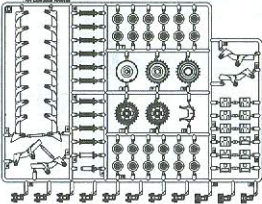

E AF 35153

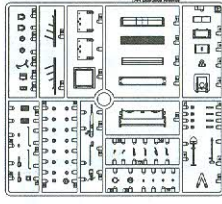

L AF 35167

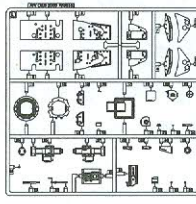

T2 AF 35183



G2 AF 35169



P AF 35154

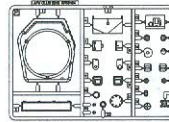

G3 AF 3552



T AF 35153



I AF 35155



H AF 35167



J AF 35155

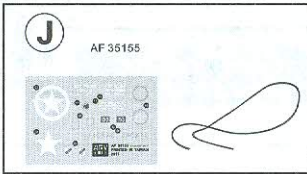

K AF 35153



O AF 35155



Q AF 35S52

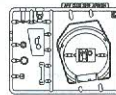

T1 AF 35156

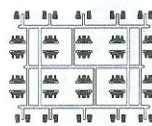

- A** — 1 **D** — 2 **G2** — 1 **I** — 1 **L** — 1 **Q** — 1 **T2** — 1
B — 1 **E** — 2 **G3** — 1 **J** — 1 **O** — 1 **T** — 1
C — 1 **G** — 1 **H** — 1 **K** — 22 **P** — 1 **T1** — 1



Instructions:

If for some reason, you are not fully satisfied or have questions concerning our product; Please use the form provide, and send it to our nearest representative or mail it directly to our office.

We will deal with that A.S.A.P.



AF 35155 Parts Replacement Form

- | | | |
|--------------------------------------|--------------------------------------|--------------------------------------|
| <input type="checkbox"/> AF 35153-A | <input type="checkbox"/> AF 35S52-G3 | <input type="checkbox"/> AF 35154-P |
| <input type="checkbox"/> AF 35153-B | <input type="checkbox"/> AF 35167-H | <input type="checkbox"/> AF 35S52-Q |
| <input type="checkbox"/> AF 35153-C | <input type="checkbox"/> AF 35155-I | <input type="checkbox"/> AF 35153-T |
| <input type="checkbox"/> AF 35153-D | <input type="checkbox"/> AF 35155-J | <input type="checkbox"/> AF 35156-T1 |
| <input type="checkbox"/> AF 35153-E | <input type="checkbox"/> AF 35153-K | <input type="checkbox"/> AF 35183-T2 |
| <input type="checkbox"/> AF 35167-G | <input type="checkbox"/> AF 35167-L | |
| <input type="checkbox"/> AF 35169-G2 | <input type="checkbox"/> AF 35154-O | |

Reason for replacement: Missing
 Broken

Signature: _____

限臺灣地區使用 For Taiwanese use only!



AF 35155 零件補充申請表

申請人
姓名 地址 電話

- | | |
|--------------------------------------|----------|
| <input type="checkbox"/> AF 35153-A | NT\$ 280 |
| <input type="checkbox"/> AF 35153-B | NT\$ 280 |
| <input type="checkbox"/> AF 35153-C | NT\$ 240 |
| <input type="checkbox"/> AF 35153-D | NT\$ 320 |
| <input type="checkbox"/> AF 35153-E | NT\$ 210 |
| <input type="checkbox"/> AF 35167-G | NT\$ 220 |
| <input type="checkbox"/> AF 35169-G2 | NT\$ 150 |
| <input type="checkbox"/> AF 35S52-G3 | NT\$ 150 |
| <input type="checkbox"/> AF 35167-H | NT\$ 120 |
| <input type="checkbox"/> AF 35155-I | NT\$ 180 |
| <input type="checkbox"/> AF 35155-J | NT\$ 160 |
| <input type="checkbox"/> AF 35153-K | NT\$ 100 |
| <input type="checkbox"/> AF 35167-L | NT\$ 280 |
| <input type="checkbox"/> AF 35154-O | NT\$ 150 |
| <input type="checkbox"/> AF 35154-P | NT\$ 200 |
| <input type="checkbox"/> AF 35S52-Q | NT\$ 150 |
| <input type="checkbox"/> AF 35153-T | NT\$ 280 |
| <input type="checkbox"/> AF 35156-T1 | NT\$ 80 |
| <input type="checkbox"/> AF 35183-T2 | NT\$ 100 |

+郵寄費 — NT\$ 80
 (請填) 總計 NT\$ _____

零件補充原因:(請於 打)

原包裝即 遺失或 毀損,
 製作途中 遺失或 毀損,
 其他原因 _____

總代理戰鷹企業有限公司收本公司將儘速為您處理。
 請將本表與該部品相同金額之郵政匯票一同寄至。