

MIRAGE F1 CR



80355

F Le programme du F-1 fut lancé en 1967 afin de réaliser un successeur à la lignée Mirage III. Le F-1 a été conçu pour être un monoplace bisonique de supériorité aérienne. Le dernier développement du Mirage F-1 est la version de reconnaissance F-1 CR ravitaillable en vol qui fit son premier vol le 10 Novembre 1982.

Longueur : 15,10 m
Envergure : 8,45 m
Hauteur : 4,49 m
Propulseur : Atar 9 K 50
Poids maximum : 11500 kg
Vitesse maximum : Mach 2,1

I Il programma dell'F-1 è stato lanciato nel 1967, nel quadro della successione linea Mirage III. L'F-1 è stato progettato come monoposto bisonico di superiorità aerea. L'ultimo sviluppo del Mirage F-1 è costituito dalla versione da ricognizione aerea F-1 CR, rifornibile in volo, che ha effettuato il suo primo volo il 10 Novembre 1982.

Lunghezza : 15,10 m
Apertura alare : 8,45 m
Altezza : 4,49 m
Motore : Atar 9 K 50
Peso massimo : 11500 kg
Velocità massima : Mach 2,1

GB The F-1 programme was launched in 1967 for the purpose of designing and constructing a successor to the Mirage III line. The F-1 C was designed as a bisonic single-seater for air superiority. The latest development of the Mirage F-1 is the F-1 CR reconnaissance version which can be refuelled in flight. It made its maiden flight on the 10th November 1982.

Length : 15.10 m
Wingspan : 8.45 m
Height : 4.49 m
Engine : Atar 9 K 50
Maximum weight : 11500 kg
Top speed : Mach 2.1

NL Het programma van de F-1 werd in 1967 gelanceerd, ten einde een opvolger in het Mirage III nakomelingschap te verwezenlijken. De F-1 C werd ontworpen om een bisonisch eenpersoonsvliegtuig van luchtoverwicht te zijn. De laatste ontwikkeling van de Mirage F-1 is de verkenningversie F-1 CR gedurende de vlucht met benzine te laden. Op 10 november 1982 verwezenlijkte hij zijn eerste vlucht.

Lengte : 15,10 m
Spanwijdte : 8,45 m
Hoogte : 4,49 m
Motor : Atar 9 K 50
Max. gewicht : 11500 kg
Max. snelheid : Mach 2,1

D Das Programm der F-1 wurde 1967 aufgenommen, um einen Nachfolger für die Serie Mirage III zu schaffen. Die F-1 wurde entwickelt mit doppelter Schallgeschwindigkeit für die Wahrung von Lufthoheitsaufgaben. Die letzte Entwicklung des Mirage F-1 ist die im Flug auftankbare Aufklärungsvariante F-1 CR, die erstmals am 10. November 1982 flog.

Länge : 15,10 m
Flügelweite : 8,45 m
Höhe : 4,49 m
Antrieb : Atar 9 K 50
Max. Gewicht : 11500 kg
Max. Geschwindigkeit : Mach 2,1

S F-1 programmet lanserades år 1967 med avsikten att framställa en efterföljare till plantypen Mirage III. F-1 CR planerades som ett ensigtsigt tvåljudsplan. Den senaste Mirage F-1 modellen är flyspaningversionen F-1 CR som kan tankas i luften och som flög för första gången den 10 november 1982.

Längd: 15,10 m
Vingbredd: 8,45 m
Höjd: 4,49 m
Motor: Atar 9 K 50
Maximivikt: 11500 kg
Maximihastighet: 2,1 Mach









E El programa del F-1 fue lanzado en 1967 con el propósito de dar un sucesor a la estirpe de los Mirage III. El F-1 fue diseñado para ser un monoplaza bisónico de superioridad aérea. el último desarrollo del Mirage F-1 es la versión de reconocimiento F-1 CR avituallable en vuelo cuyo primer vuelo tuvo lugar el 10 Noviembre 1982.

Longitud : 15,10 m
Envergura : 8,45 m
Altura : 4,49 m
Motor : Atar 9 K 50
Peso máx. : 11500 kg
Velocidad máx. : 2,1 Mach

FI F-1 koneen suunnittelu alkoi vuonna 1967 kun haluttiin Mirage III koneelle seuraajaa. F-1 CR rakennettiin kaksiaäniseksi ja yksipaikkaiseksi lentokoneeksi. Mirage F-1 koneen viimeinen versio on lentotähystäjä F-1 CR jolle voi antaa polttoainetta lennon aikana ja joka suoritti ensimmäisen lentonsa 10 marraskuuta 1982.

Pituus: 15,10 m
Siipien väli: 8,45 m
Korkeus: 4,49 m
Moottori: Atar 9 K 50
Maksimipaino: 11500 kg
Maksiminopeus: 2,1 Mach

COULEURS RECOMMANDEES :

 5 Gris foncé Amiral brillant Gloss Dark Admiralty grey Glänzend-Dunklgrau	 11 Argent Silver Silber	 19 Rouge vif brillant Gloss bright red Glänzend-Hellrot	 27 Gris mer mat Matt sea grey Matt-Seegrau	 33 Noir mat Matt black Matt schwarz	 34 Blanc mat Matt white Mattweiss
 56 Aluminium Aluminium Aluminium	 64 Gris clair mat Matt light grey Matt-Hellgrau	 85 Noir de charbon satiné Satin coal black Seidenmatt-Kohlenschwarz	 102 Vert armée mat Matt army green Matt Armeegrün	$M1 = \frac{1}{2} \begin{matrix} \text{11} \\ \text{11} \end{matrix} + \frac{1}{2} \begin{matrix} \text{64} \\ \text{64} \end{matrix}$	

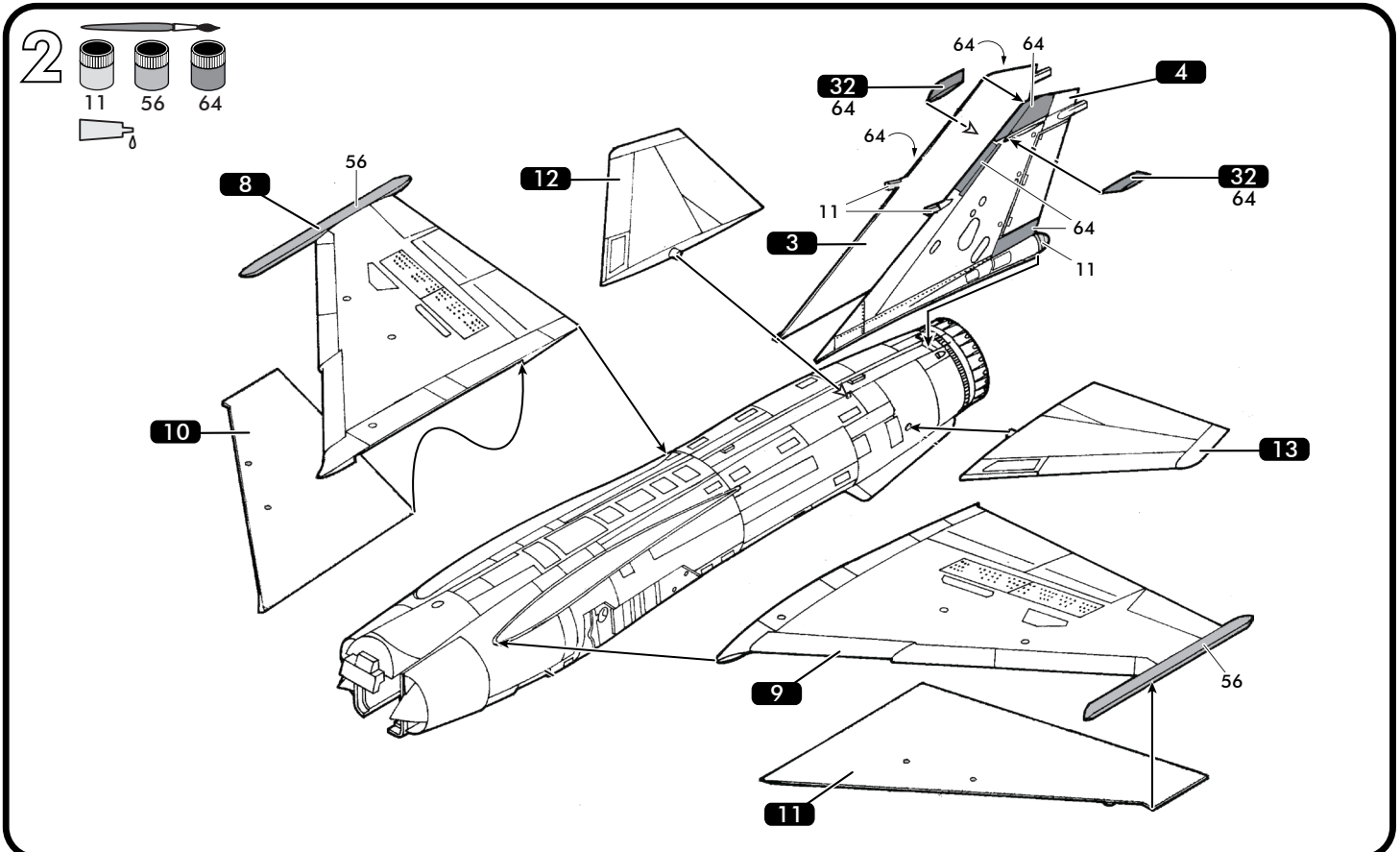
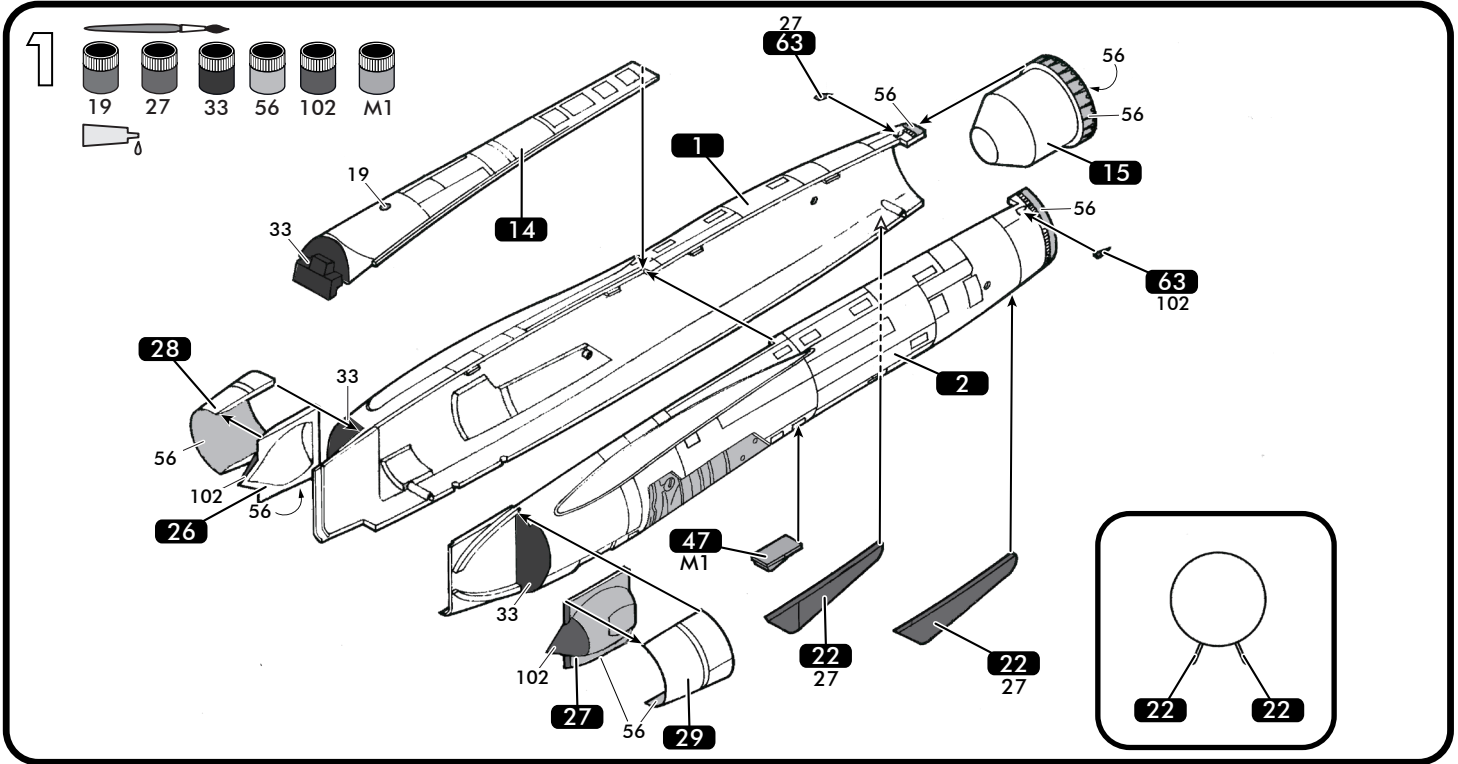

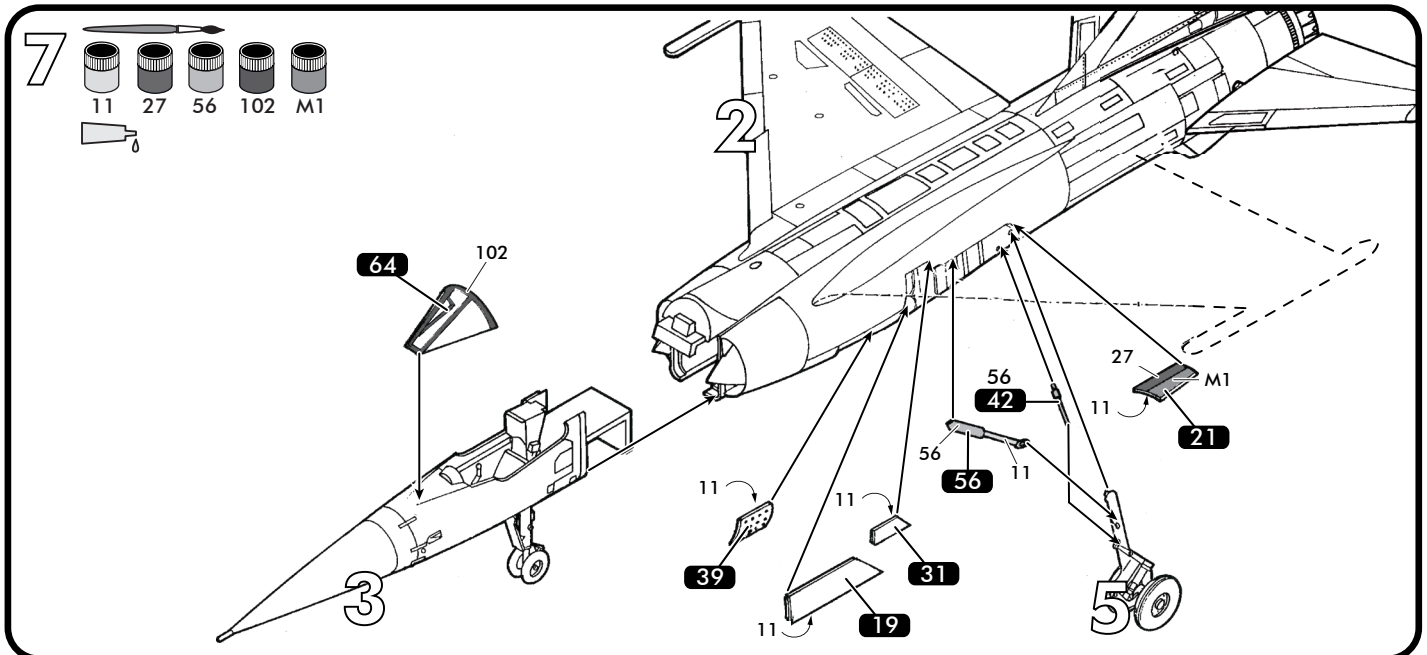
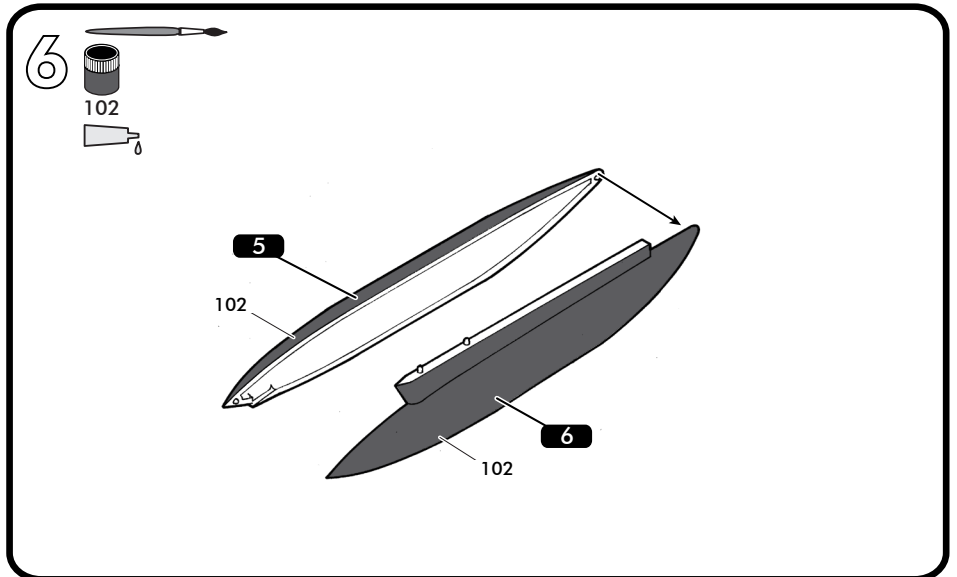
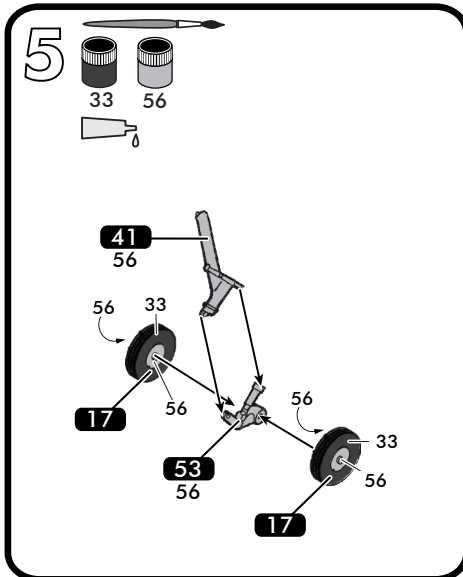
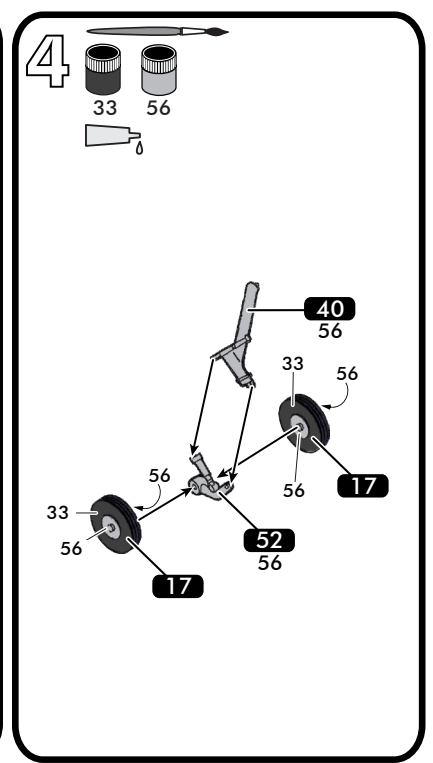
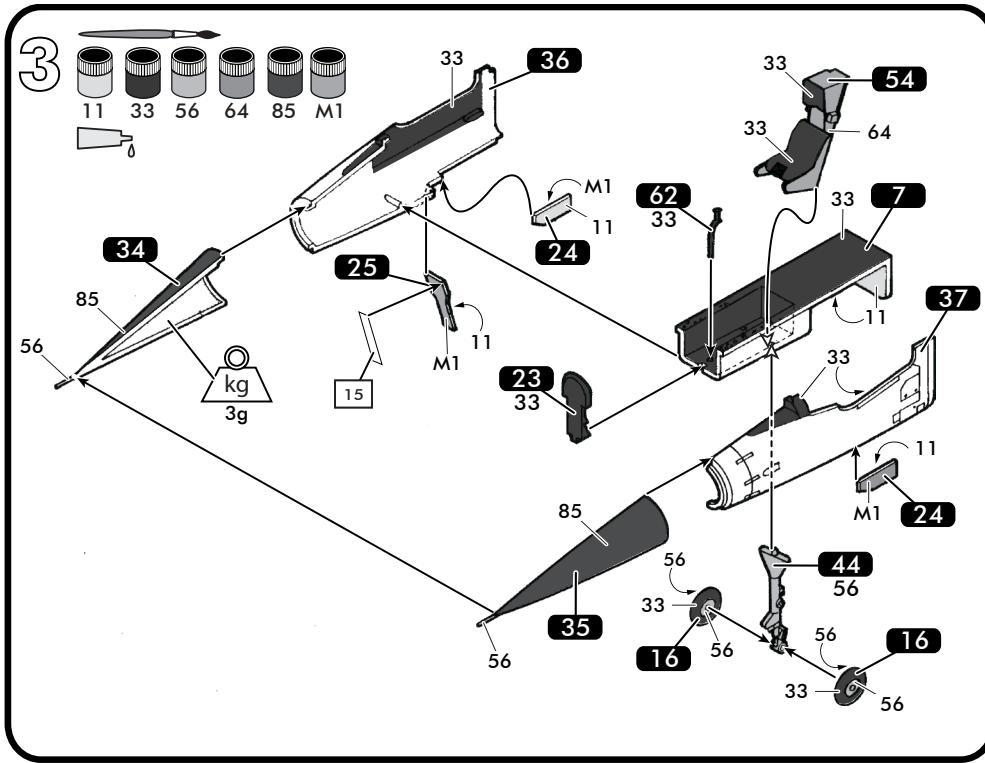

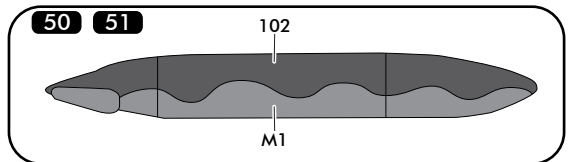
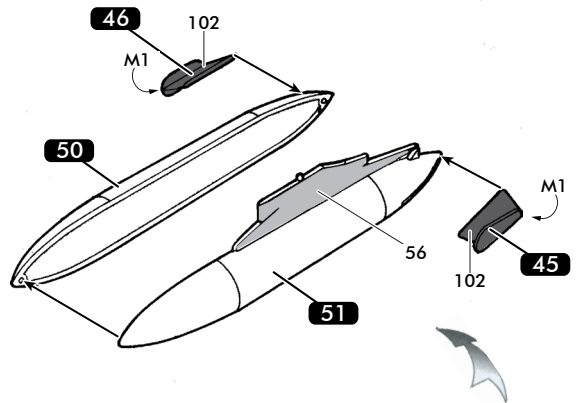
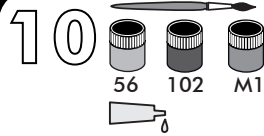
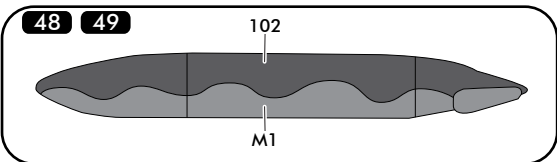
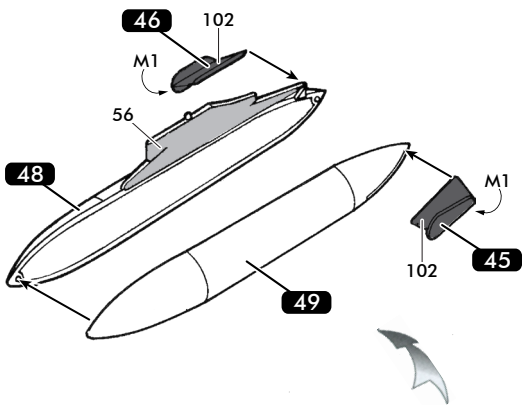
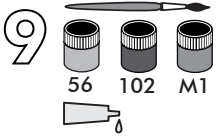
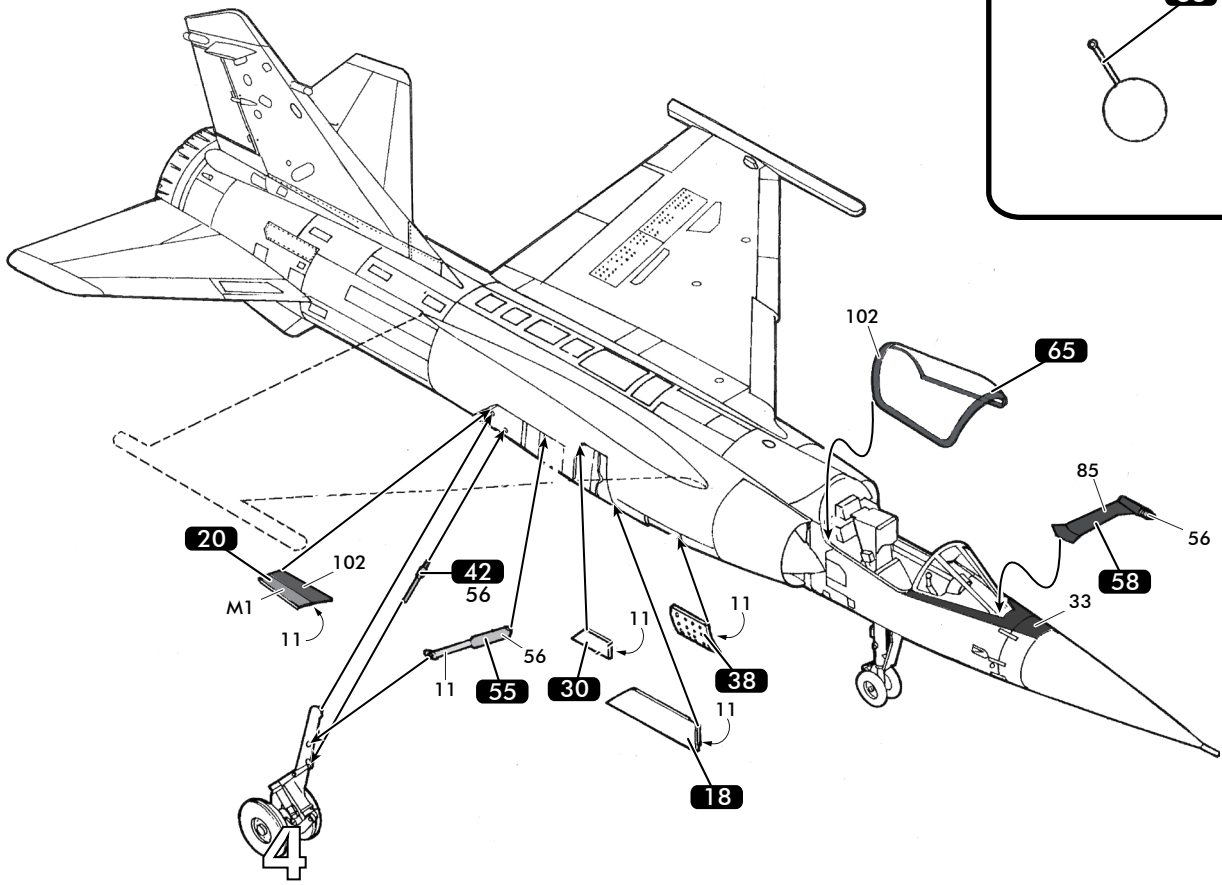
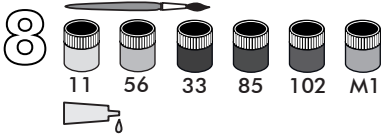

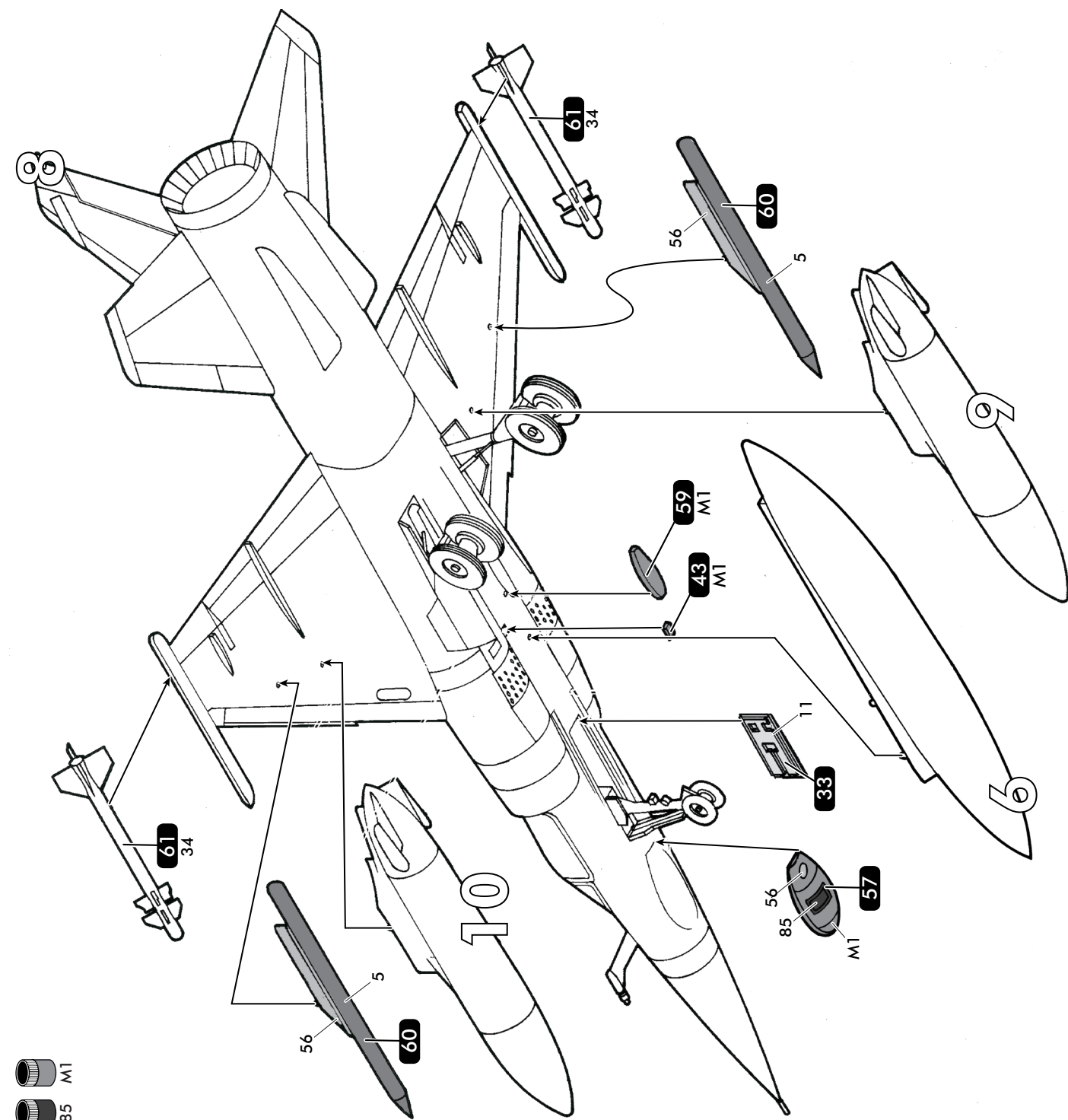

- 56 M1
- 85 M1
- 56 M1
- 34 M1
- 11 M1
- 5 M1
- 6

12

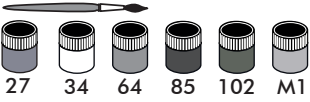

FRANCE : MIRAGE F-1 CR - E.R. 2/33 SAVOIE - STRASBOURG - 1984

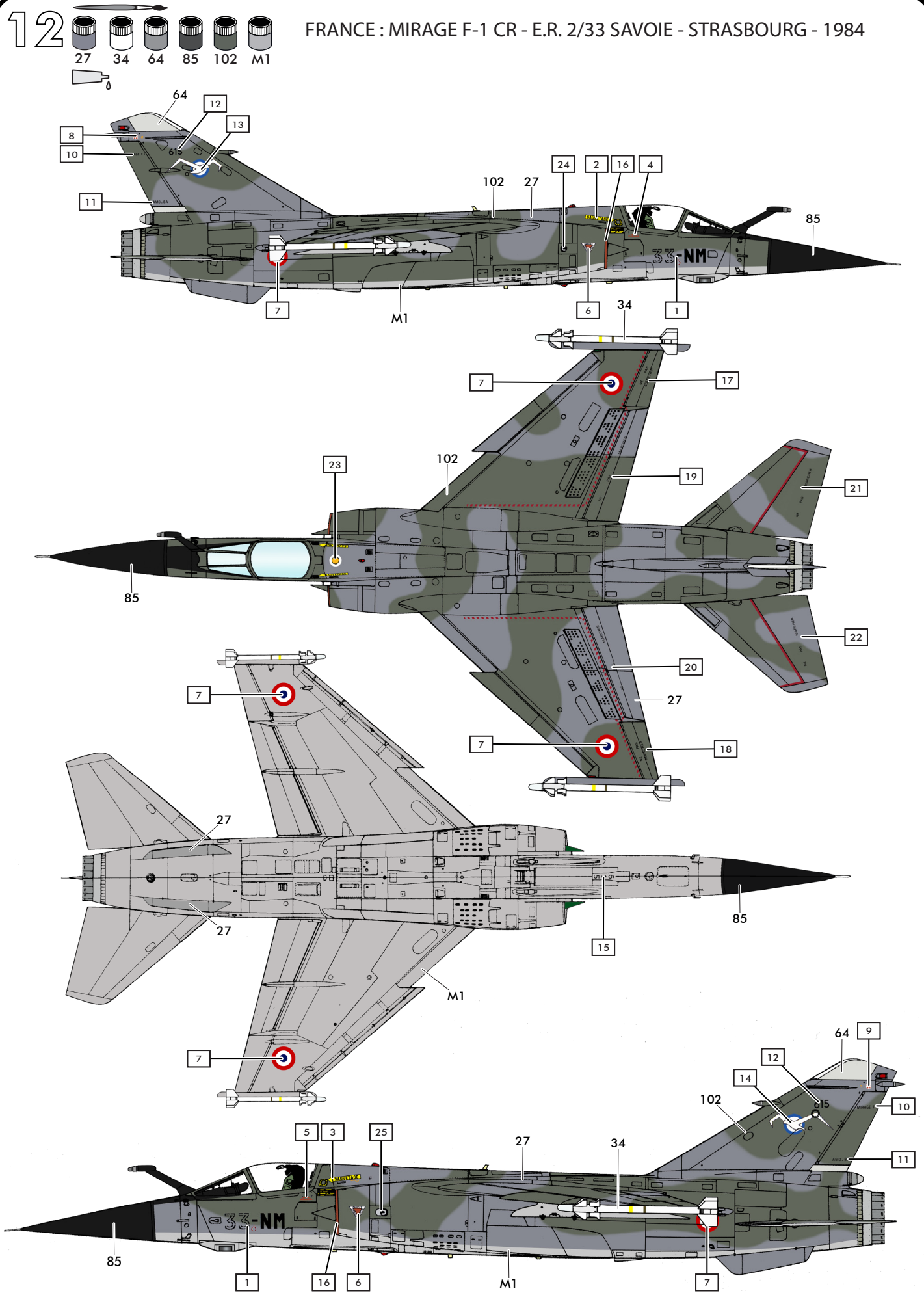

SERVICE CONSOMMATEURS 



+33 (0)2 33 67 72 72



+33 (0)2 33 36 57 07

www.heller.fr

HELLER JOUSTRA SA

Chemin de la Porte

61160 - TRUN

FRANCE



Fabriqué en France