

**1/24  
SCALE**

CONTAINS BASIC MARKINGS AND STENCIL MASKS FOR AIRFIX

# SPITFIRE Mk IXc

## 1/24 SCALE HIGH DEFINITION AIRBRUSH MASKS



**MASK, AIRBRUSH  
AND READY  
LIFE UNCOMPLICATED !**

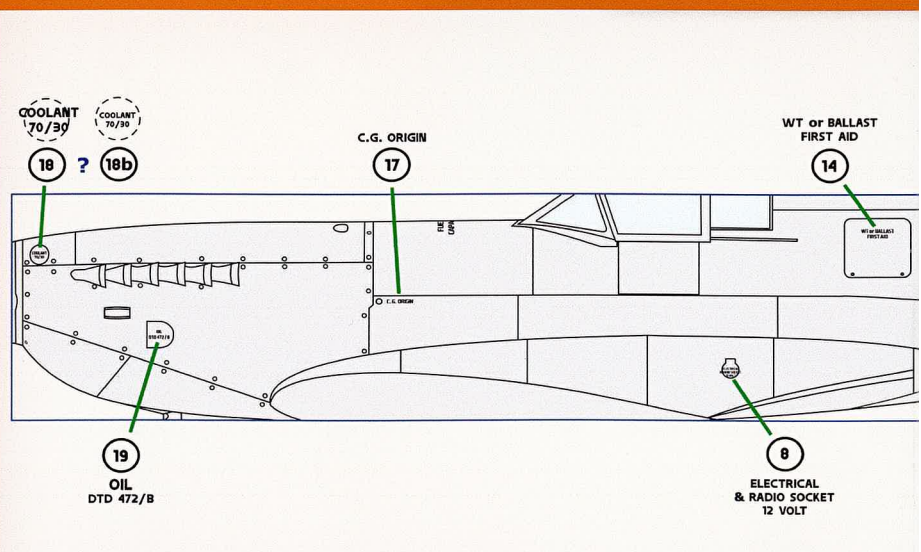

**DETAILED INSTRUCTIONS INSIDE**



**MADE IN BELGIUM | WWW.1MANARMY.BE | REF. 24DETO16**



**WALK LINES:**

Check your references as to length. Use the IMA strips only as a guideline. Trim and position on model and then mask off around. Remove IMA strips and airbrush. Try the spares 'x' first on a piece of scrap.

# TOP SIDE VIEW

**WALK LINES:**

Check your references as to length. Use the IMA strips only as a guideline. Trim and position on model and then mask off around. Remove IMA strips and airbrush. Try the spares 'x' first on a piece of scrap.

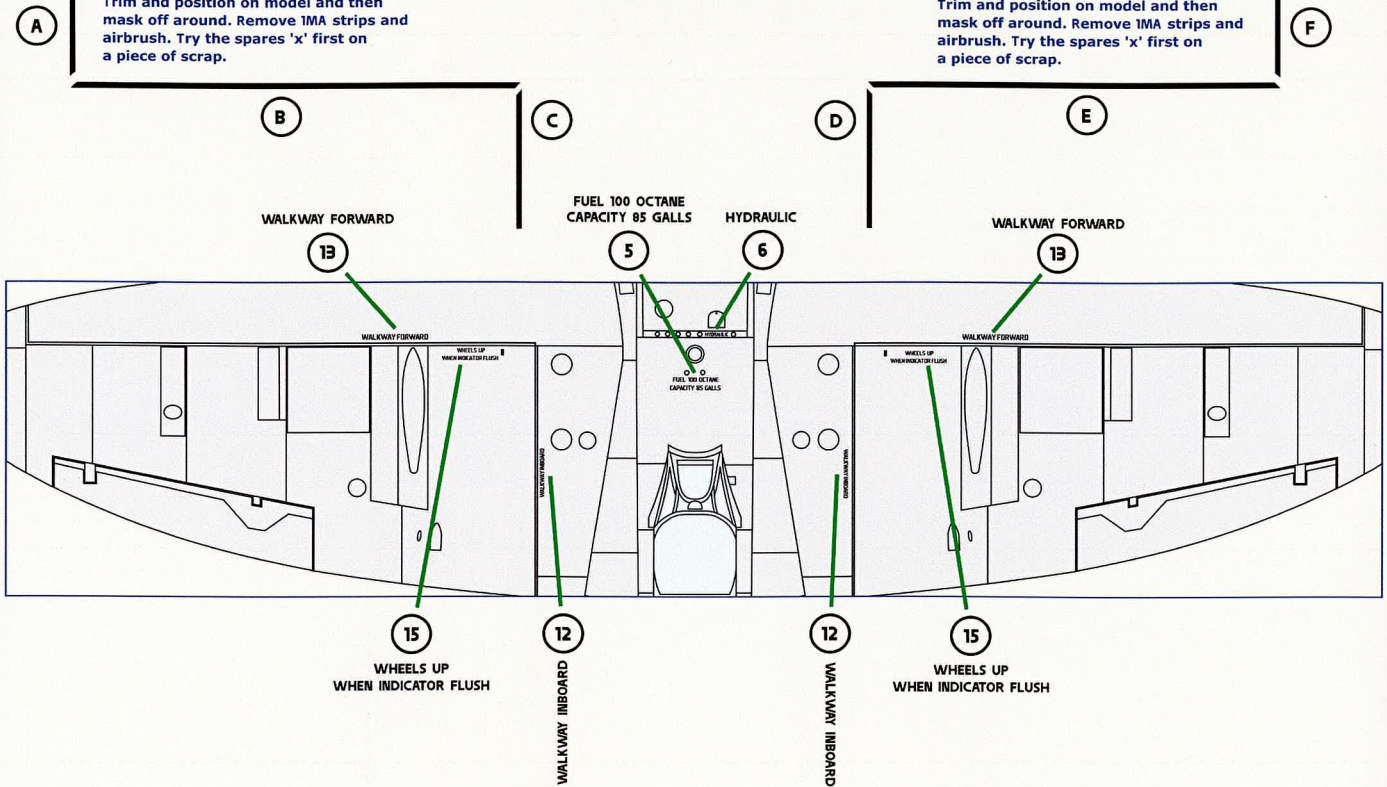

# LEFT SIDE VIEW

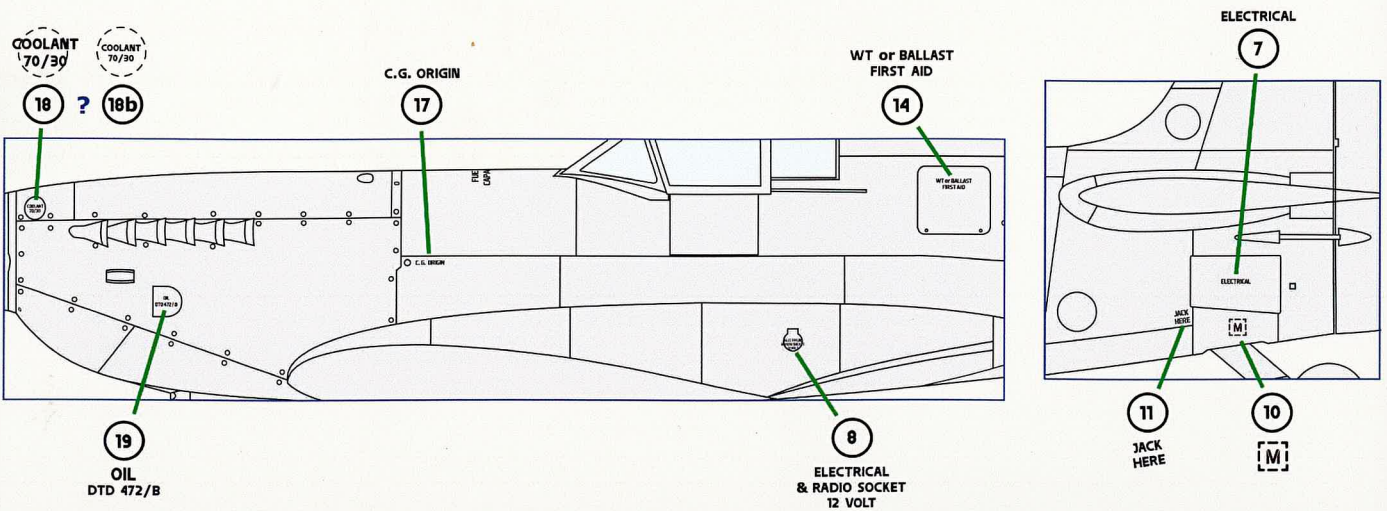

# UNDERSIDE VIEW

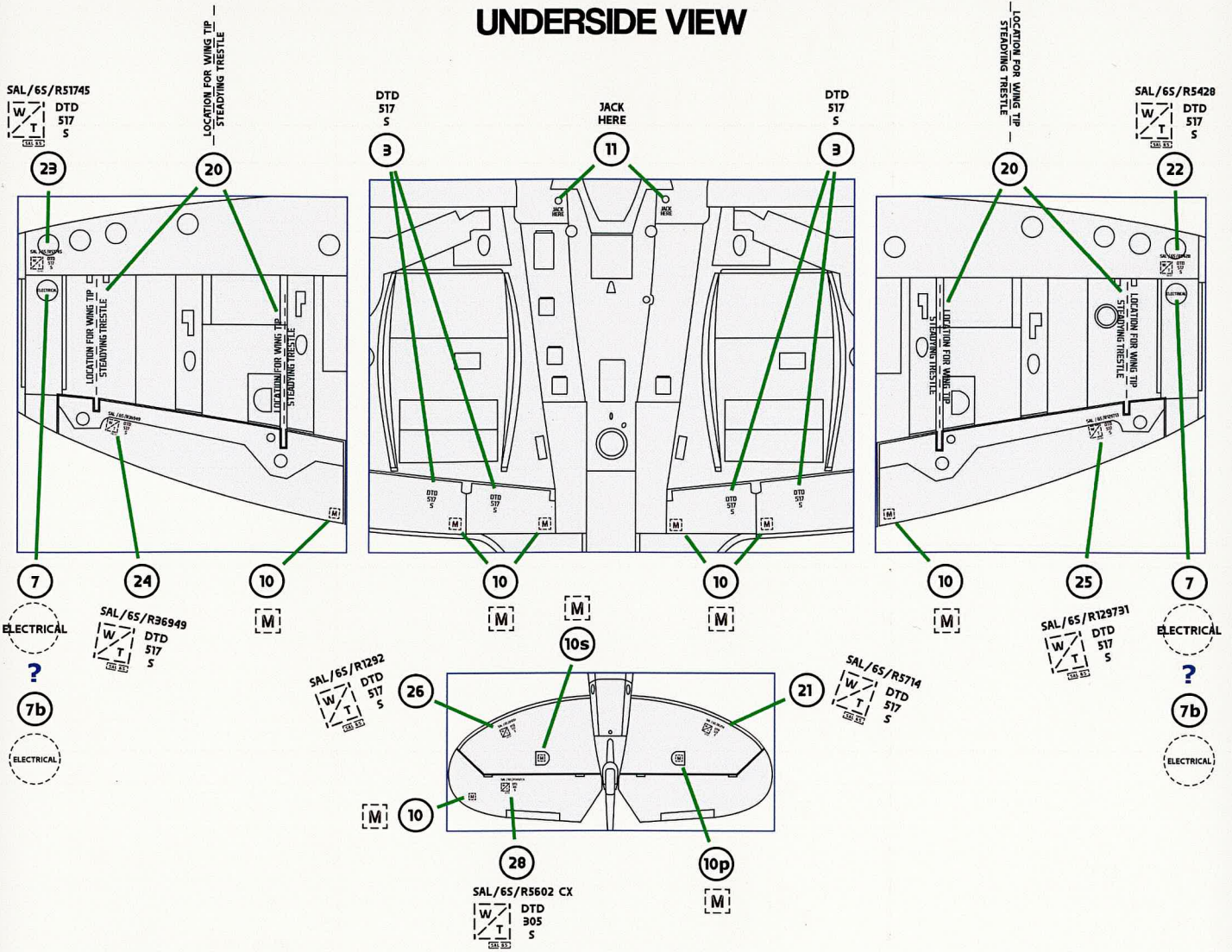

# RIGHT SIDE VIEW

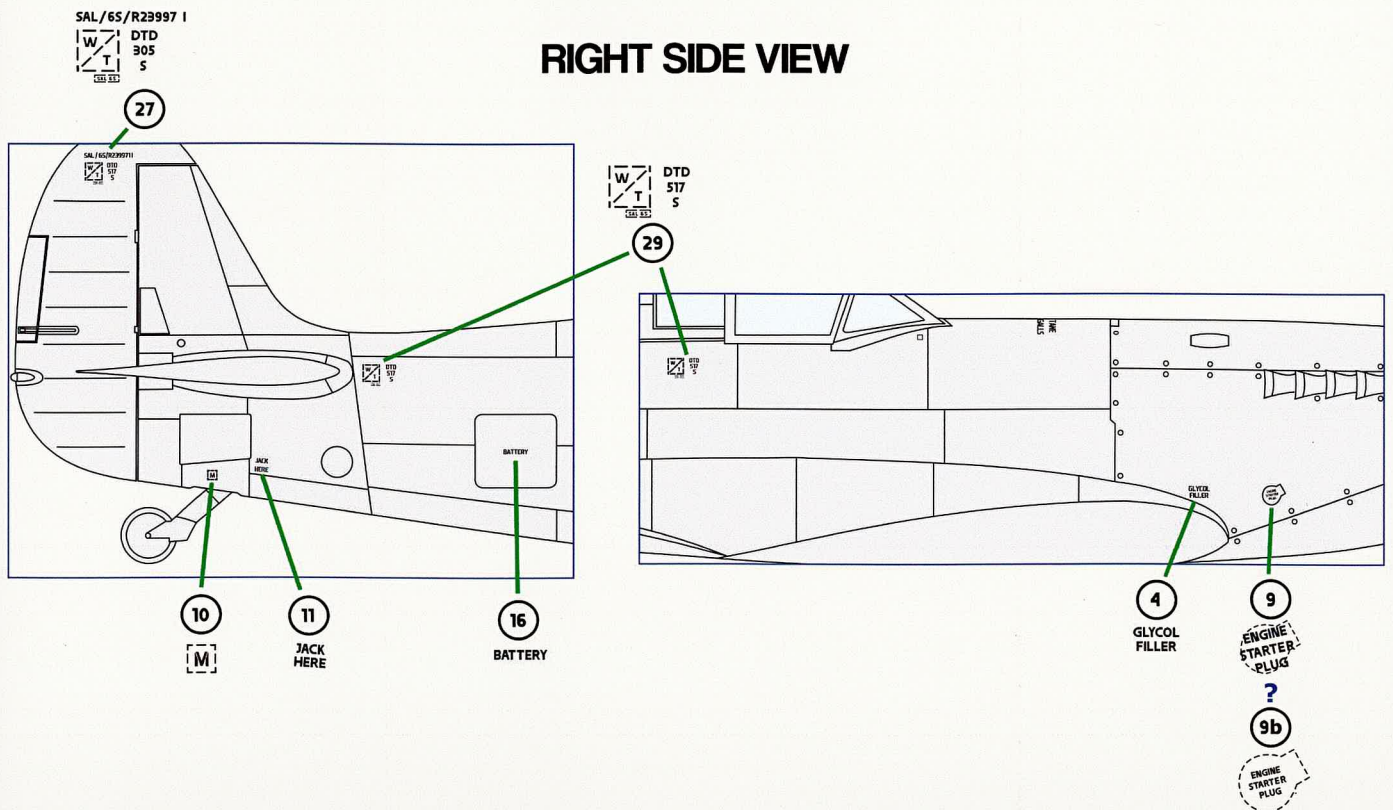



# ADDITIONAL MASKS

Spitfire Mk IXc No. 402 Squadron "City of Winnipeg"  
W/Cdr. James Edgar "Johnnie" Johnson RAF England 1943

EN398

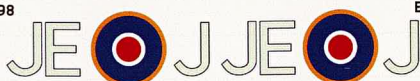

EN398

Check references on position and height of markings



Both sides of the fuselage. Check your references as to colour. First start with contour and paint white Weed leaf, apply transfer and insert circle. Mask off.

## Topside wings



1a Blue  
1b Red  
For 1a use 1ab contour

## Underside wings



10a Blue  
10b White  
10c Red  
For 10a use 10abc contour  
Different ways in possible order of masks and what colour first.

## Fuselage both sides



2a Yellow  
2b Blue  
2c White  
2d Red  
For 2a use 2abcd contour  
Check references on colour  
Different ways in order of masks and what colour first.

Spitfire Mk IXc No. 402 Squadron "City of Winnipeg"  
Flight Lieutenant Ian Keltie RAF England 1943

EN398



EN398

Check references on position and height of markings



Both sides of the fuselage. Check your references as to colour. First start with contour and paint white Weed leaf, apply transfer and insert circle. Mask off.

## Topside wings



1a Blue  
1b Red  
For 1a use 1ab contour

## Underside wings



10a Blue  
10b White  
10c Red  
For 10a use 10abc contour  
Different ways in possible order of masks and what colour first.

## Fuselage both sides



2a Yellow  
2b Blue  
2c White  
2d Red  
For 2a use 2abcd contour  
Check references on colour  
Different ways in order of masks and what colour first.

Spitfire Mk IXc No. 126 Squadron  
Squadron Leader Johnny Plagis RAF England 1944



Check references on position and height of markings

## Topside wings



1a Blue  
1b Red  
For 1a use 1ab contour

## Underside wings



10a Blue  
10b White  
10c Red  
For 10a use 10abc contour  
Different ways in possible order of masks and what colour first.

## Fuselage both sides



2a Yellow  
2b Blue  
2c White  
2d Red  
For 2a use 2abcd contour  
Check references on colour  
Different ways in order of masks and what colour first.

## MISCELLANEOUS

### Propeller

Weed and use transfer tape to position. Airbrush and afterwards insert circle. Mask off.

### Victory marks

Weed and use transfer tape to position. Airbrush and afterwards insert crosses. Mask off

EN398

ML214

MEMO  
MUSCAT

Weed and use transfer tape to position



For the fin flash: Use 'FF' as a template and mask of around. Remove the template and use the separate parts to airbrush the different colours.

# GENERAL INSTRUCTIONS

## DISCLAIMER

- Some symbols or markings may refer to NAZI or other extremist parties. These markings or symbols are being used for purely historical correctness. 1ManArmy wishes to express its deepest resentment for extremist and inhuman ideologies and does not intend to offend or to hurt.

## IMPORTANT

- For positioning of markings, squadron signs, numbers and letters, check the kit instructions or other references. Exact panel line positions or dimensions can differ slightly, according to the kit manufacturer.
- Visit the [1MANARMY.BE](http://1MANARMY.BE) website and check for the latest tips and tricks on FAQ.
- Use a magnifier, enough light, round tip tweezers and a sharp modelling knife/scalpel.
- Read the enclosed User Manual carefully, as it will help you understand its possibilities.
- The masking material is safe and is not susceptible to stretching or deformation and maintains its flexibility.
- Use a tootpick to adjust the mask to panel lines, indentations, corners, nooks and crannies.
- Leave the mask on the model no longer than 1 day. Remove the mask very slowly, in an unrolling way, using a 'untacky' corner.
- After weeding, use transfer tape. It's simple and avoids distortion. Cfr. User Manual.

## AIRBRUSHING

- Use the spare masks (marked with 'x') for prior testing, especially on how to airbrush the small stencils.
- Airbrush while keeping a consistent distance to the object and try different soft angles.
- **1 GOLDEN RULE:** Airbrush in thin and multiple layers, slowly building up the color. Avoid flooding the mask.
- For the small stencils always check with a magnifier, before removing the mask. When the mask turns black, your stencil is OK
- Use dark grey for the small stencils instead of black, giving a more natural appearance.
- Always first test your colours using some spare mask, as for instance the same blue, can look differently, having been painted on a light or on a dark underground. 1ManArmy recommends to airbrush "on top" of your paint, as in the old days. In order to assess your choice and combination of colours, simulate your mask colour on a piece of scrap, in order to determine the right colour or nuance.

## LEGEND:

- x: Spare masks for the small instruction stencils.
- a, b, c... Layered mask. Cfr. User Manual
- ?: Different stencil possibilities. Check your references
- TRIM: Adjust the mask according to the situation
- COL: Choose colour according to reference
- TRANSF: the use of transfer tape is very important
- OPT: additional maintenance stencils can be added, for missing panels on the kit





# USER MANUAL

I Man Army offers an innovating masking solution, making it possible to airbrush markings, squadron numbers and especially small instruction stencils on 1/32 scale aircraft models. The I Man Army airbrush paint masks will allow you to achieve a true 'painted-on' result and a dazzling and unique finish, thus obtaining a higher level of realism. Please read this manual carefully, as it will help you to fully understand the possibilities of this challenging new product. I hope it gives you new insights and sparks your creativity.

Kind regards and happy modelling

Sven

I Man Army

## PREPARING THE MASK

- Before removing the mask from the backing, place a 'marker' above the center of the stencil text. This will allow you to position/visualize the stencil part more easily, when placing it on the model.
- The reference number is always in the left lower corner and allows you to read/orientate the mask.
- Use a sharp tool to peel off the left lower corner and bend over the corner. A triangle of spare mask should be used to 'neutralize' the tacky underside. Use tweezers and slowly remove the mask. This corner will prove its added value once you have to remove the mask from the model, without damaging the paint.
- It may happen that some small parts/dots still have to be removed, after the mask has been detached. In that case gently place the mask on a solid surface without pushing it down. Carefully take away the excess parts using tweezers.

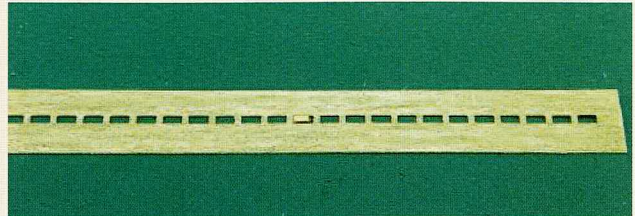
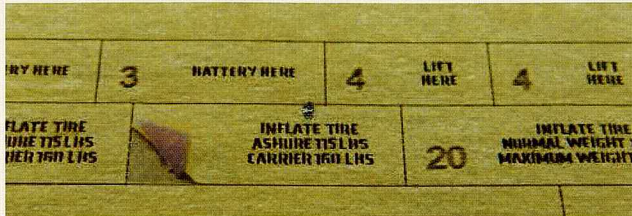

## PREPARING THE MODEL AND PLACING THE MASK

- A dry and clean surface is all that matters. No further preparation is needed.
- You can use a small 'spare' masking strip and mark the position on the strip, where the stencil marker has to be placed. This will help you determine position and angle. Multiple masks can be placed all over the model and airbrushed in one pass. Once well aligned with the 'guiding strip', gently push down the rest of the mask, using an intermediary piece of paper.
- Avoid touching the small stencils directly with your fingers. Push down the mask using a piece of paper. This will avoid 'rubbing' and damaging the small stencils. Check if the mask is well pushed down, using a magnifier.
- Once set and pushed down, avoid repositioning the mask, as this may damage the very small stencils.

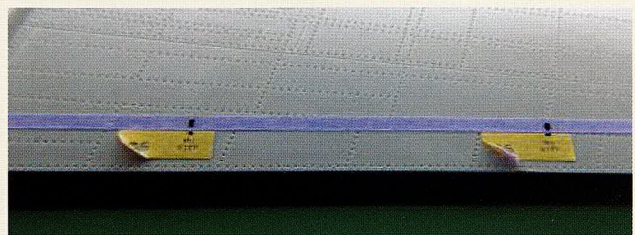

## SYMMETRY AND ALIGNMENT

- Place a yellow text mask or any mask on one wing/side. If you want to copy that exact position to the other side, make a random masking tape triangle and align it to the mask. Use panel lines and other parts of the model to place reference markers on the triangle. Turn the triangle upside down and position it on the opposite side, using the same references. Align the markers with the references, and you will see where you have to position the opposite mask.



RIGHT WING



RIGHT WING

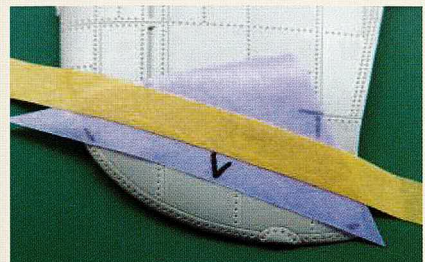

LEFT WING

MASK, AIRBRUSH AND READY





# USER MANUAL

- **IMPORTANT:** First use the spare masks to gain some experience. Spare masks are marked on the masksheet with X.
- Carefully mask off the surrounding area to avoid overspray and check before airbrushing.
- Do not forget to mask off the 1ManArmy-reference number in the left lower corner of the mask.
- Use low pressure and keep the same distance ( 8 cm or +/- 3 inch ) from the mask. Different soft angles will help to seal all edges.
- **ONE GOLDEN RULE:** Build up the color in very light layers, which will help seal the edges and NEVER flood the mask!
- Important: pushing down the small stencils correctly will determine the sharpness of the paint job.
- Using, in between layers, the airflow of the airbrush or a hairdryer will help. Use a magnifier to check the result  
When the yellow mask has turned entirely black, the result should be fine. If some yellow is still visible, keep adding layers.
- Use dark grey for the small stencils, giving a more natural and weathered 'appearance' than harsh black.

## COMPLEX MASKS

- Some stencils, within the same mask, may need different colors. Avoid taping over the text parts. This may harm the stencils.  
Use a small piece of paper to 'un-glu' the small part covering the text part.

## THE IMPORTANCE OF TRANSFER TAPE

- For most large masks 'transfer tape' will always be very helpful. Transfer tape will strengthen the mask, keep it in shape and avoid deformation, when placing on the model. Transfer tape can be described as ordinary low tack masking tape which is positioned on the airbrush mask. Any low-tack masking tape will do. Do not use transfer tape on small text stencils, unless you protect/unglue the stencil part.

- 1 Prepare your mask and remove the part that has to be airbrushed.
- 2 Place some 'spare' masking tape ( = transfer tape ) on the mask you need, covering all the relevant parts. Push down.
- 2 Keep the transfer tape within the dimensions of the mask, you need.
- 3 Place the mask on the model using the guiding strip and marker. Press down softly.
- 5 Slowly remove the transfer tape. Ready.

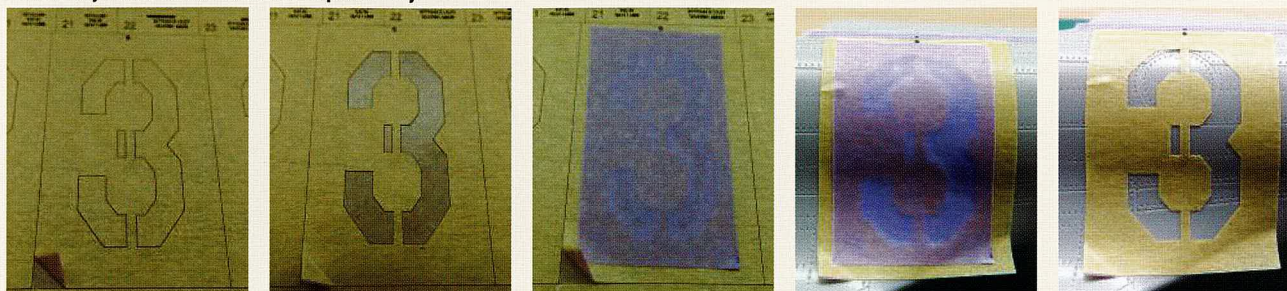

## USING LAYERED MASKS

- In some cases masks may have to be superposed. These masks are marked with a/b/c/d.
- Start with the a-mask. Leave it on the model the entire process. Darken/color the corners of layer a, while still on the backing.
- Check your references and airbrush the corresponding color for mask a.
- Allow to dry and place mask b on top of a. Important that corners match! Use tweezers and take your time! Then airbrush mask b.
- If necessary, remove mask b and replace by mask c, always respecting the exact overlap and so on.
- Here again the 'neutralized' corner will make the positioning and peeling-off afterwards easy.
- Use transfer tape on all layers. Darkening 3 of the corners of layer a will clearly show the correct superposition/contrast, when positioning another yellow layer on top.

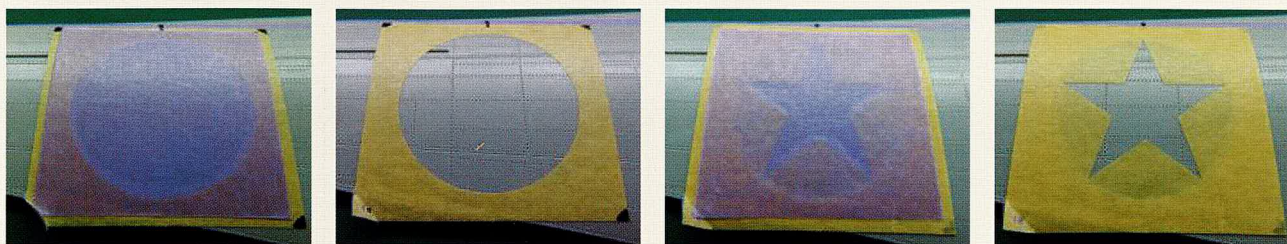

Layer a with transfer tape

Layer a

Layer a + layer b with transfer tape

Layer a+b

## REMOVING THE MASK

- The mask can stay in place, after airbrushing, for up to a couple of days and will peel off easily. No residu will remain.
- Never leave masks on for more than 1 day. Temperature, humidity and UV can affect the adhesive. It is better to remove after painting.
- Always check the paint result with a magnifier before removing the mask.
- Use tweezers and very slowly remove the mask, always using the same 'neutralized' corner.

## LAST DETAILS

- Weathering, fading and chipping are now possible. If necessary, you can sand using a very fine grit.

Always check the FAQ page on the website, as it contains the latest and updated tips and tricks.