

Marking & Painting

マーキング及び塗装
Markierungen und Bemalung

Decoration et Peinture
Marchio & Pittura

Decoracion y Pintura
標貼及着色指示

1 ドイツ空軍 (アフリカ軍団)
Assigned to German Air Force (African Division)

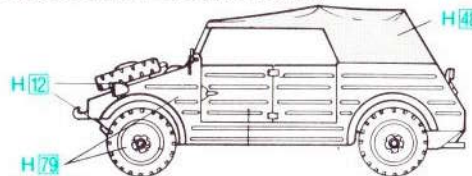

2 ドイツ親衛隊
Assigned to German Bodyguard (Schutz-staffeln)

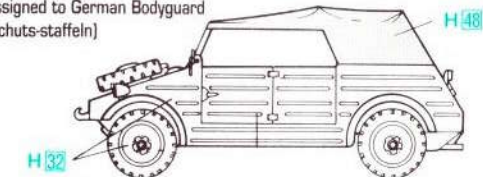

3 ドイツ国防軍 (アフリカ軍団)
German National Defense Force (African Division)

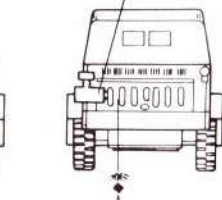
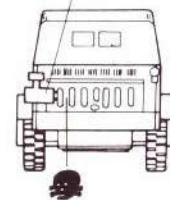
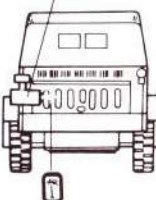
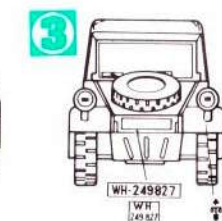
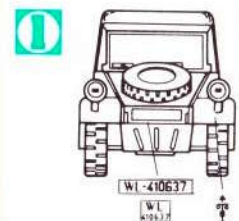
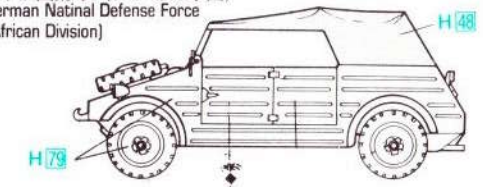

1
2
3

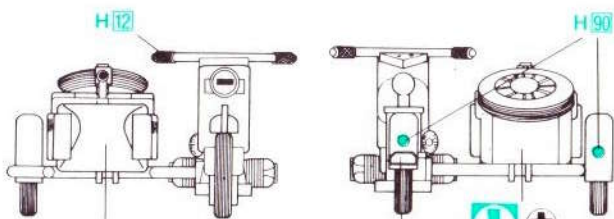
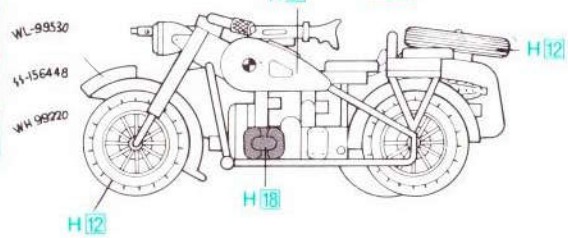

1 WL 99530
2 SS 156448
3 WH 99220

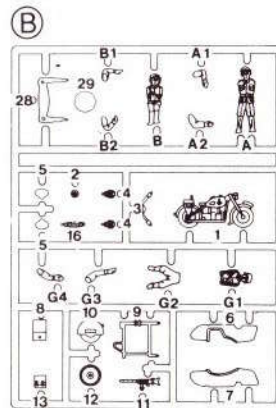
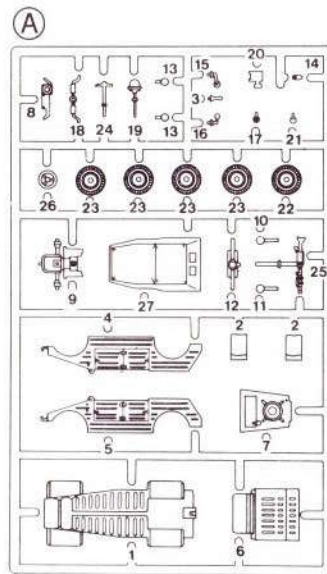
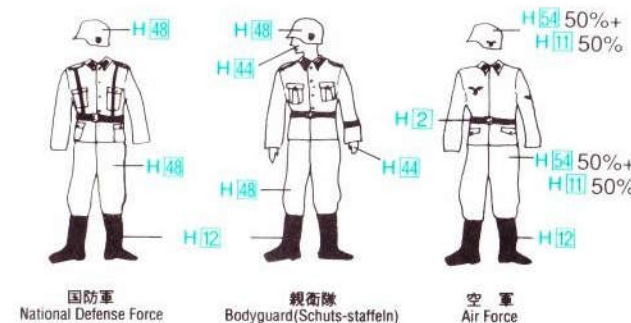

■部品及びデカールを紛失したり、破損した場合は実費でおわけします。
料金及び送料については、当社サービス係までお問い合わせください。

棟長谷川製作所 静岡県焼津市八幡1193-2 千425 TEL (054) 628-8241
HASEGAWA SEISAKUSHO CO.,LTD 1193-2 Yagusu, Yaizu, Shizuoka, 425 Japan.

©PRINTED IN JAPAN. 1991.11(P)

KÜBELWAGEN/B.M.W. SIDE CAR



MT12 1:72 キューベルワグゲン/B.M.W. サイドカー



《キューベルワグゲン》
キューベルワグゲンは、フェルデナンド・ポルシェ氏が1938年に設計したフォルクスワーゲンを基本車体として製作されたもので、生産台数を増加させるため簡単な構造をしています。キューベルワグゲンは数千台が大戦中に生産され、ほとんどすべての地域で偵察や連絡に活躍、作戦を成功させる役割をはたしました。
《データ》 全長: 3.73m 全幅: 1.60m 全高: 1.65m エンジン: 空冷水平対向4気筒1,131c.c. 最高速度: 85km/h
《B.M.W R75サイドカー》
オートバイ部隊はドイツ陸軍の機械化部隊の主役として第2次大戦が始まるやいなや、その機動性を生かして活躍しました。ツェンダップ、NSU,DKW,など多くのオートバイがドイツ軍に使われ、大型の500c.c.以上のものには標準型のサイドカーも付きました。中でもBMW R75は高い信頼性と頑丈なボディをもち大戦を通じ終始伝令や偵察に走りまわると同時に、サイドカーを取付け各戦線で攻撃の先鋒としても活躍、特に北アフリカでは多数が使用されました。
《データ》 全長: 2.40m 全幅: 1.73m 全高: 1.00m エンジン: BMW水平対向2気筒746c.c. 最高速度: 95km/h (カー付)

(Kübelwagen)
Like the U.S. Willys Jeep, Kübelwagen was one of the famous light vehicles during the World War II. It was designed by Ferdinand Porsche in 1938, using the basic chassis of the Volkswagen. For mass production, this was entirely of simple structure. Several thousands were produced during the war, seeing service in all areas as reconnaissance and liaison capacity, and played a great part of the success in the warfare.
(DATA)
Length: 3.73m Width: 1.60m Height: 1.65m Engine: Air-cooled horizontal counter 4 cylinder, 1,131c.c. Max. speed: 85 km/h (B.M.W. R75 Side-Car)
From just the beginning of World War II, the motorcycle outfit in the German army played the leading role in its mechanized unit. By making use of its mobility, Zündapp, NSU, DKW and other types of motorcycle served for the German military force. On the motorcycle over 500 c.c. the side-car was installed. The BMW R75, for its reliability in engineering and sturdy chassis, served throughout the war as a reconnaissance and liaison capacity.
(DATA)
Length: 2.40m Width: 1.73m Height: 1.00m Engine: BMW horizontal counter 2 cylinder, 746 c.c. Max. speed: 95 km/h (with side-car)

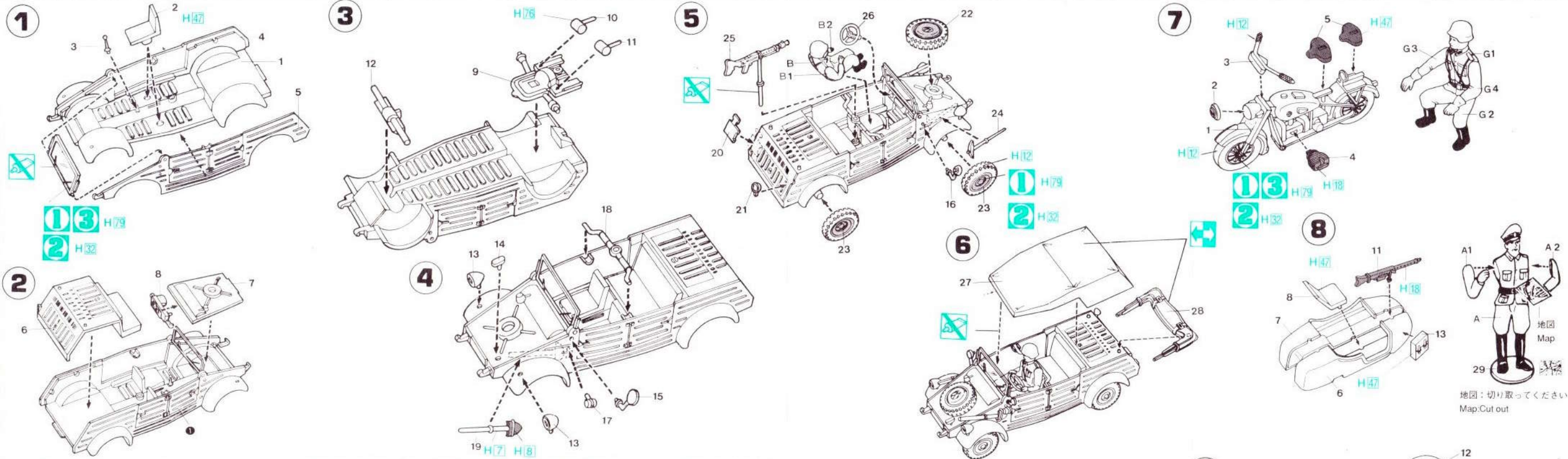

接合しないでください DO NOT CEMENT / NON INCOLLARE NO PEGAR / NICHT KLEBEN / NE PAS COLLER
 どちらかを選んでください FACOLTATIVO OPCIONAL / OPTIONAL NACH BELIEBEN / FACULTATIF
 塗装図の番号です PAINTING SCHEME NUMBER / LACKIERSCHEMANUMMER / NUMEROS DE LA LISTE DE PEINTURES
 NUMERO DELLO SCHEMA DI VERNICIATURA / PINTAR ESQUEMA NUMERO / 這是塗裝圖的號碼

塗料指定のH□はGunze産業・水性ホビーカラー、■はMr.カラーの番号です
 このキットには接着剤は入っていませんので別にお求めください

H□ in painting indication is the number of Gunze Sangyo Aqueous Hobby Color, while ■ is that of Mr. Color. Glue is not included in this kit.

H□ nella indicazione della pittura è il numero della Gunze Sangyo del colore ad acqua per Hobby, mentre ■ è quello di Mr. Color. La colla non è inclusa nella scatola di montaggio.

Sur le guide de peinture, H□ correspond au numero de couleur GUNZE SANGYO AQUEOUS HOBBY COLOR, alors que ■ correspond à Mr. COLOR. La colle n'est pas fournie dans ce kit.

H□這個着色指示是代表都是出品水性模型漆的編號，而■則代表都是出品的樹脂系模型漆的編號，這份零件並沒有包括膠水。

H12	2	ブラック	BLACK	SCHWARZ	NOIR	NERO	NEGRO	黒色
H7	7	ブラウン	BROWN	BRAUN	MARRON	MARRONE	MARRON	啡色
H8	8	シルバー	SILVER	SILBER	ARGENT	ARGENTO	PLATA	銀色
H11	32	つや消しホワイト	FLAT WHITE	MATTWEISS	BLANC MAT	BIANCO OPACO	BLANCO MATE	啞白色
H12	32	つや消しブラック	FLAT BLACK	MATTSCHWARZ	NOIR MAT	NERO OPACO	NEGRO MATE	啞黒色
H18	32	黒鉄色	STEEL	STAHL	ACIER	ACCIAIO	ACERO	黒鐵色
H32	32	フィールドグレー (1)	FIELD GRAY (1)	FELD GRAU (1)	GRIS DES TROUPES ALLEMANDES (1)	GRIGIO CAMPO (1)	GRIS COMPANIA (1)	田灰色 (1)
H14	31	はだ色	FLESH	FLEISCHFARBE	CHAIR	COLOR CARNE	CARNE	肌肉色
H47	41	レッドブラウン	RED BROWN	ROT BRAUN	MARRON ROUGE	MARRONE ROSSICCO	MARRON ROJO	紅褐色
H48	32	フィールドグレー (2)	FIELD GRAY (2)	FELDGRAU (2)	GRIS DES TROUPES ALLEMANDES (2)	GRIGIO CAMPO (2)	GRIS COMPANIA (2)	田灰色 (2)
H5	12	ネイビーブルー	NAVY BLUE	MARINEBLAU	BLEU MARINE	BLU MARINA	AZUL ARMADA	海軍藍
H70	61	焼鉄色	BURNT IRON	GEBER, EISEN	FER BRULÉ	FERRO BRUCIATO	HIERRO BRUNIDO	燒鐵色
H79	33	サンディイエロー	SANDY YELLOW	SANDGELB	JAUNE SABLE	SABBIA	AMARILLO ARENA	深黃色
H90	47	クリアレッド	CLEAR RED	ROT, REIN	ROUGE CLAIR	ROSSO CHIARO	ROJO CLARO	透明紅色

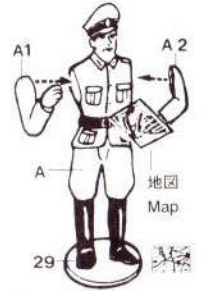
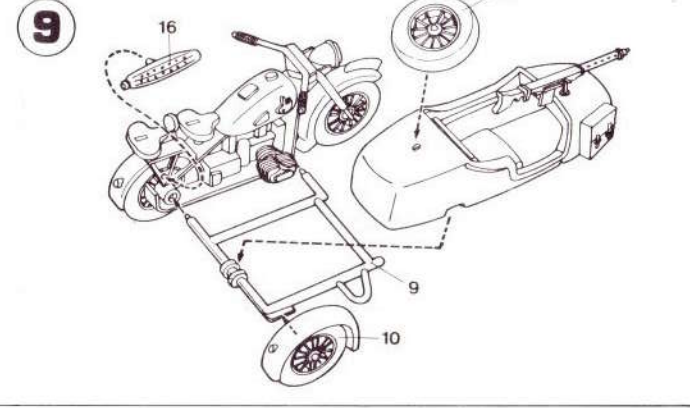

地図：切り取ってください
 Map: Cut out

WL
410637

WL-410637

wh-99220

wh-99220

wh-99220

wh-99220

WH
249827

WH-249827

wh-99530

wh-99530

wh-99530

¥¥ - 51000

wh-156440

wh-156440

wh-99530

¥¥
510000



**MADE IN
JAPAN**