

B-29A Superfortress



The B-29A was employed as a long-range heavy bomber to bomb the Japanese mainland from distant bases in China and the Pacific islands. The B-29A was the first aircraft to deliver an atomic bomb in 1945 and served well into the 1950's for both the United States Army Air Force and the United States Air Force.

Markings included in this kit are

USAF, 19BG, 30BS, Kadena AB, Okinawa, Fall, 1950.

Royal Air Force, No.15 Sqn, Germany, 1951

Royal Australian Air Force, Australian R&D Unit, mid-1950

Minicraft Models, 1501 Commerce Drive, Elgin IL 60123 USA

www.minicraftmodels.com

Printed in China

Your MINICRAFT B-29 may be assembled with various options, such as 'In-flight' features as retracted landing gear and 'spinning' propeller. Parts are also provided for a 'stationary' or 'ground' version with extended landing gear. Please review the assembly steps to become familiar with the parts before beginning assembly.

PARTS LAYOUT DIAGRAM

NOTE ≠ Aircraft used for training and operational atomic bomb missions had all turrets and sighting blisters removed and faired over. Tail guns were carried.

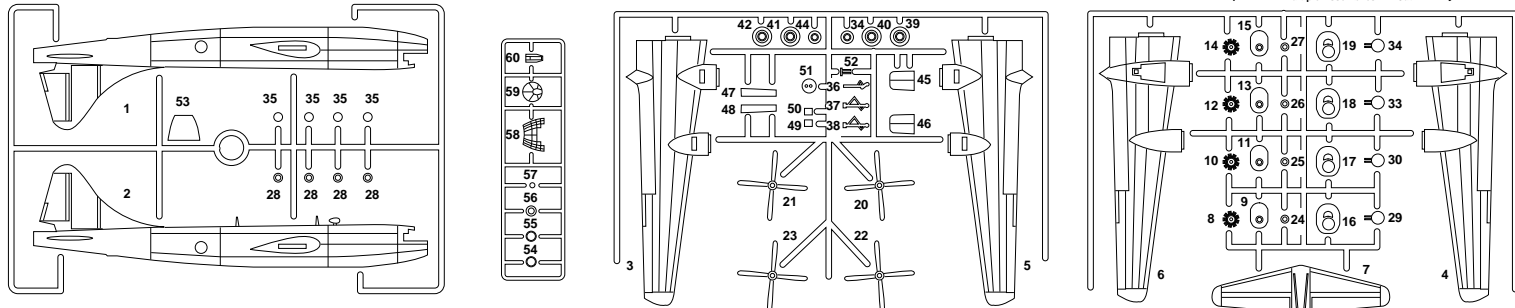

1 ? 4X 29/30/33/34 35 Finished Assembly

Omit strut 36 and nose weight for 'in-flight' version

All Parts except as noted

Cockpit Interior ≠ FLAT BLACK
Gun Barrels ≠ GUNMETAL
Nosewheel strut ≠ ALUMINUM

2 All Parts

3 All Parts

9/11/13/15 16/17/18/19

4X 8/10/12/14 4X

Cylinders ≠ METALLIC GRAY

STATIONARY VERSION ? IN-FLIGHT VERSION

20/21/22/23 28 24/25/26/27

Propeller Blades ≠ FLAT BLACK with YELLOW tips
Propeller Hubs ≠ ALUMINUM

4 All Parts

Cockpit floor ≠ FLAT BLACK

5 All Parts

Tailgun barrels ≠ GUNMETAL

Note orientation of nose cap (part 59)

6 All Parts

IN-FLIGHT VERSION

7 All Parts

STATIONARY VERSION

Cut parts 45/46 in two

Struts, hubs and wheelwells ≠ ALUMINUM
Tires ≠ FLAT BLACK-GRAY

USAF, 19BG, 30BS, Kadena AB, Okinawa, Fall, 1950

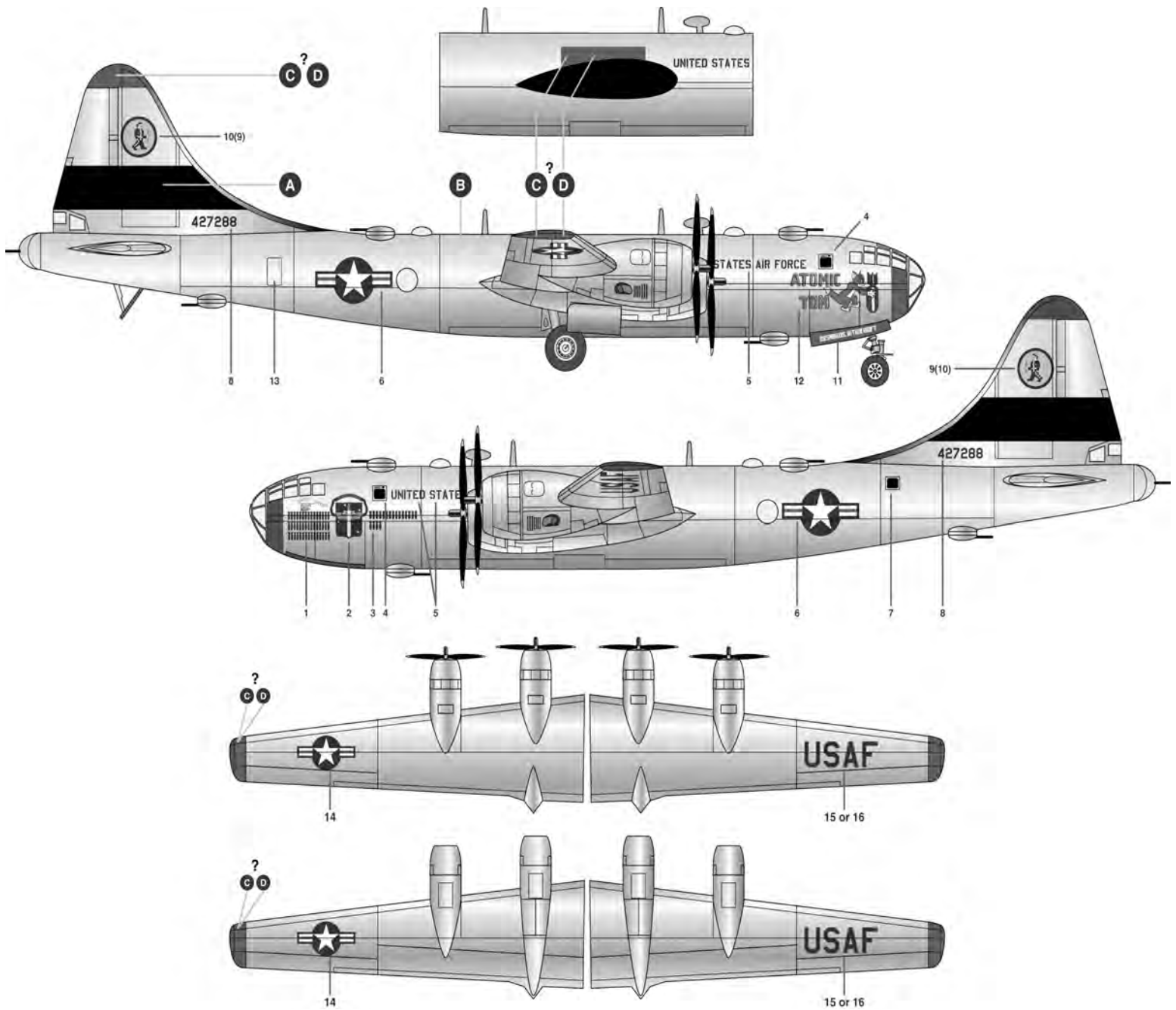

PAINTS

A Black (ModelMaster 1749, Acryl 4768)

B Aluminum (ModelMaster 1781, Acryl 4677)

C FS15102 True Blue (ModelMaster 2030) - or -

D FS35044 Insignia Blue (ModelMaster 1719, Acryl 4742)

Royal Air Force, No.15 Sqn, Germany, 1951

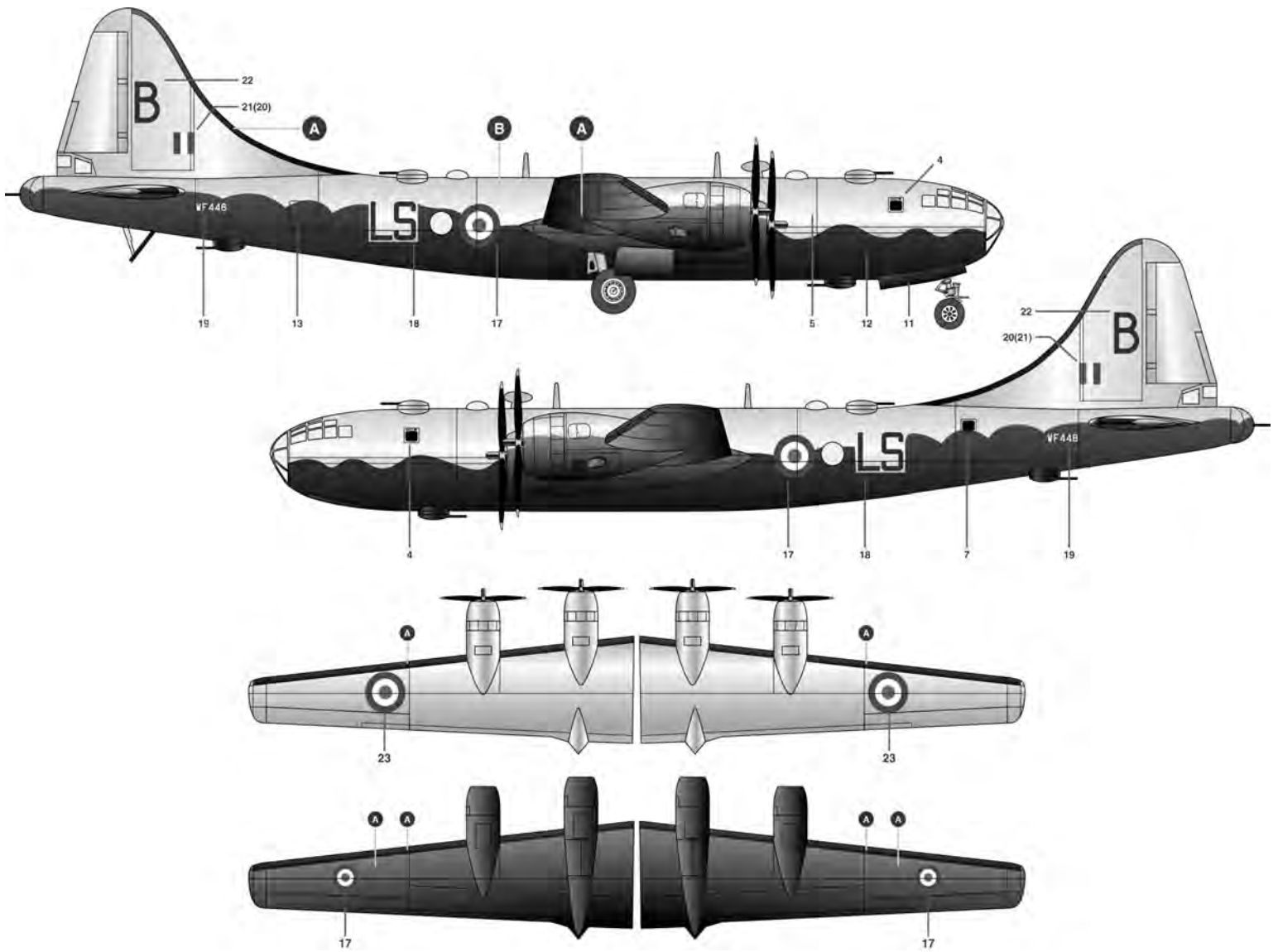

Royal Australian Air Force, Australian R&D Unit, mid-1950's

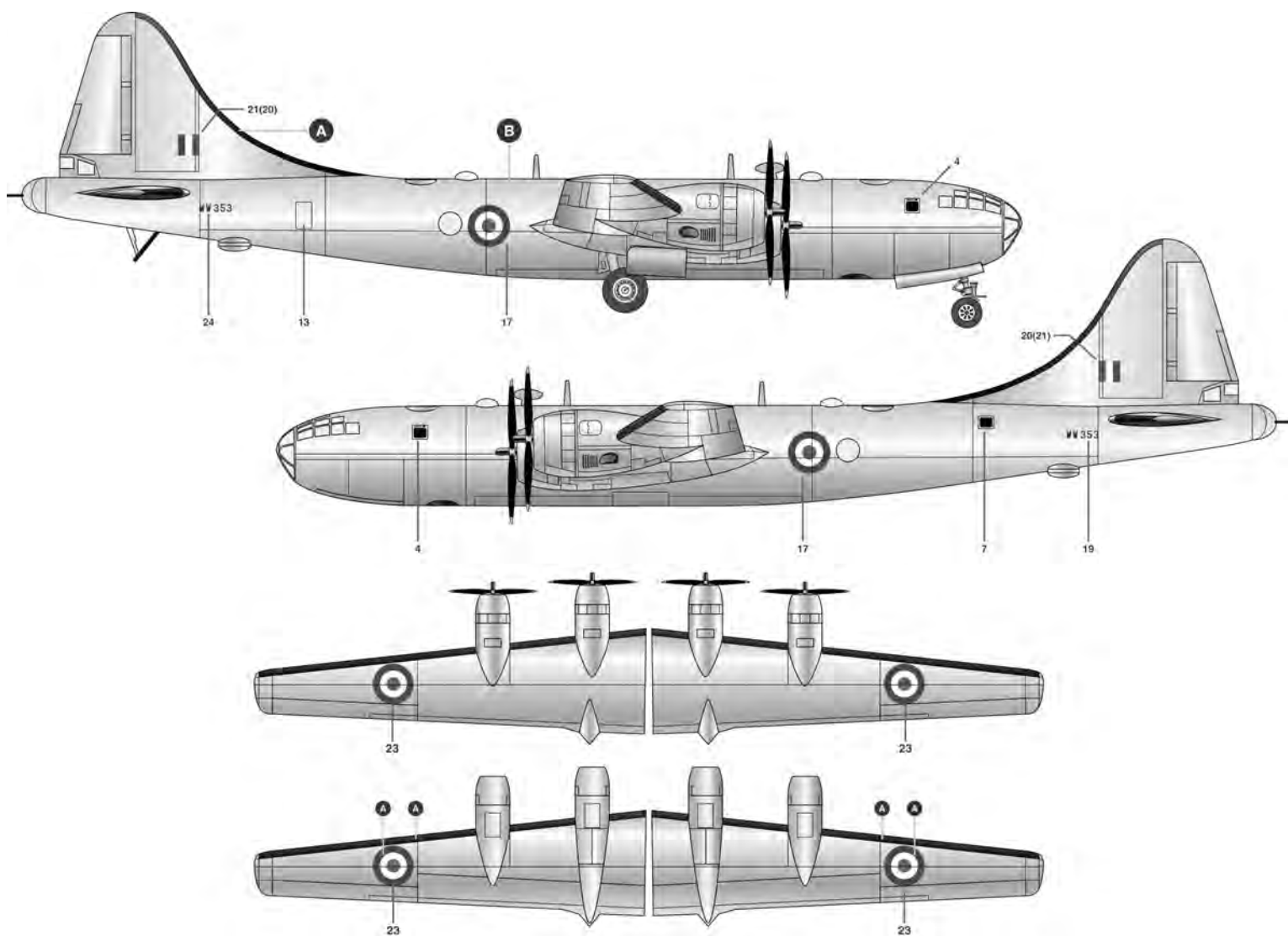



Legends in the making™

Minicraft Models
1501 Commerce Drive
Elgin, IL 60123 USA

Visit our Website-
www.minicraftmodels.com

Printed in China