

Q F-104G

ROC AIR FORCE STARFIGHTER
中華民國空軍 公洞四戰鬥機

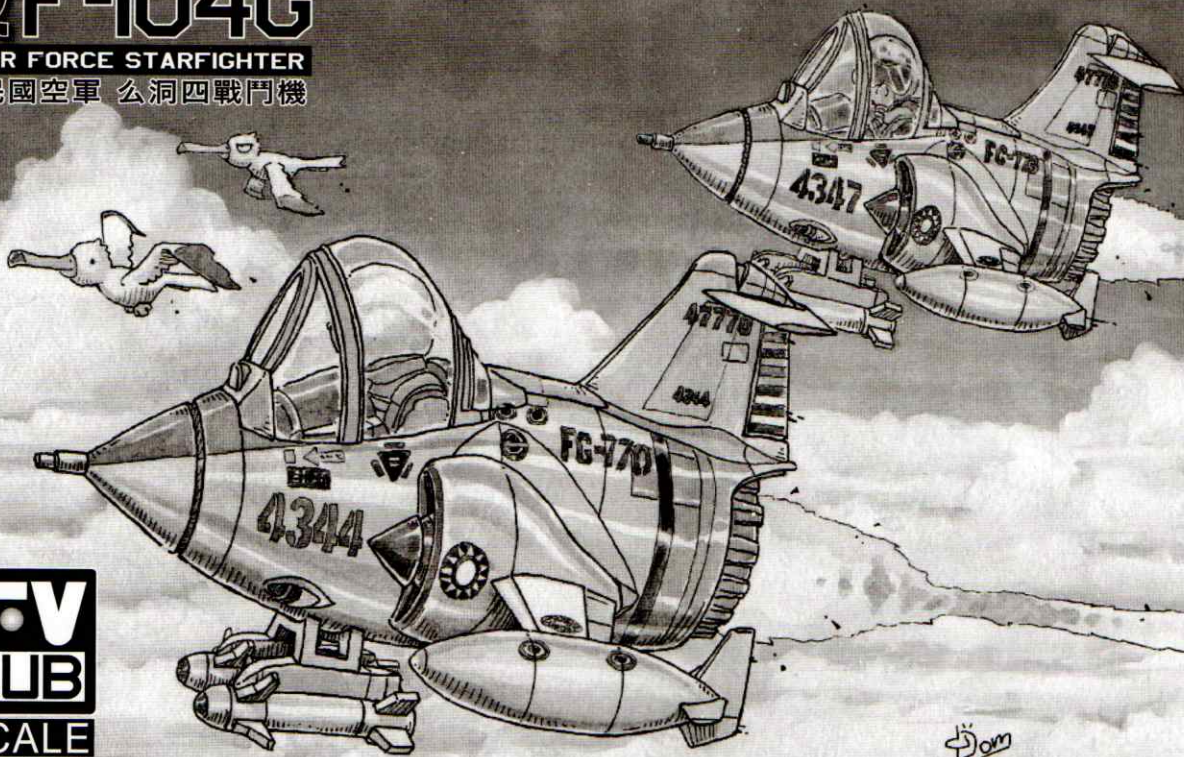

**AFV
CLUB**
QSCALE
AFQS04

F-104星式戰鬥機是世界上第一架擁有兩倍音速的戰機。

外型非常特別，採用了小展弦比梯形翼，高平尾布局(T形尾翼布局)。

總計生產了2,580架各型F-104戰機，使用國共計15國。

最後一個使用國家義大利於2004年12月將所有的F-104退出現役後，正式結束星式戰鬥機超過50年的服役生涯。

The F-104 Starfighter was the first combat aircraft capable of sustained Mach 2 flight.

The appearance is very special, equipped with razor-edge thin-blade supersonic wings and "T-tail" empennage.

Totally 2,580 of F-104 fighters were produced on US or other countries and service in 15 countries.

The Italy's last Starfighters in combat service, the F-104S-ASA/M was decommissioned in December 2004, the Starfighter ended more than 50 years of career.

水貼紙使用說明：

(初次貼水貼可先用其他物件練習，等熟悉了再正式貼)

- 1.組裝及上色結束後,最後才貼水貼紙
- 2.將模型表面擦乾淨
- 3.將貼紙依需要的部分剪下
- 4.用微溫的水泡濕貼紙,約15秒後取出
- 5.將貼紙放在想貼的位置旁邊
- 6.用指尖輕推貼紙表面,讓貼紙滑出底紙
- 7.在水乾之前將貼紙調整至適當位置
- 8.輕輕擦去水份,等到自然乾燥後即完成

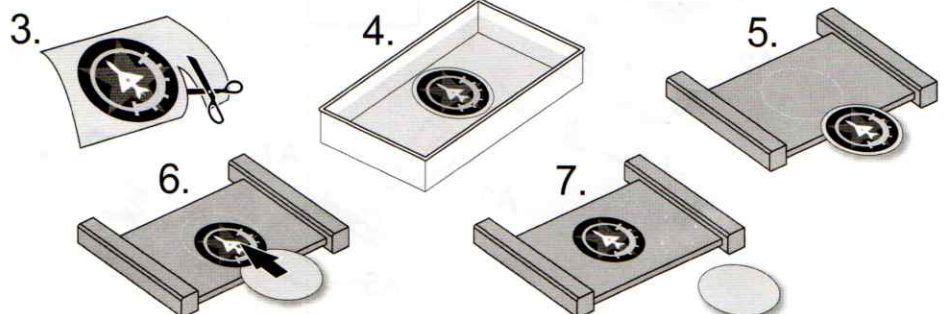

1

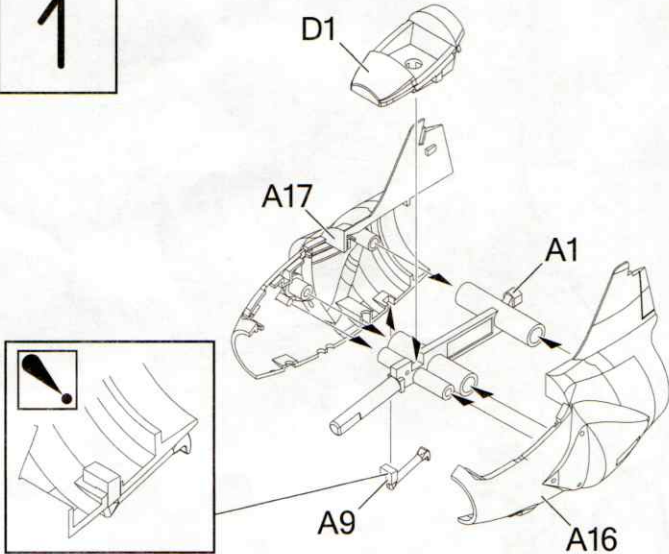

2

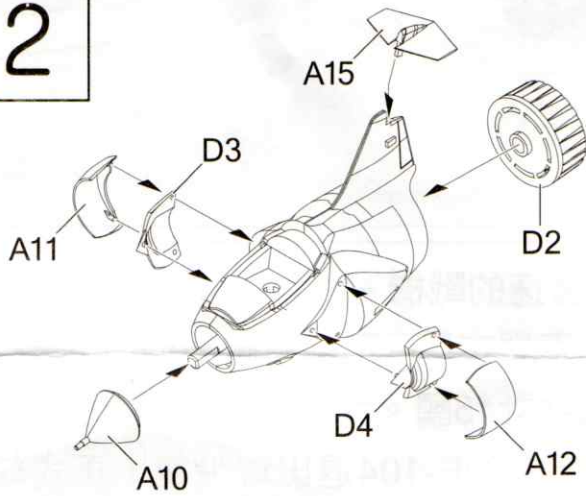

3

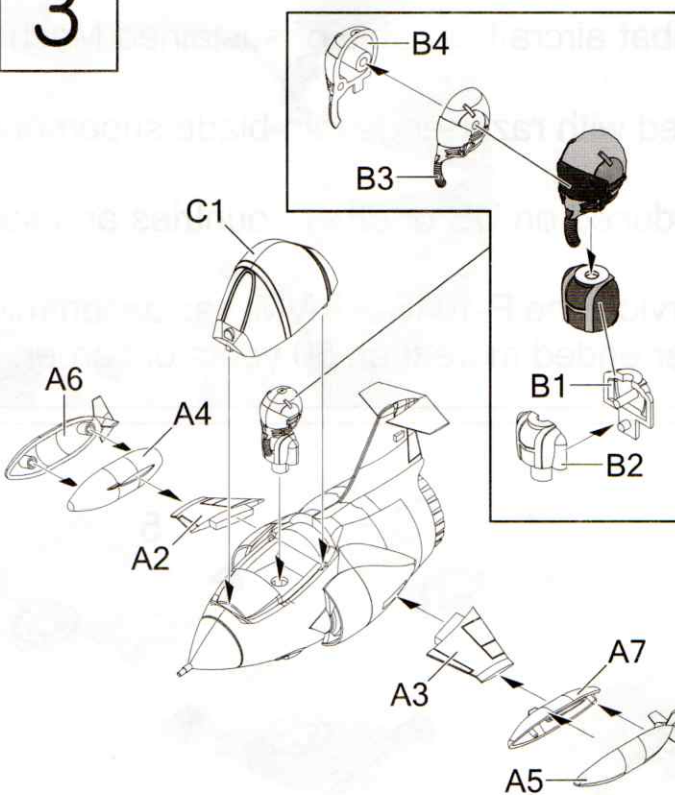

4

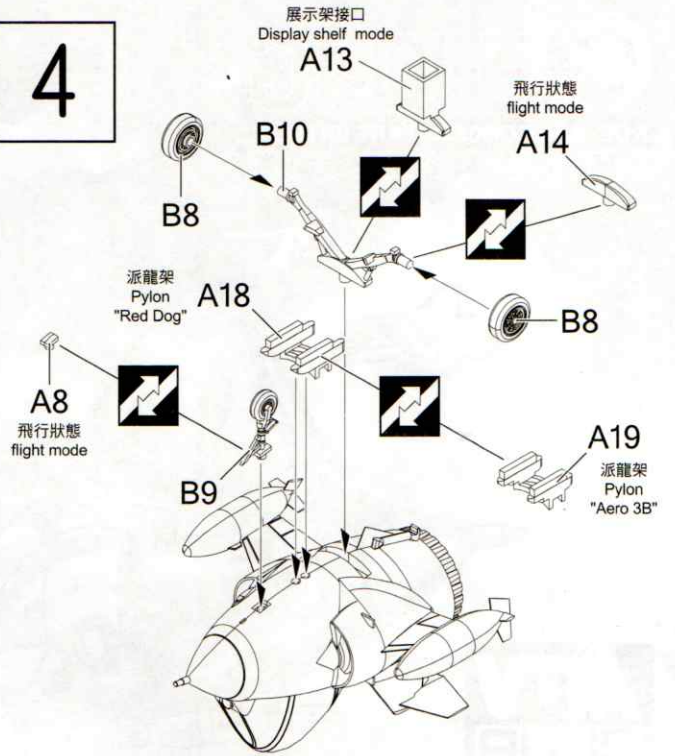

5

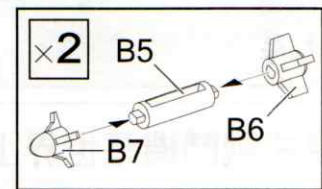

6

