

USAF / IAF C-130J-30 Conversion set

For Italeri C-130J kit

Resin parts

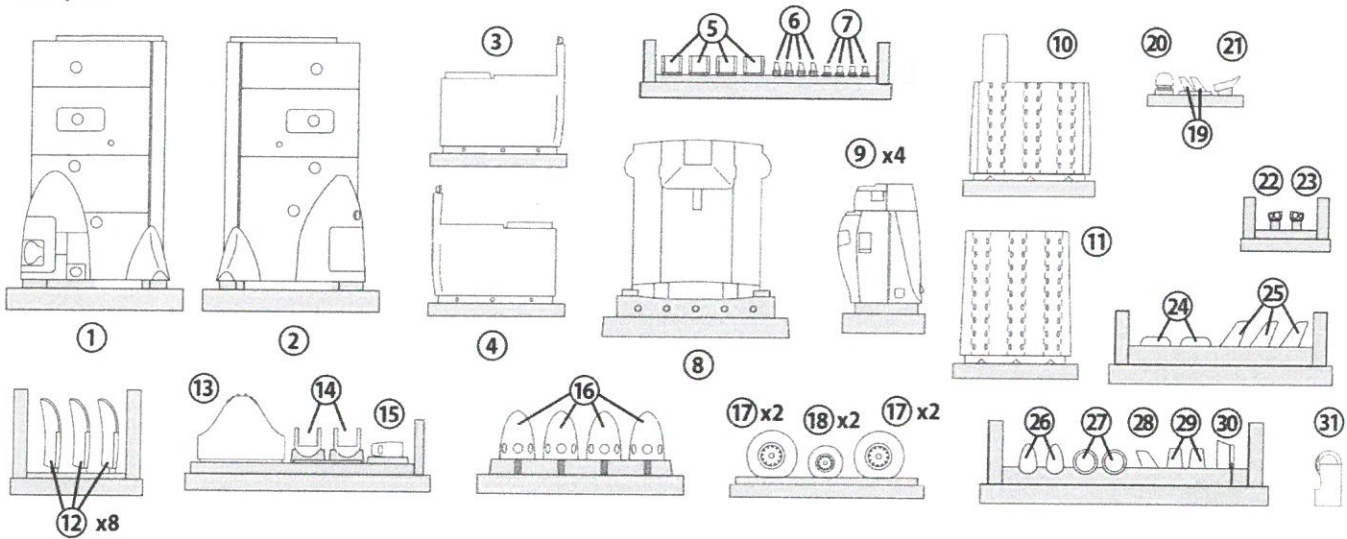

Assembly Instructions

The conversion is set to convert the short C-130 of Italeri to the stretch version of the plane - C-130J-30.

Basically the assembly of the kit is as shown in the kit instruction except issues that shown here and need to be done in the right building steps.

1. Assemble kit parts as seen in step one of the kit instructions.
2. Before step 2, cut the following parts exactly as shown here.

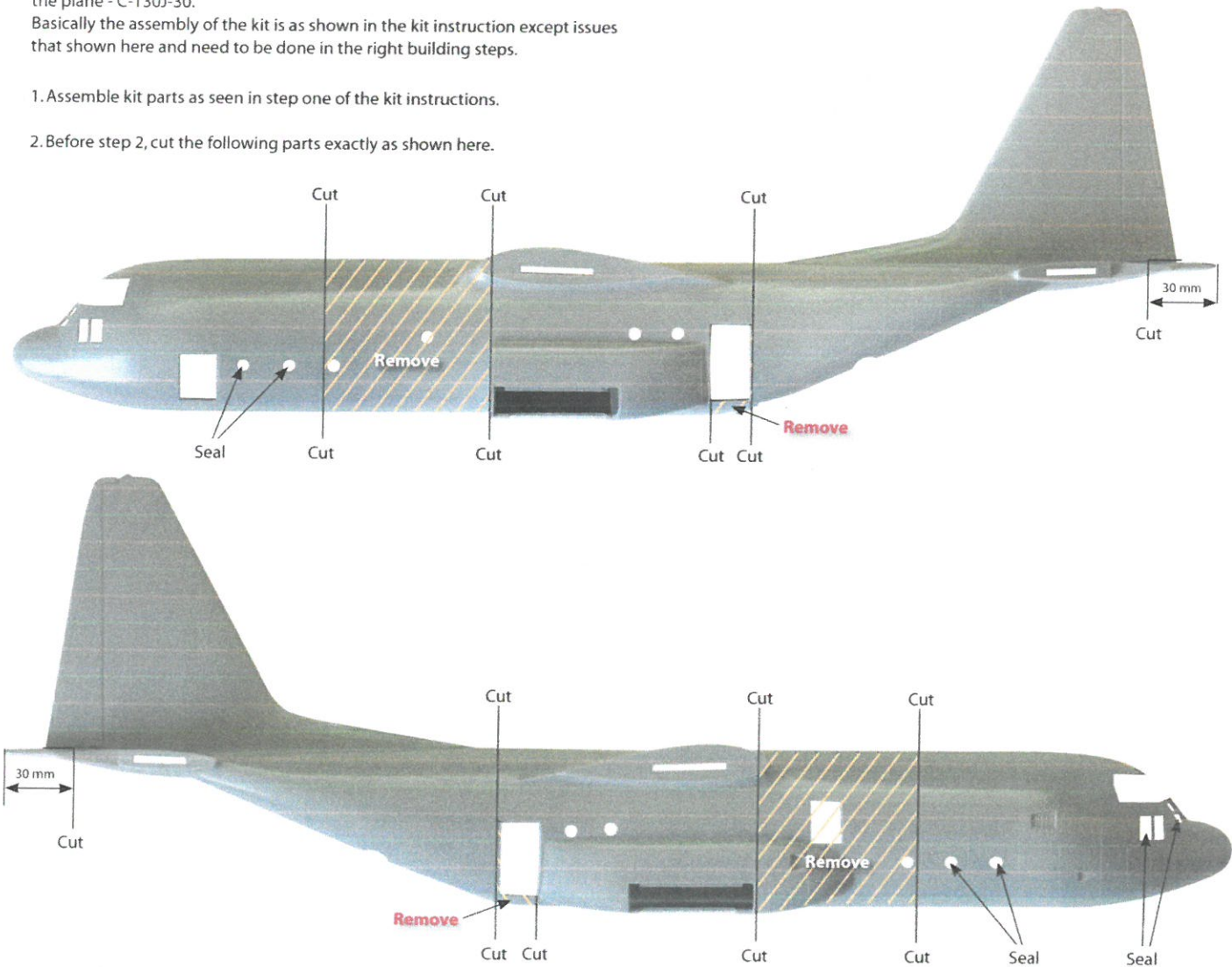

Install the fuselage plugs. Install the rear side entrance doors for better fit of the rear plugs.

Glue windows 23E in their new location as well as 2E windows. Locate windows 26E, 27E, 44E and 45E. Seal the relevant windows with filler.

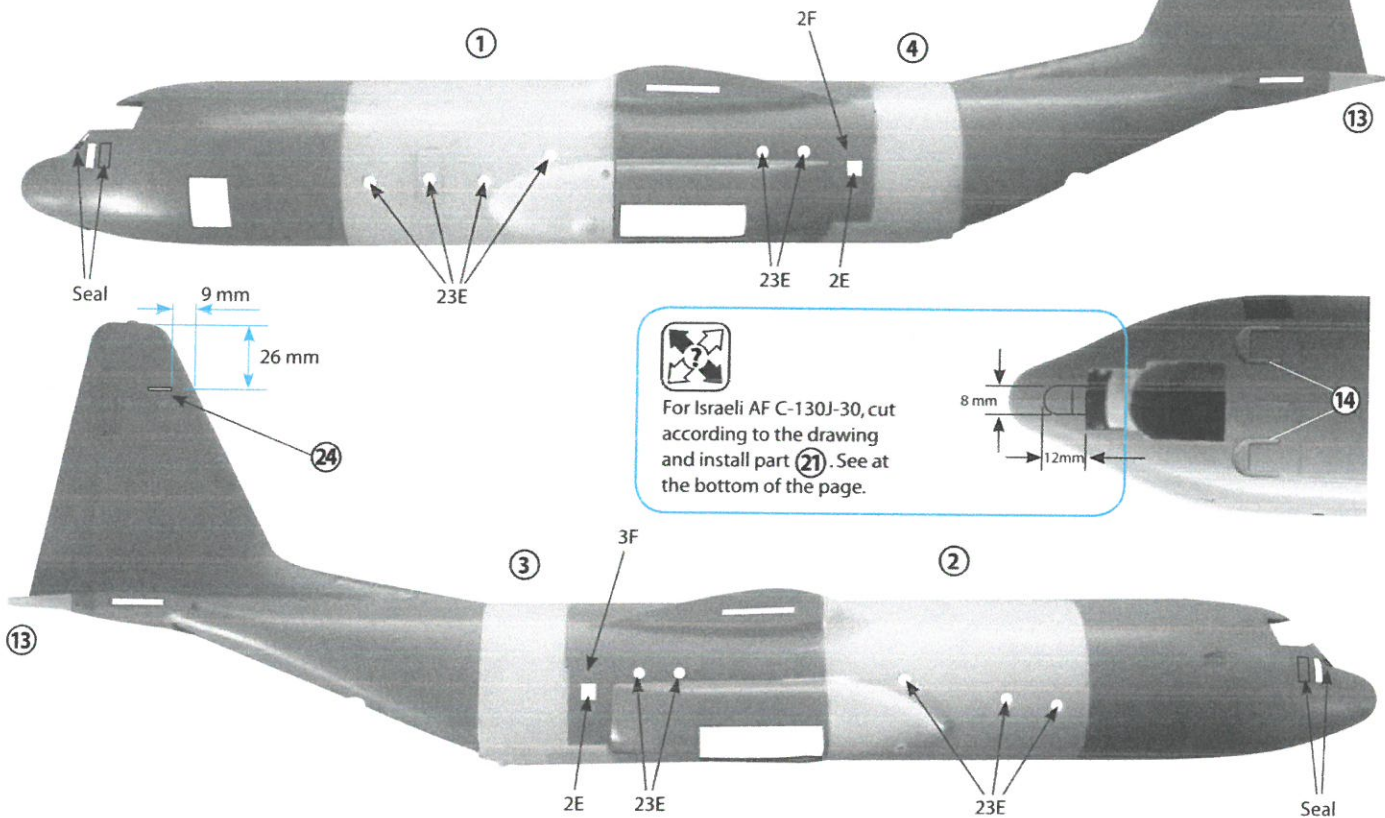

Steps 2-3: Install landing gear bays.

Step 4: If you wish to install the inner cargo floor, cut part 35A as seen on the right and attach parts ⑩ and ⑪ as shown below.

For the lower ramp door use part ⑧ instead of part 47C.

Step 5: Use part ⑬ instead of 7F, 8F, 20F, 19F and 25F.

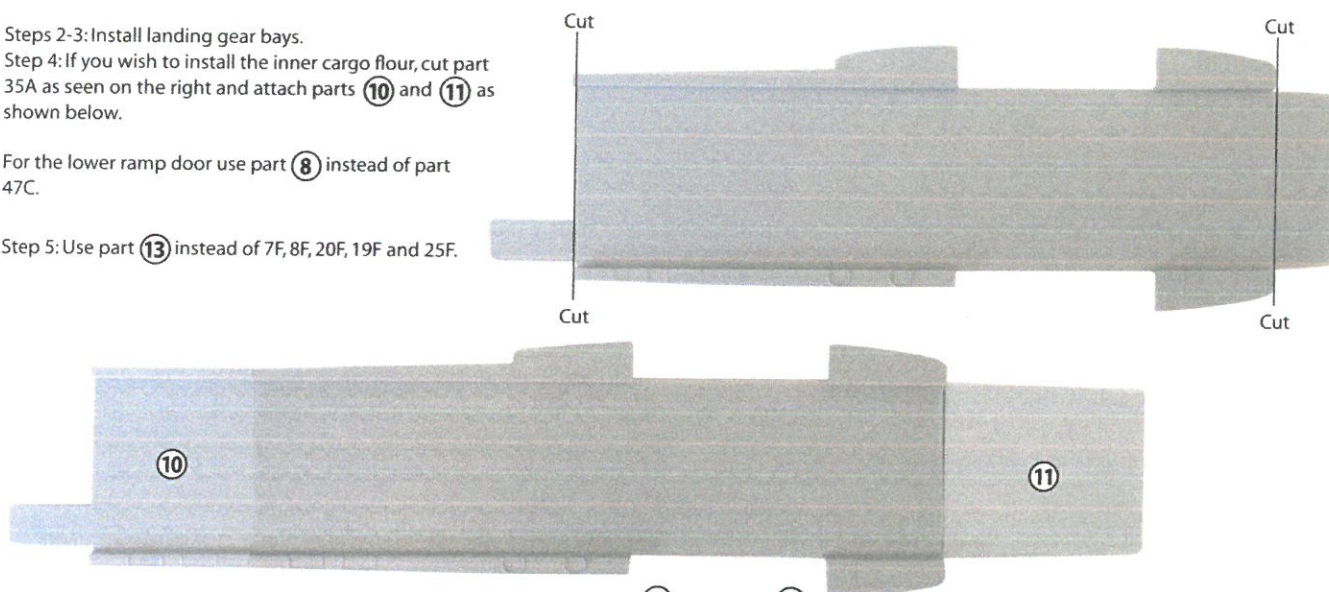

Step 6: Use the conversion wheels (⑰ and ⑱) instead the part provided by Italeri.

Install part ⑮ instead of part 14F.

Install parts ⑳ and ㉓.

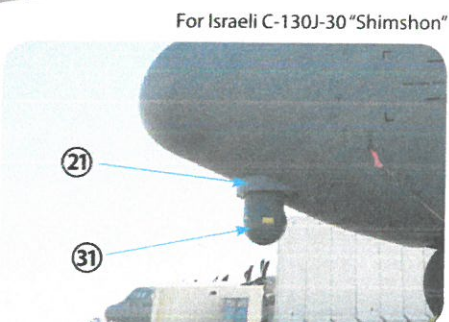
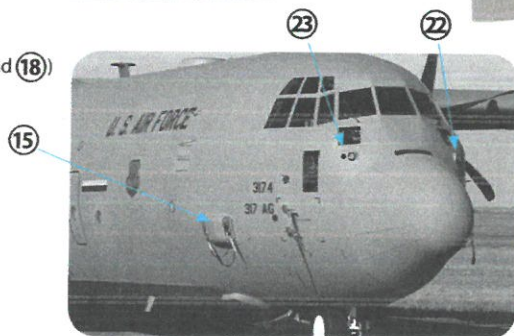

Step 7: Install the engines from the conversion set instead the parts from Italeri.
Assemble the rest of the parts as shown.

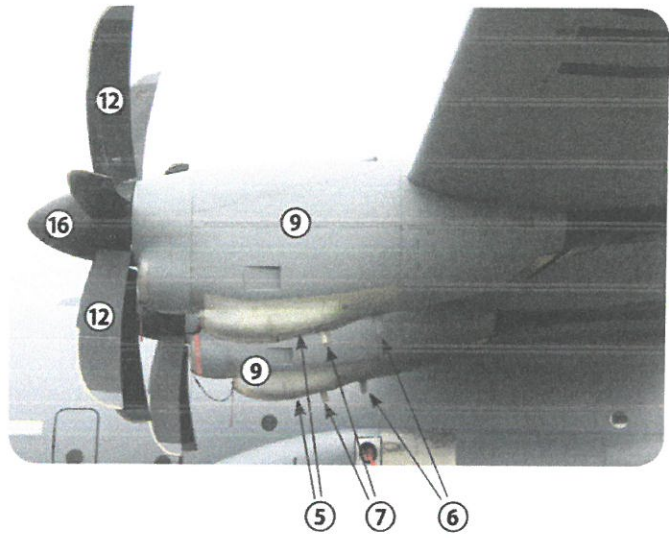
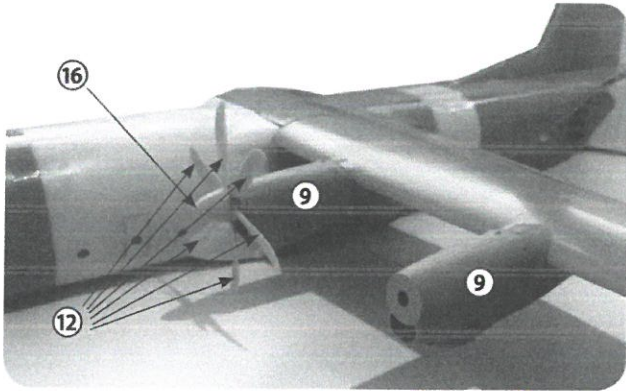

USAF - C-130J-30 Aerials location

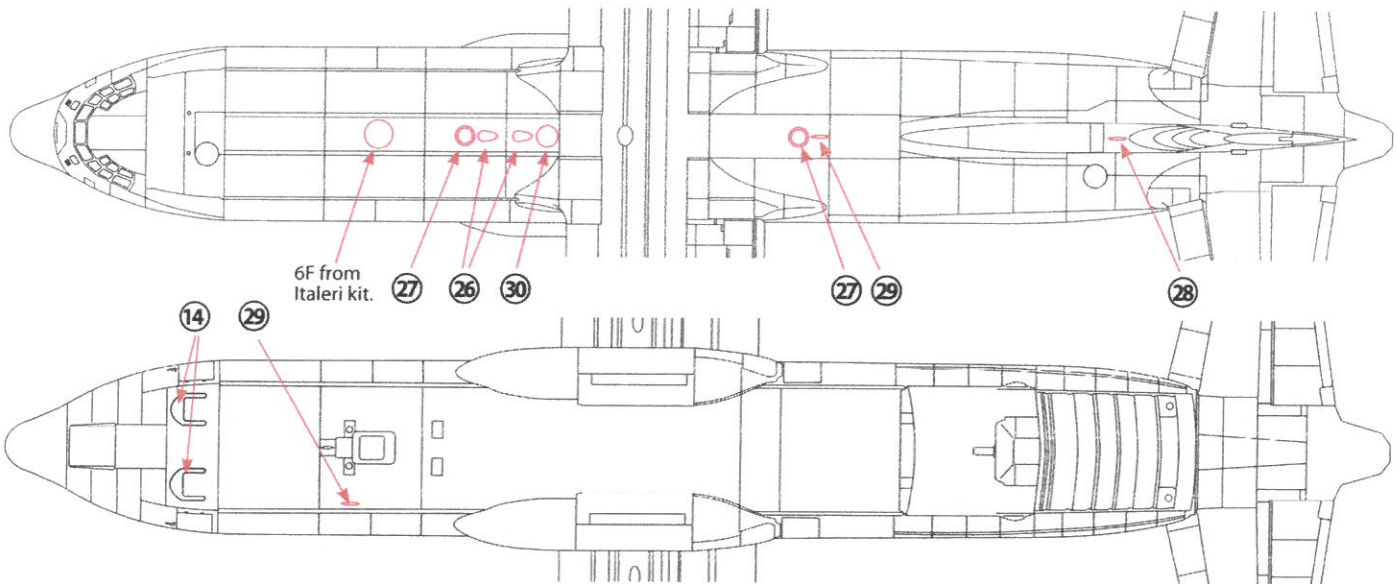

IAF - C-130J-30 Aerials location

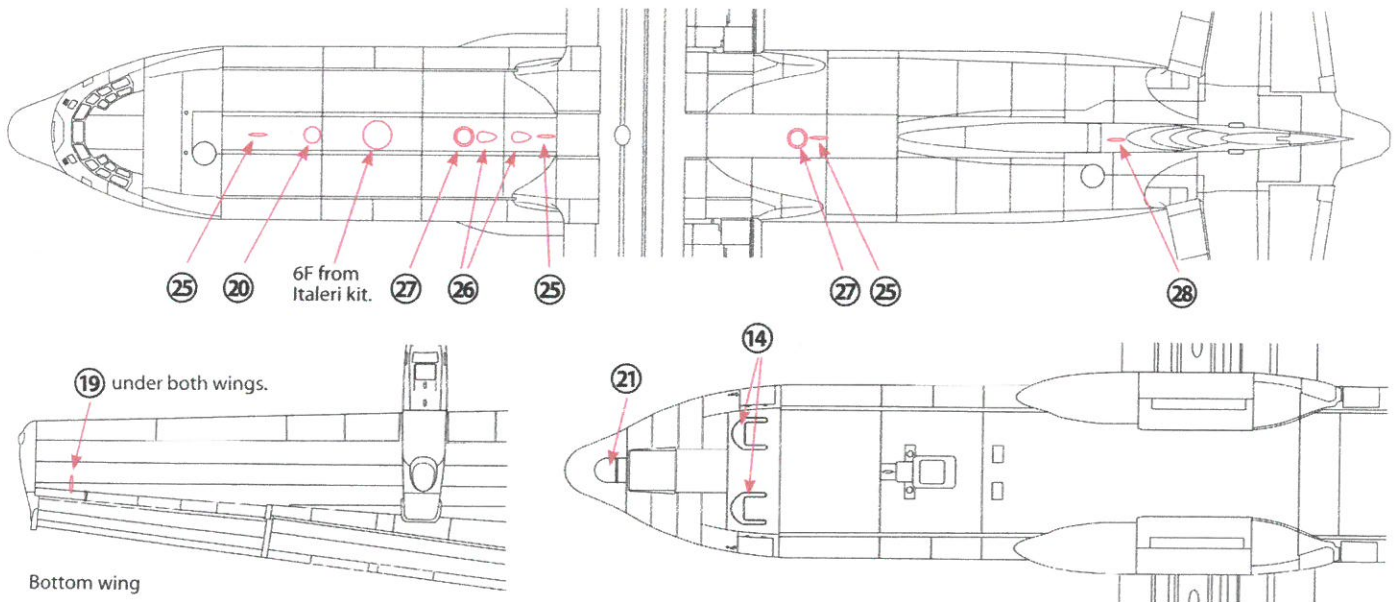

Bottom wing

Top View - Stencils and markings location

USAF markings

Upper left wing

Upper right wing

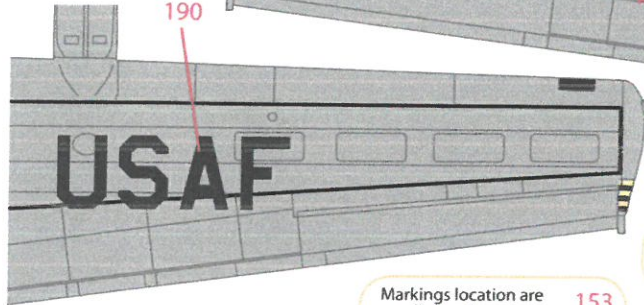

92

190

Trim decal 175 according to the USAF insignia location.

Markings location are parallel on the other wing - not mirror

153
148

Markings location are parallel on the other wing - not mirror

139 (138)
91 (94)

167
90

166
172

167
90

166
172

87
164
164

164
164

184
164

164
164

164
164

164
164

164
164

164
164

164
164

164
164

164
164

164
164

164
164

164
164

164
164

164
164

164
164

164
164

164
164

164
164

164
164

164
164

164
164

164
164

164
164

164
164

50
161
51
175

139 (138)
91 (94)

123 only this side
98

166
172

174
171

171
171

123
98

166
172

179
179

166
172

165
189

95
95

123
98

164
164

181
181

164
164

159
159

164
164

133
133

110
110

163
163

173
173

164
164

144
144

164
164

140
140

IAF insignia

Upper left wing

9 on left wing only

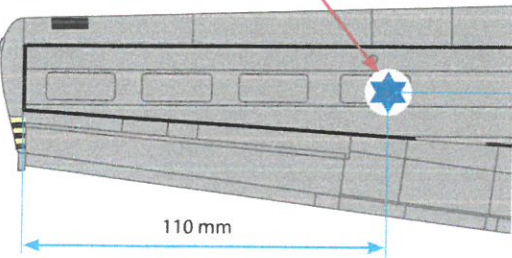

12.5 mm

110 mm

IAF tail number

661: - 196
662: - 2
665: - 1

10

131

110

164

160

164

153

148

164

164

164

164

164

164

164

164

164

164

164

164

164

164

164

164

164

164

164

164

164

164

USAF markings

IAF markings

USAF and IAF markings

FS 36173



Note:

All stencils are symmetric to the left wing.
Put decals at symmetric location unless mentioned differently.
Mirror markings are numbered in brackets.

Bottom View - Stencils and markings location

USAF Markings

Lower right wing

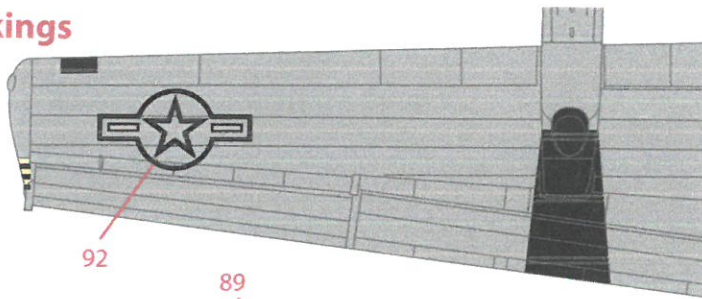

Lower left wing

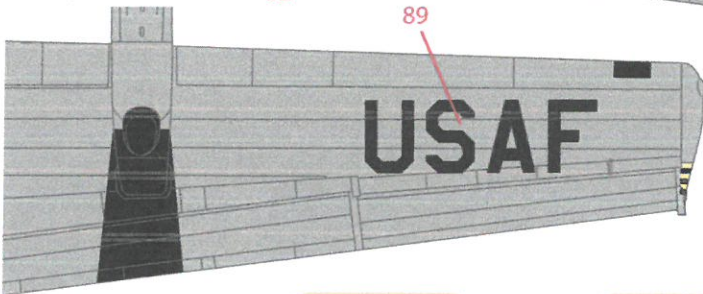

177

176

Markings location are parallel on the other wing - not mirror

Markings location are parallel on the other wing - not mirror

67 115
134 149

67 115
134 149

114

87

50

68

145
55

73
74

78

69

22 mm

77

73
74

54

70 (71)

22 mm

75 (76)

Matt black

Matt black

IAF insignia

Lower right wing

9
on right wing only

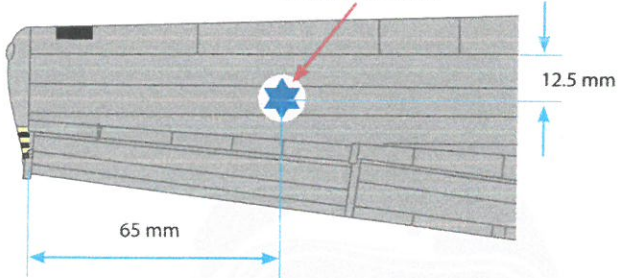

USAF markings

IAF markings

USAF and IAF markings

FS 36173



Note:

All stencils are symmetric to the left wing.
Put decals at symmetric location unless mentioned differently.
Mirror markings are numbered in brackets.

63

145
55

118

127

Right View - Stencils and markings location

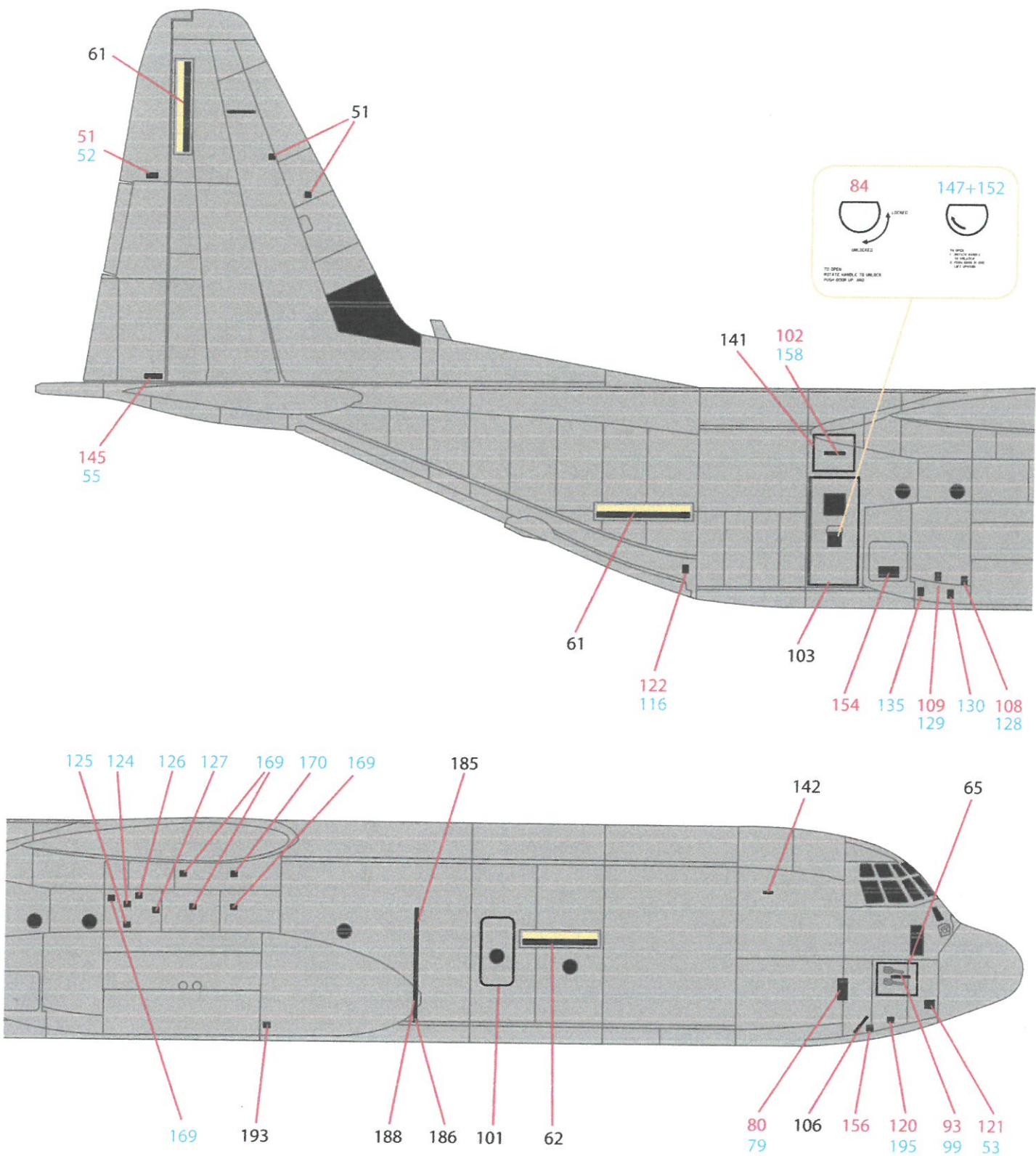

Left View - Stencils and markings location

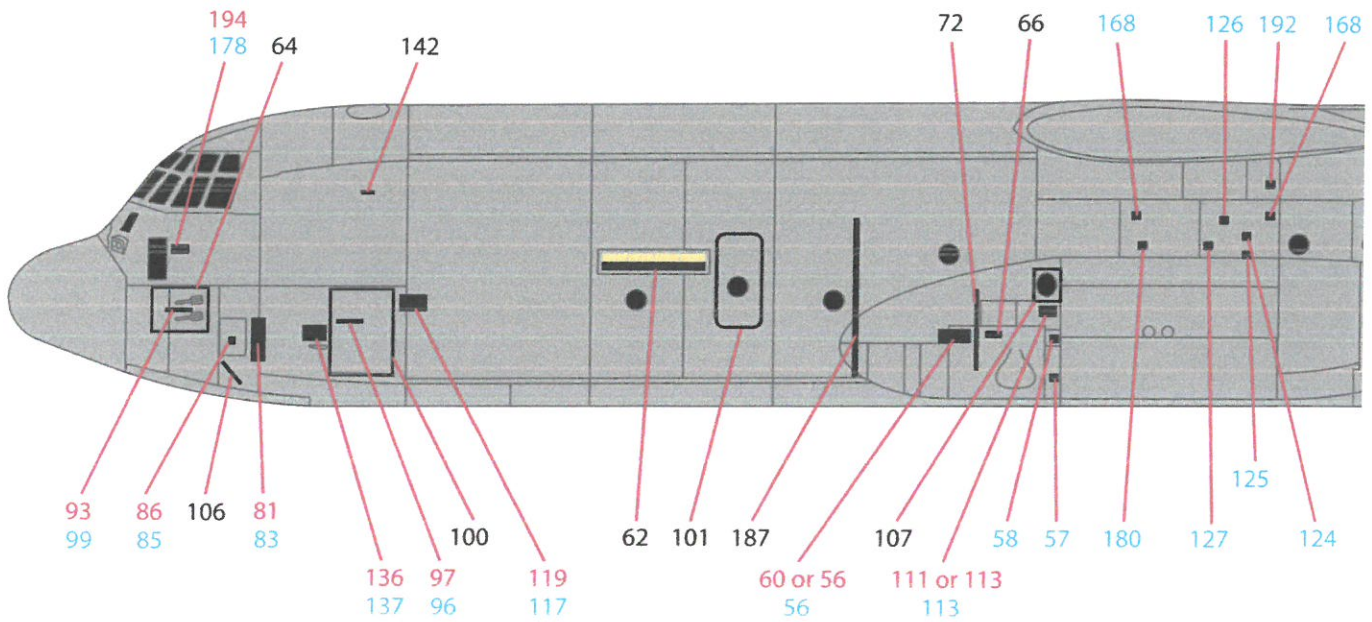
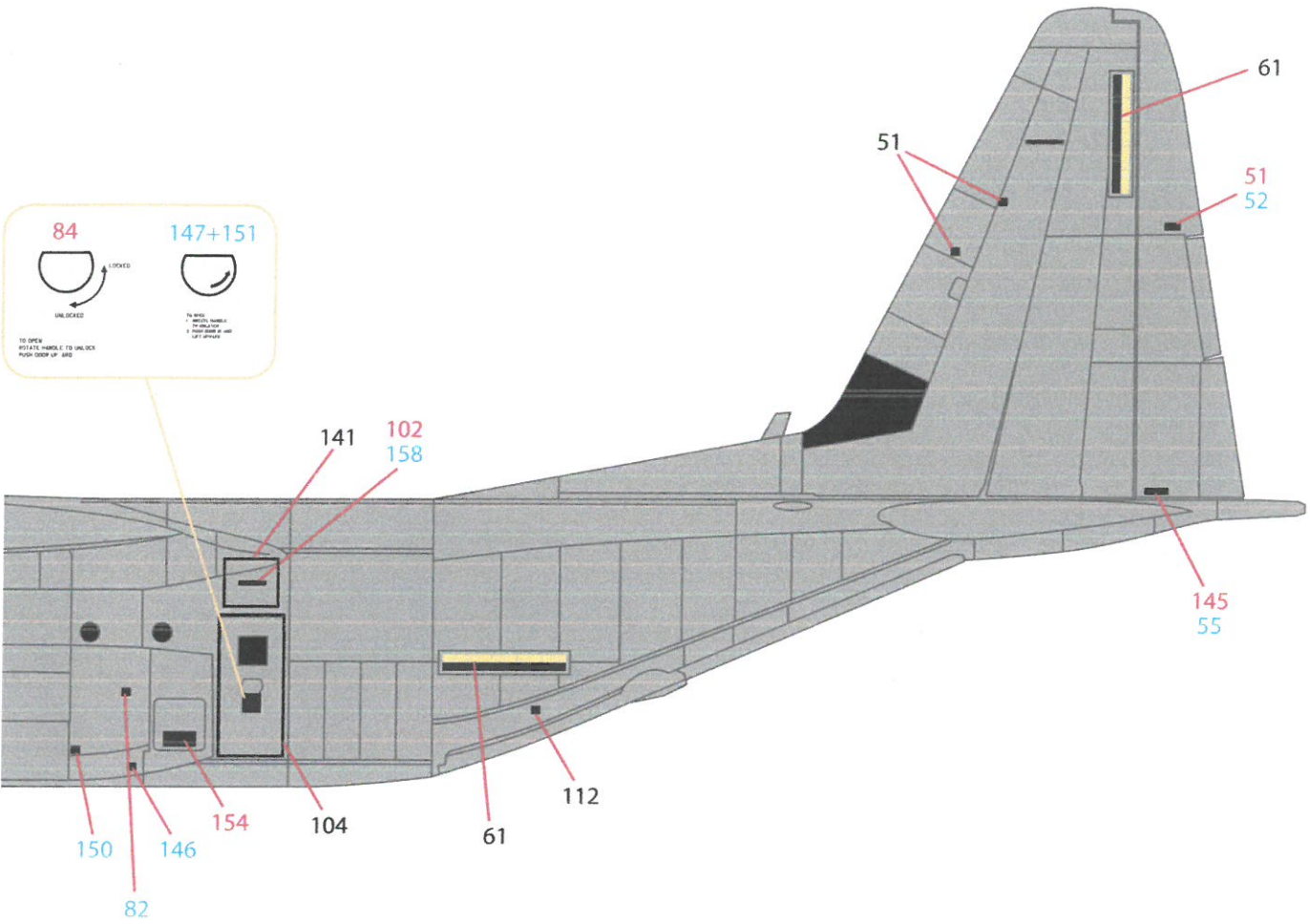

Note:

All markings appear on the right side as well, unless mentioned differently. Mirror markings are numbered in brackets.

C-130J-30, USAF #91431, 14rd Airlift Squadron, Rhode Island ANG, Quonset State Airport, Rhode Island, USA.

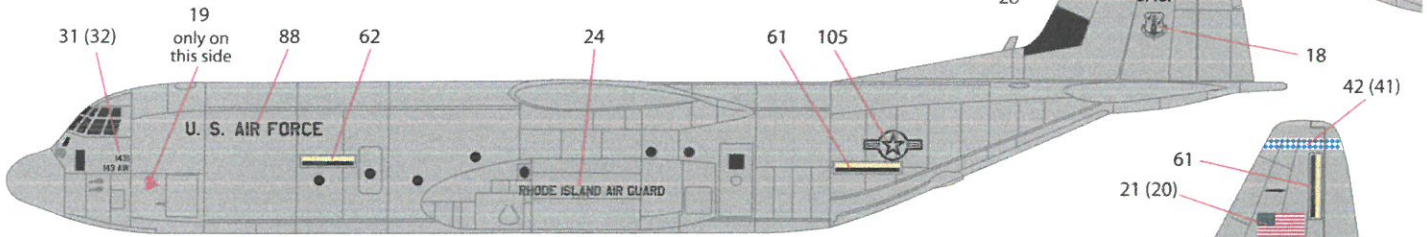

C-130J-30, USAFE #43142, 37th Airlift Squadron - Ramstein Air Base, Germany

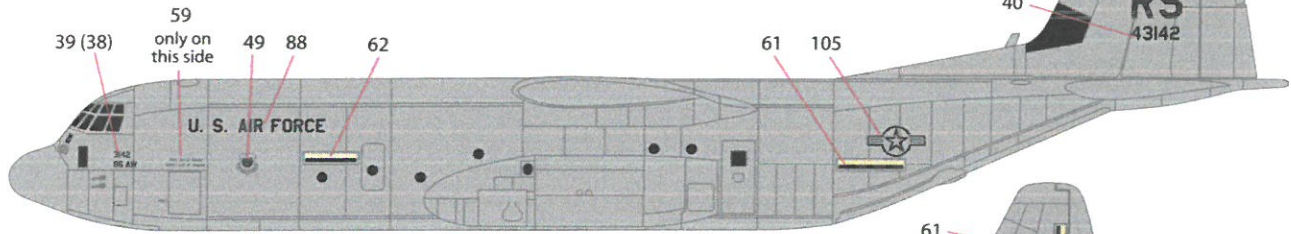

C-130J-30, USAF #76311, 41st Airlift Squadron - Little Rock AFB, Arkansas, USA

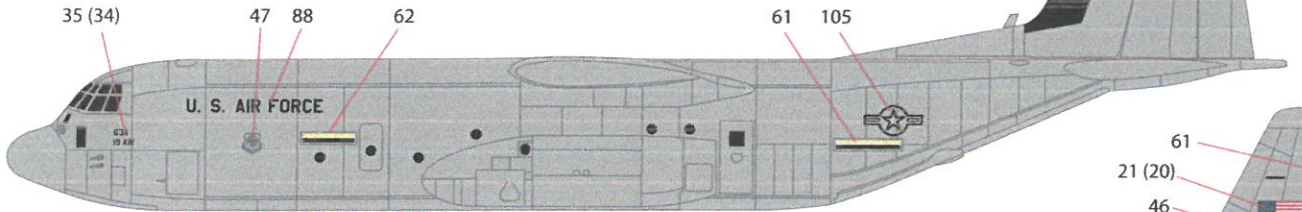

C-130J-30, USAF #83177, 317th Air Group, 39th Airlift Squadron - Dyess AFB, Texas, USA

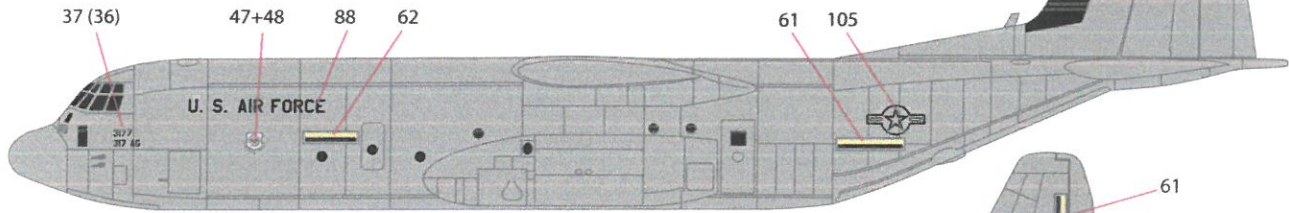

C-130J-30, USAF #51466, 115th Airlift Squadron - Port Hueneme ANG Station, California, USA

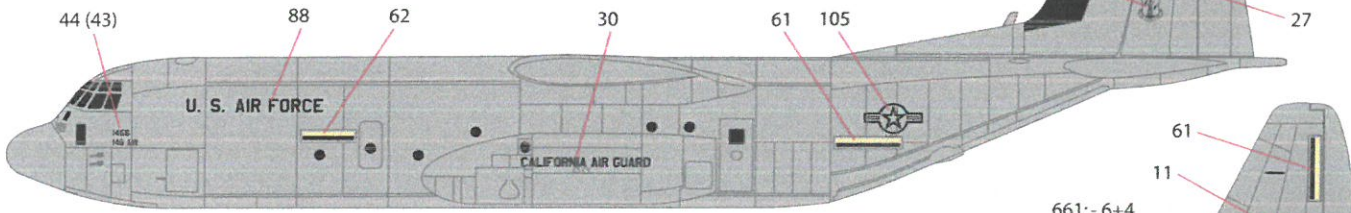

C-130J-30, IAF #661 or #662 or #665 "Samson", 103 squadron, Nevatim AFB, Israel

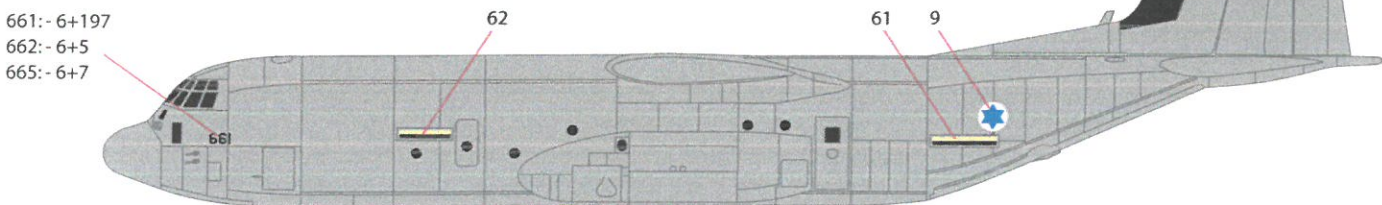



66 66 99887755332211
Tail number Nose number

66 7799883311
66 5522
Refueling hatch numbers

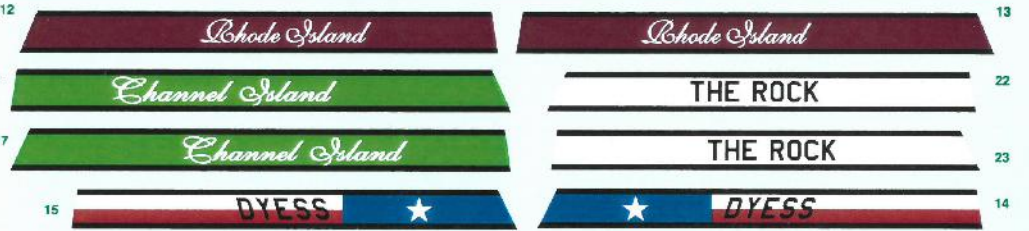

746311 83177
746311 83177

43142 40 43142 ANG CALIFORNIA AIR GUARD RHODE ISLAND AIR GUARD
51466 91431 ANG CALIFORNIA AIR GUARD RHODE ISLAND AIR GUARD
51466 91431 43 1466 1466 44 31 1431 1431 32 34 6311 6311 35 36 3177 3177 37 38 3142 3142 39
146 AW 146 AW 143 AW 143 AW 19 AG 19 AG 317 AG 317 AG 86 AW 86 AW

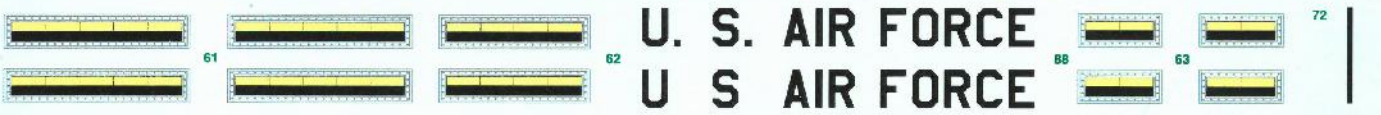

USAF USAF

