

1:35 '39-'45 SERIES

# StuG.III Ausf.G May 1943 Production mit Schürzen

Smart  
Kit



DRAGON

Project supervised by HIROHISA TAKADA.

Technical drawings provided by MINORU IGARASHI and the DRAGON Engineer Team.

Thanks to TOM COCLKLE and GARY EDMUNDSON as Technical Consultants.

KIT NO. 6578

Ax2

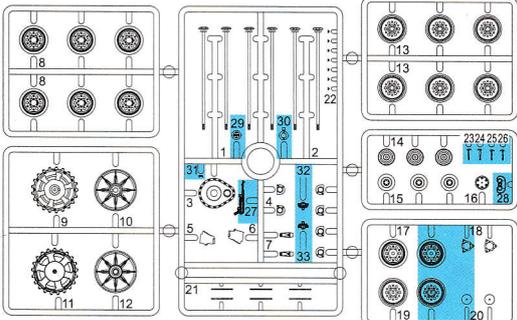

B

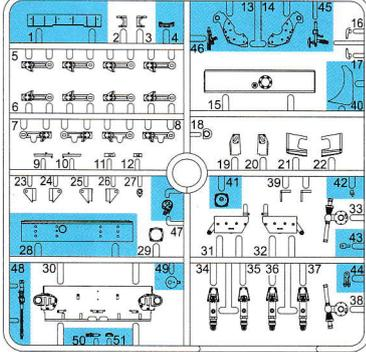

D

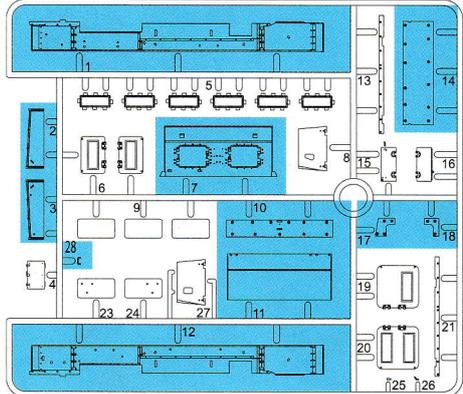

C

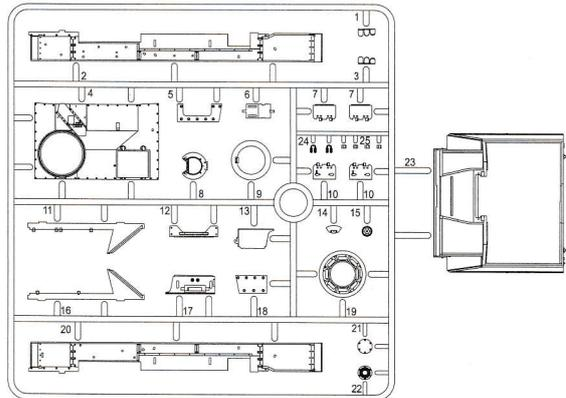

E

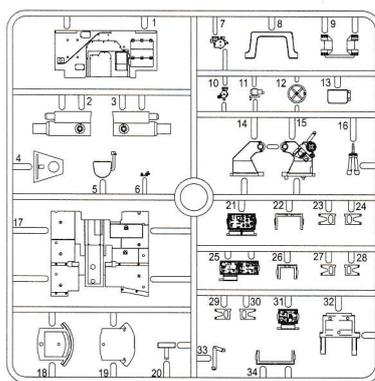

L

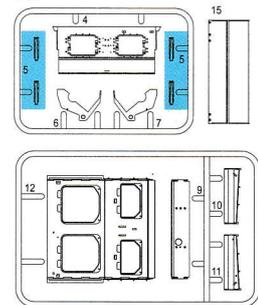

F

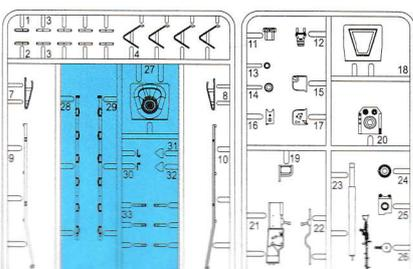

G

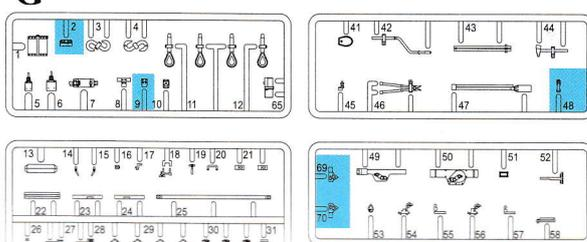

MA (Photo-etched Parts)

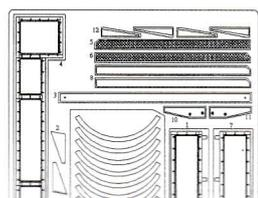

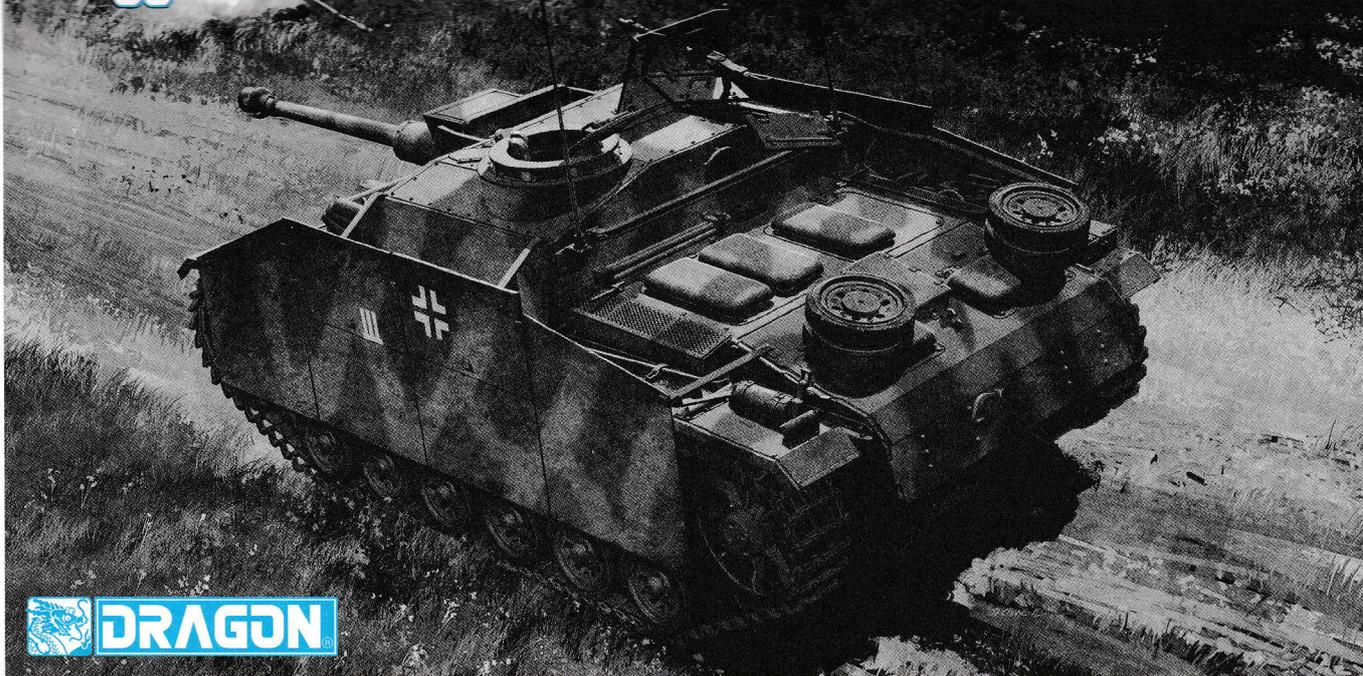

Project supervised by HIROHISA TAKADA.  
 Technical drawings provided by MINORU IGARASHI and the DRAGON Engineer Team.  
 Thanks to TOM COCKLE and GARY EDMUNDSON as Technical Consultants.

KIT NO. 6578

**Ax2**

**B**

**D**

**C**

**E**

**L**

**F**

**G**

**J**

**H**

**Z** (Metal Tow Cable) (340mm)

**MA** (Photo-etched Parts)

**MBx2** (Metal Parts)

の部品は使用しません  
 Parts not for use.  
 Telle werden nicht verwendet.  
 Pieces a ne pas utiliser.  
 Parti nin ulizzati.  
 不需要使用的部件

**x2**  
2つ製作してください  
MAKE 2PCS  
2 TEILE FERTIGEN  
EFFECTUER 2 PIECES  
FAIRE DEUX PEZZI  
TEE 2 KPL  
GOR 2 ST  
製作二組

**!**  
切り取ってください  
REMOVE  
ENTFERNEN  
RETIRES  
SEPARARE  
POISTA  
AVLAGSNA  
切取

**\***  
接着しないでください  
DO NOT CEMENT  
NICHT KLEBEN  
NE PAS COLLER  
NON INCOLLARE  
EI LIMAA  
LIMMAEJ  
不用黏合

**\***  
デカールを貼ってください  
APPLY DECAL  
HIER ABZIEHBLD  
APPLIQUER DECALCOMANIE  
ASETA SIIRTOKUVÄ  
APPLICIERE DECALEN  
貼上水贴纸

**!**  
穴を埋めてください  
FILL HOLE  
SCHLIESSEN  
BOUCHER LE TROU  
FORD PIENO  
TAYTÄ REIKA  
FYLL Hålet  
孔埋填平

**!**  
接着剤が乾くまで2-3分待ってください  
PLEASE WAIT FOR A FEW MINUTES UNTIL DRY  
ENKE MINUTER VÄNTA SÖCH KLÄRER OFF BERÖRNINGST  
ASPETTARE ALGUN MINUT FINDE LA COLLA SI KOSIQUA  
VEILLES WÄRTEN QUELQUES JOURS QUEZHE  
VÄNTA NÅGRA MINUTER FÖLLS TOR  
ODOR MUKANA MUKUTUKES KUNNUT  
稍候數分鐘 直至接著劑乾固

**!**  
注意してください  
BE CAREFUL  
HIER VORSICHT  
FAIRE ATTENTION  
USARE ATTENZIONE  
VAROVIŠTI  
FORIKTIGT  
小心留意

**!**  
穴を開けてください  
OPEN HOLE  
FAIRE UN TROU  
FORD APERTO  
AVAA REIKA  
OPPIVA HALET  
鑽孔

**!**  
接着してください  
CEMENT TOGETHER  
ZUSAMMENKLEBEN  
COLLER ENSEMBLE  
INCOLLARE INSIEME  
LIMAA YHTIEN  
LIMMA IHOP  
用膠黏合

**!**  
折り曲げてください  
BEND  
BITTE BIEGEN  
PLIER S'IL VOUS PLAÏT  
PIEGARE  
TAITA  
BOCKA  
屈曲

**!**  
どちらか選択してください  
OPTIONAL  
NACH BELIEBEN  
FACULTATIF  
FACOLTATIVO  
VALINNANVARAINEN  
VALBAR  
可以選擇採用

**!**  
瞬間接着剤 (金属用)  
INSTANT GLUE FOR METAL  
METALLKLEBER  
COLLA A METAL INSTANTANEE  
FACULTATIVO  
COLLA Istantanea per METALLU  
PIKALIMAA METALLON VÄRTEN  
SNÄBLIM FÖR METALLDELAR  
金屬用速乾膠

**H1** GSI CREOS CORP. AQUEOUS HOBBY COLOUR **1** GSI CREOS CORP. MR. COLOUR  
MODEL MASTER COLOR

H12 2	ブラック	1747	BLACK	SCHWARZ	NOIR	NERO	黑色
H11 62	つや消しホワイト	1768	FLAT WHITE	MATTWEISS	BLANC MAT	BLANCO OPACO	啞白色
H12 33	つや消しブラック	1749	FLAT BLACK	MATTSCHWARZ	NOIR MAT	NERO OPACO	啞黑色
H18 28	黒鐵色	1415	STEEL	STAHL	ACIER	ACCIAIO	黒鐵色
H37 43	ウッドブラウン	1735	WOOD BROWN	HOLZBARAUN	BRUN BOIS	MARRONE LEGNO	木棕色
H76 61	焼鐵色	1406	BURNT IRON	GEBR, EISEN	FER BRULE	FERRO BRUCIATO	燒鐵色
H80 54	カーキグリーン	1710	KHAKI GREEN	KHAKIGRÜN	VERT KHAKI	VERDE KAKI	砵礮綠色
H403 1	ダークイエロー	2099	DARK YELLOW	DUNKEL GELB	JAUNÉ FONCÉ	GIALLO SCURO	暗黃色

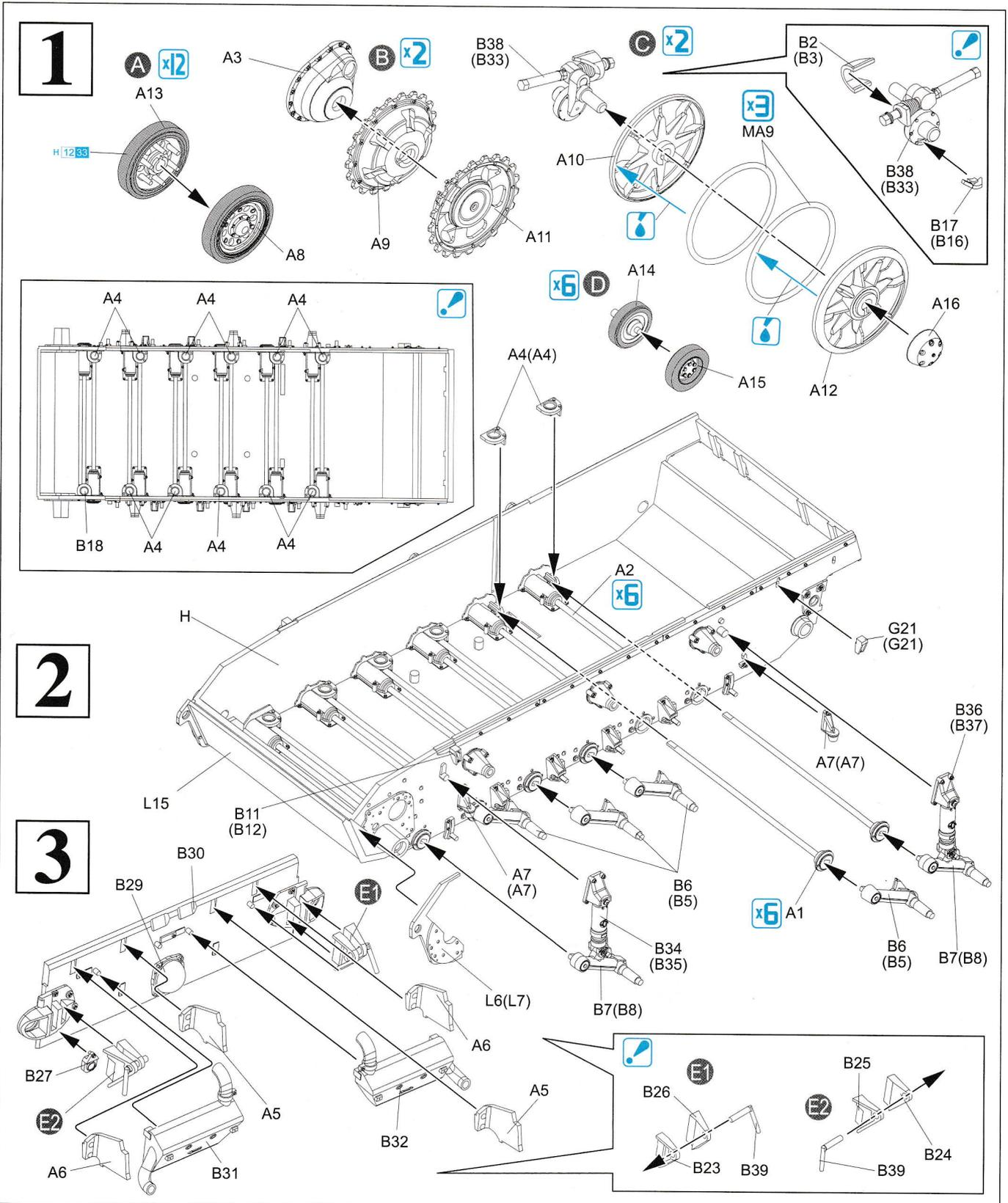

4

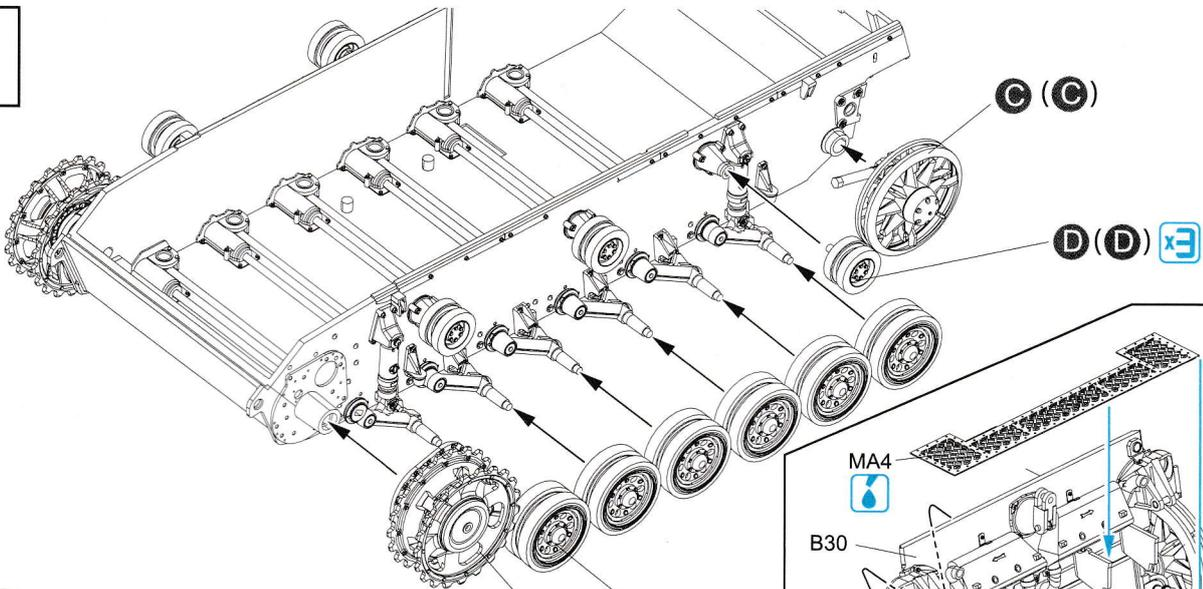

5

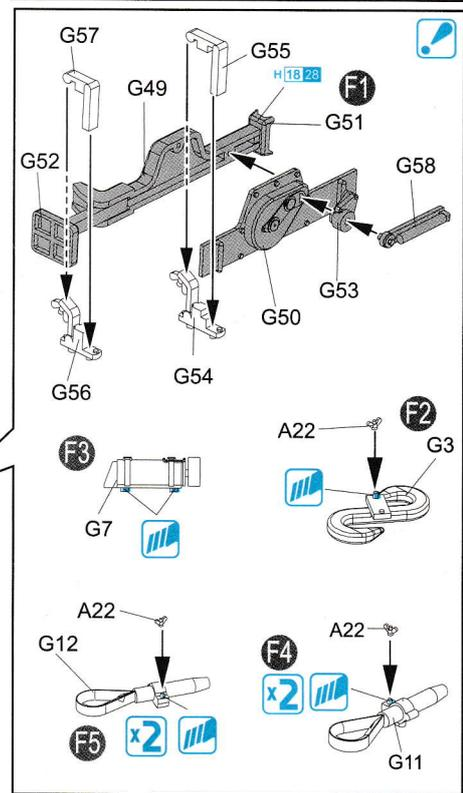
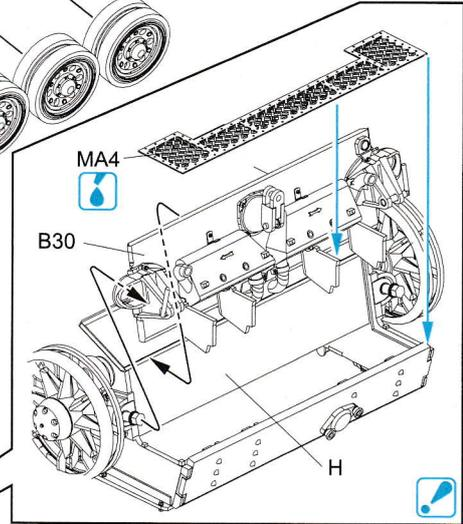
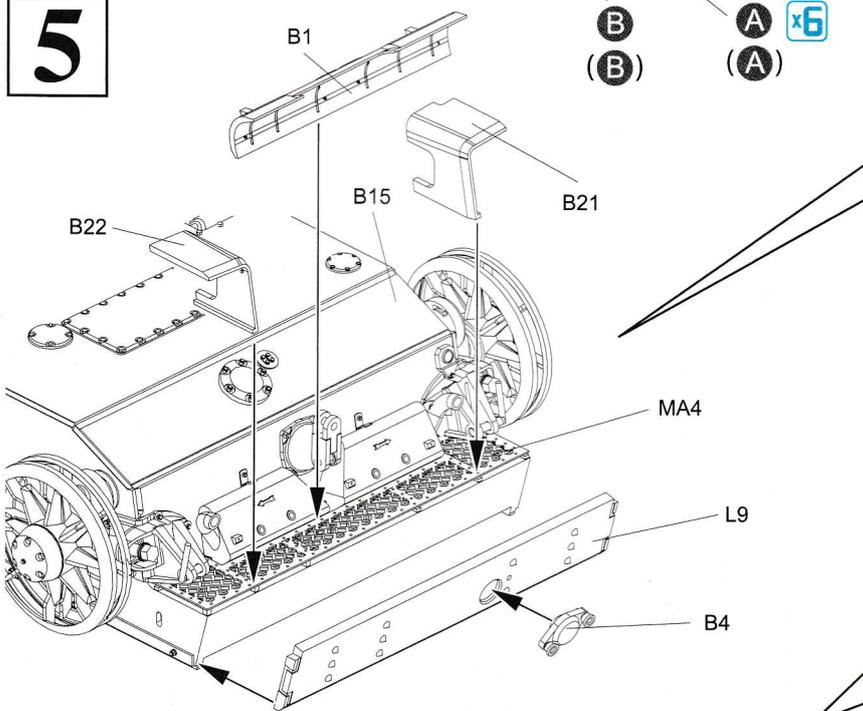

6

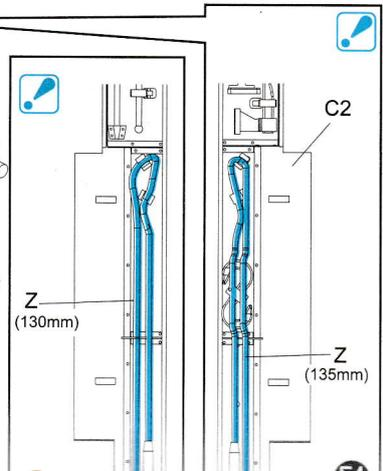
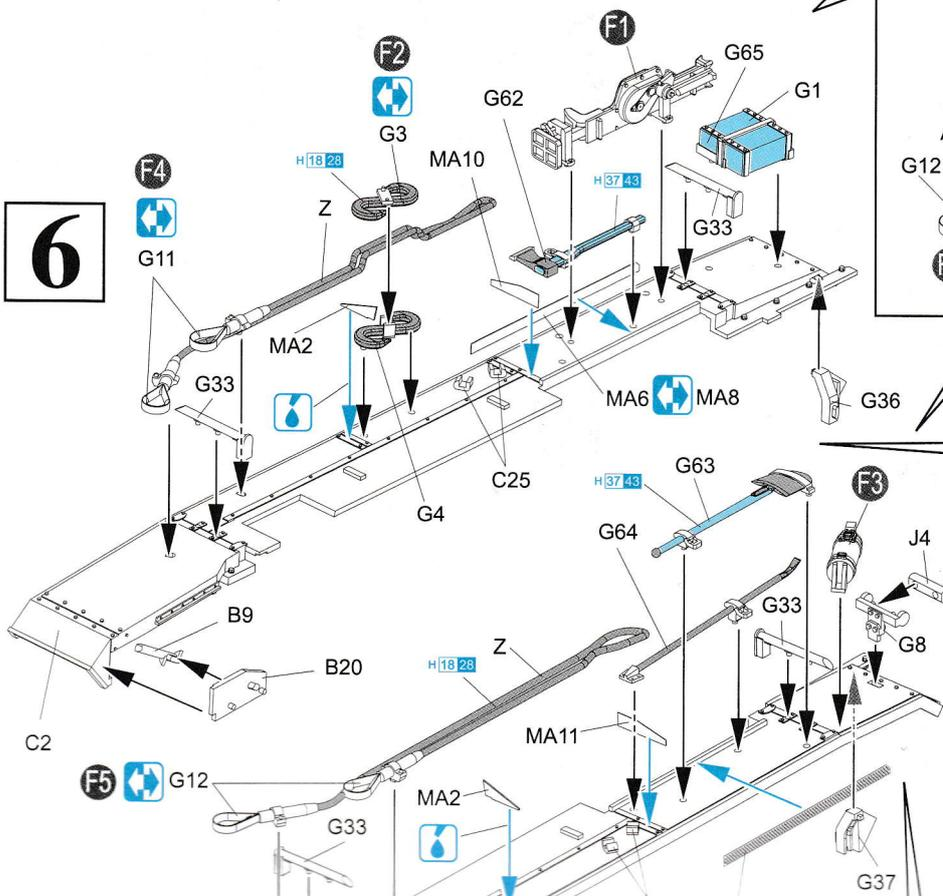

5

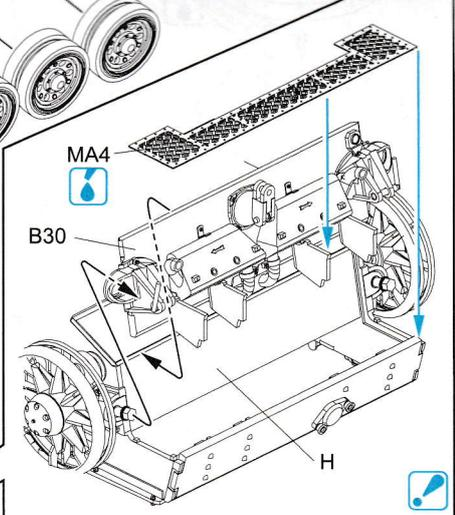
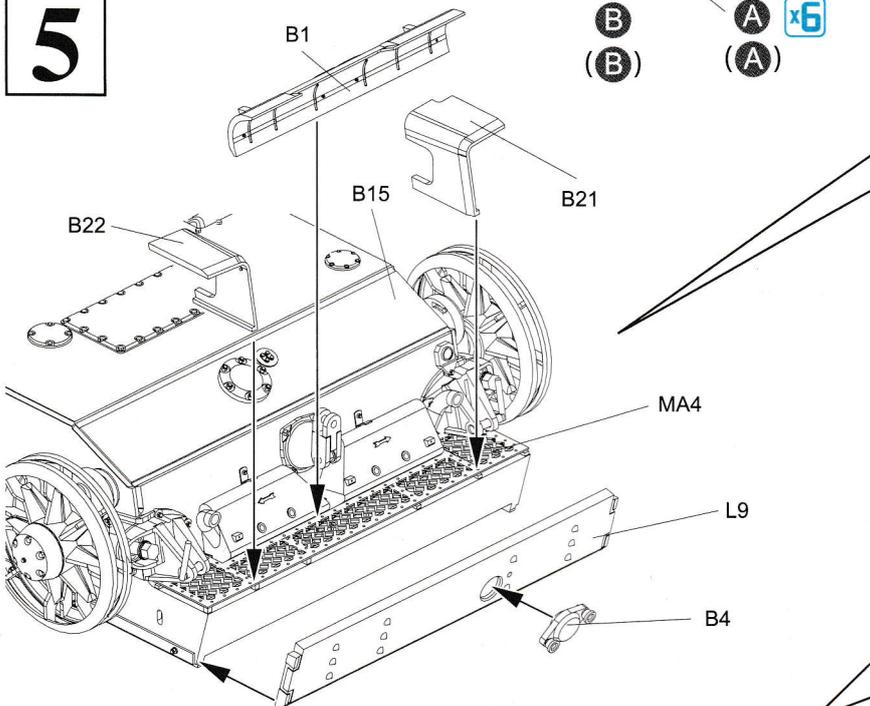

6

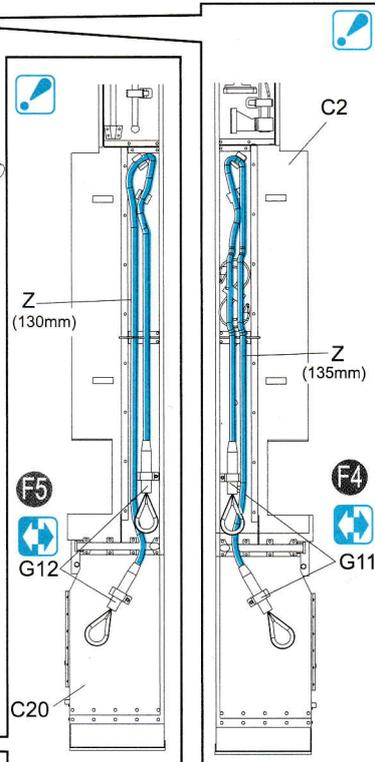
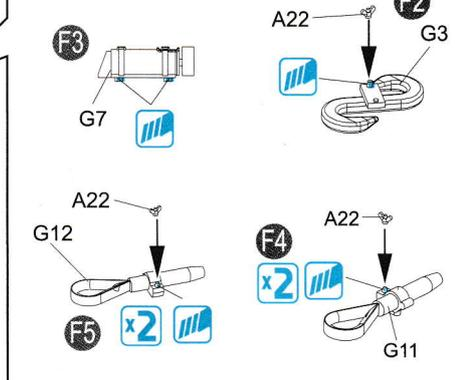
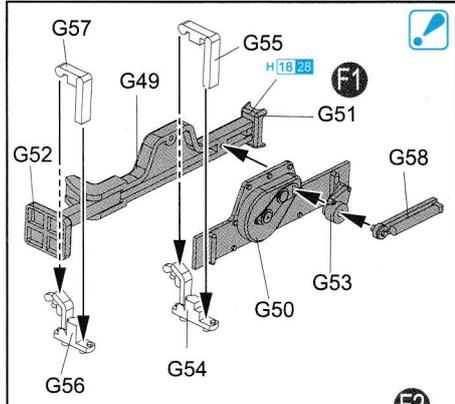
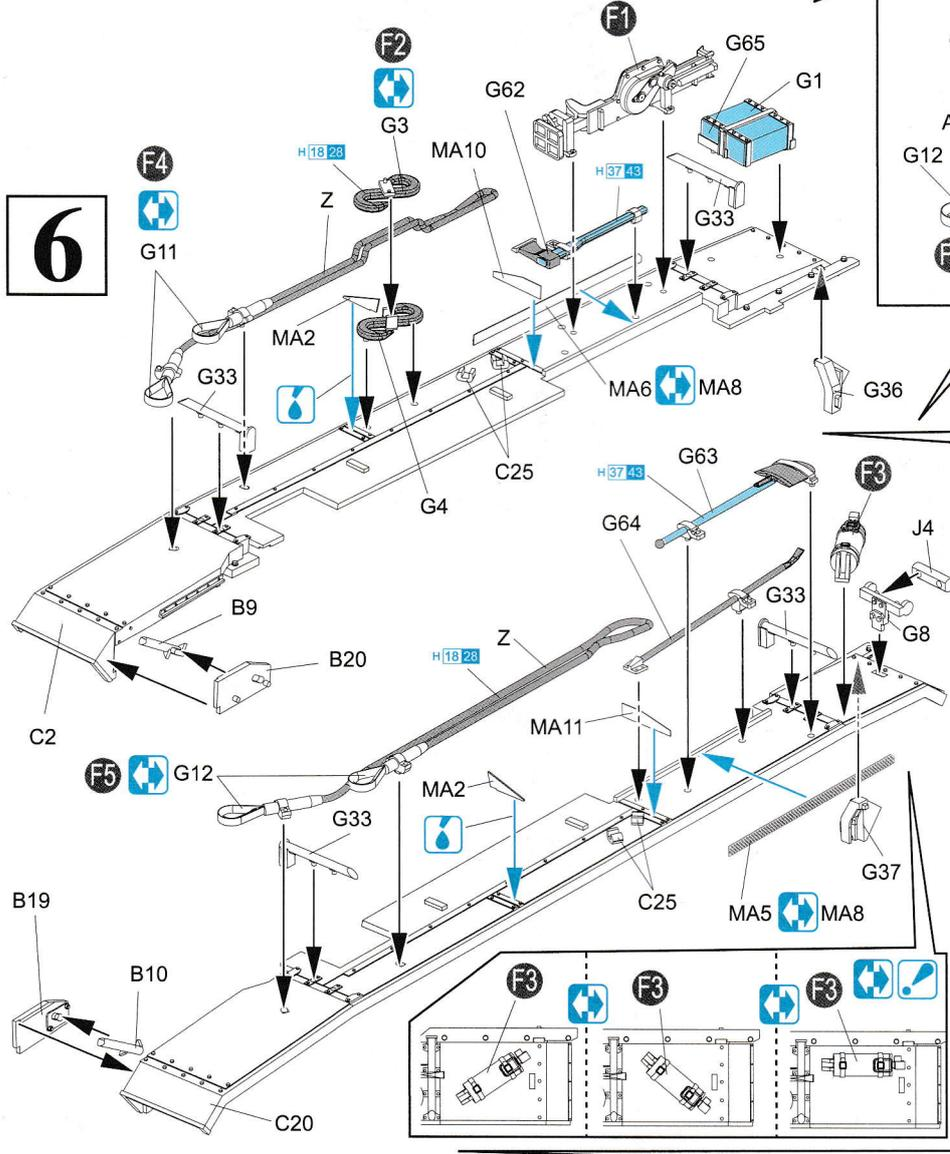

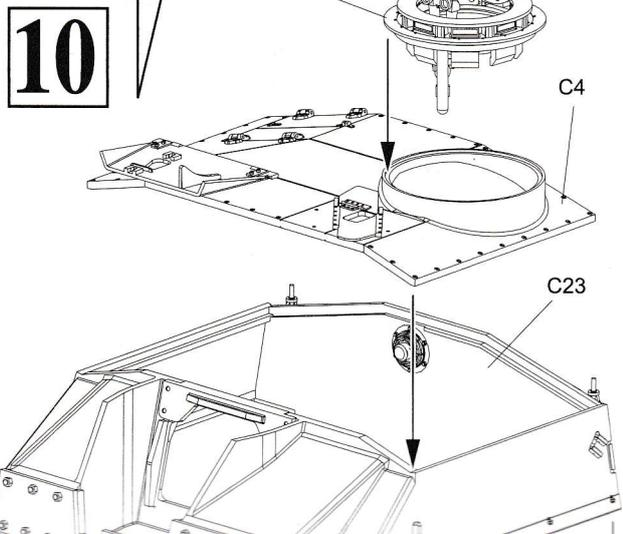
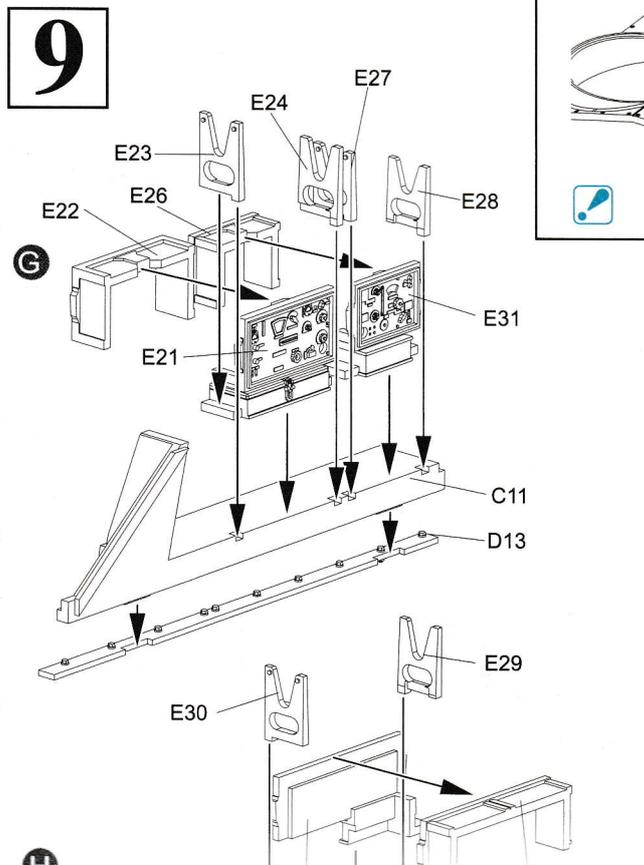
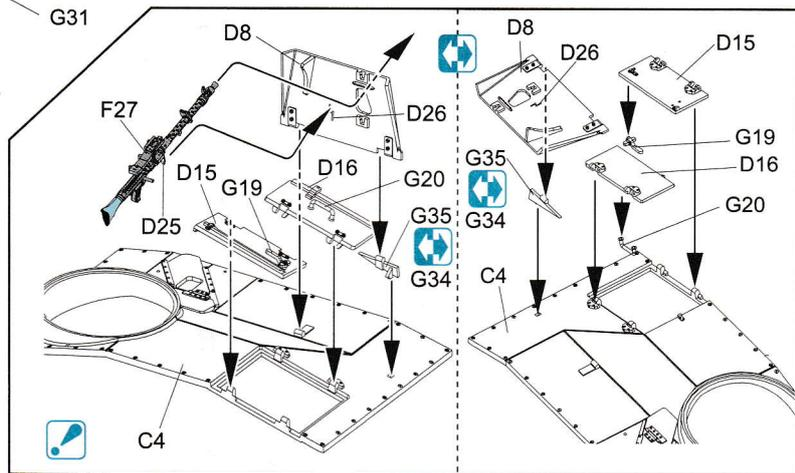
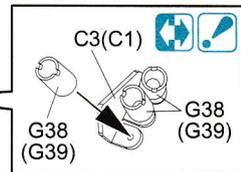
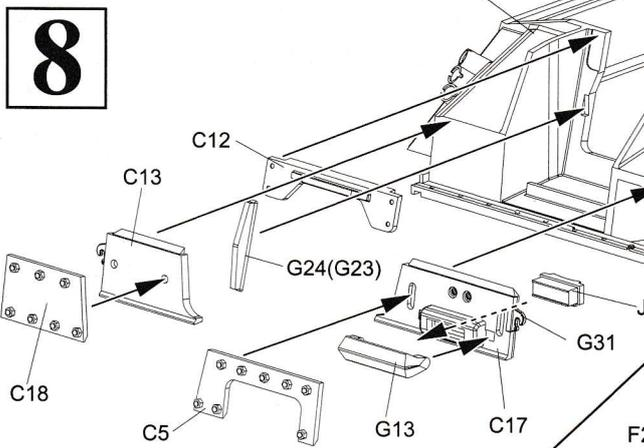
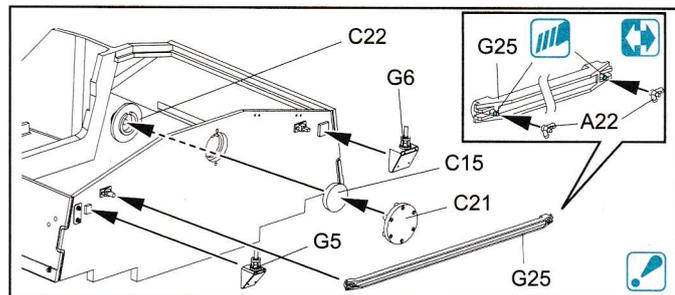
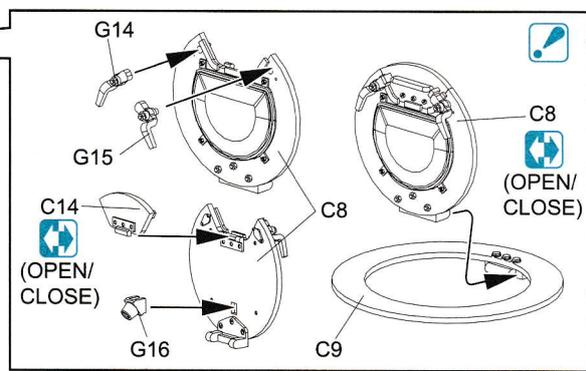
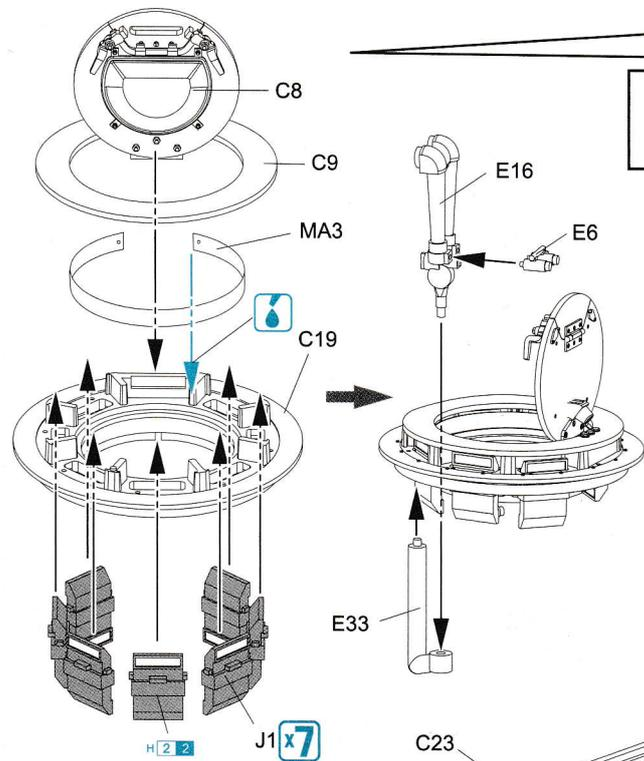

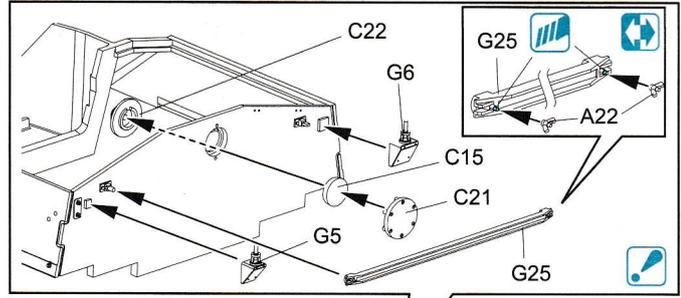
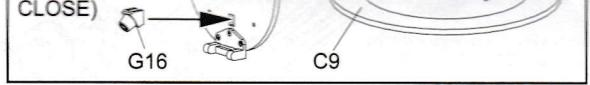
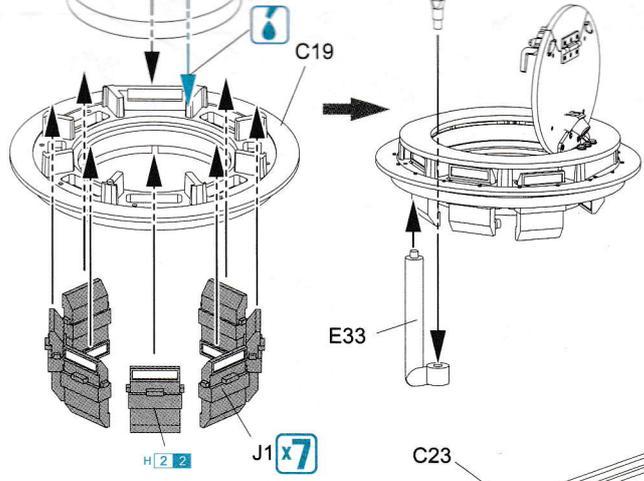

# 8

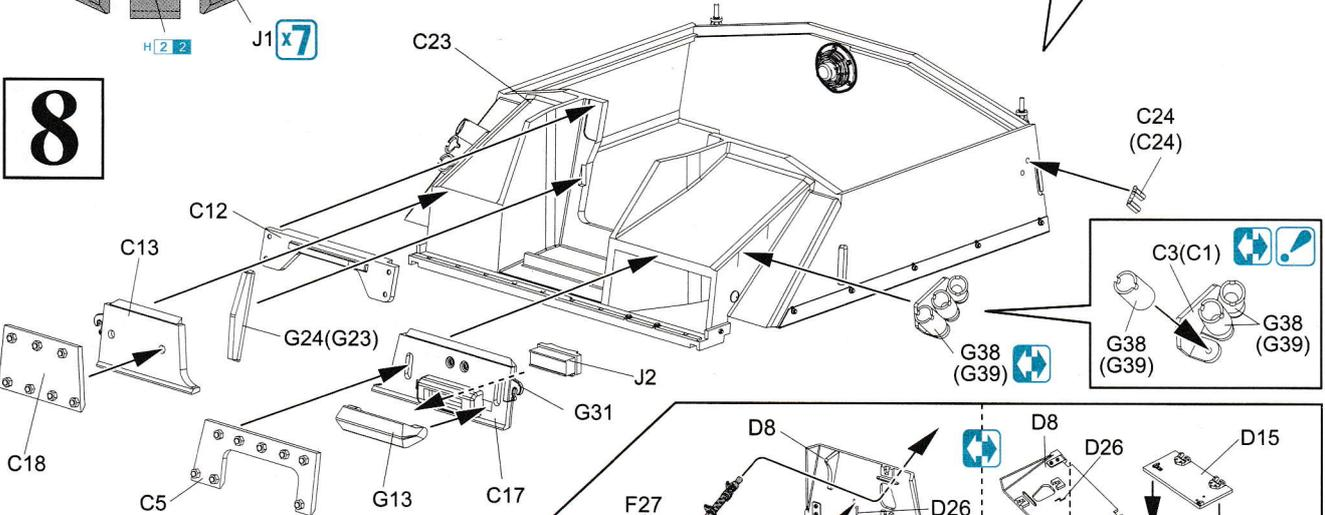

# 9

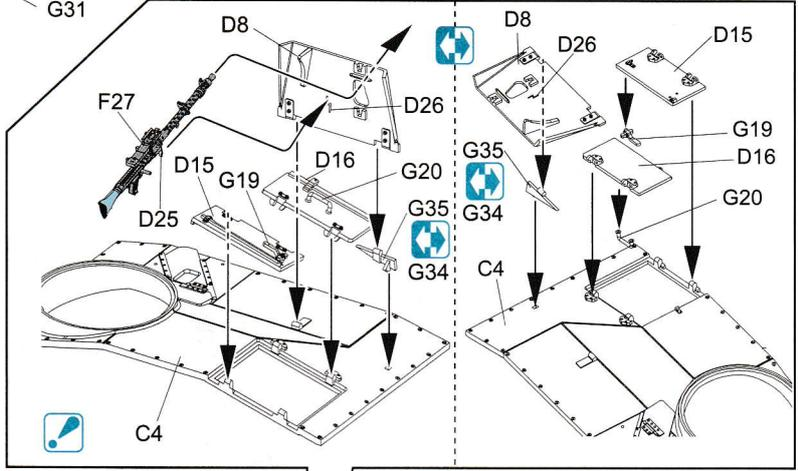
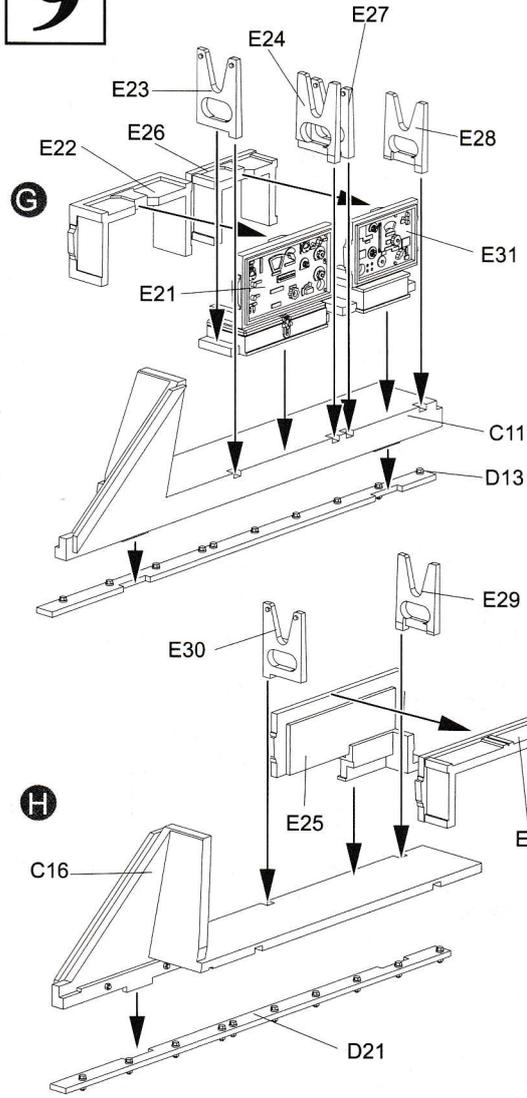

# 10

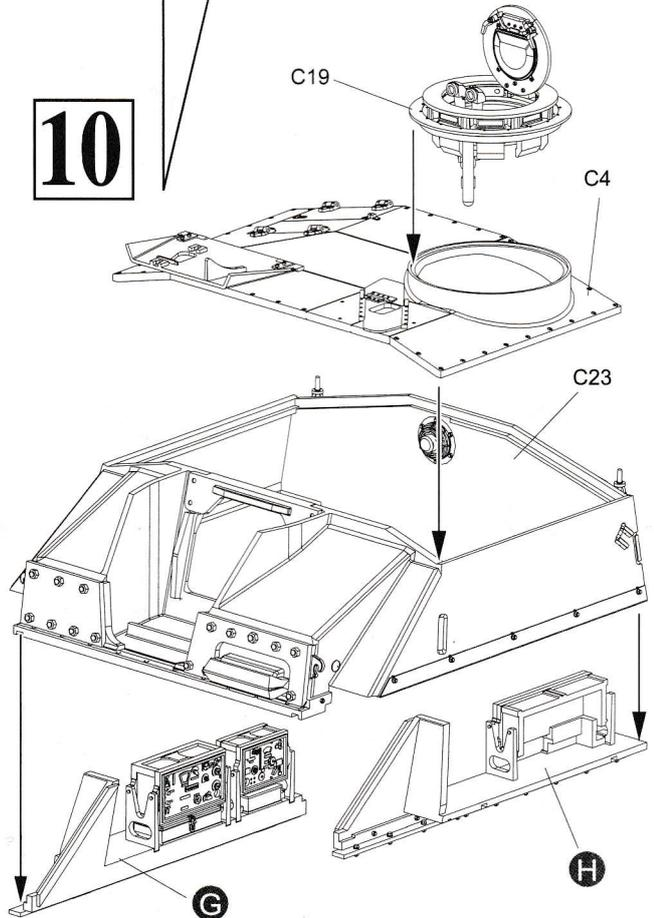





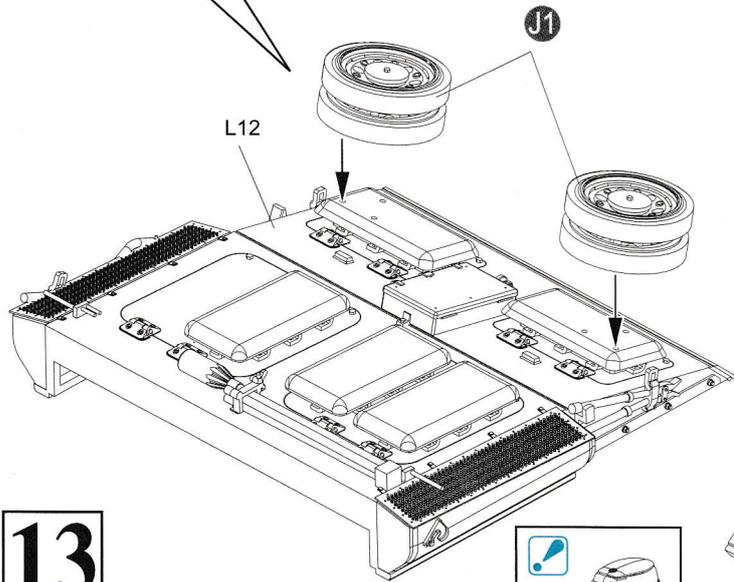
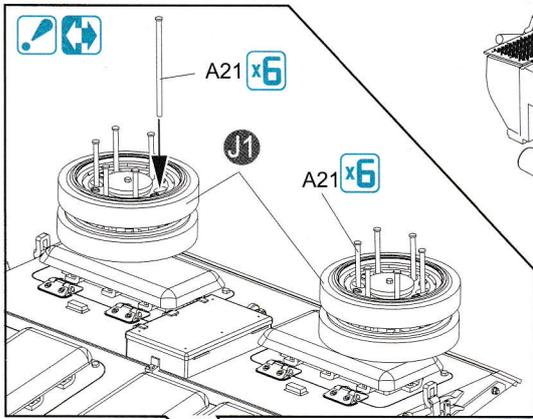
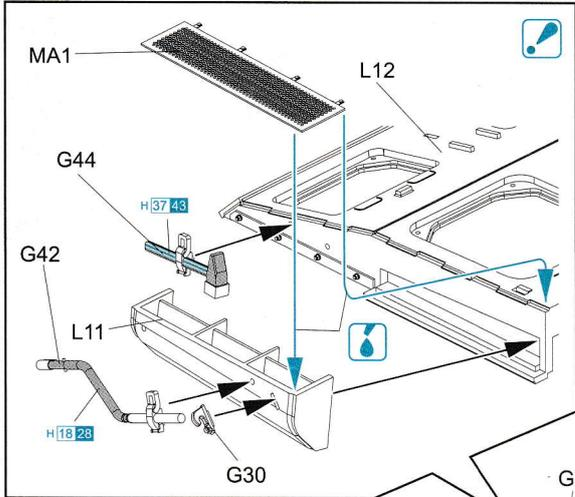
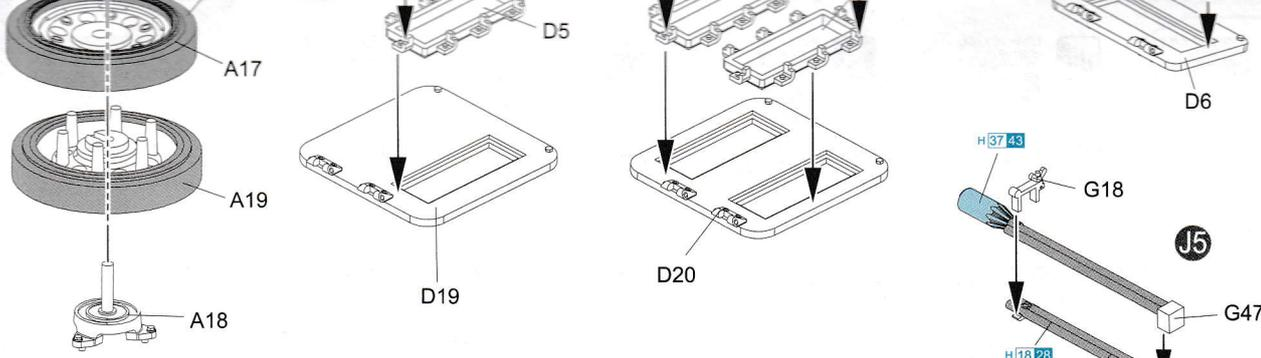

13

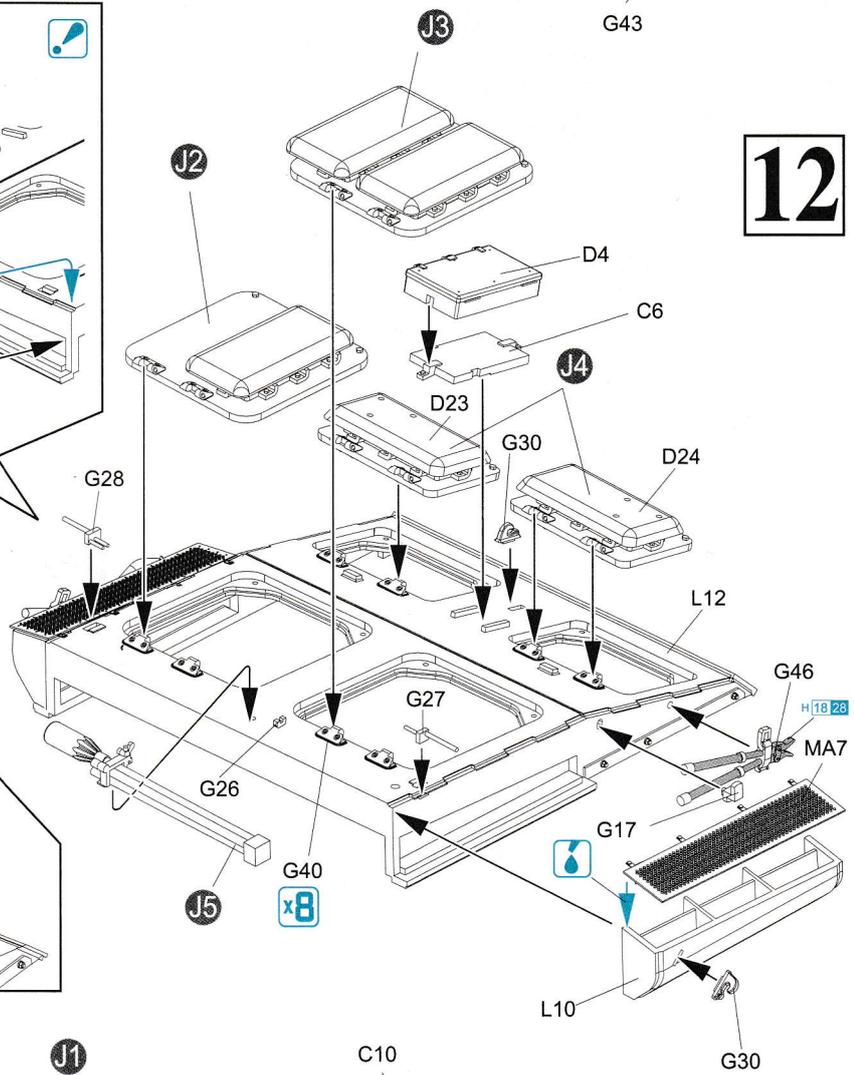
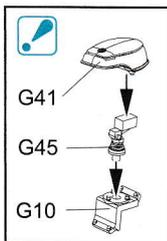

12

14



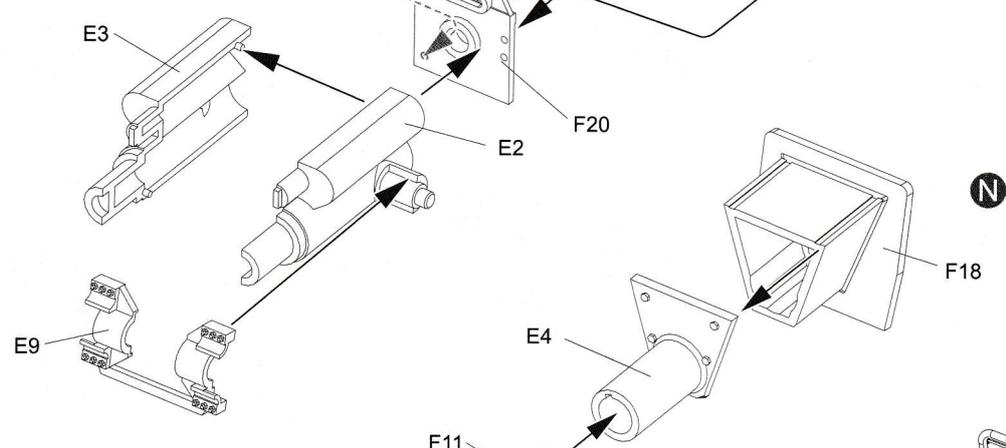
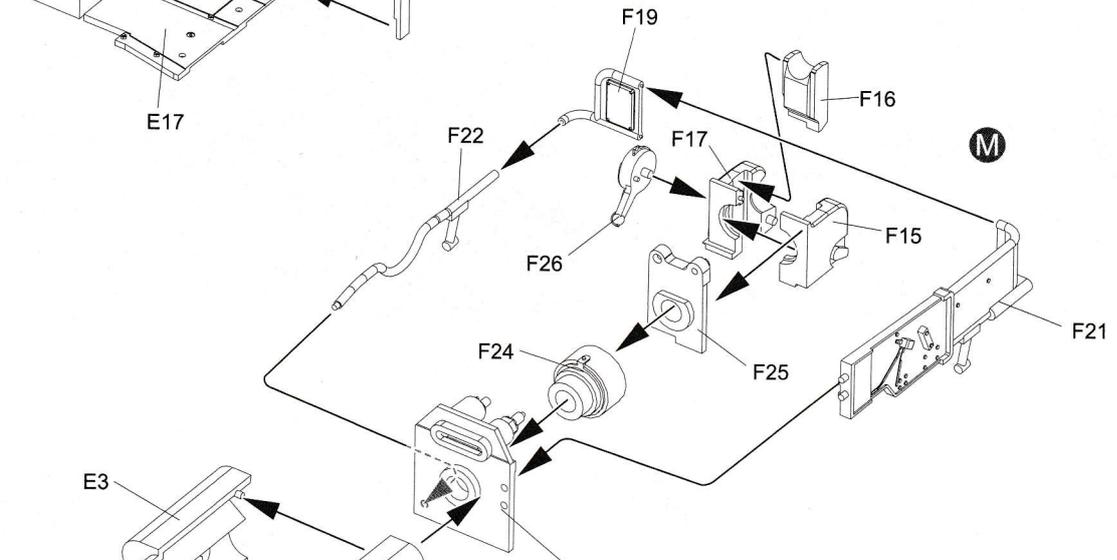
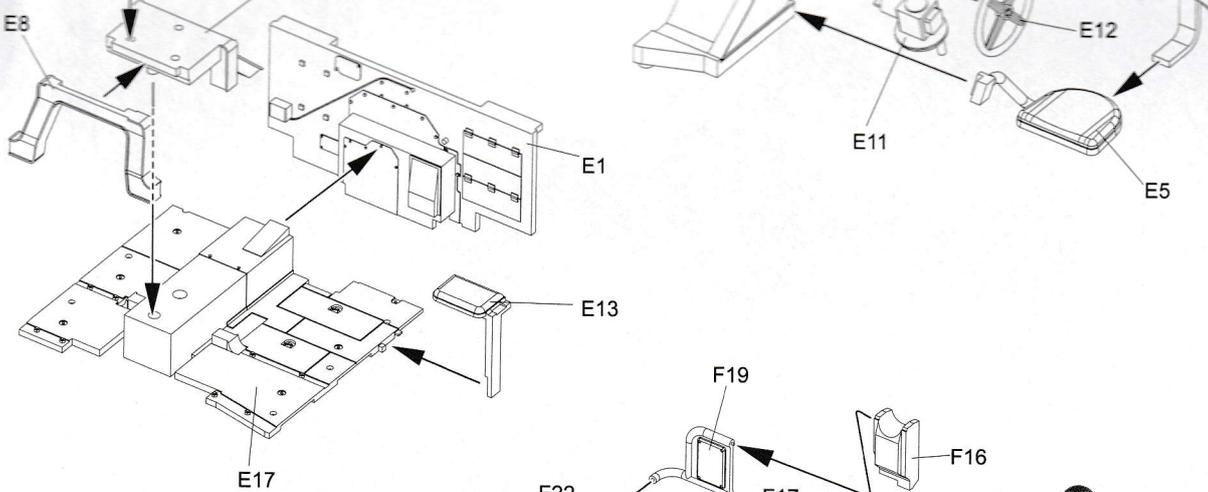

**16**

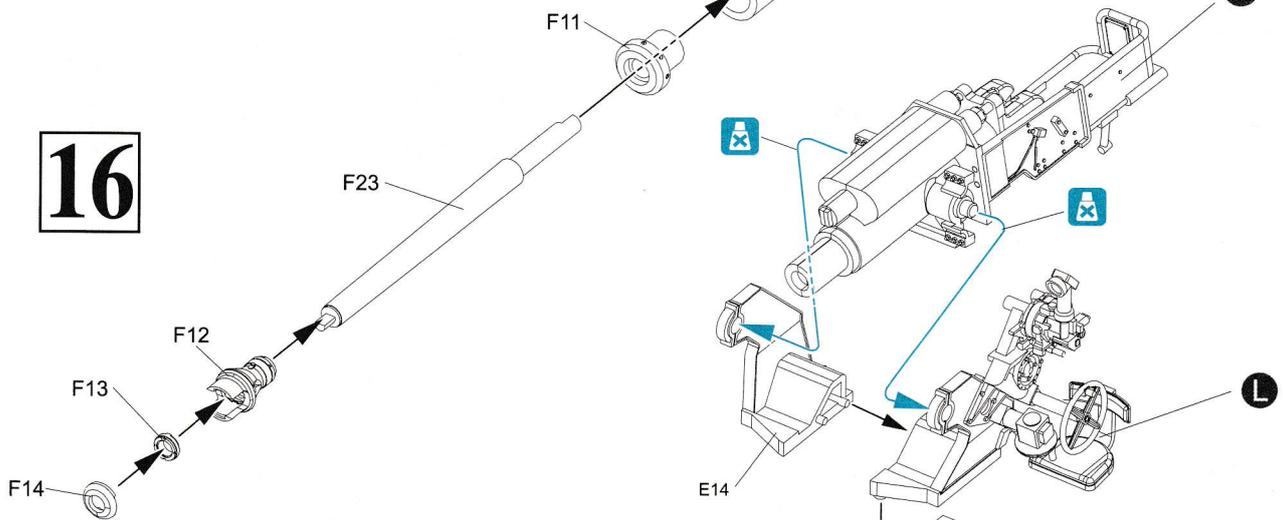

**17**

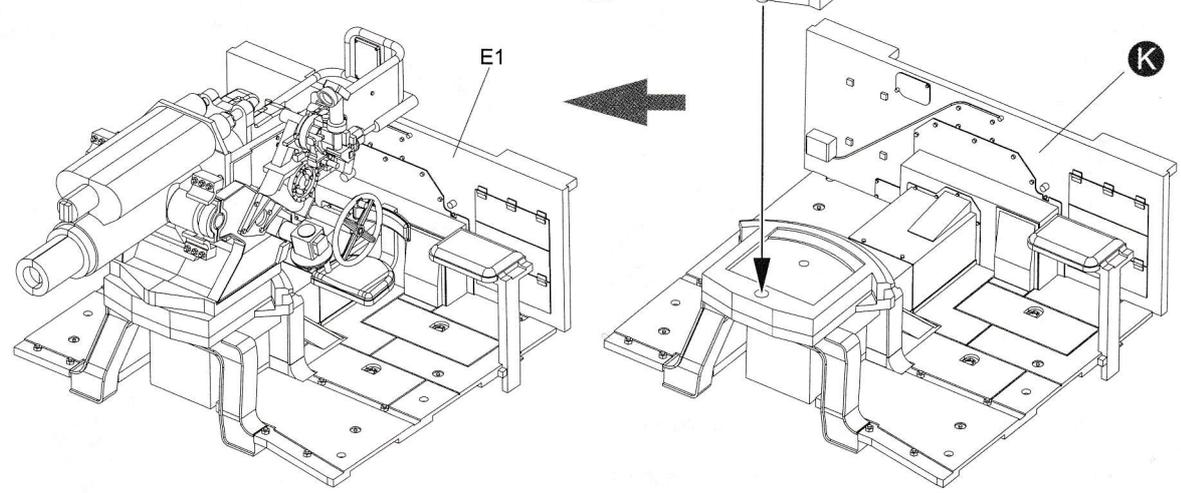

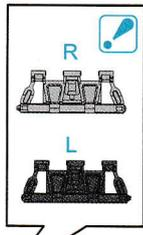
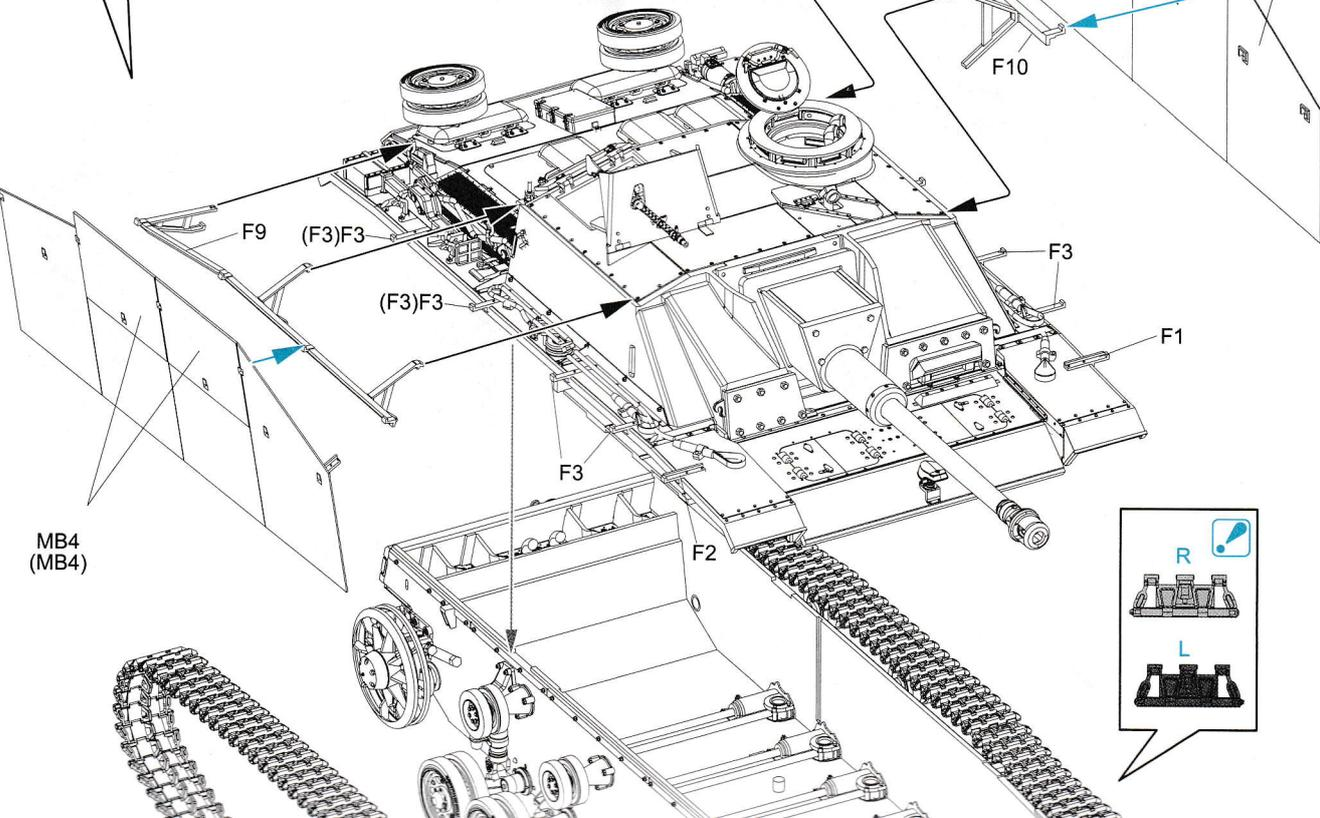
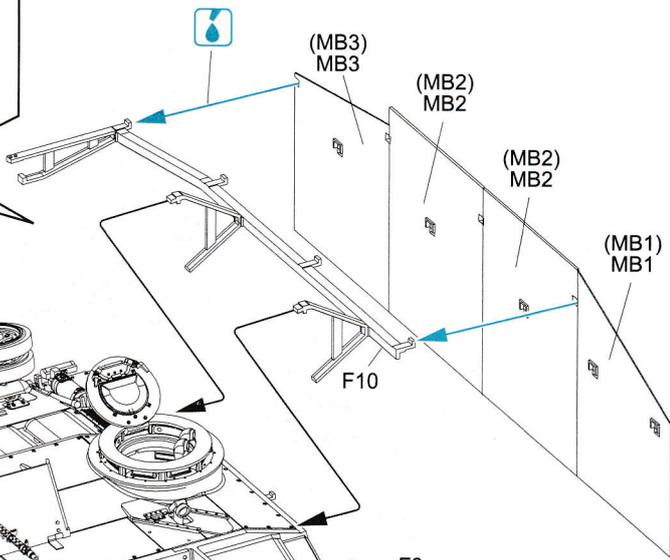
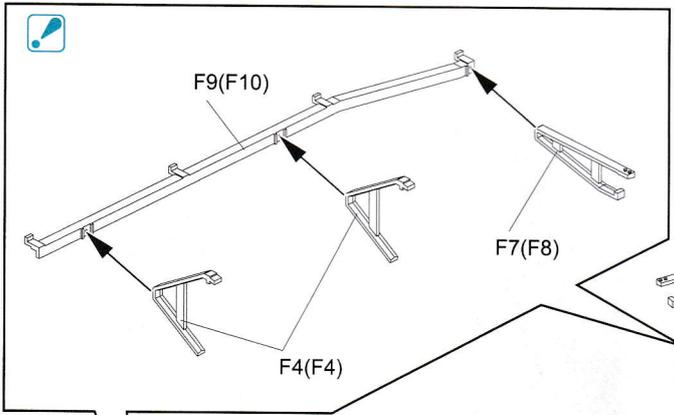
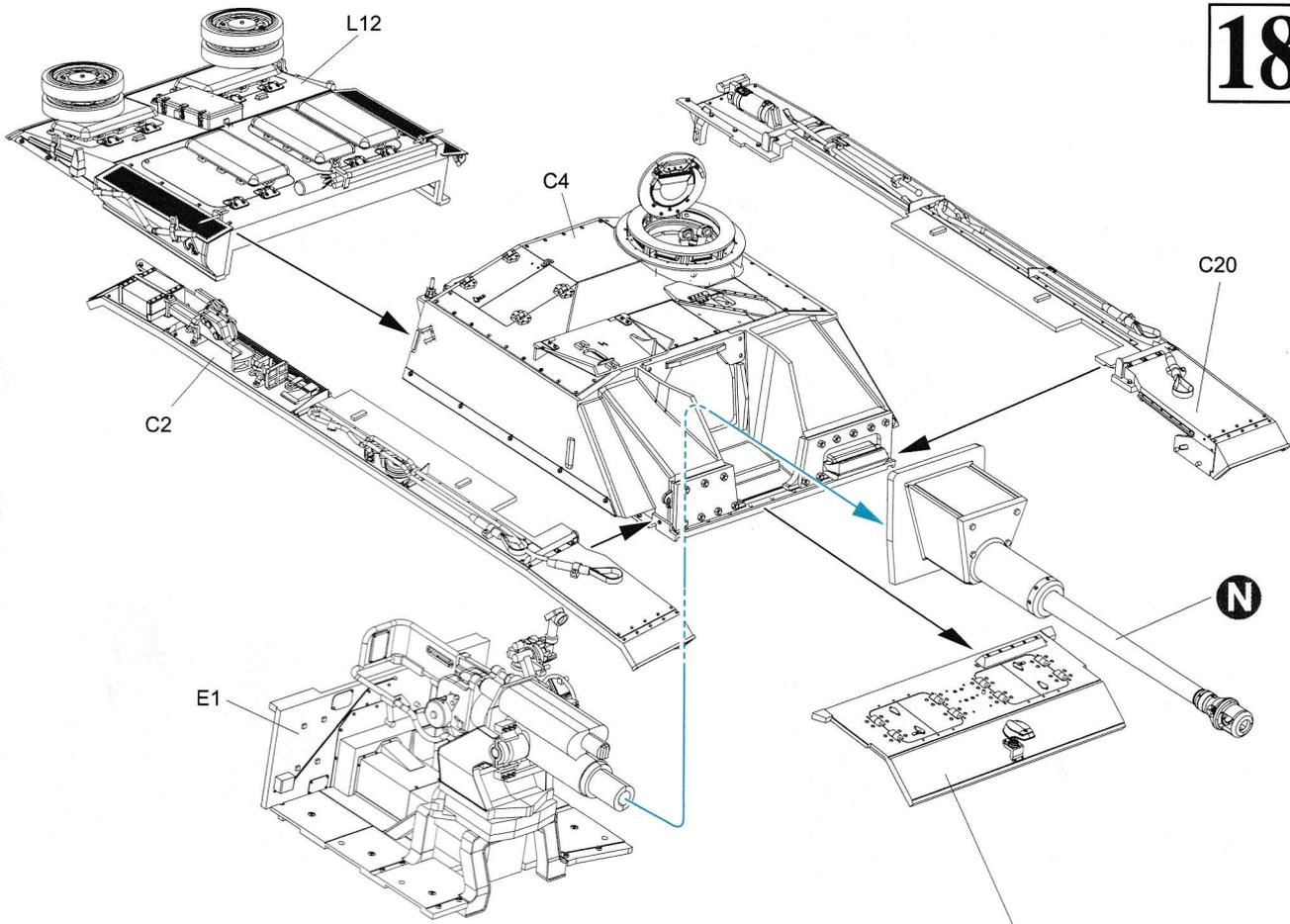



# Painting & Markings

マーキング及び塗装図 Markierungen und Bemalung Decoration et Peinture Marchio & Pittura 標貼及着色指示

Pz.Rgt."Totenkopf", Pz.Gren.Div."Totenkopf", Kursk 1943

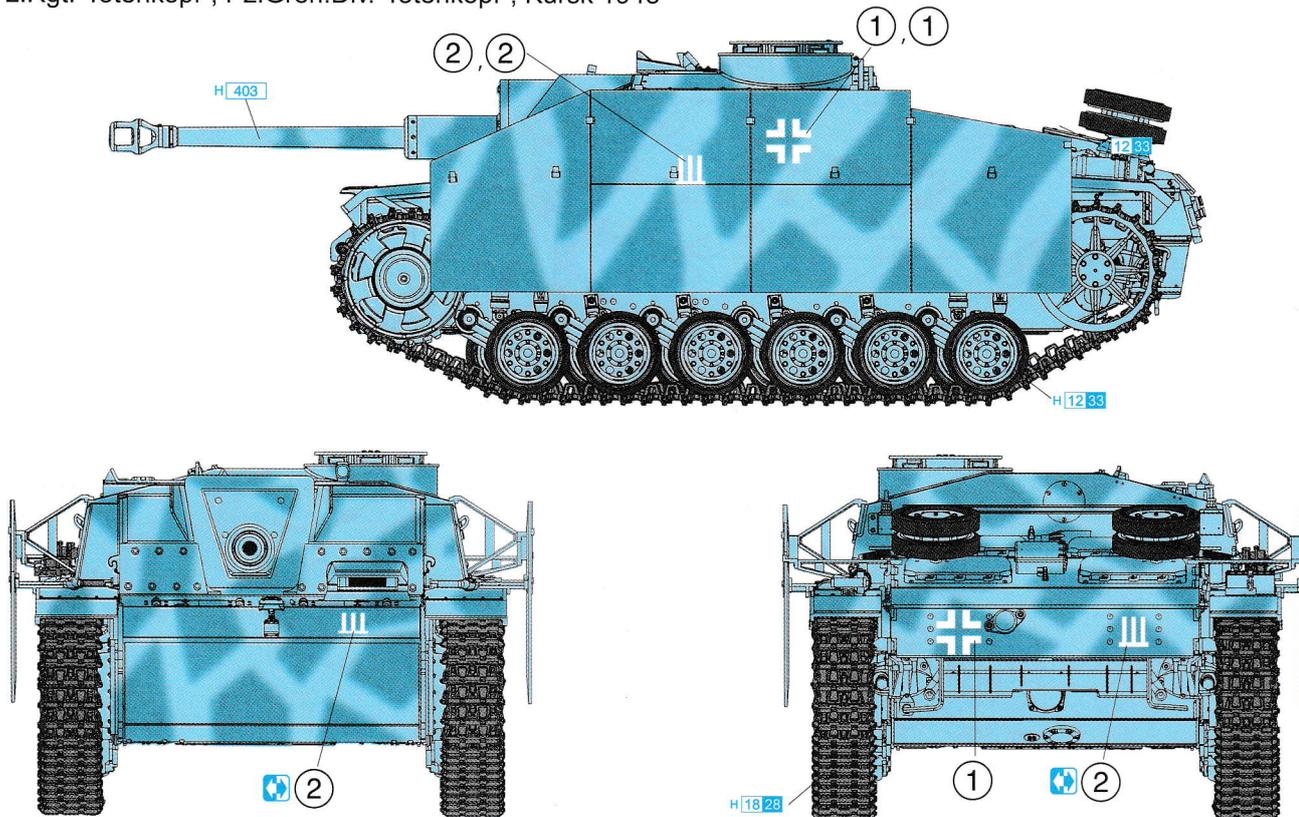

Pz.Abt.215, 15.Pz.Gren.Div., Sicily 1943

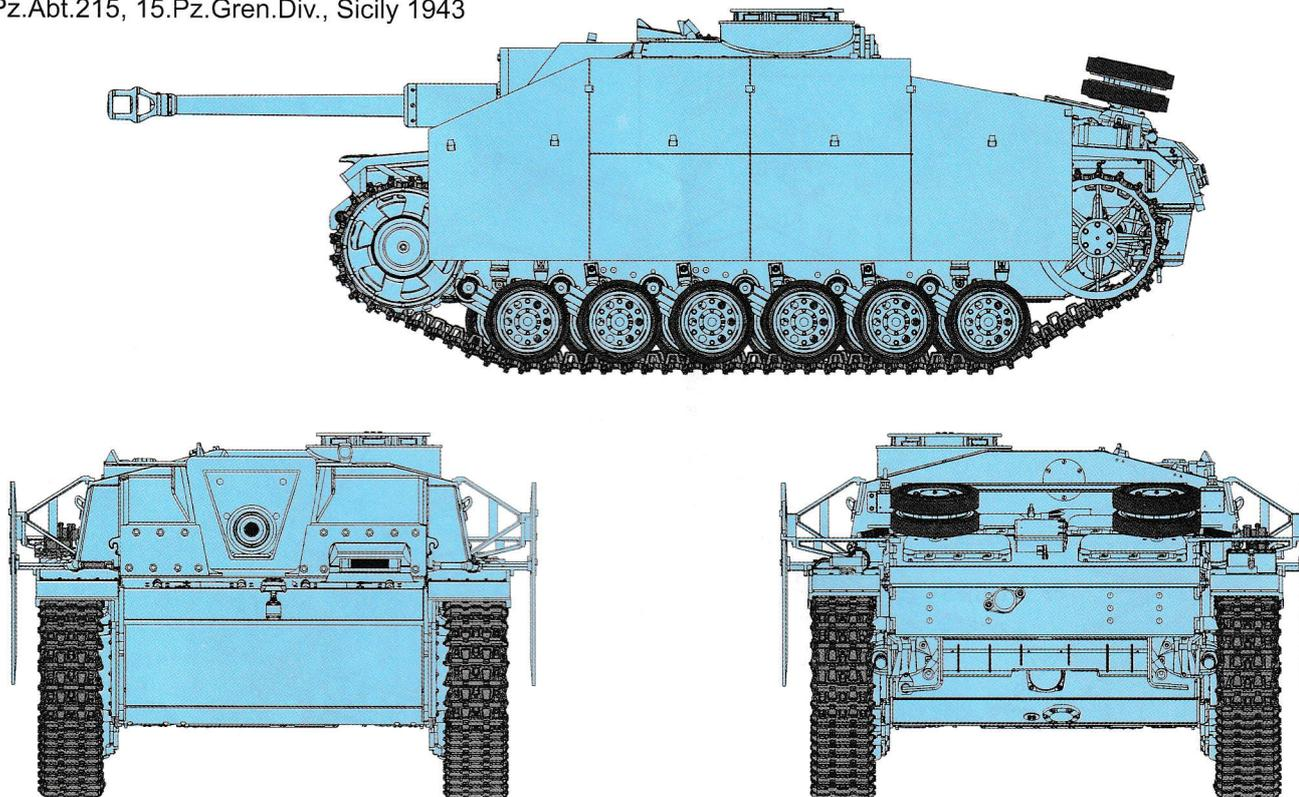

Dragon Europe: c/o Hobby Pro Marketing Ges. m.b.H.  
Am Leonhardbach 7, A-8010 GRAZ, AUSTRIA

 **DRAGON** Copyright ©2014  
6578-01

## ■ デカールの貼り方

- ① あらかじめデカールを貼る場所の汚れを拭き取ってください。
- ② 貼りたいデカールを切り取り、1枚ずつ水、またはぬるま湯に台紙を下に20秒ほど浸します。
- ③ 水から引き上げたらタオル等に乗せ、指先で動かかめます。その後、台紙をずらしながら所定の位置に貼ります。
- ④ 指先に少量の水をつけて微調整した後、柔らかな布等で内側の水分や気泡を押し出してください。
- ⑤ デカールが完全に乾いたら多少の水を含んだ布で、デカールま

## ■ Correct Method for Applying Decals

- ① Clean the model surface with a wet cloth.
- ② Cut out each decal design from the decal sheet, and dip it in warm water for 20 seconds.
- ③ Use a fingertip to check if the decal is loose from the backing paper. If so, place it in the proper position on the model, and slide it off the backing paper onto the model.
- ④ Move the design to the exact position with a wet fingertip, and squeeze out any excess water or air bubbles under the decal with a soft cotton cloth.

## ■ Das Korrekte Aufbringen der Abziehbilder

- ① Oberfläche des Modells mit feuchtem Tuch reinigen.
- ② Jedes Motiv einzeln aus dem Bogen heraus schneiden und 20 Sekunden in warmes Wasser tauchen.
- ③ Mit dem Finger prüfen, ob sich das Motiv vom Trägerpapier gelöst hat. Wenn ja, so schieben Sie es vom Papier weg and seine genaue Position auf dem Modell.
- ④ Korrigieren Sie die exakte Lage mit nasser Fingerspitze und drücken Sie Wasserblasen unter dem Abziehbild mit einem weichen Baumwolltuch weg.