

This detail set allows you to build 1x CBM in one of these configurations:

1. Basic CBM with highly-detailed & empty PE racks (suitable for CBU-87, CBU-97 ...)
2. Upgraded CBM with highly-detailed & empty PE racks (suitable for CBU-105 ...)
3. Basic CBM with simplified & loaded racks (optimized for EDUARD sets 648274, 648275)
4. Upgraded CBM with simplified & loaded racks (optimized for EDUARD sets 648276)

- BEND
- OPTION
- REPEAT „N“-TIMES
- ONLY FOR Basic CBM
- ONLY FOR Upgraded CBM
- 1** PE PART NUMBER
- A** PUR PART LETTER
- ①** DECAL NUMBER

PLEASE READ THESE INSTRUCTIONS CAREFULLY BEFORE YOU BEGIN !

ETCHED (PE) PARTS	RESIN (PUR) PARTS	ORIGINAL KIT PARTS	TUBING / WIRING	PARTS TO REMOVE	SUBASSEMBLY
-------------------	-------------------	--------------------	-----------------	-----------------	-------------

I

II
III
IV

V

VII

VIII

IX

VI

X

XII

XI

XI

XIII

M - USE ONLY IF CBM WILL BE LOADED WITH BOMBS

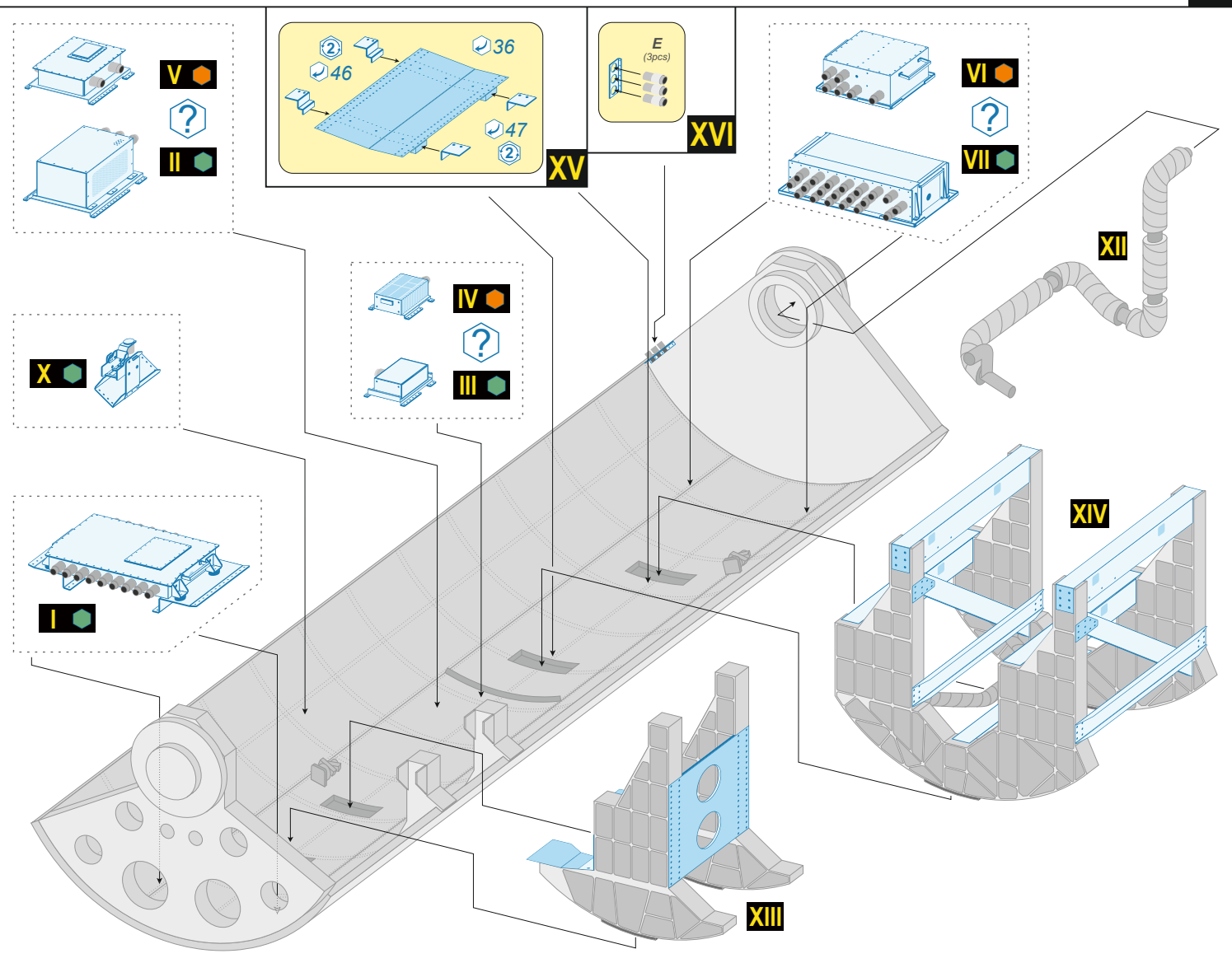
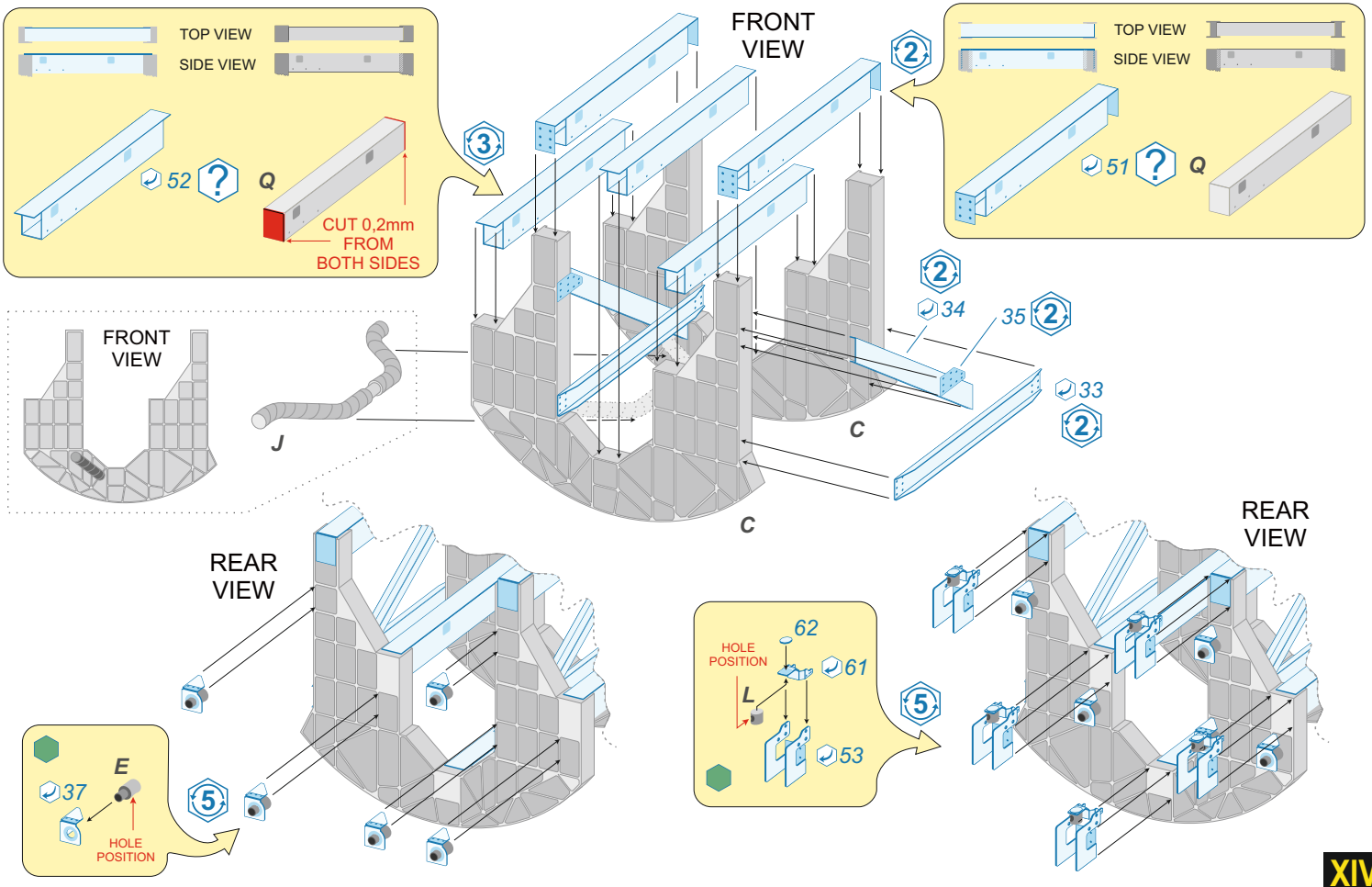

LOCATION OF SUBASSEMBLIES

TOP VIEW

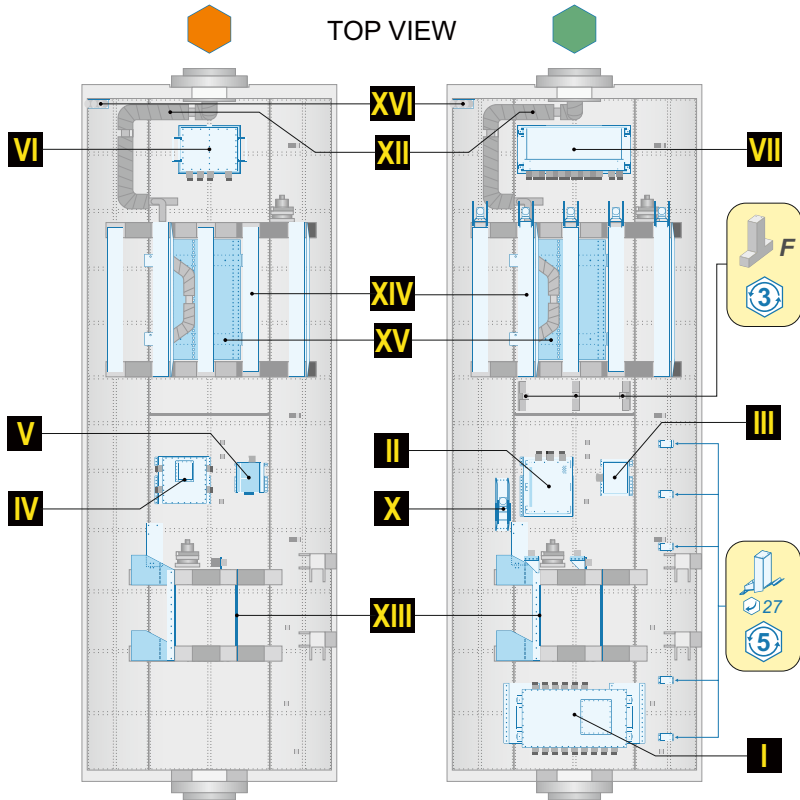

UPGRADED CBM WIRING

SCHEMATIC DIAGRAM

FOR MORE ACCURATE WIRING
LOOK FOR SOME PHOTOS

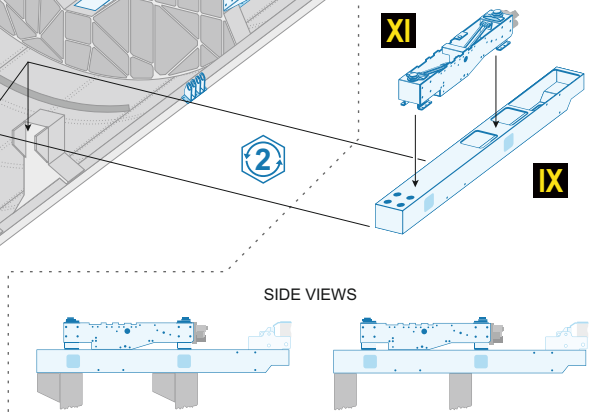
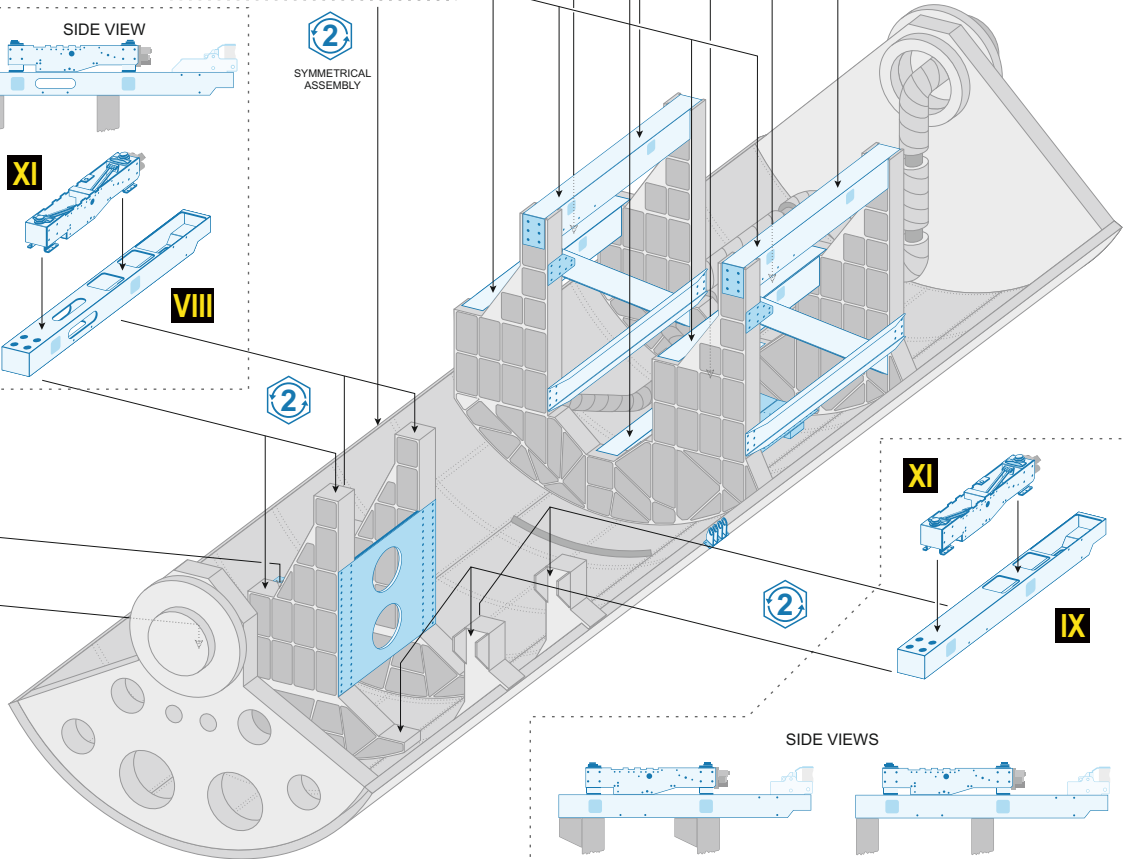
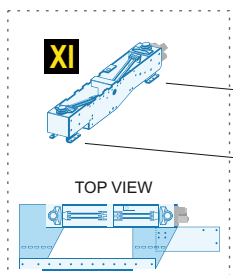
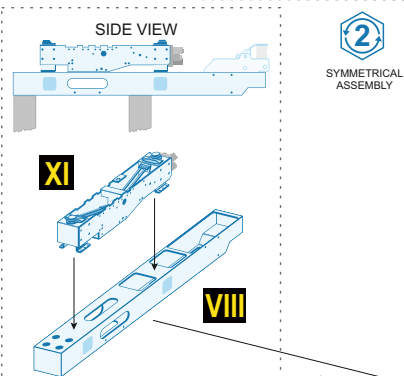
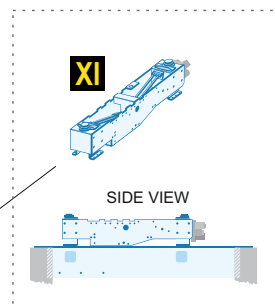
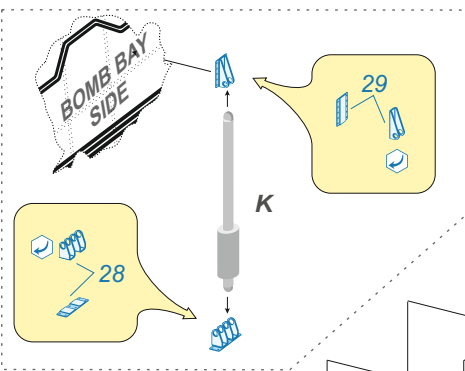
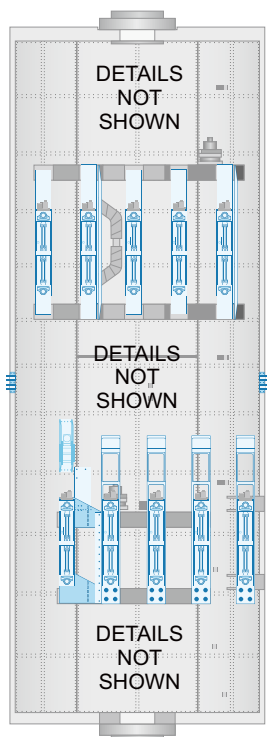
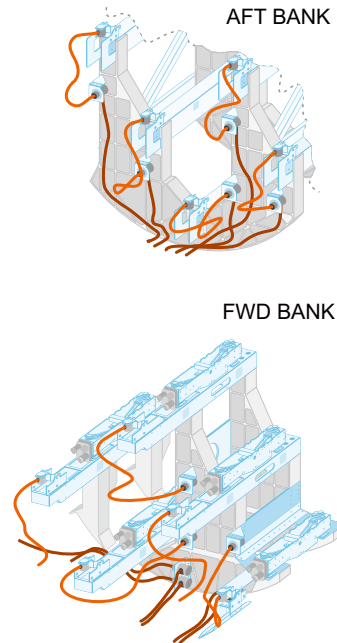
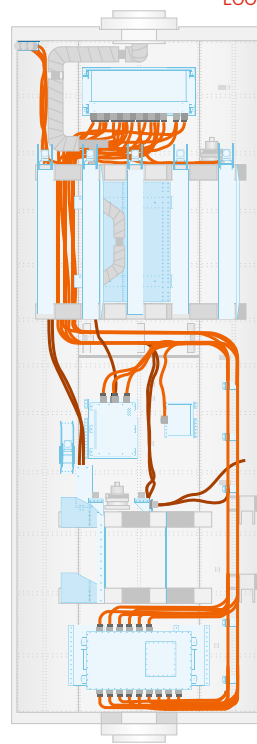

DECALS

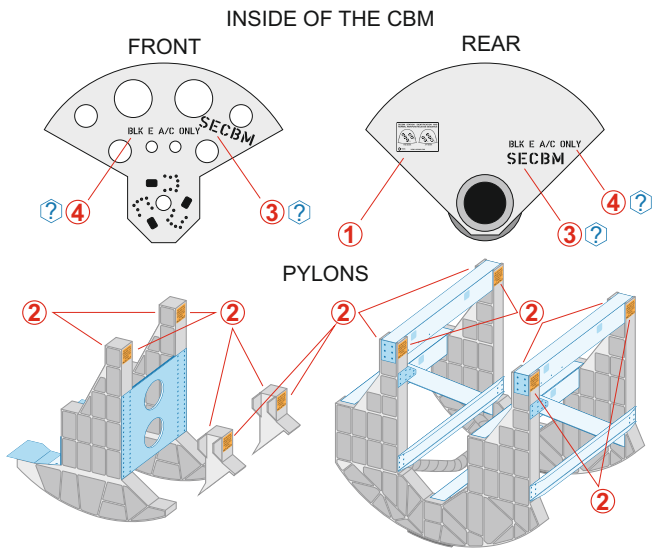

CBU POSITION ON RACK

(CBUs not included in set)

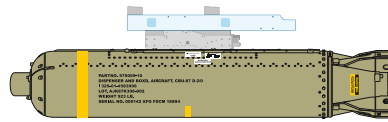

BASIC RACK LOADED WITH **CBU-87**
(EDUARD 648274)

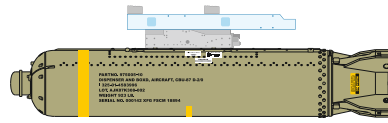

BASIC RACK LOADED WITH **CBU-97**
(EDUARD 648275)

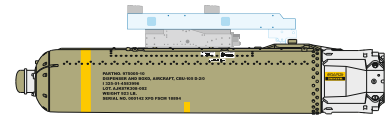

UPGRADED RACK LOADED WITH **CBU-105**
(EDUARD 648276)

WIRE / TUBE BUCKLES (EXTREMELY MAGNIFIED)

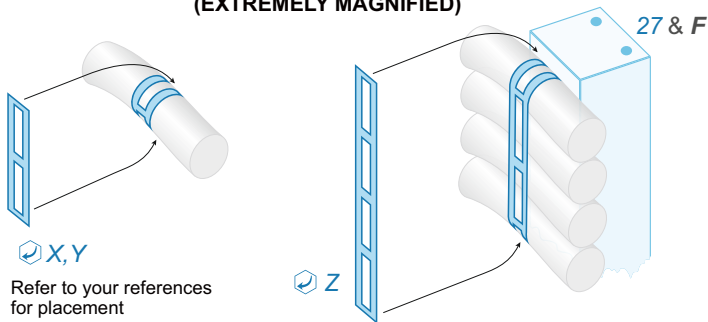

RUBBER THREAD FORMING

● CYANOACRYLATE (CA) GLUE ← CA RESISTANT SHARP STICK

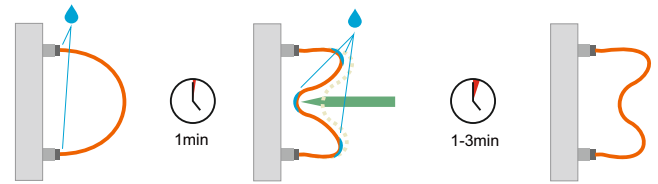

1. Glue thread at the ends with CA glue. Leave to dry.
2. Fix the proper shape with sharp stick (bend more than needed) and cover curves with CA glue. Leave to dry, then release the stick. Repeat as needed.

DETAIL SET BOX CONTENT

RESIN PARTS

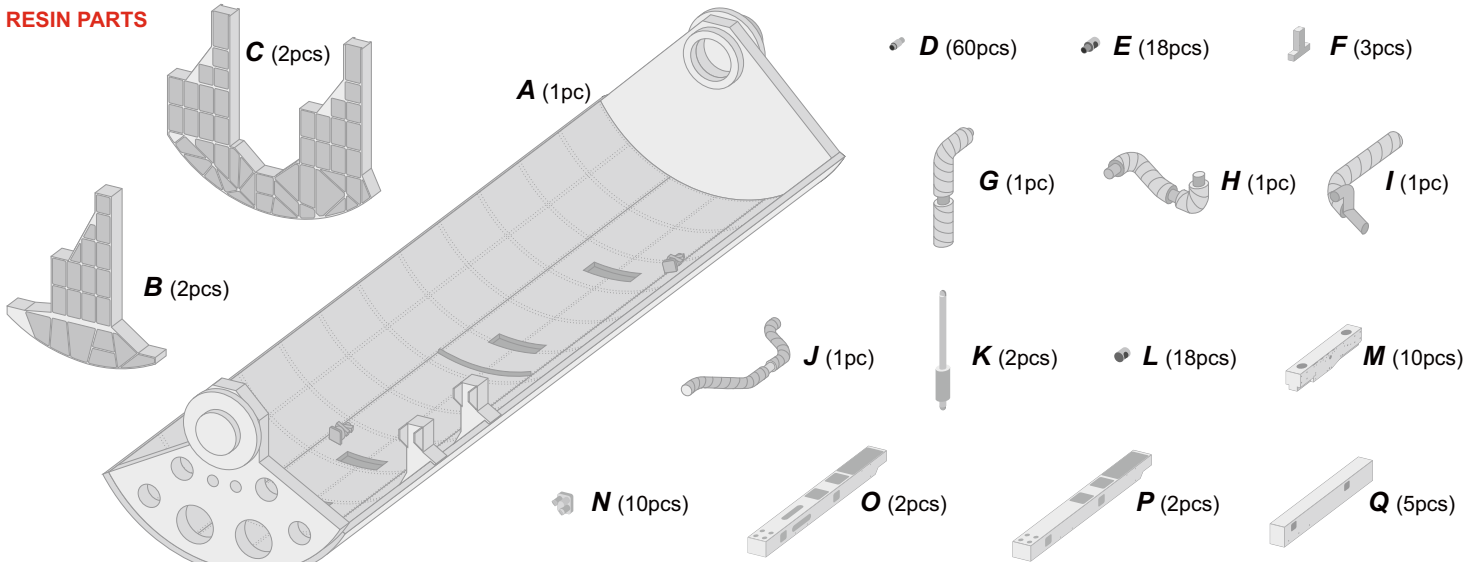

PE SHEET A (Parts 1 to 47)



PE SHEET B (Parts 48 to 68)

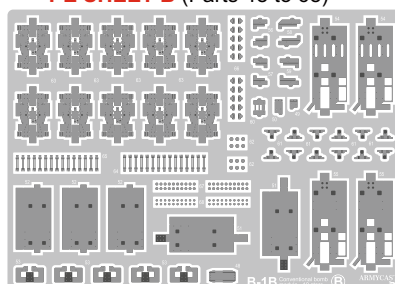

DECAL SHEET



BARE RUBBER THREAD (WHITE)

ø0,36mm, total length >150cm

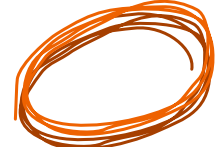

Link to the CBM photo gallery (thanks to Jarrad Bradley)
<https://bone-fragments.com/cbm-photos/>

NOTE This product contains metal and resin detail parts for upgrading your scale plastic model. When upgrading the model some cutting or corrections may be necessary for parts to fit accurately. Always Wash parts before gluing and painting. CA Cyanoacrylate glue is required to glue parts.

WARNING! This set contains small and sharp parts. Work carefully in a ventilated and well-lit room. Safety glasses and dust particle protections are recommended when cutting, scraping or sanding parts. Do not inhale Resin dust or particles. This product is not suitable for children below 14 years of age and beginners. It is intended for experienced and skilled modellers.