

UPPER AIRCRAFT, OUTER WING AND HORIZONTAL STABILIZER- BLUE
 MIDDLE OF AIRCRAFT, FRONT OF PROP BLADES AND COWLING- WHITE
 INNER WING- RED AND WHITE STRIPES
 PROP, BACK AND TIP OF PROP BLADES AND ANTI GLARE PANEL- BLACK

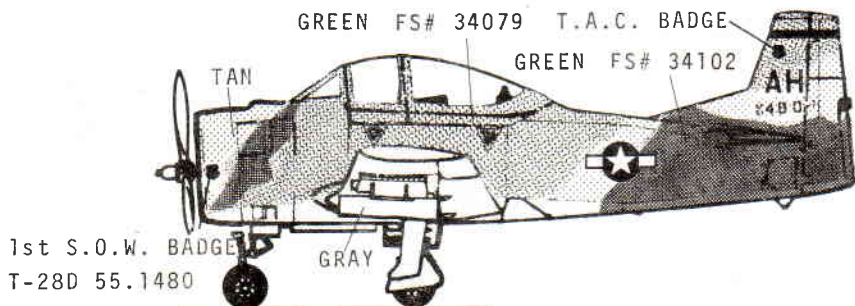

STANDARD CAMOUFLAGE SCHEME
 LOWER FUSELAGE INCLUDING LOWER WING - GRAY FS# 36622
 UPPER AIRCRAFT- GREEN FS# 34079 GREEN FS# 34102 TAN FS# 30219
 FOR FURTHER INFORMATION REFER TO THE NORTH
 AMERICAN T-28 BY STEVE GINTHER

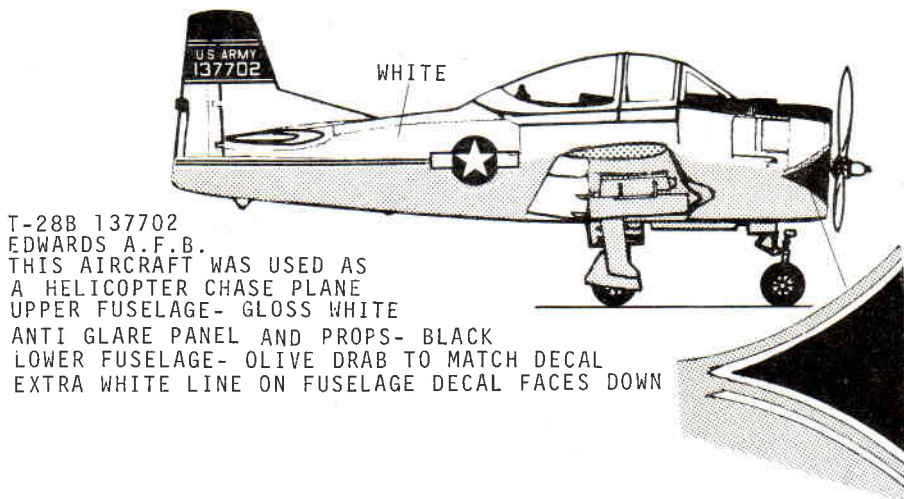

TO SHOW DECAL PLACEMENT ONLY

LOWER STARBOARD

T-28B 137702

T-28B 138155

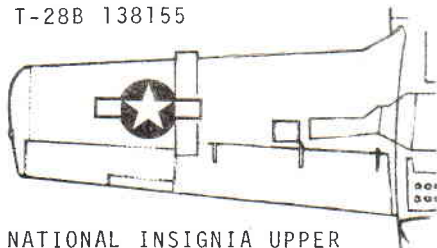

NATIONAL INSIGNIA UPPER
PORT LOWER STARBOARD
USE SMALL NATIONAL INSIGNIA
IN NORMAL PLACEMENT

T-28D 55.1480

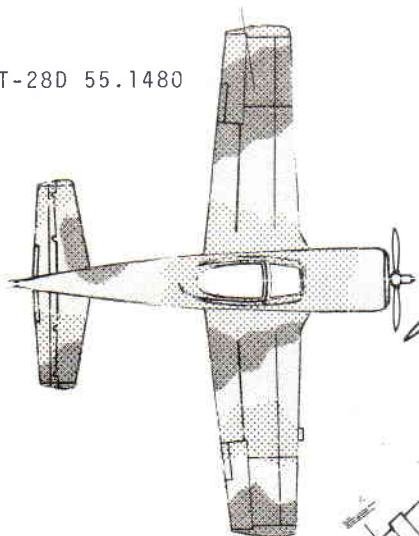

RESEARCH BY DON GARRETT
RECOMMENDED KIT
HELLER- T-28

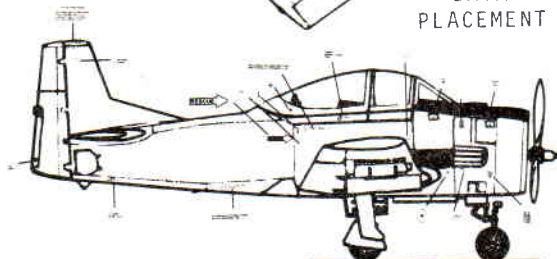

TO SHOW DECAL PLACEMENT AND
UPPER/LOWER PAINT SCHEME

UPPER STARBOARD

T-28B 138155

WHITE NAVY

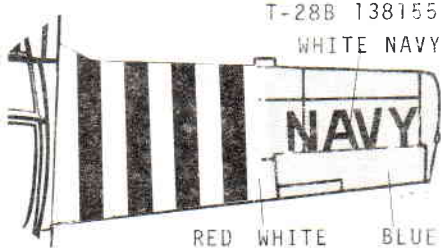

RED WHITE BLUE

OLIVE DRAB T-28B 137702

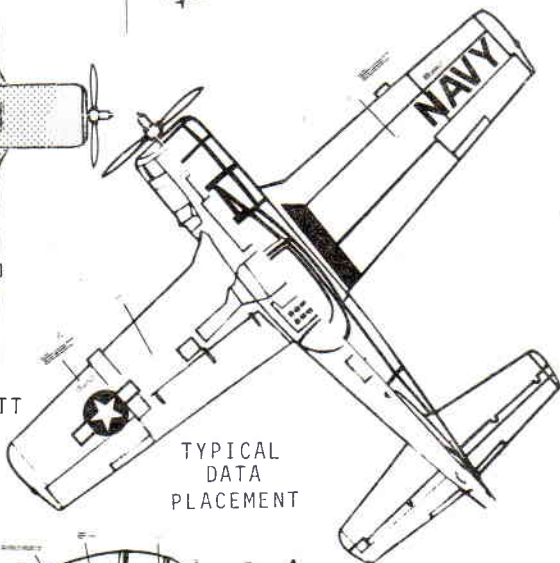

TYPICAL
DATA
PLACEMENT