

**ITALERI**

MADE IN ITALY, I-40012 CALDERARA DI RENO (BO)

**1:35 Scale No 319**

# 105 MM HOWITZER

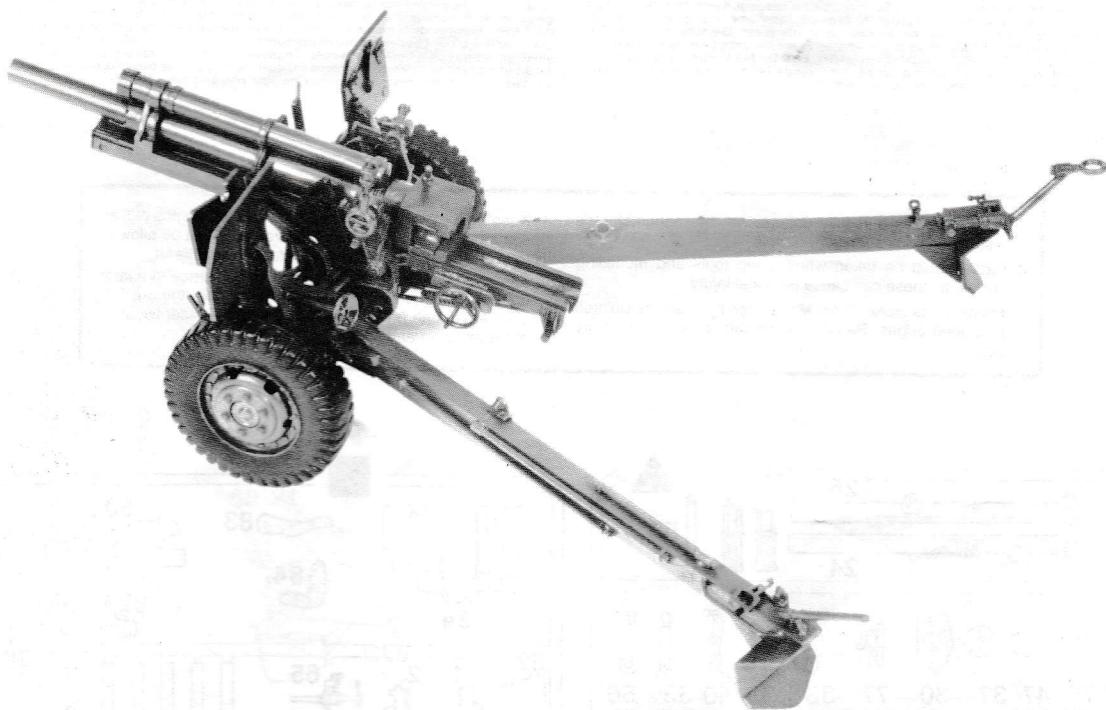

**105 mm HOWITZER M 101** - Il tipo "Obice cal. 105 mm M 101" fu sviluppato prima dell'inizio della Seconda Guerra Mondiale. La produzione fu completata nel 1953 e per quell'anno ne furono costruiti 10202 esemplari. Il cannone da 105 mm fu montato su molti carri semoventi incluso il "M-7" ("Priest" nostro art. No. 206). Questo cannone fu usato ed è ancora utilizzato da più di cinquanta Nazioni, includendo quasi tutte le appartenenti alla NATO. Esso fu uno dei più famosi pezzi da campo delle forze Alleate durante la Seconda Guerra Mondiale.

**Caratteristiche Tecniche:** Calibro: 105 mm.; Peso del pezzo in batteria: 2222 kg.; Peso del pezzo completo al traino: 2258 Kg.; Lunghezza del pezzo completo al traino: 5,994 m.; Larghezza del pezzo completo al traino: 2,159 m.; Larghezza del pezzo in batteria: 3,657 m.; Altezza del pezzo completo al traino: 1,974 m.; Scarto: 1,778 m.; Lunghezza della canna: 2,592 m.; Lunghezza di tiro: 11.000 m.; Equipaggio: No. 8 Uomini.

**105 MM HOWITZER M 101** - The 105MM Howitzer was developed well before the start of World War II. The production was completed in 1953 by which time 10202 had been built. The 105 mm gun was mounted on many self-propelled chassis including the M-7 ("Priest", No. 206). The gun was and is still being used by more than 50 countries including practically all Nato Allies. It was one of the most successful field pieces of the Allied forces during World War II.

**Technical Data:** Calibre: 105 mm.; Weight Firing: 2222 kg.; Weight Travelling: 2258 kg.; Length Travelling: 5994 mm.; Width Travelling: 2159 mm.; Width Firing: 3657 mm.; Height Travelling: 1974 mm.; Track: 1778 mm.; Barrel Length: 2592 mm. Range: 11000 m.; Crew: 8.

**105 MM HAUBITZE M 101** - Die 105 MM Haubitze wurde bereits lang vor dem 2. Weltkrieg entwickelt. Die Produktion wurde 1953 beendet. Bis zu diesem Zeitpunkt wurden 10202 Einheiten erzeugt. Die 105 mm Kanone war auf vielen Panzerfahrzeugen angebracht, einschließlich dem M-7 ("Priest", No. 206). Die Kanone wurde und wird noch immer von mehr als 50 Ländern einschließlich praktisch aller NATO-Alliierten verwendet. Sie war eine der erfolgreichsten alliierten Geschütze des 2. Weltkrieges.

**Technische daten:** Kaliber: 105 mm.; Gewicht, Feuerstellung: 2222 kg.; Gewicht, Fahrstellung: 2258 kg.; Länge, Fahrstellung: 5994 mm.; Breite, Fahrstellung: 2159 mm.; Breite, Feuerstellung: 3657 mm.; Höhe, Fahrstellung: 1974 mm.; Spur: 1778 mm.; Rohrlänge: 2592 mm.; Reichweite: 11.000 m.; Mannschaft: 8.

**105 MM HOWITZER M 101** - Le "Howitzer" 105 mm fut conçu bien avant le début de la Seconde Guerre Mondiale. Sa fabrication se prolongea jusqu'en 1953; il en fut constitué 10202 exemplaires. Ce canon de 104 mm fut monté sur de nombreux châssis automoteurs, y compris le M-7 ("Priest", No. 206). Cette pièce d'artillerie était, et est toujours, utilisé par plus de 50 nations, dont presque tous les membres de l'OTAN. Ce fut l'une des meilleures pièces d'artillerie des Forces Alliées pendant la Seconde Guerre Mondiale.

**Spécifications techniques:** Calibre: 105 mm.; Poids en position de tir: 2222 kg.; Poids en position de déplacement: 2258 kg.; Largeur en position de tir: 3,657 m.; Dimensions en position de déplacement: longueur 5,994 m.; Largeur 2,159 m, hauteur 1,974 m.; Ecartement: 1,778 m.; Longueur du canon: 2,592 m.; Portée 11.000 m.; Equipage: 8 hommes.

### ATTENZIONE - Consigli utili!

Prima di iniziare il montaggio, studiare attentamente il disegno. Staccare con molta cura i pezzi dalle stampe, usando un taglia-balsa oppure un paio di forbici e togliere con una piccola lima o con carta vetro fine eventuali sbavature. Mai staccare i pezzi con le mani. Montarli seguendo l'ordine della numerazione delle tavole. Eliminare dalla stampata il numero del pezzo appena montato, facendogli sopra una croce. Le frecce nere indicano i pezzi da incollare, le frecce bianche indicano i pezzi da montare senza colla. Usare solo colla per polistirolo. ▲●■ I contrasegni ai lati dei numeri indicano la stampata ove si trova il pezzo da montare. I pezzi sbarrati da una croce non sono da utilizzare.

### ACHTUNG - Ein nützlicher Rat!

Vor der Montage die Zeichnung aufmerksam studieren. Die einzelnen Montageteile mit einem Messer oder einer Schere vom Spritzling sorgfältig entfernen. Eventuelle Grate werden mit einer Klinge oder feinem Schmirgelpapier beseitigt. Keinesfalls die Montageteile mit den Händen entfernen. Bei der Montage der Teile in der Reihenfolge der Nummern der schon montierten Teile auf dem Spritzling ankreuzen. Die schwarzen Pfeile zeigen die zu klebenden Teile während die weißen Pfeile die ohne Leim zu montierenden Teile anzeigen. Bitte nur Plastikklebstoff verwenden. ▲●■ Die Markierung neben den Nummern zeigt auf welchem Spritzling der zu montierende Teil zu finden ist. Die mit einem Kreuz markierten Teile sind nicht zu verwenden.

### ATTENTION - Useful advice!

Study the instructions carefully prior to assembly. Remove parts from frame with a sharp knife or a pair of scissors and trim away excess plastic. Do not pull off parts. Assemble the parts in numerical sequence. Use plastic cement ONLY and use cement sparingly to avoid damaging the model. Black arrows indicate parts to be glued together. White arrows indicate that parts must be assembled WITHOUT using cement. ▲●■ These marks indicate on which frame the parts will be found. Paint small parts before detaching them from frame. Remove paint where parts are to be cemented. Crossed out parts must not be used.

### ATTENTION - Conseils utiles!

Avant de commencer le montage, étudier attentivement le dessin. Détacher avec beaucoup de soin les morceaux des moules en usant un massicot ou bien un pair de ciseaux et couper avec une petite lame ou avec de papier de verre fin ébarbagés éventuels. Jamais détacher les morceaux avec les mains. Monter les en suivant l'ordre de la numération des tables. Eliminer de la moule le numero de la pièce qui vient d'être montée, en le bifant avec une croix. Les fleches noires indiquent les pieces a coller, les fleches blanches indiquent les pieces a monter sans colle. Employer seulement de la colle pour polystyrol. ▲●■ Les signes aux cotes des numeros indiquent la moule ou se trouve la pieces a monter. Les pieces marquées par une croix ne sont pas a utiliser.

1. Read carefully and fully understand the manufacturer's instruction book supplied with this kit.
2. Care should be taken when using tools and modelling knives, as these can cause personal injury.
3. Plastic parts broken from sprues can have sharp, pointed or jagged edges. Remove these with a file or an emery board.

4. Keep out of the reach of children under 36 months old, as some parts are detachable. Children must not be allowed to suck any metal part or wire included with this kit.
5. This document should be retained for reference at a later date, if the need arises, as it includes the "EEC" company name and address as a means of identification of the importer and supplier.

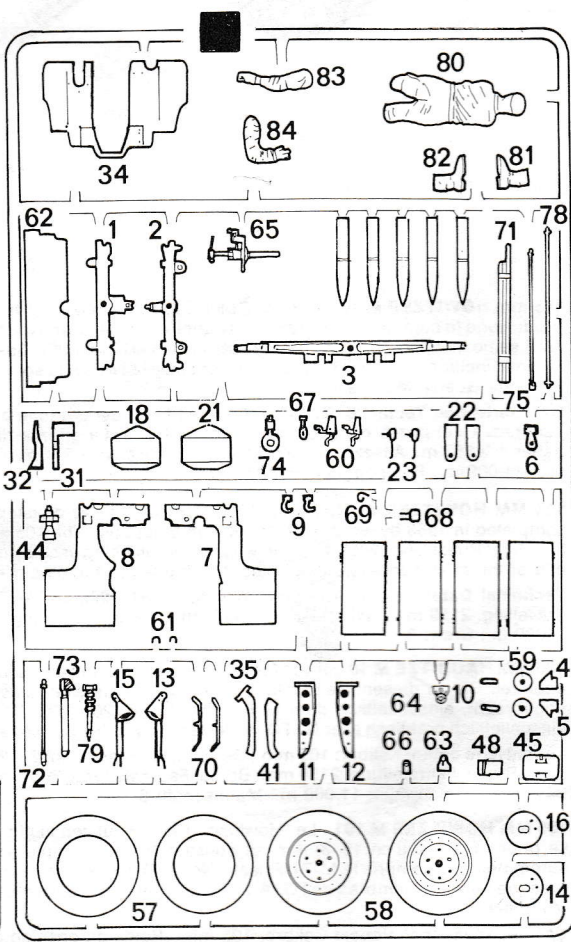
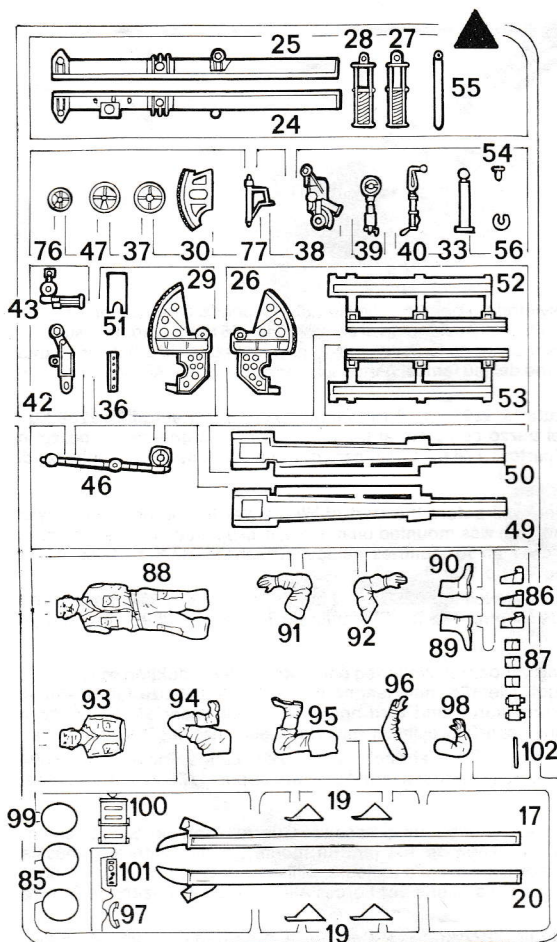

# 1 1-10

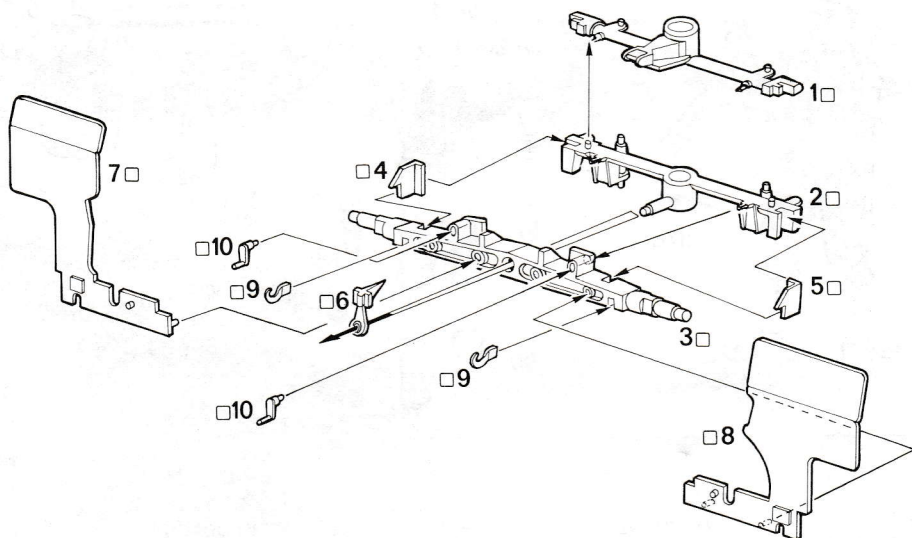

# 2 11-23

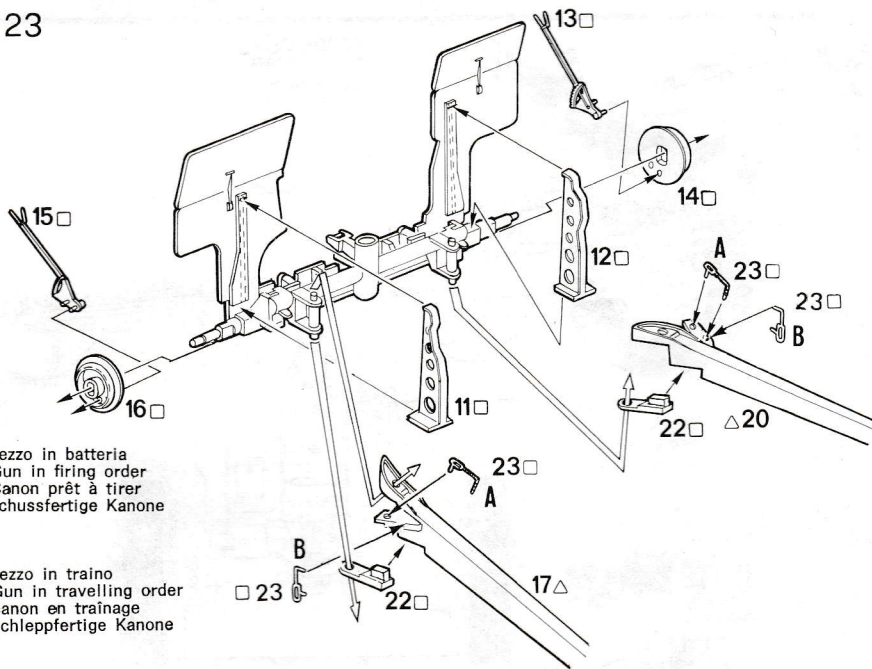

**A** Pezzo in batteria  
Gun in firing order  
Canon prêt à tirer  
Schussfertige Kanone

**B** Pezzo in traino  
Gun in travelling order  
Canon en trainage  
Schleppfertige Kanone

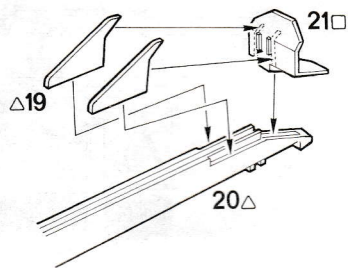
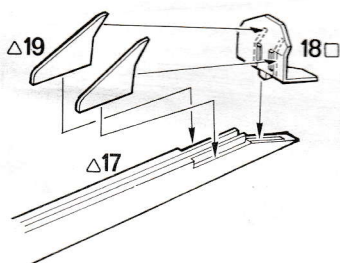

### 3 24·33

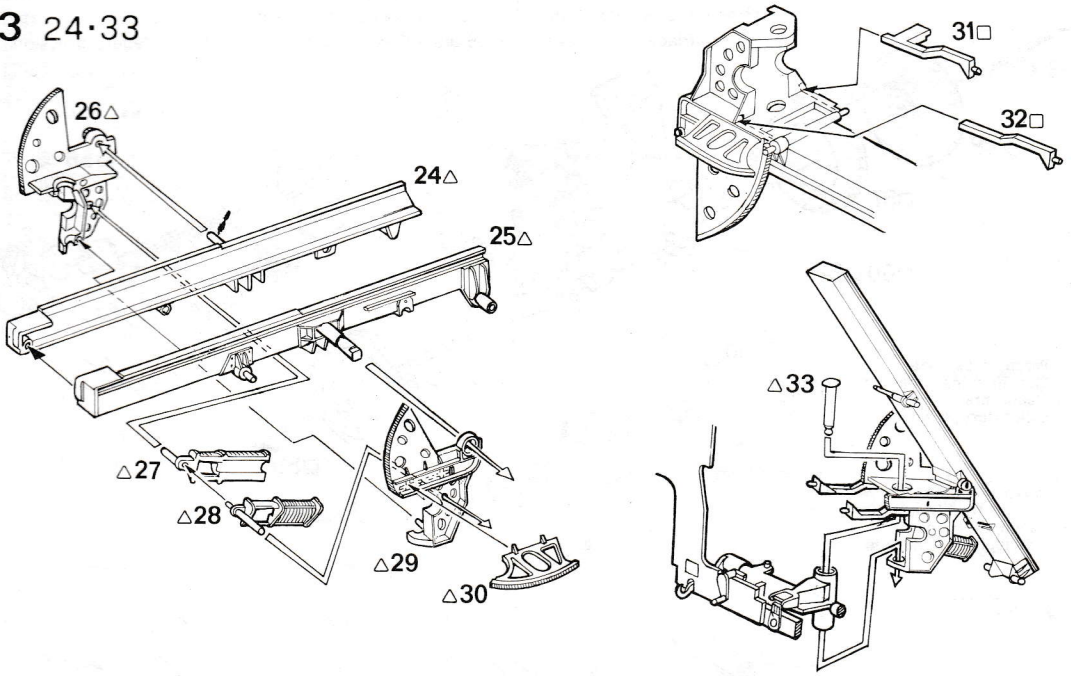

### 4 34·54

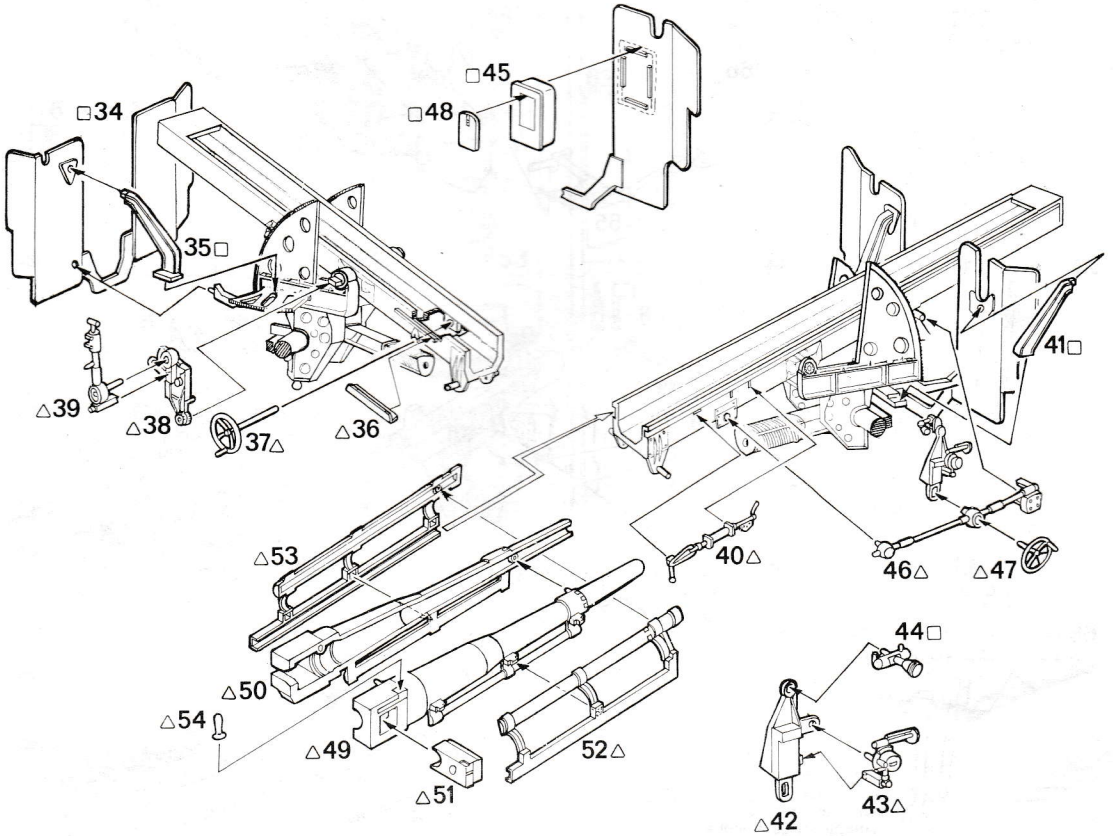

## 5 55-66

I pezzi 55 e 56 vanno montati nella loro sede, esercitando una leggera pressione.  
 To assemble the pieces 55 and 56, push them into their seat with a slight pressure.  
 Die Stücke 55 und 56 durch leichten Druck einsetzen.  
 Placez les pièces 55 et 56 dedans leur place en exerçant une légère pression.

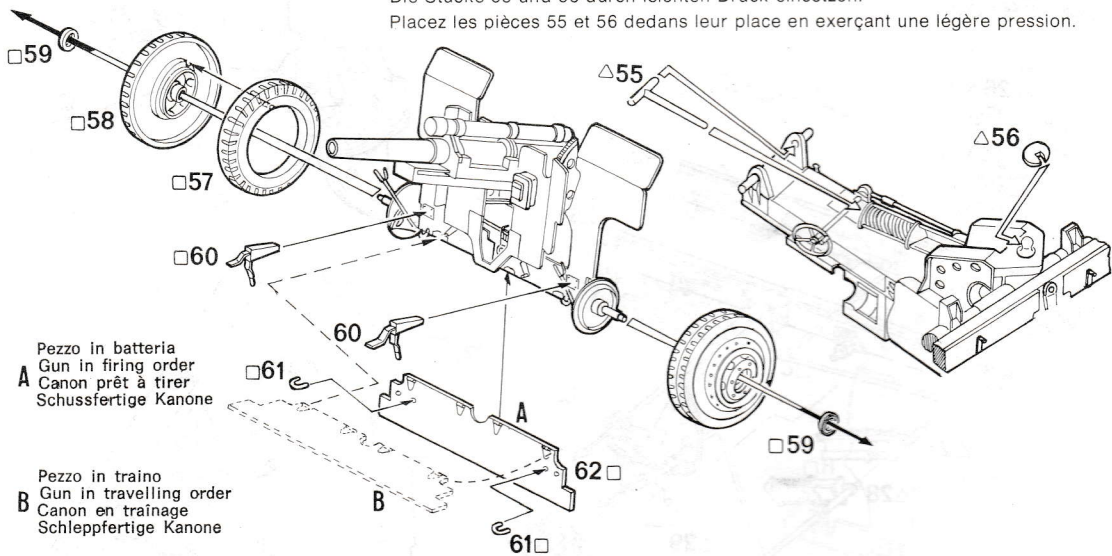

## 6 67-79

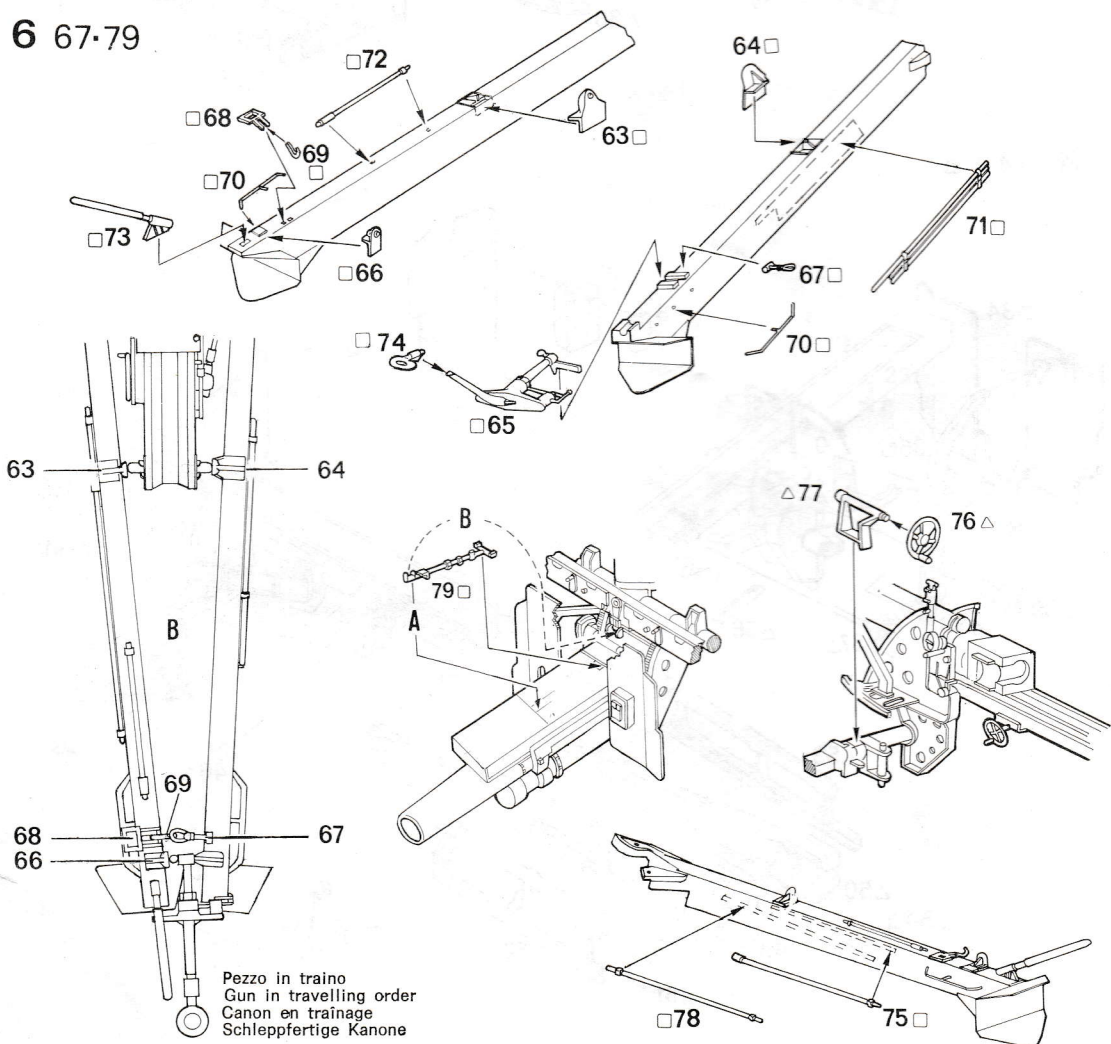

7 80-103

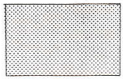
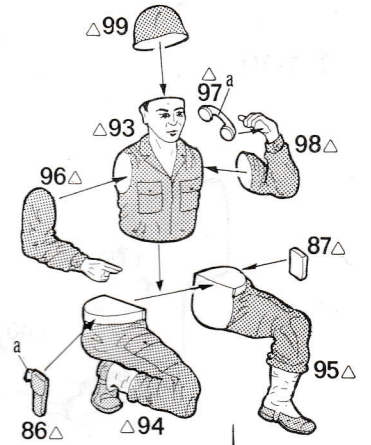
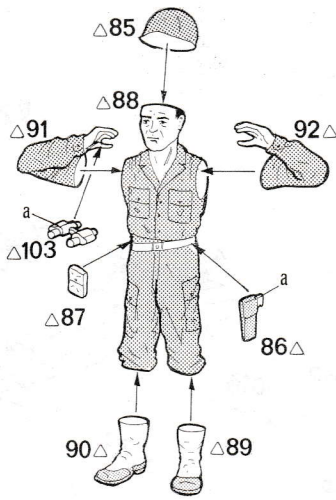
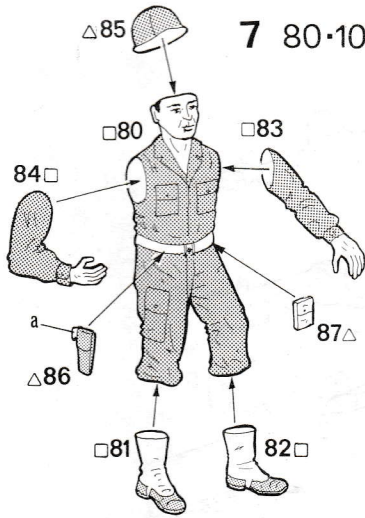

VERDE OLIVA  
OLIVE DRAB  
OLIVGRUEN  
VERT OLIVE

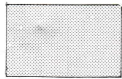

MARRONE  
BROWN  
BRAUN  
MARRON



KAKI  
KHAKI

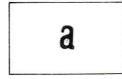

NERO OPACO  
FLAT BLACK  
MATTSCHWARZ  
NOIR OPAQUE

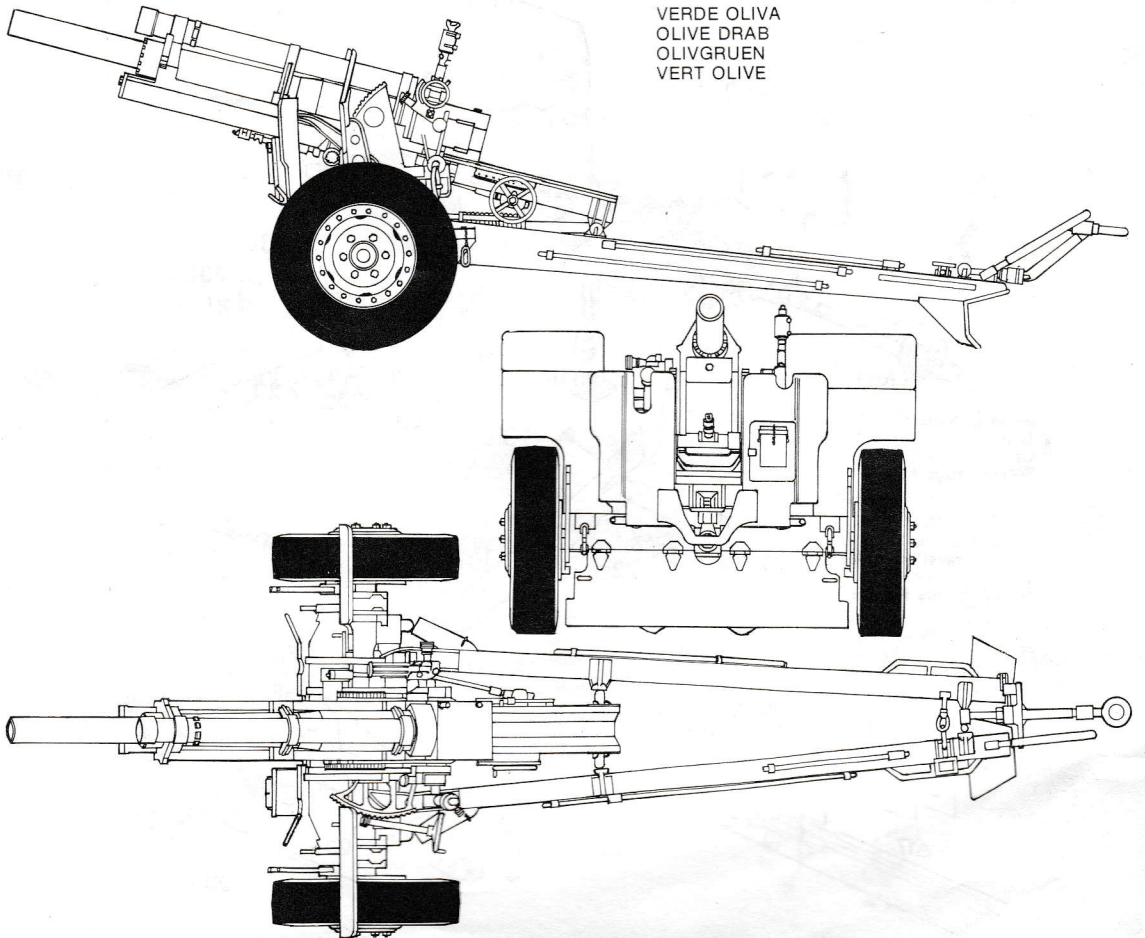
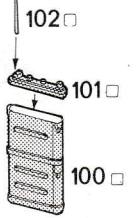

VERDE OLIVA  
OLIVE DRAB  
OLIVGRUEN  
VERT OLIVE