



Ju 88D-1

Германский самолет-разведчик II MB

В начале 30-х годов в мире возникла идея создания скоростного бомбардировщика, который мог бы обогнать современные ему истребители-бипланы. Одним из воплощений этой концепции стал двухмоторный бомбардировщик Ju 88, разработанный германской фирмой Юнкерс Флюгzeug – унд Моторенверке.

С весны 1941 г. началось производство самолетов Ju 88A-4 с усиленным вооружением, на которых были установлены двигатели жидкостного охлаждения Jumo 211J увеличенной мощности.

На базе Ju 88A-4 строились дальние самолеты-разведчики, получившие обозначение Ju 88D-1.

Тактико-технические характеристики Ju 88D-1

Длина, м	14,36
Размах крыла, м	20,08
Взлетный вес, кг	14000
Двигатель	2xJumo 211J, 1400 л.с.
Максимальная скорость, км/ч	467
Потолок, м	8500
Дальность, км	2500
Вооружение	4x7,92-мм пулемета MG 81, до 2900 кг бомб

ВНИМАНИЕ!

Перед сборкой внимательно прочитать руководство по монтажу. Каждая деталь пронумерована. Соблюдать последовательность монтажа. Необходимые рабочие инструменты: нож и напильник для зачистки деталей; резиновая лента, клейкая лента и зажимы для сушки белья для прижимания склеиваемых деталей. Детали из пластика очистить в растворе мягкого моющего средства и высушить на воздухе для того, чтобы краска и переводные картинки лучше прилипали. Перед приклеиванием проверить, подходят ли детали; клей наносить экономно. Хром и краску удалить с поверхностей склеивания. Небольшие детали покрасить перед тем, как они будут удалены из рамок. Краску необходимо хорошо просушить, только после этого продолжать сборку. Каждую соответствующую переводную картинку отдельно вырезать и примерно на 20 секунд окунуть в теплую воду. На обозначенном месте картинку отделить от бумаги и прижать промокающей бумагой.

ИСПОЛЬЗУЕМЫЕ КРАСКИ / USED COLORS:

	Revell	Tamiya		
A	108	XF1	Черный, матовый	Flat Black
B	105	XF2	Белый, матовый	Flat White
C	115	XF3	Желтый, матовый	Flat Yellow
D	140	XF27	Черно-зеленый RLM 70	Schwarzgrun RLM70
E	139	XF61	Темно-зеленый RLM71	Dunkelgrun RLM71
F	149	XF23	Голубой RLM65	Hellblau RLM65
G	177	XF84	Черно-серый, матовый	Schwarzgrau RLM66

Ju 88D-1

WWII German Reconnaissance Plane

In the beginning of 30s it was appeared in the world an idea of high-speed bomber that could outstrip contemporary fighters. One of the objectifications of this conception became the twin-engine bomber Ju 88 designed by a German Junkers Flugzeug - und Motorenwerke AG company.

Since the spring of 1941 it were produced Ju 88A-4 planes with liquid-cooled Jumo 211J engines of increased power and more powerful armament.

On the basis of Ju 88A-4 built long-range reconnaissance aircraft, designated Ju 88D-1.

Tactical and Technical Specifications of Ju 88D-1

Length, m	14,36
Span, m	20,08
Start Weight, kg	14000
Engine	2xJumo 211J, 1400 hp
Max. Speed, km/h	467
Service Ceiling, m	8500
Range, km	2500
Armament	4x7,92 mm MG 81, bomb load - up to 2900 kg

CAUTION!

Read the instructions thoroughly prior to assembly. Each component is numbered. Adhere to specified sequence of assembly. Tools required: knife and file for removal of components from frame; rubber bond, adhesive tape and clothes pegs for clamping components together after applying adhesive. Clean plastic components in a mild detergent solution and allow to air-dry so that paint and transfers adhere better. Prior to applying adhesive, check to see whether the components fit together; apply adhesive sparingly. Remove chrome and paint from the contact surfaces. Paint small components before removing them from the frame. Allow paint to dry well, and only then continue to assemble. Cut out each transfer individually and immerse in warm water for approx. 20 seconds. Slide transfer off paper and into designated position, then press on with blotting paper.

	Revell	Tamiya		
H	145	XF22	Серо-зеленый RLM02	Grau RLM02
J	199	XF16	Алюминий, полуматовый	Aluminium
K	191	X11	Сталь	Steel
L	109	X10	Темный металл	Gun Metal
M	183	XF64	Ржавчина	Rust
N	330	XF7	Красный, матовый	Flat Red
P	364	XF26	Зеленый, матовый	Flat Green
Q	117	XF59	Темно-песочный	Africa Brown

01 СТАДИЯ СБОРКИ
ASSEMBLY STEP

NE НЕ КЛЕИТЬ
DO NOT CEMENT

PH ПРОСВЕРЛИТЬ
OPEN HOLE

PS ОТРЕЗАТЬ
CUT OFF

03 СБОРОЧНАЯ ЕДИНИЦА
ASSEMBLY UNIT

x2 СДЕЛАТЬ ДВЕ ДЕТАЛИ
MAKE 2 PCS

SB СДЕЛАТЬ САМОМУ
SCRATCH BUILD

A ИСПОЛЬЗУЕМАЯ КРАСКА
USED COLOR

NU ПРИ СБОРКЕ НЕ ИСПОЛЬЗУЕТСЯ
PARTS NOT FOR USE

OP ПРОИЗВОЛЬНЫЙ ВЫБОР
OPTIONAL

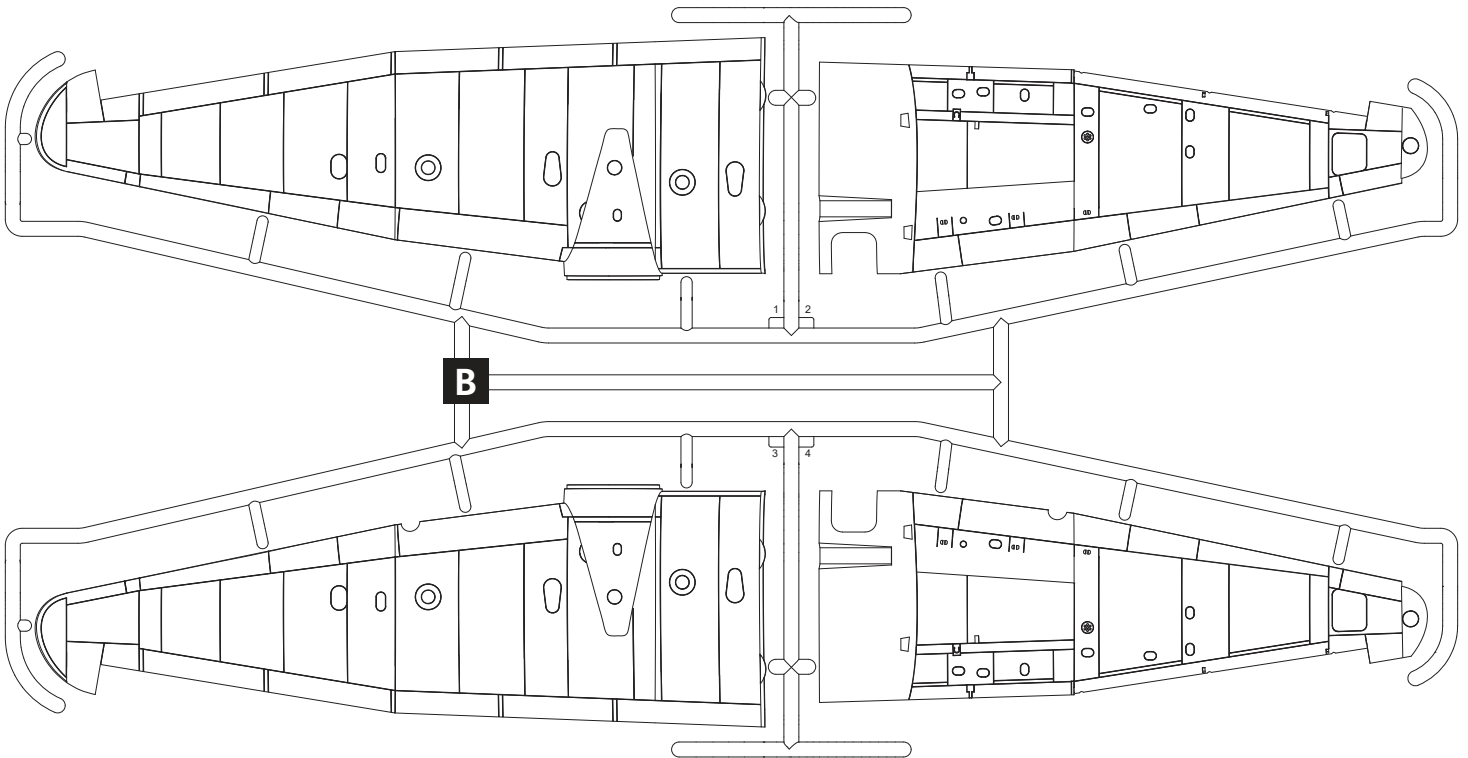
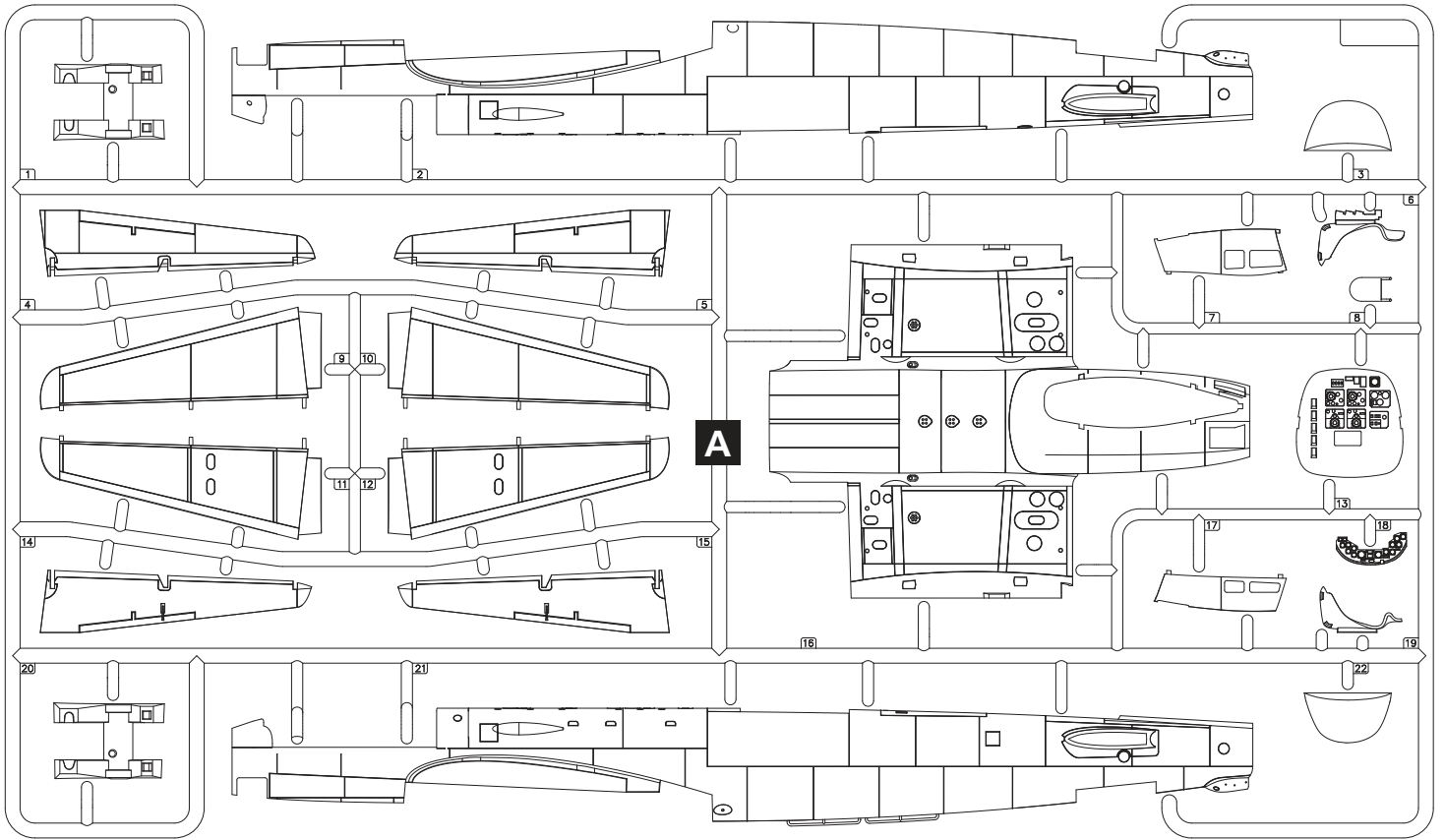

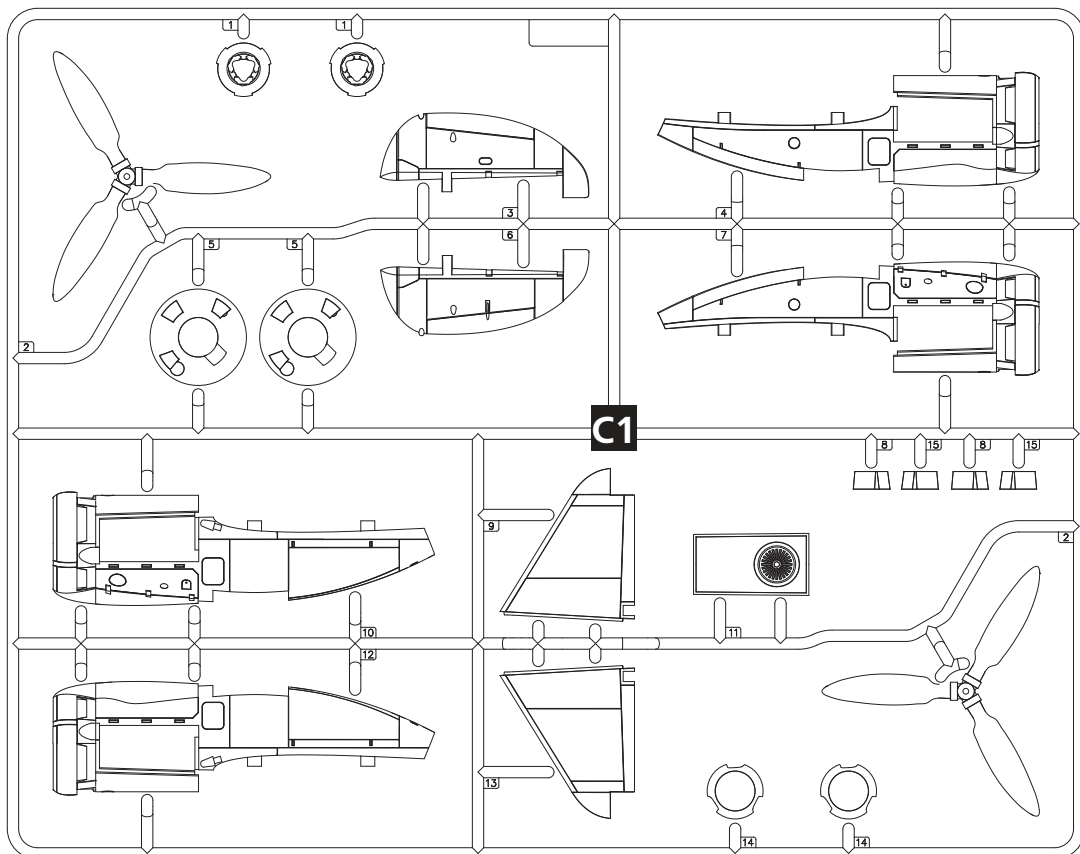
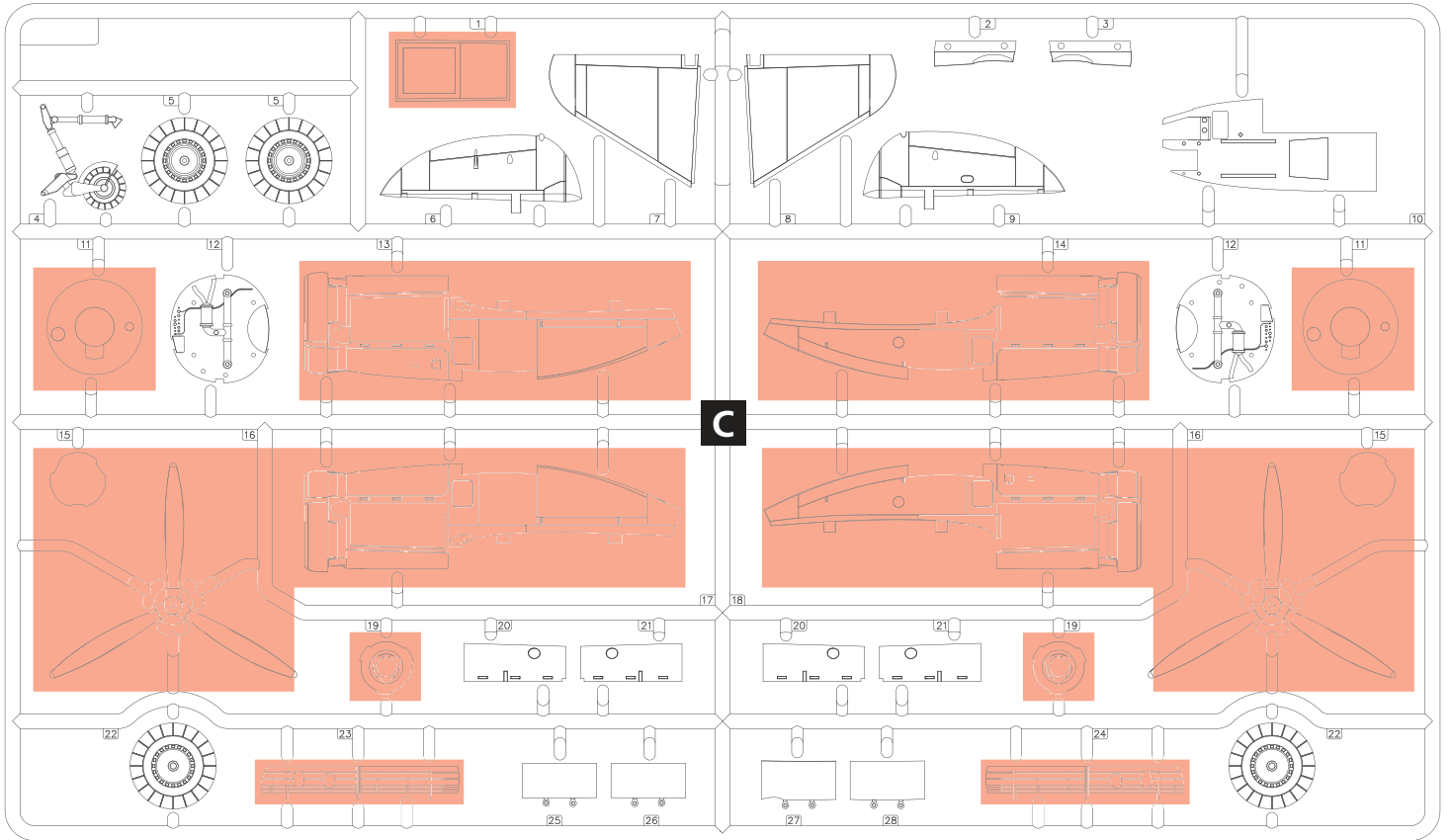

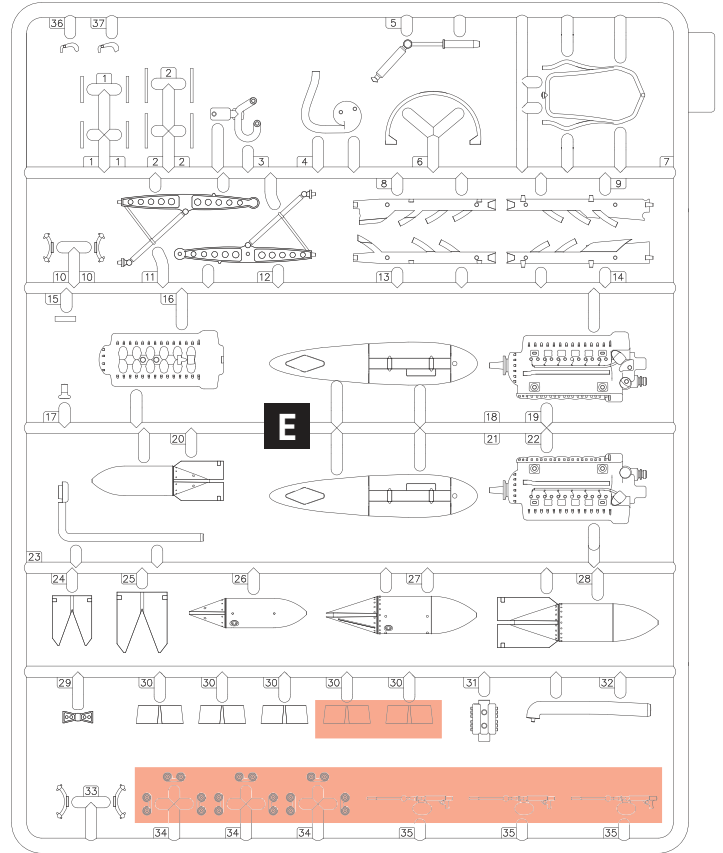
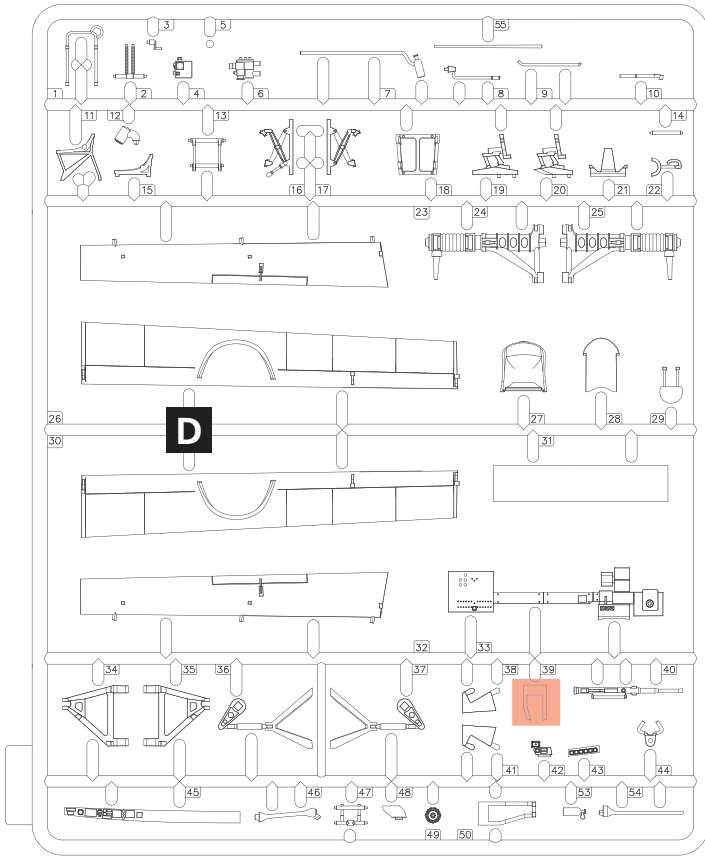

x2

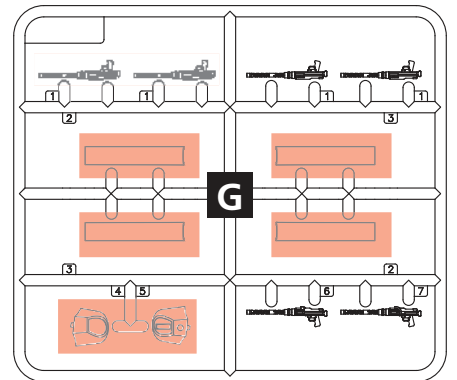
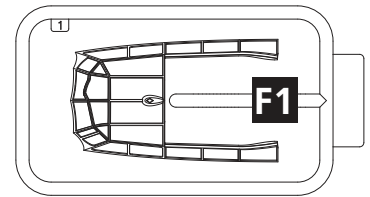
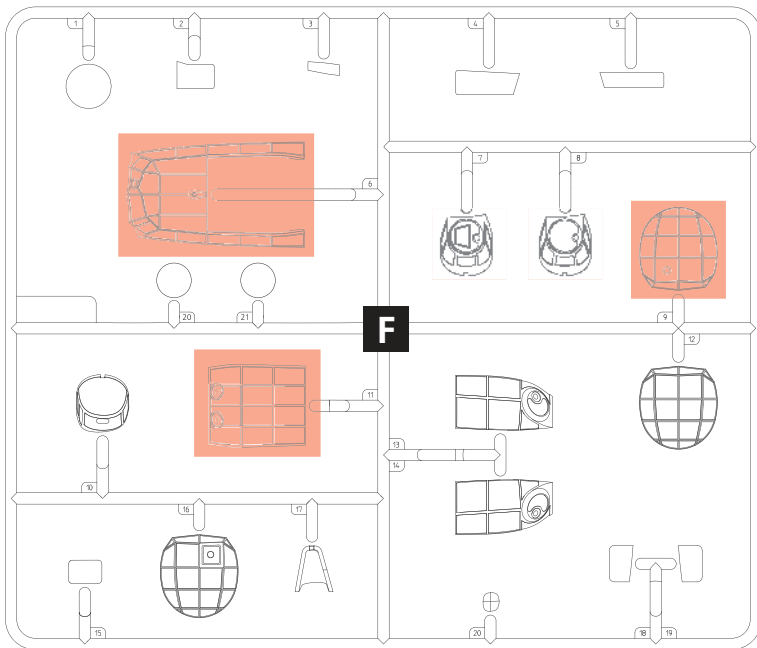

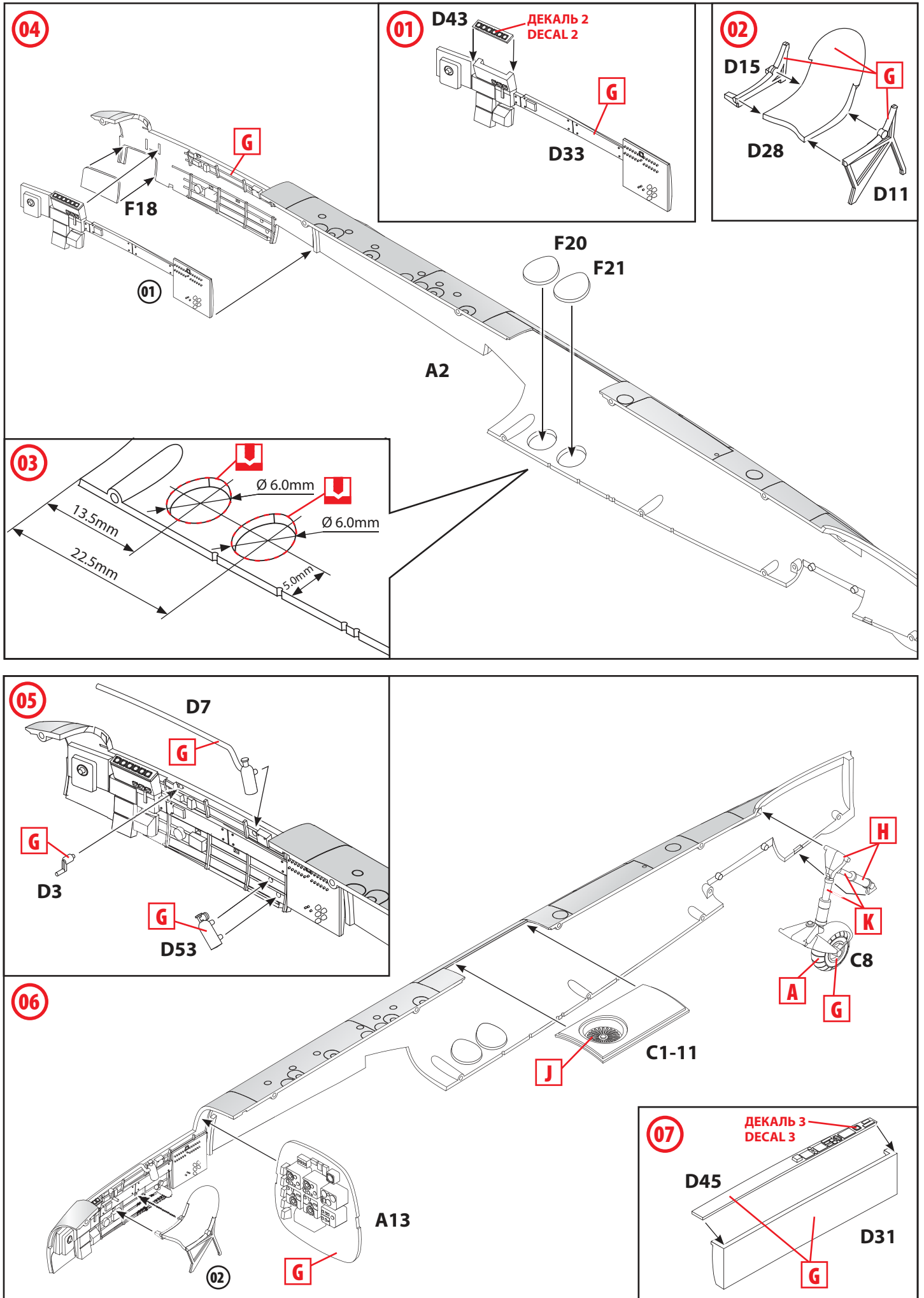

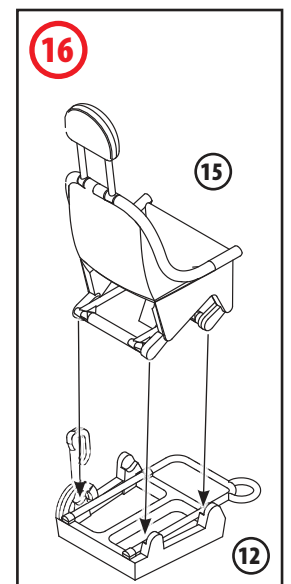
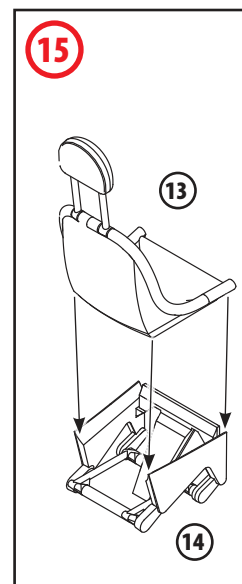
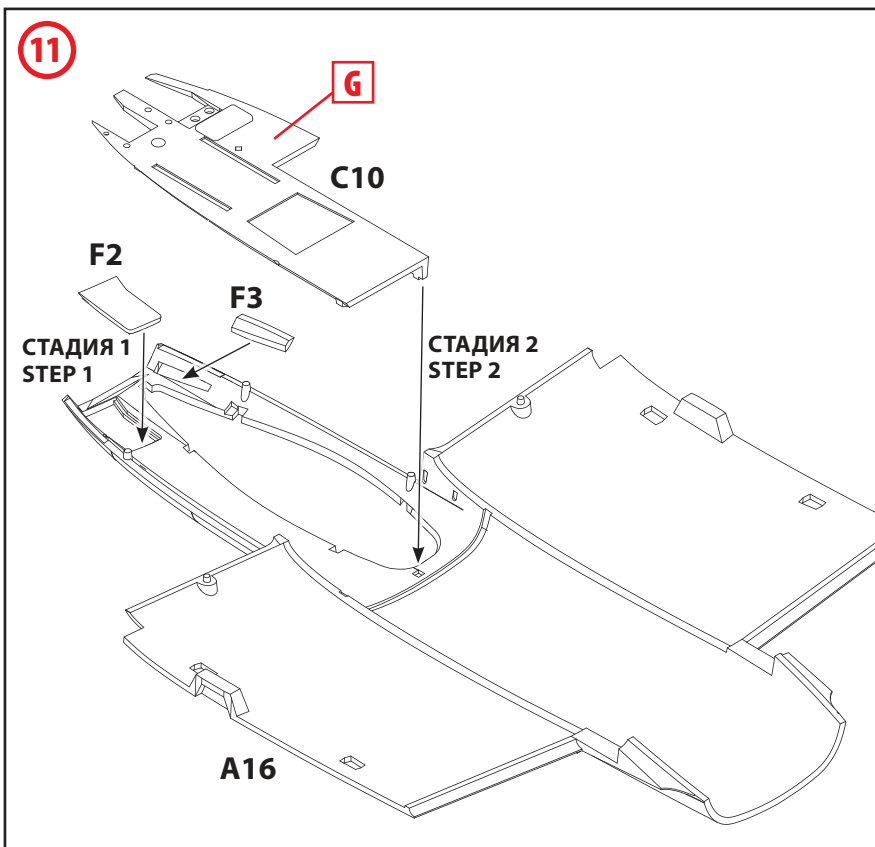
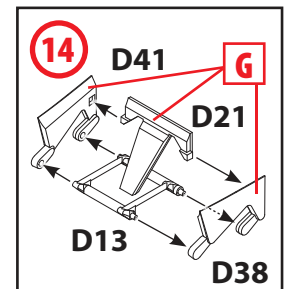
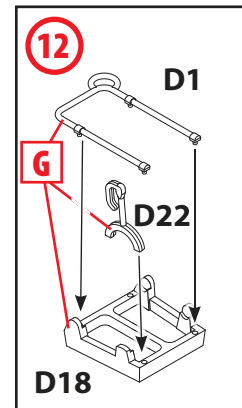
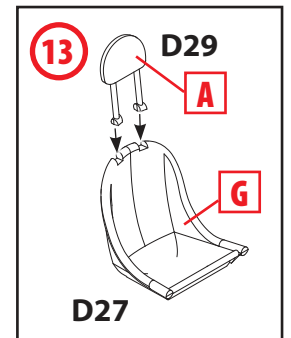
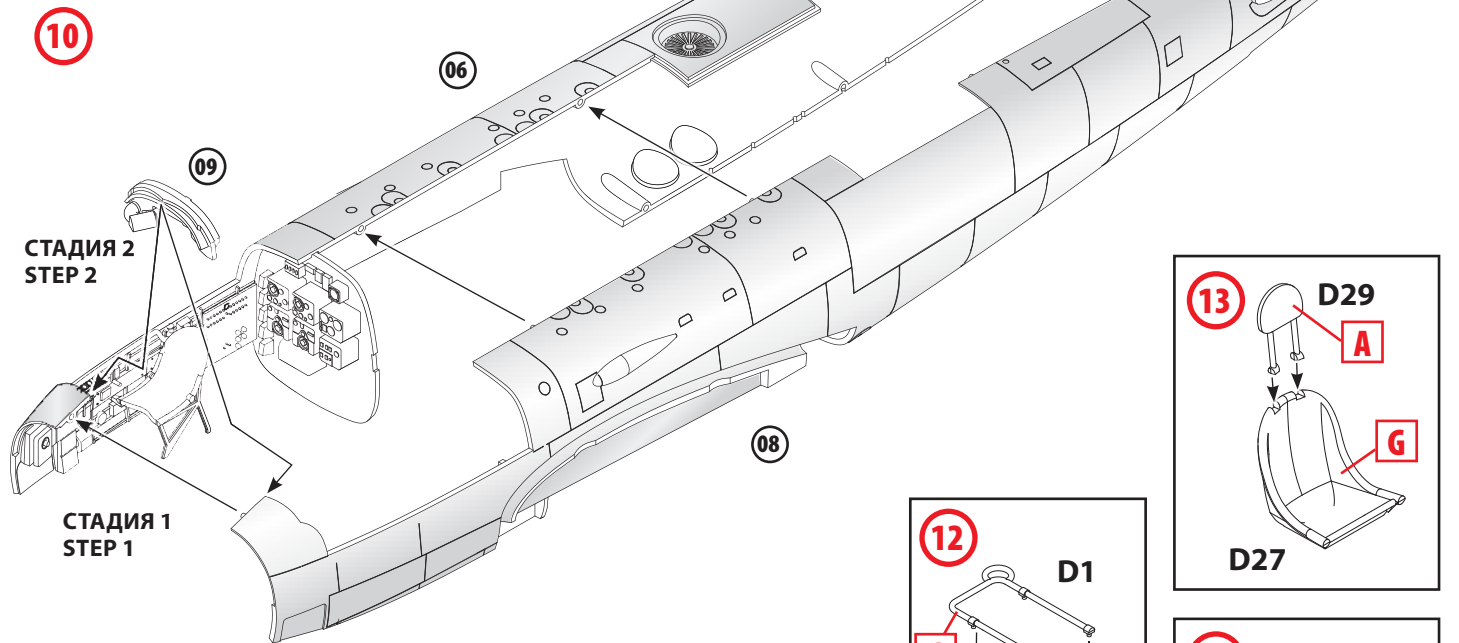
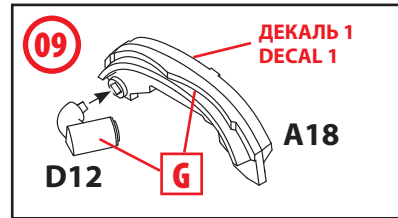
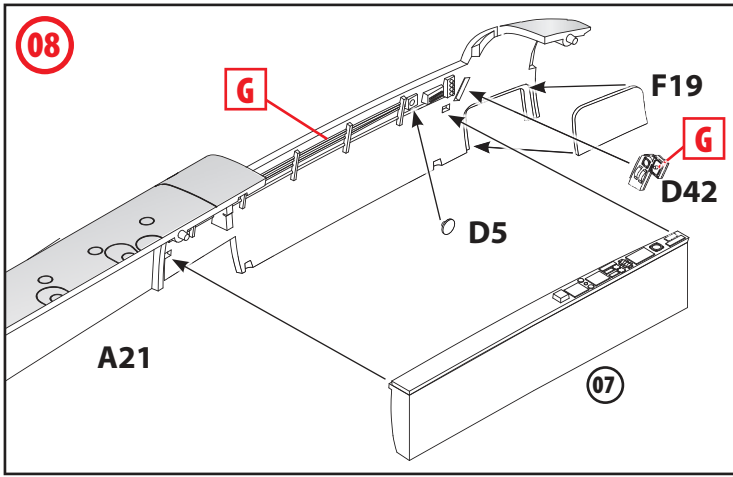

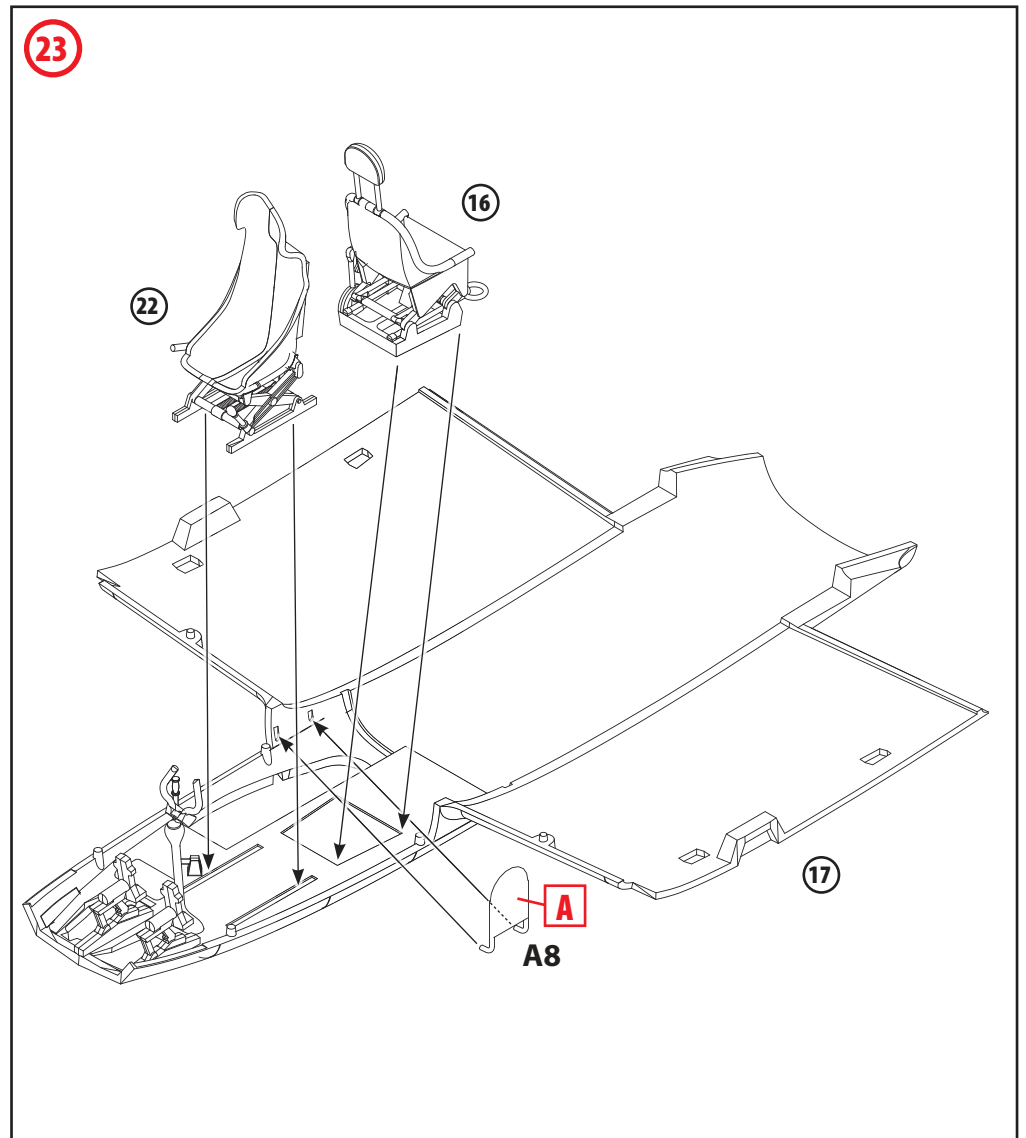
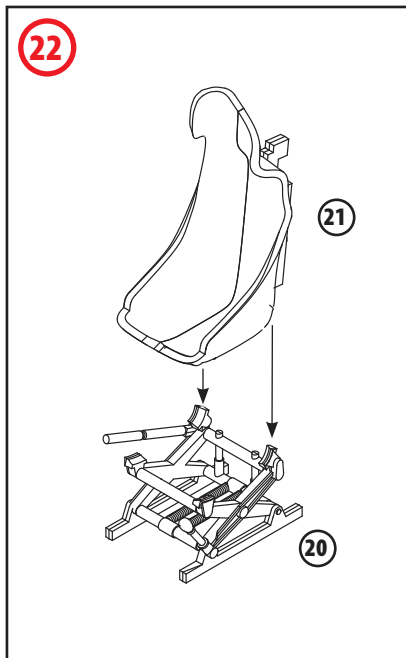
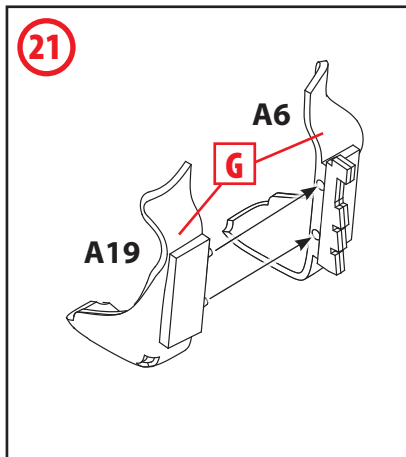
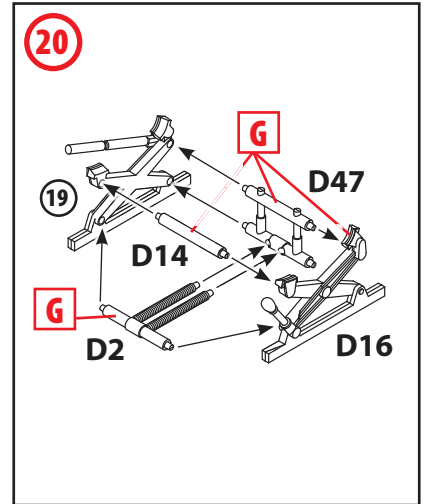
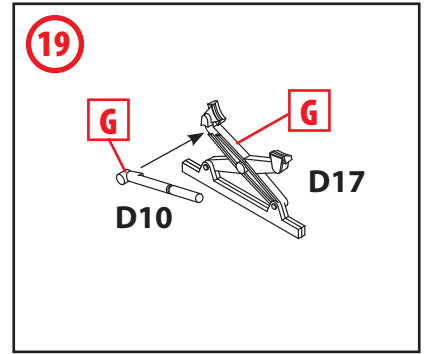
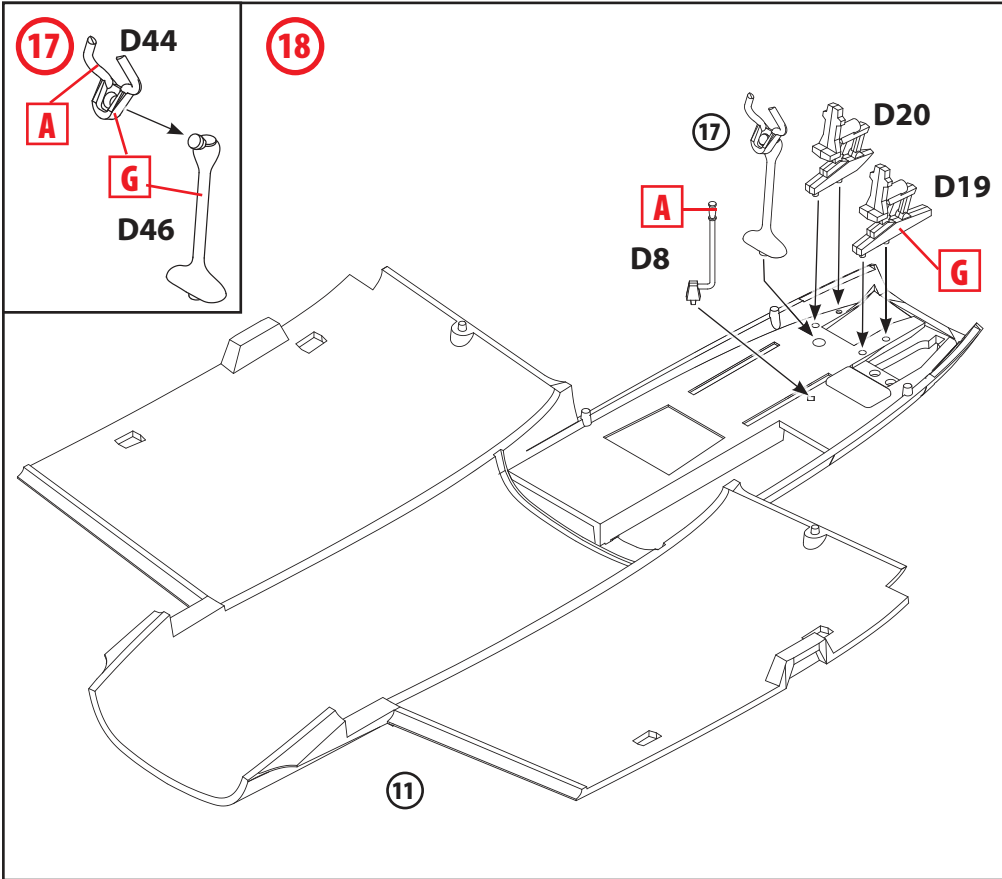

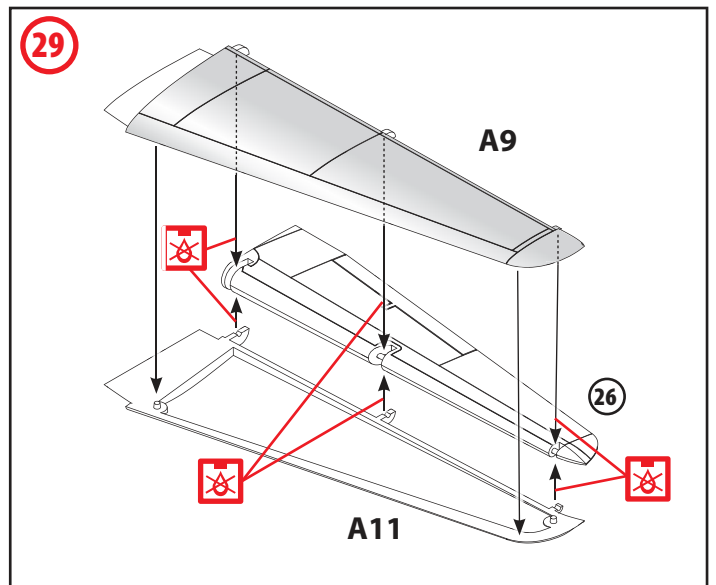
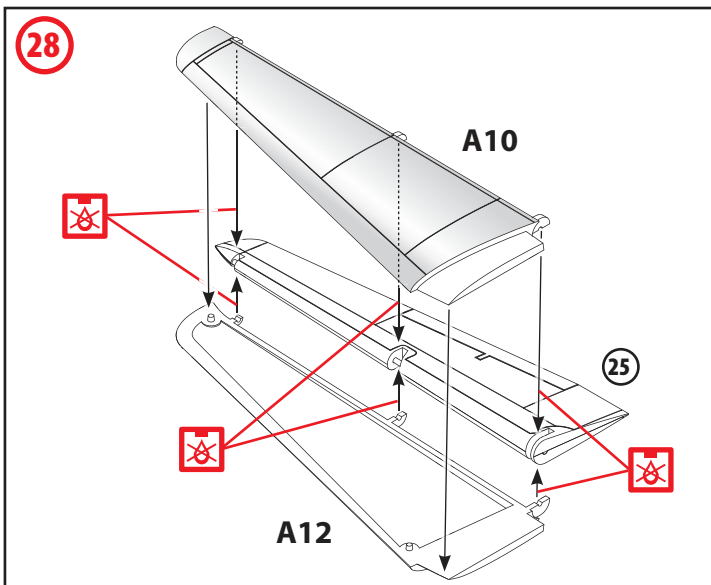
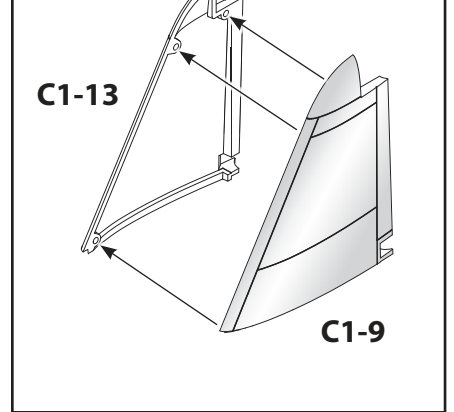
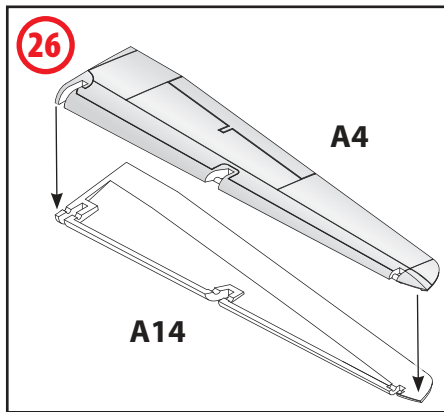
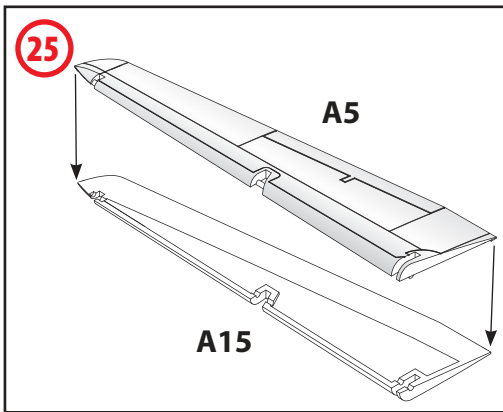
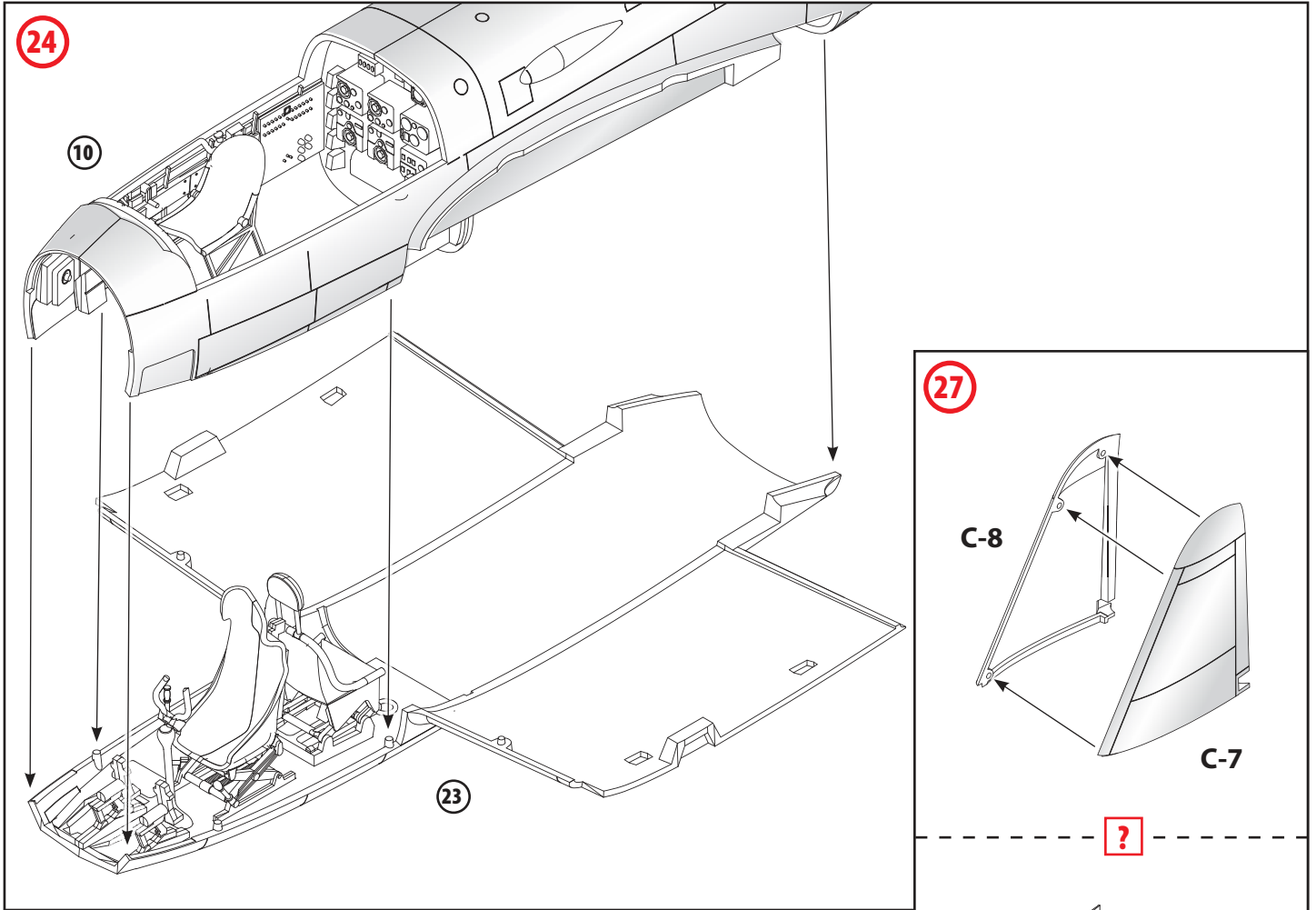

30

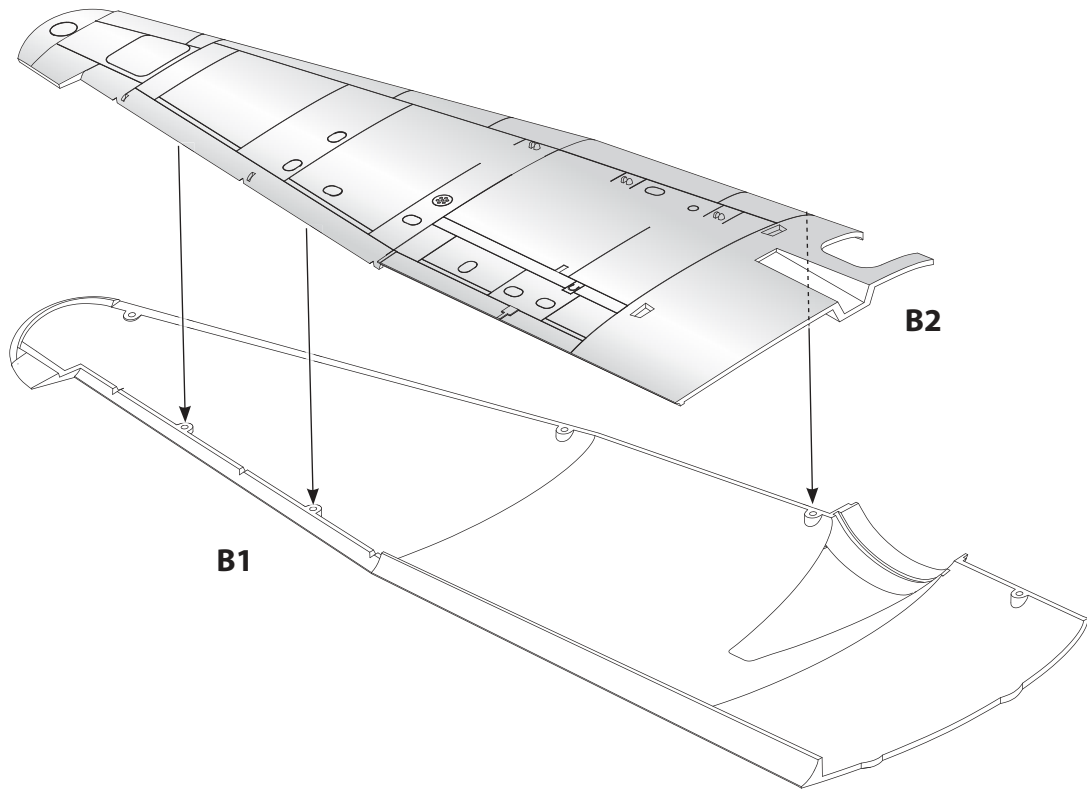

31

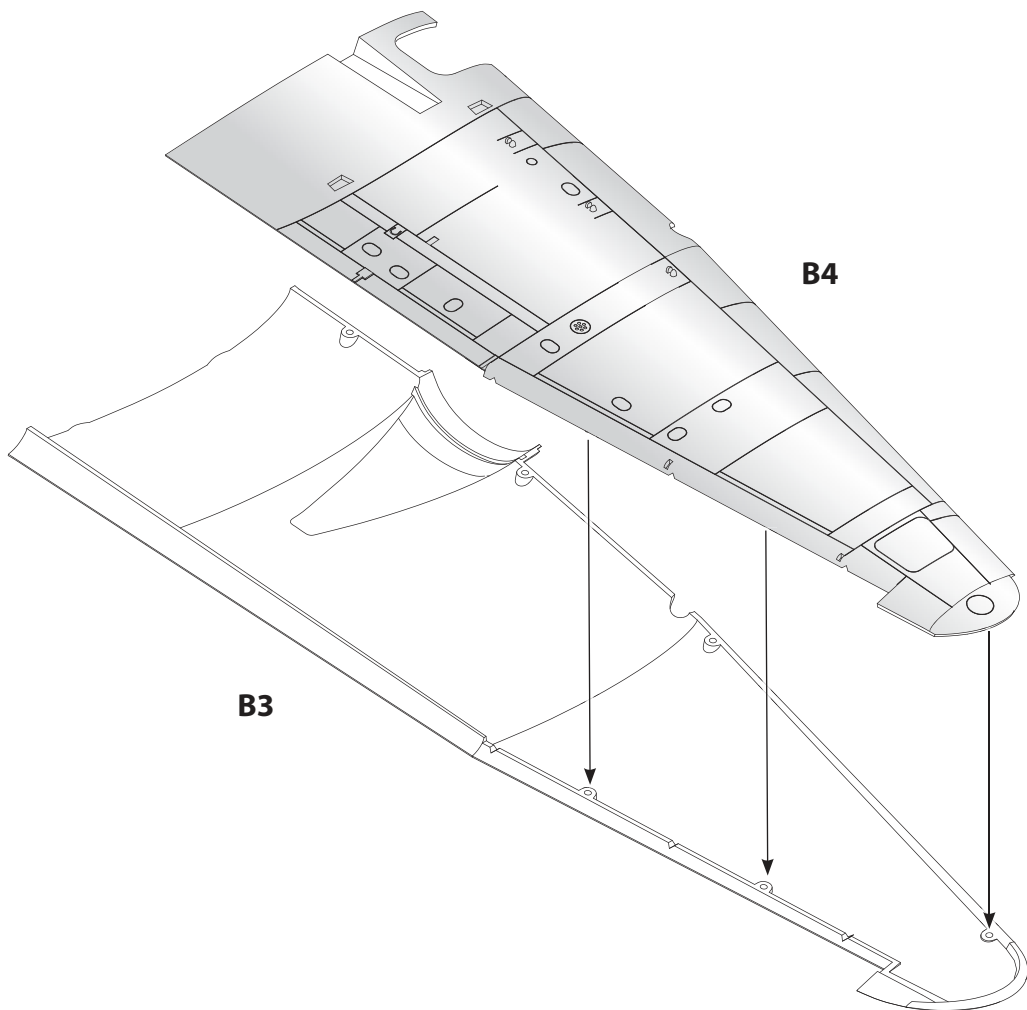

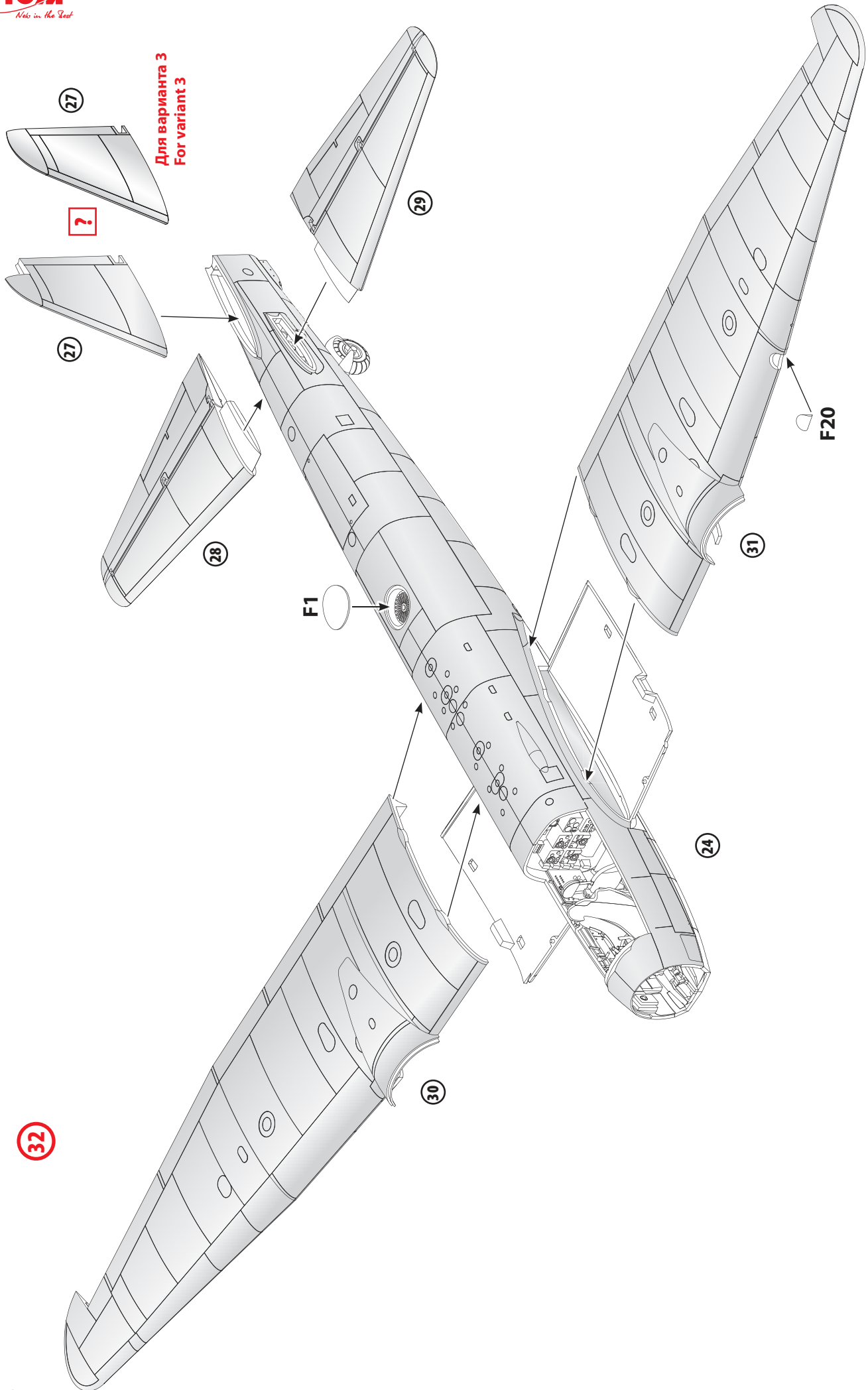

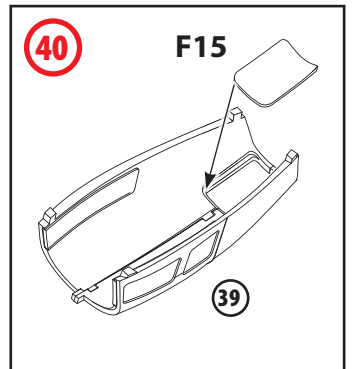
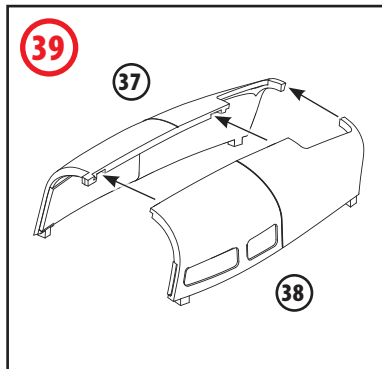
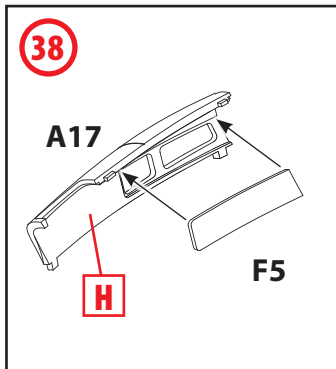
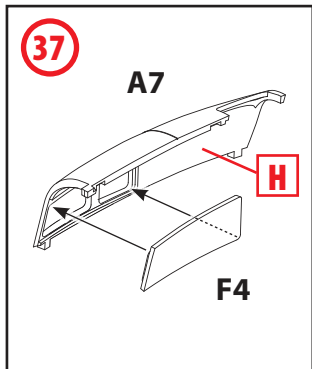
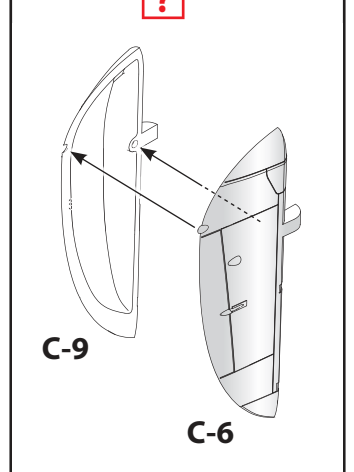
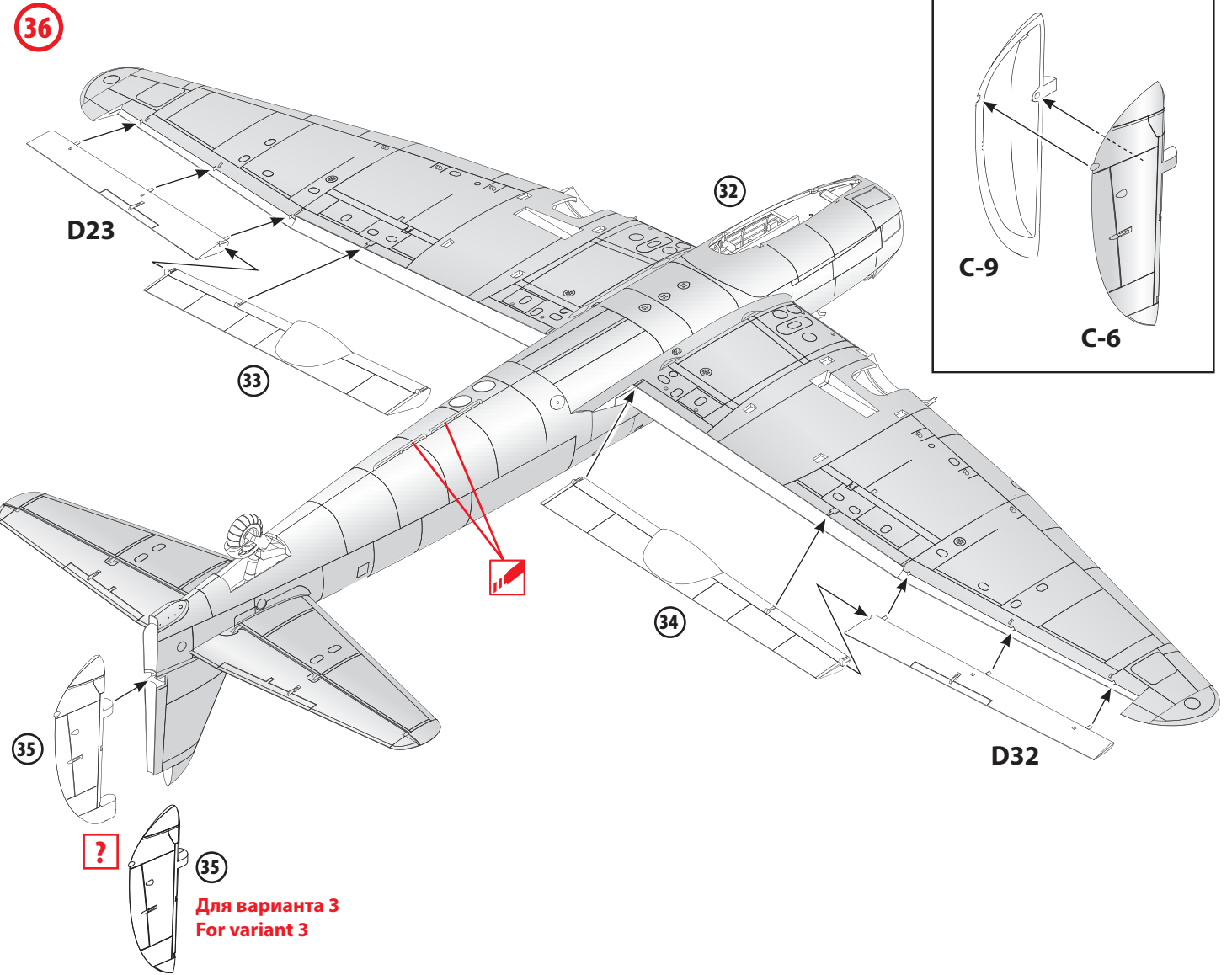
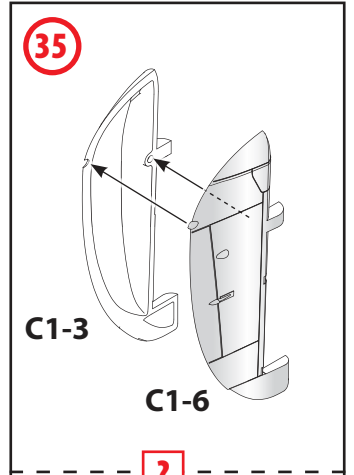
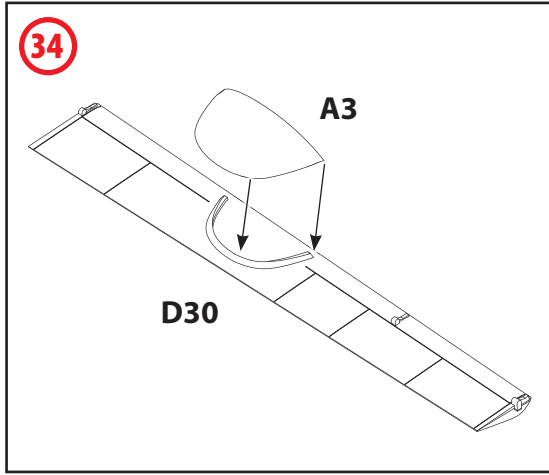
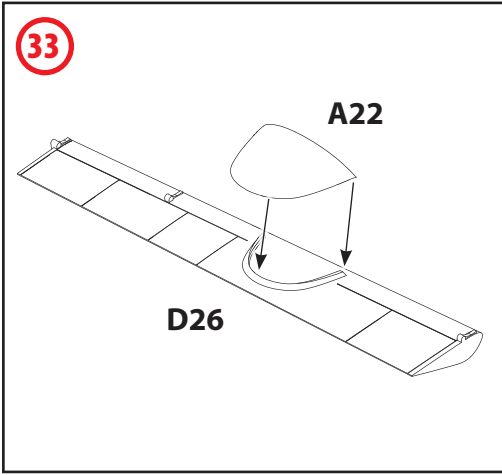

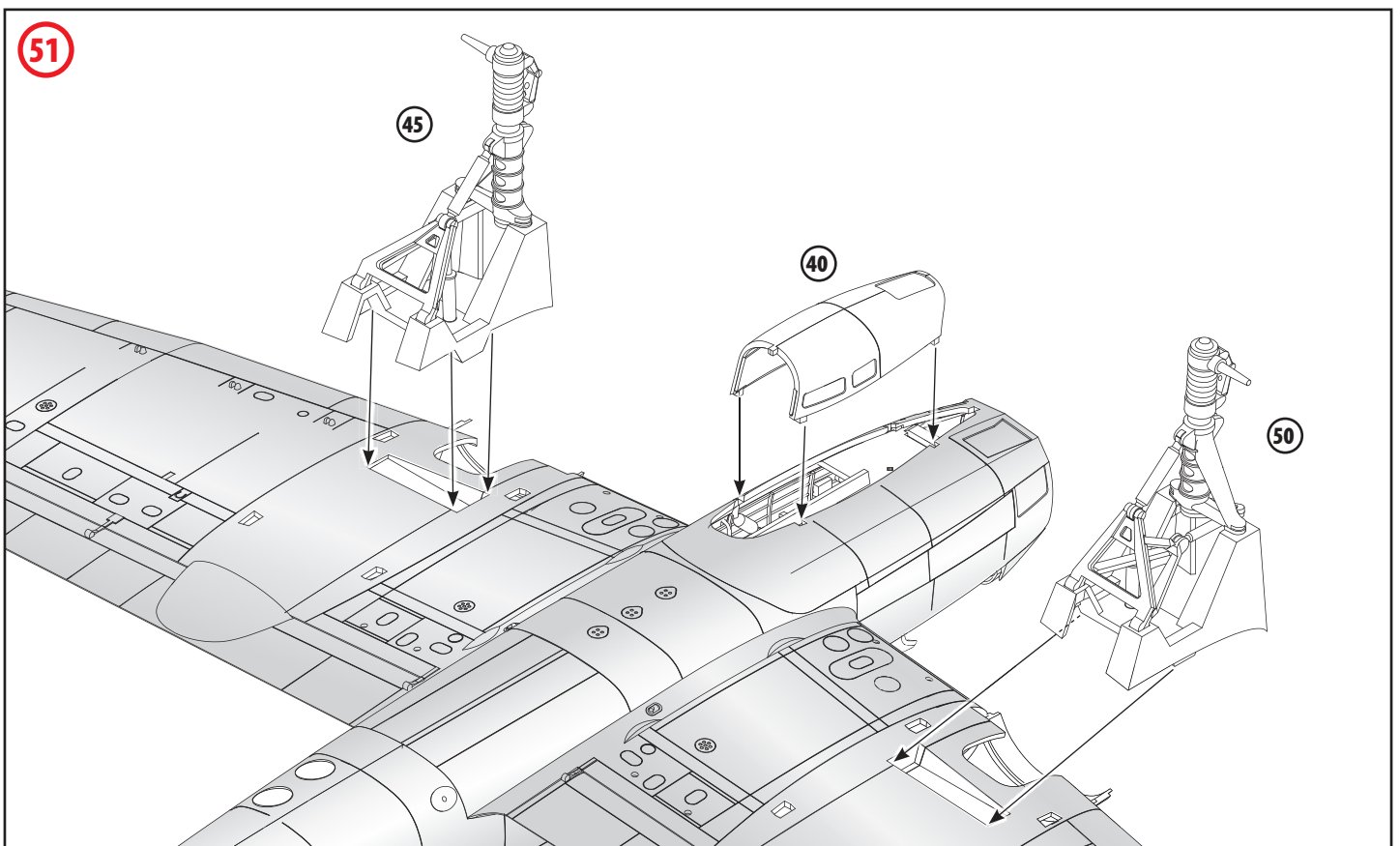
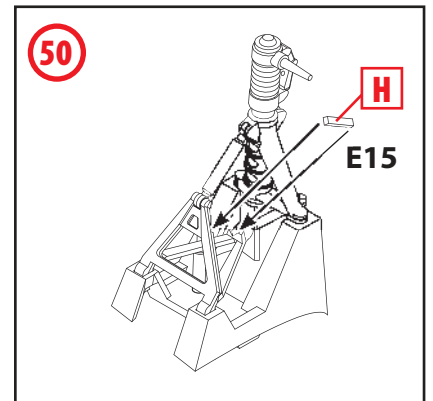
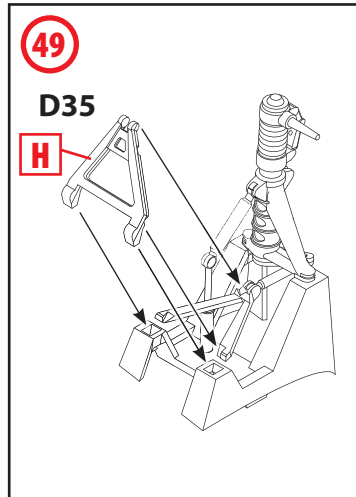
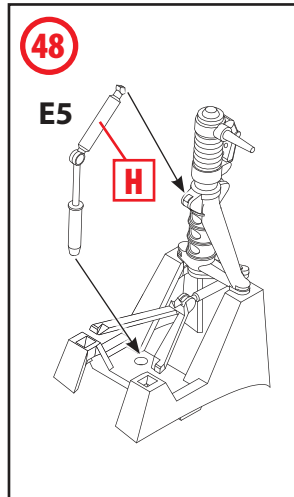
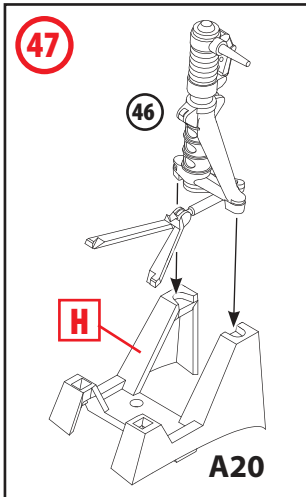
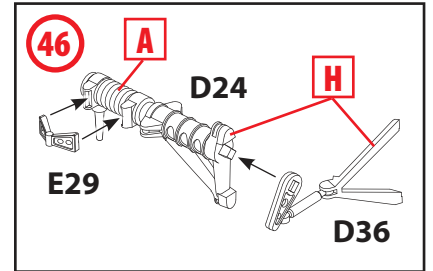
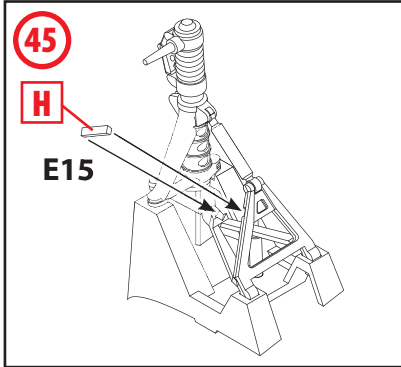
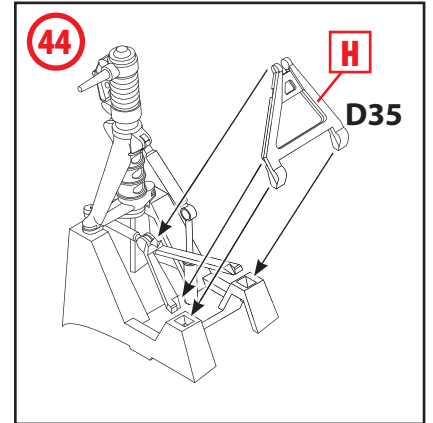
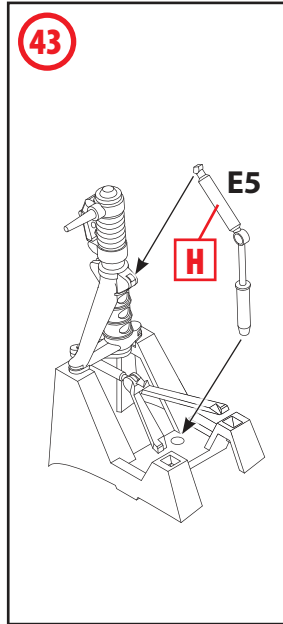
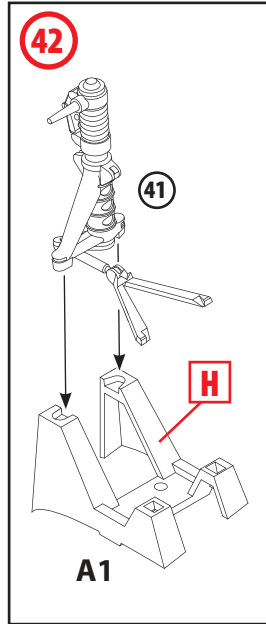
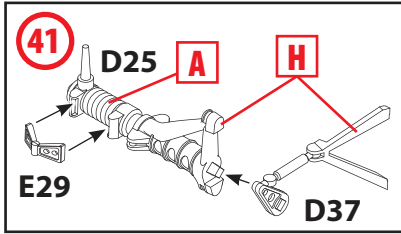

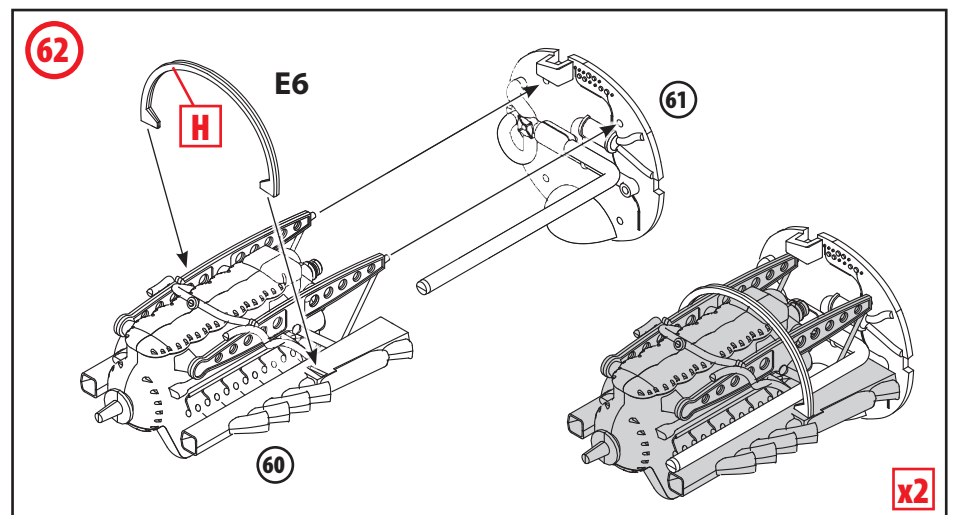
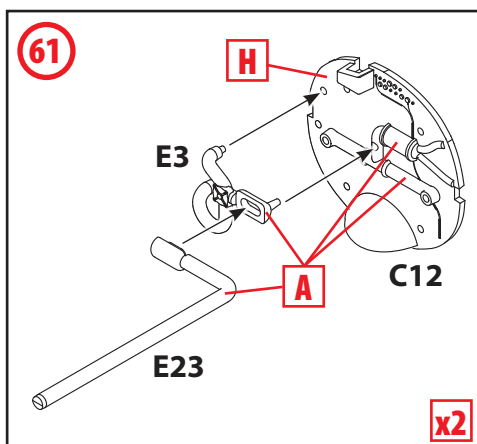
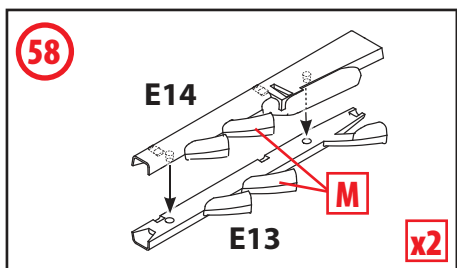
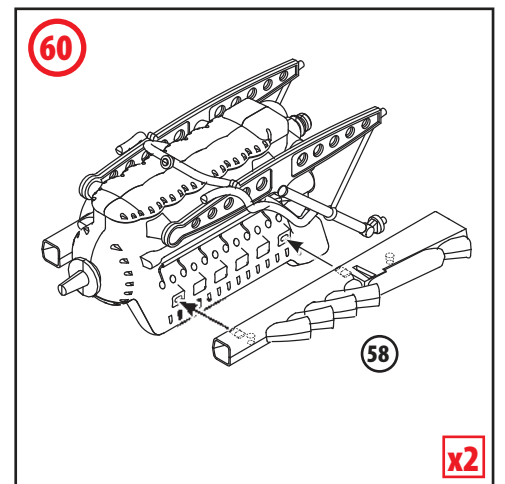
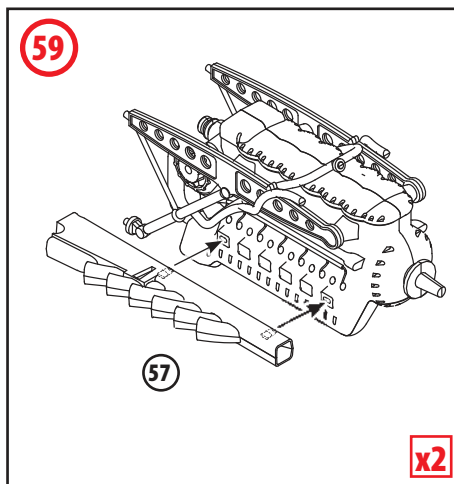
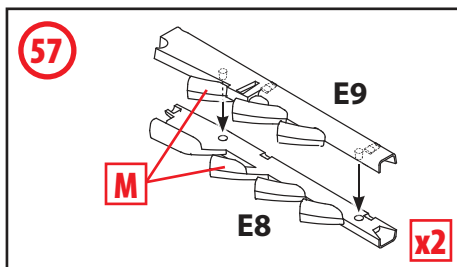
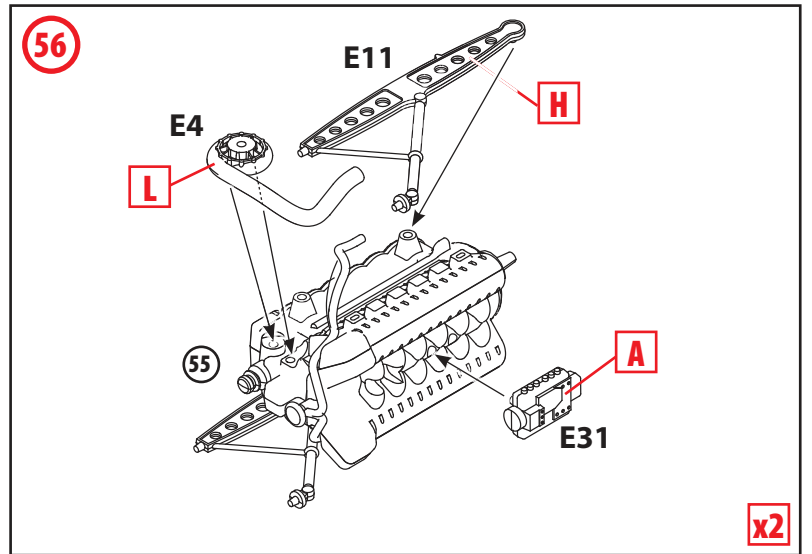
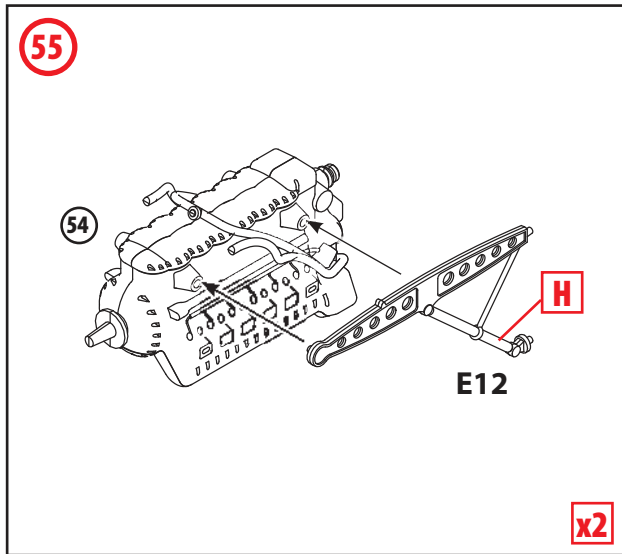
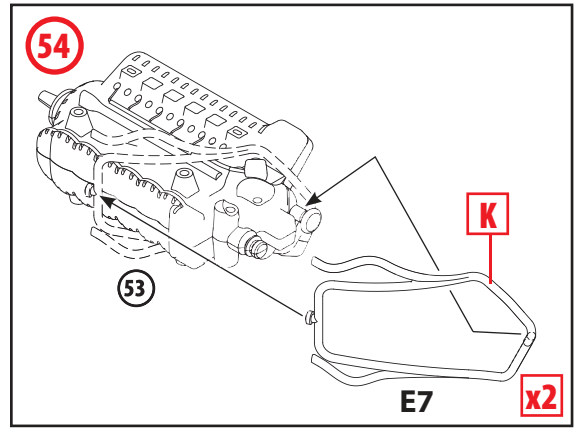
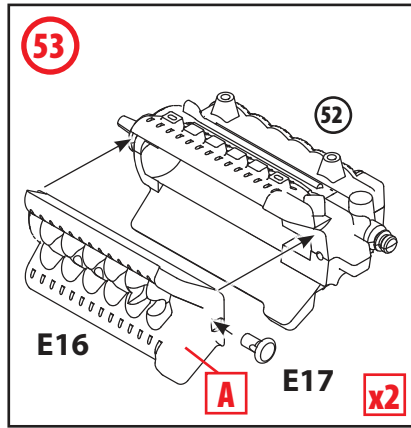
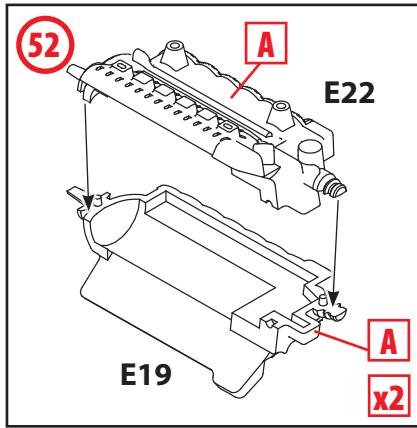

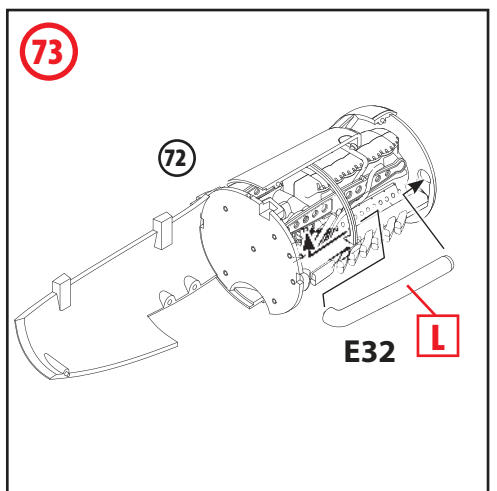
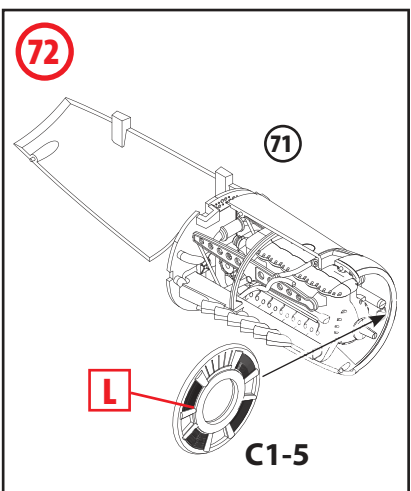
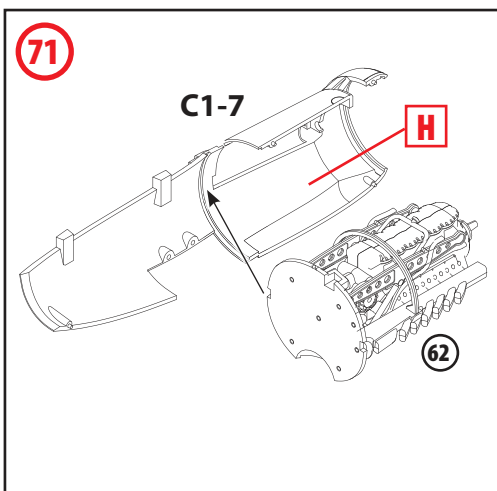
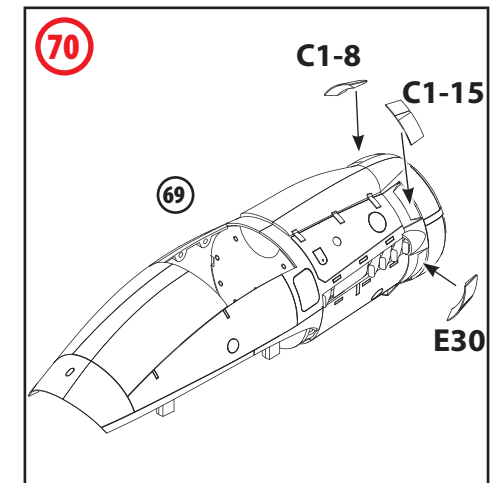
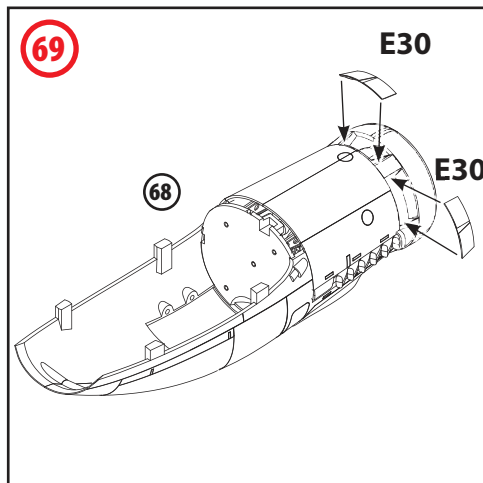
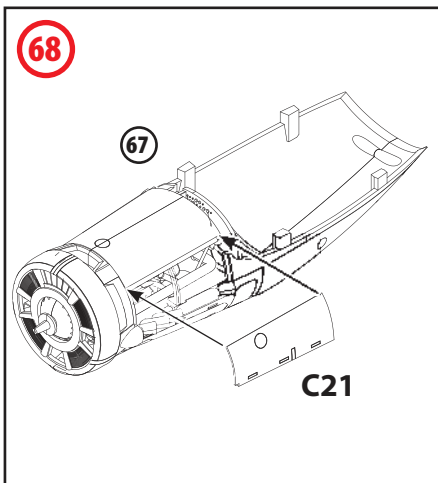
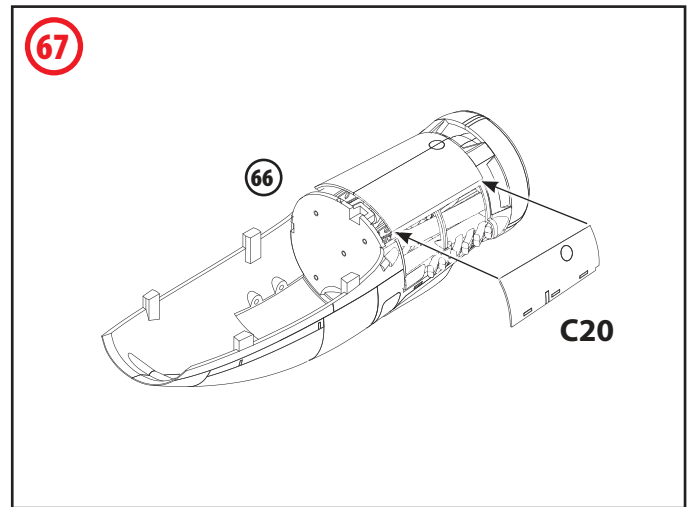
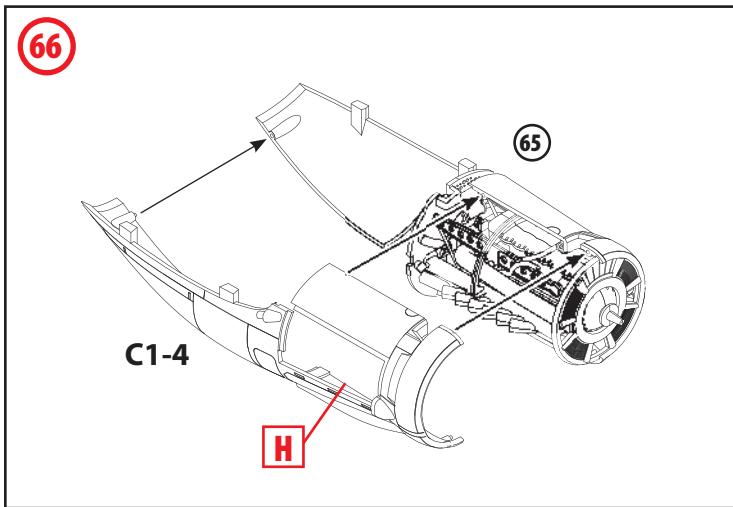
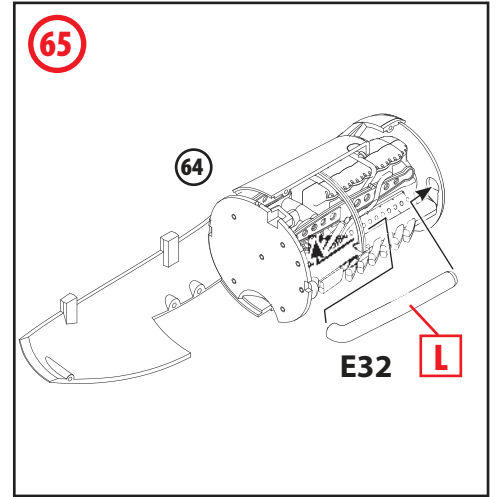
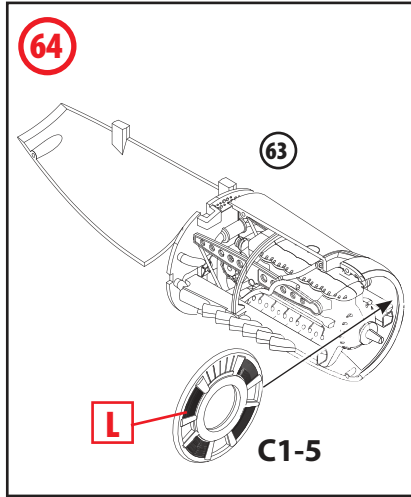
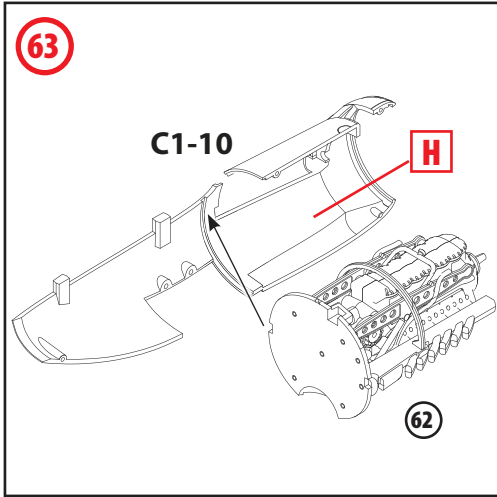

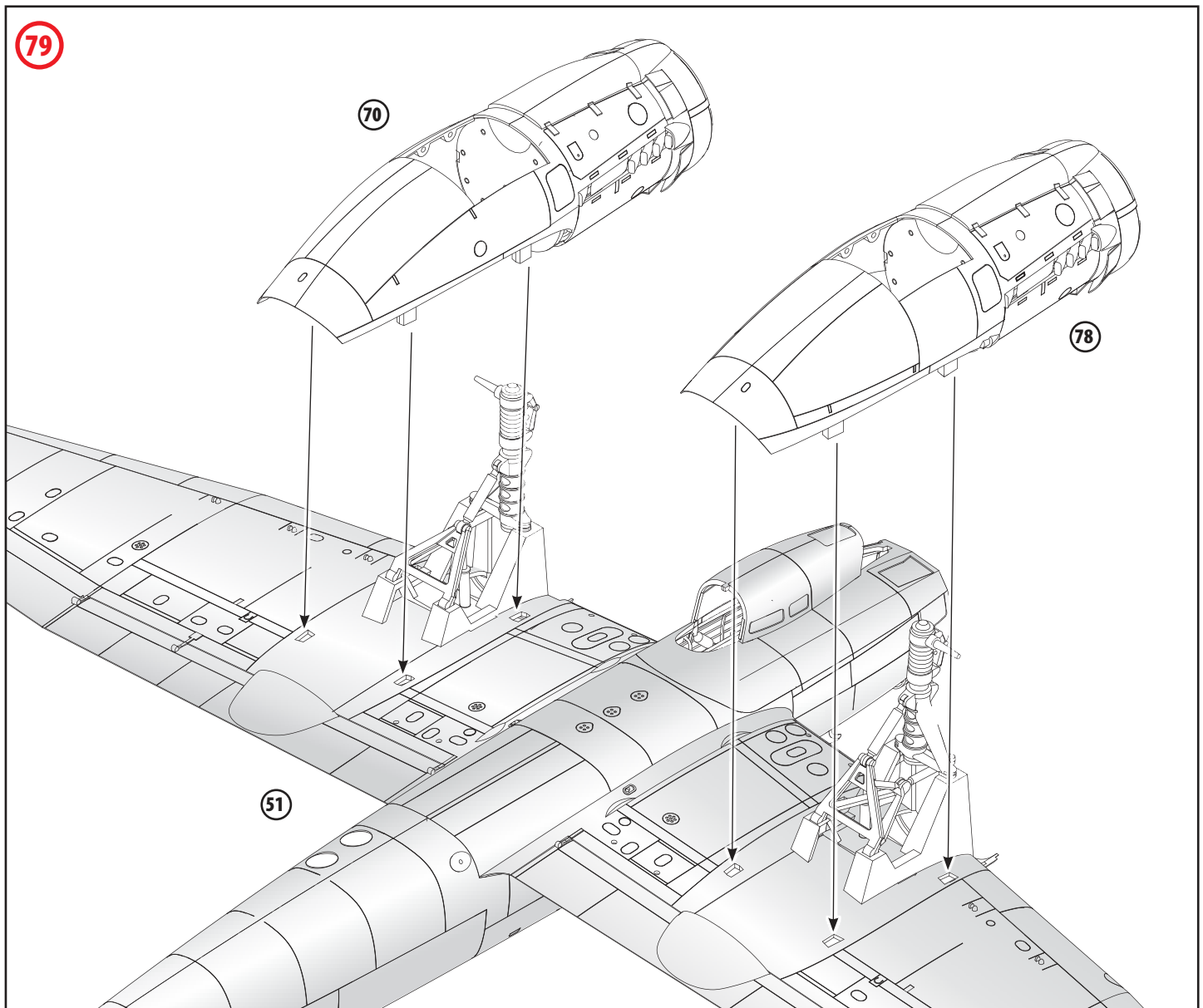
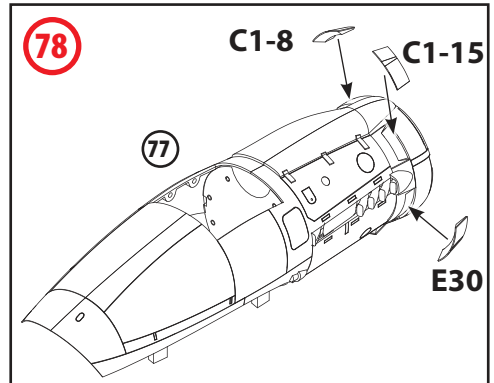
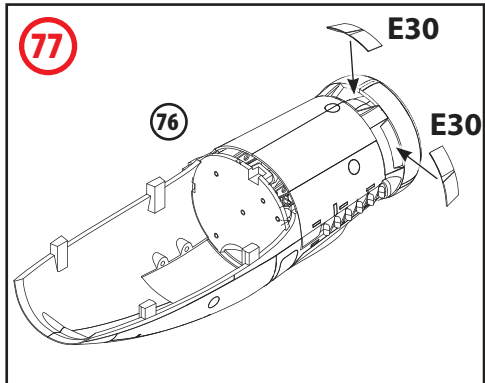
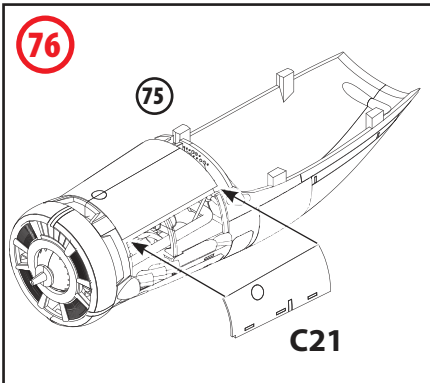
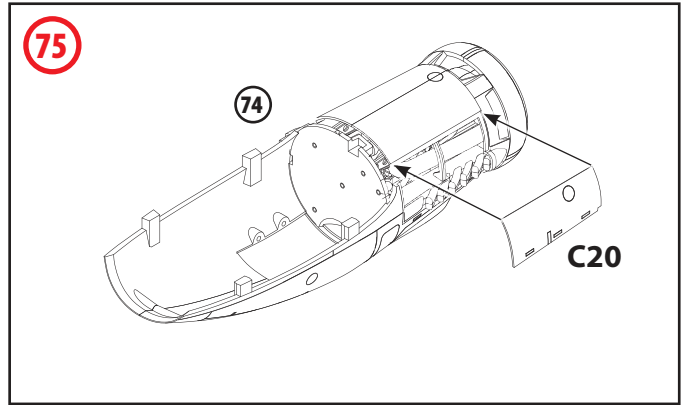
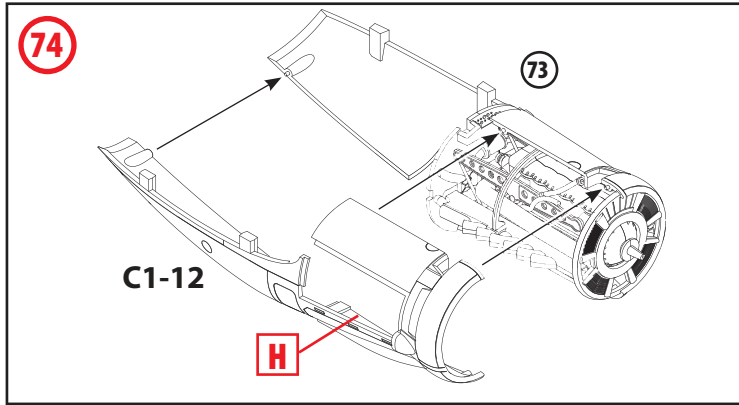

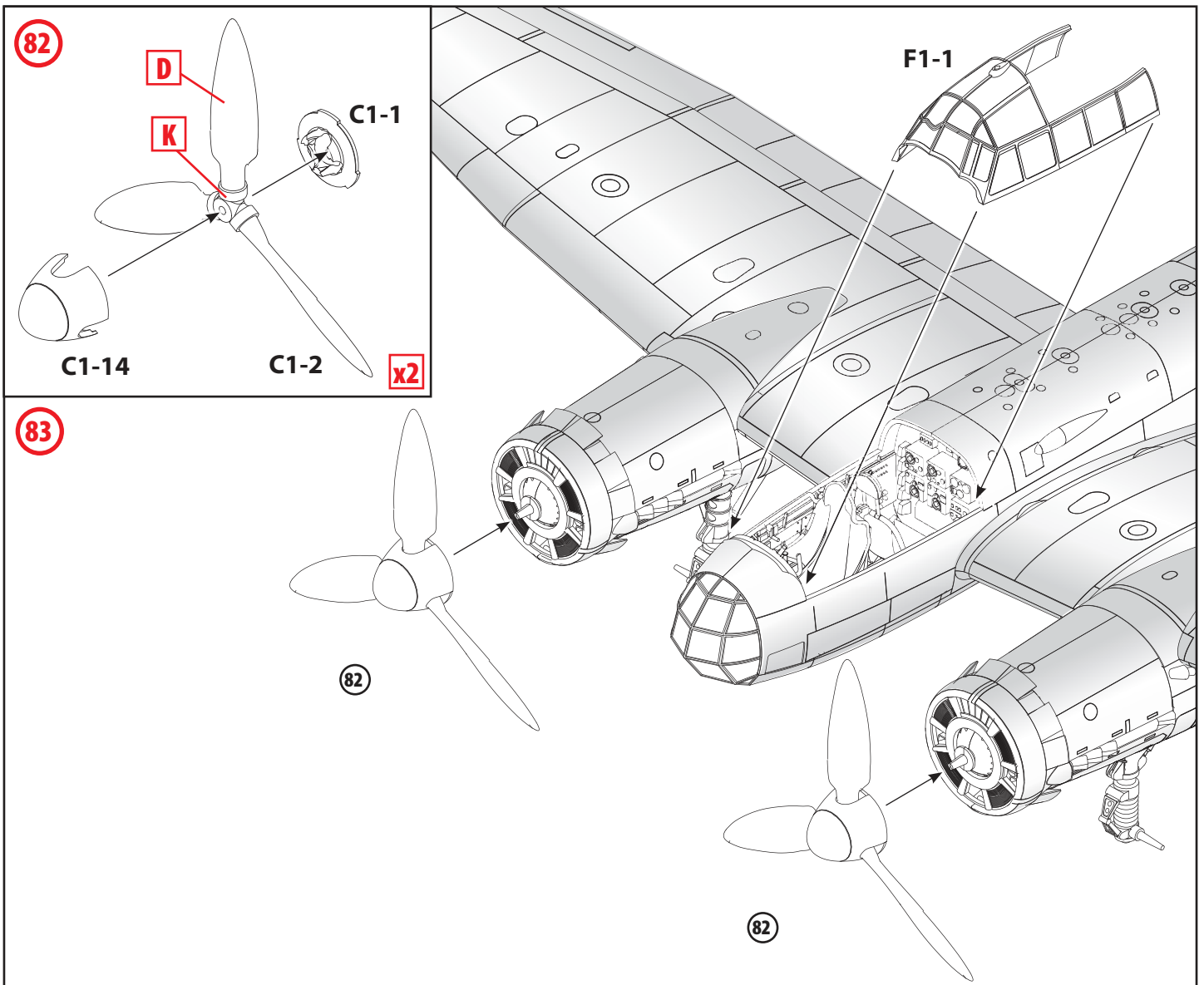
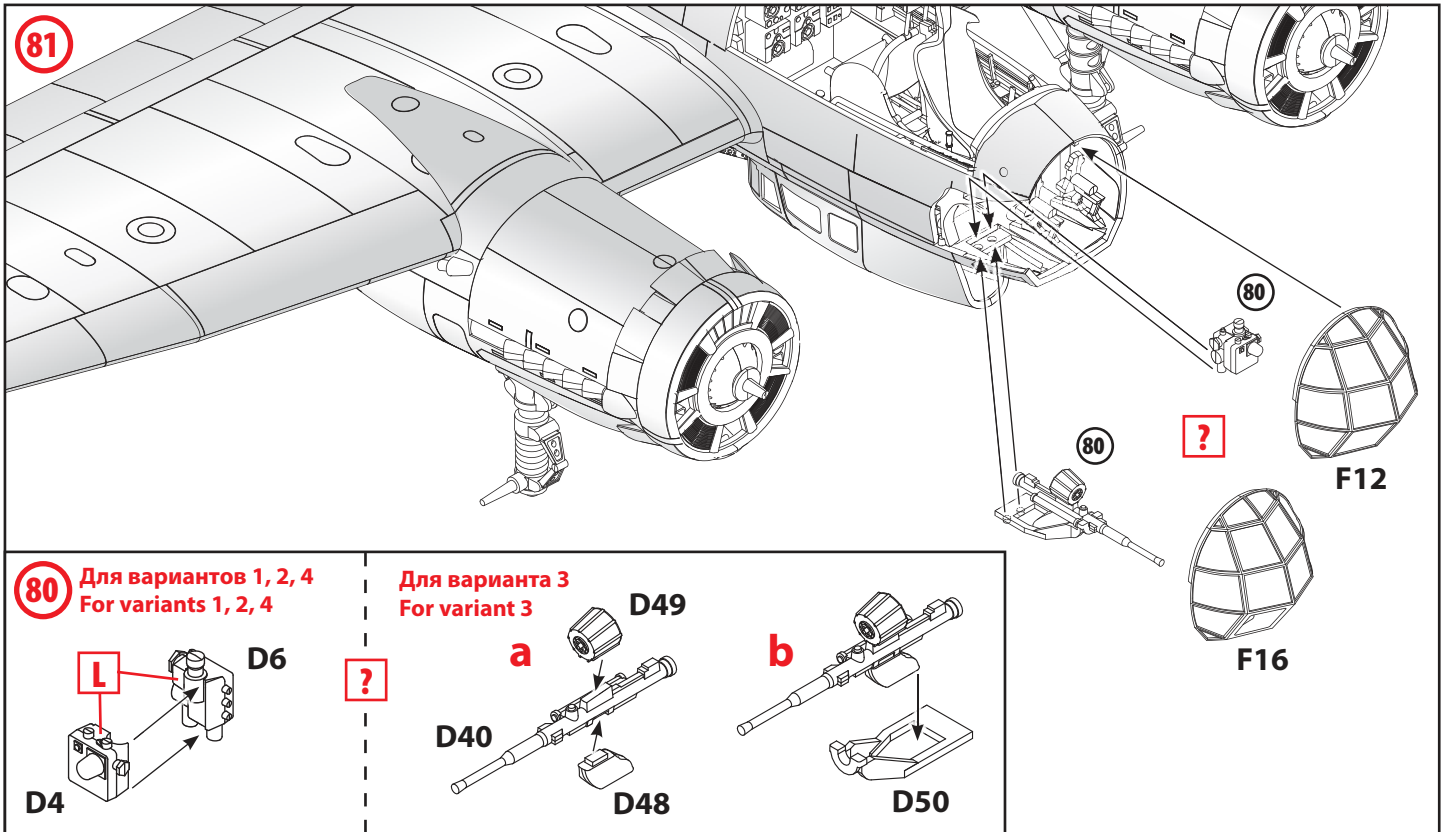

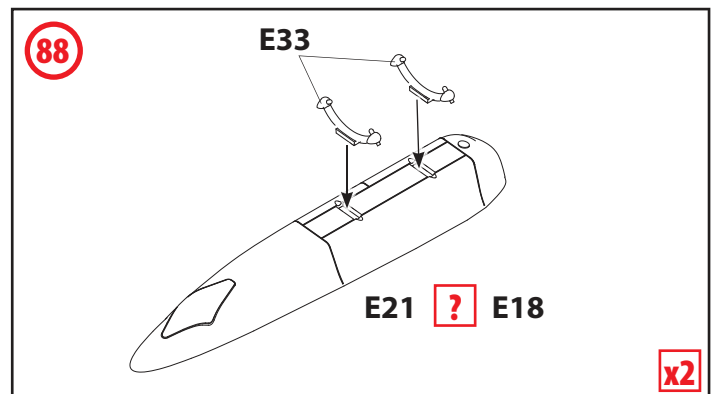
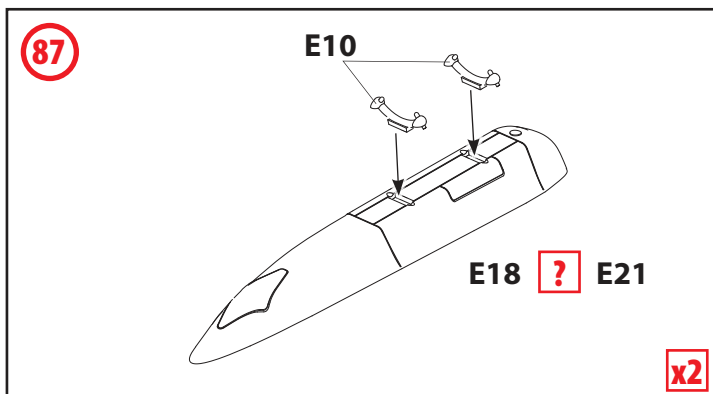
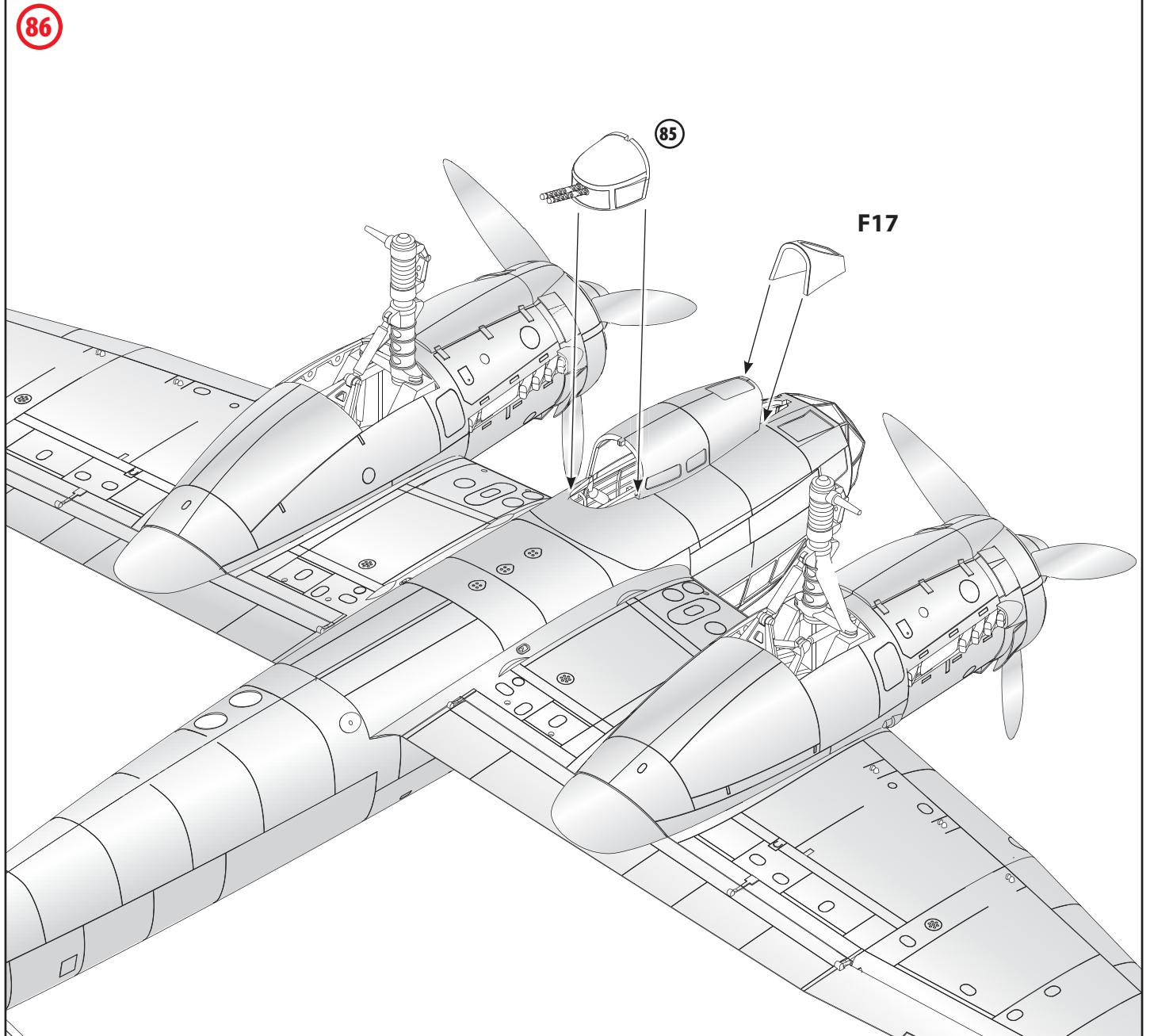
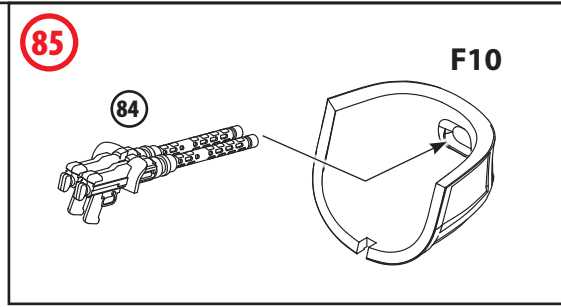
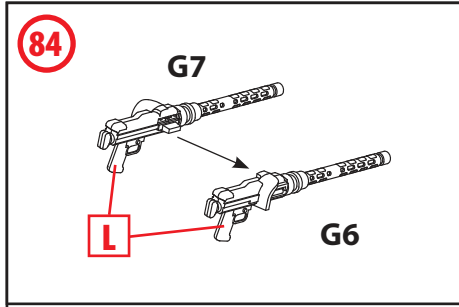

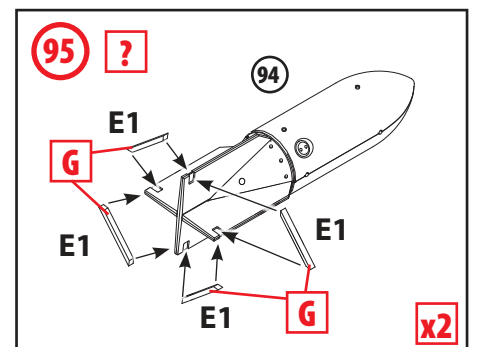
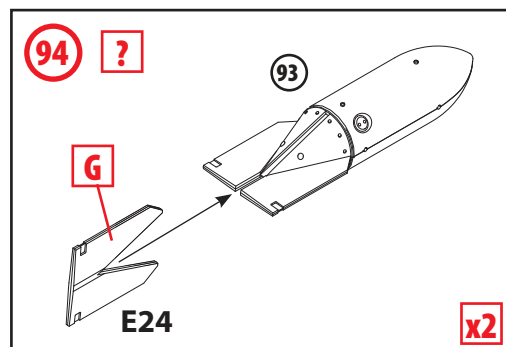
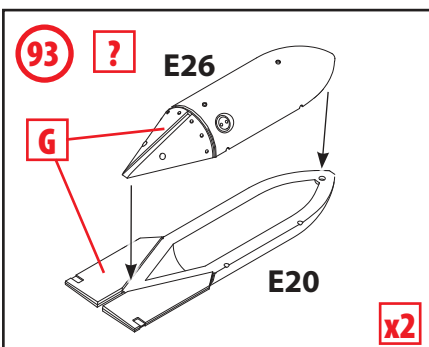
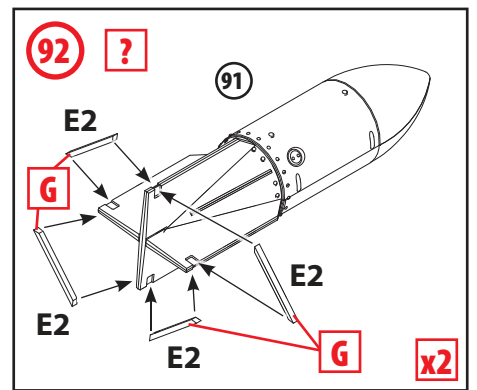
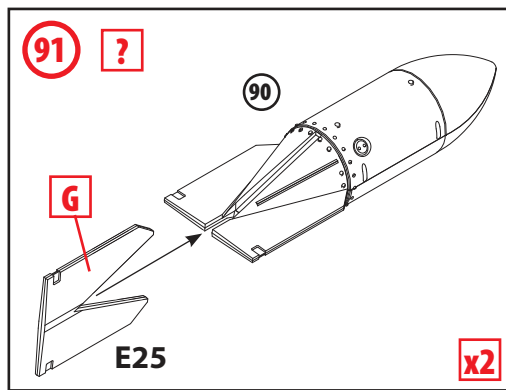
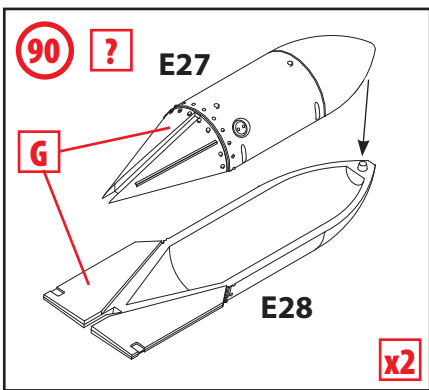
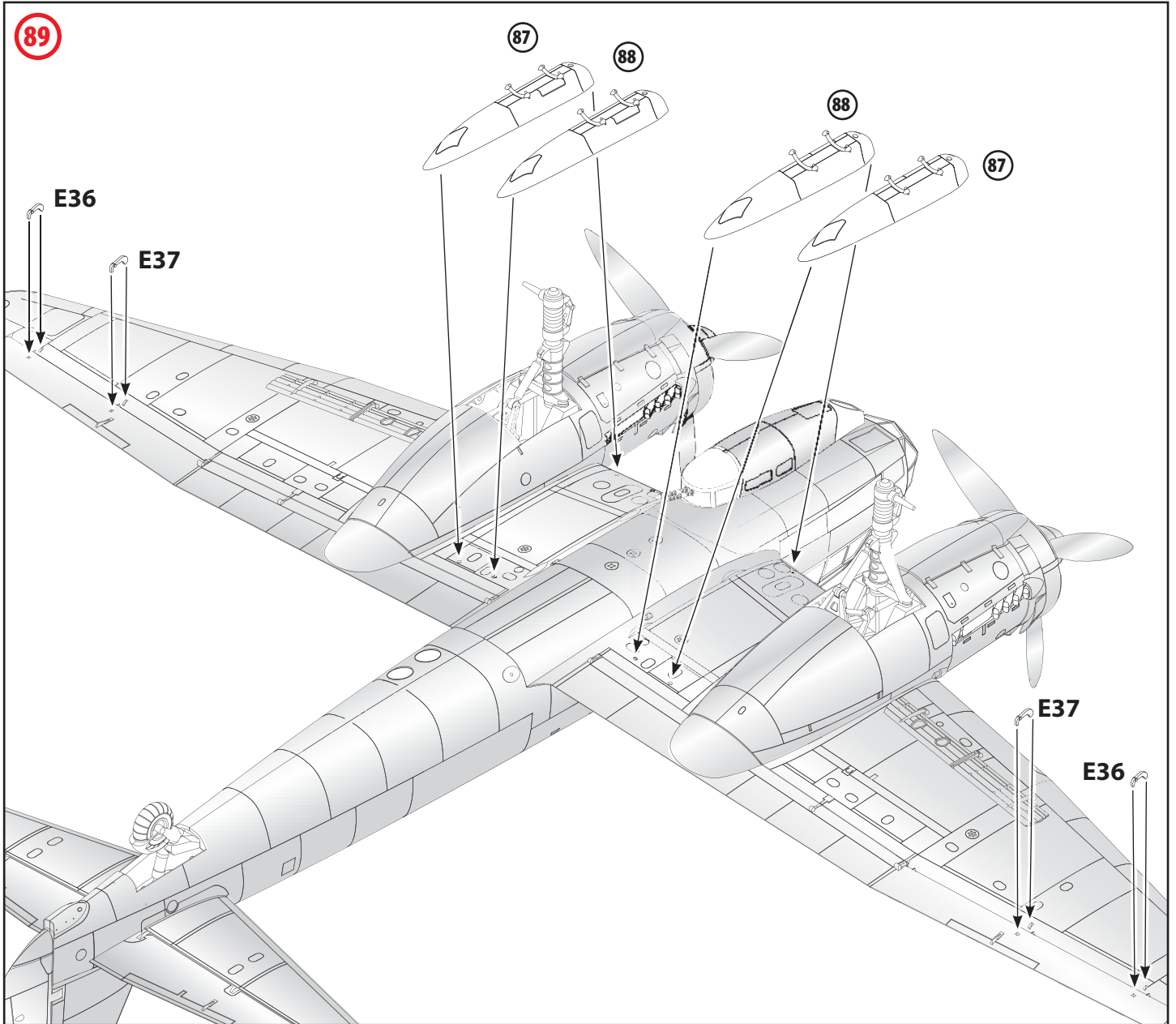

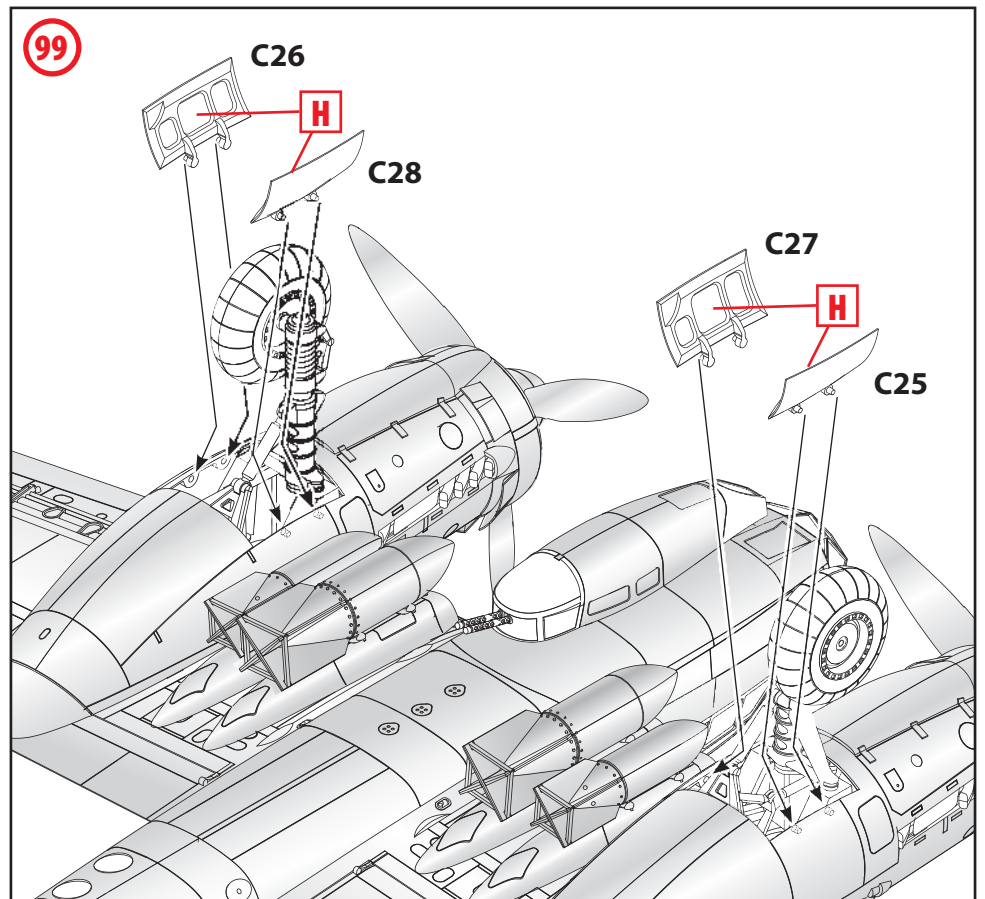
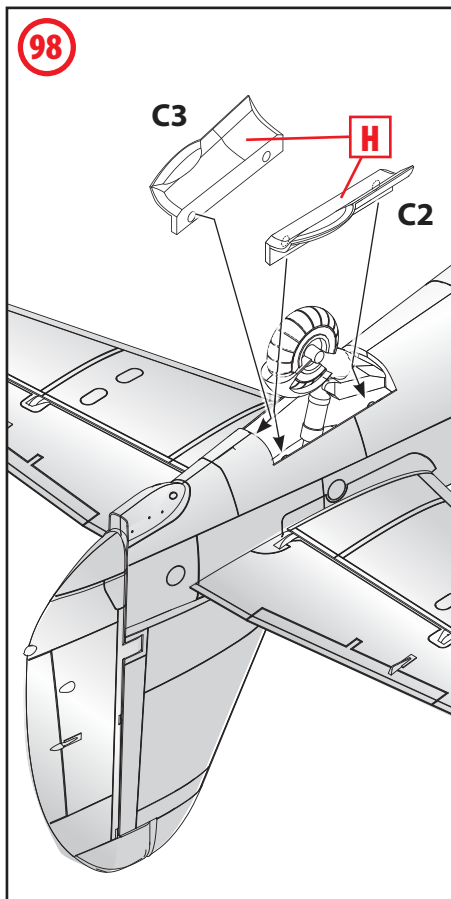
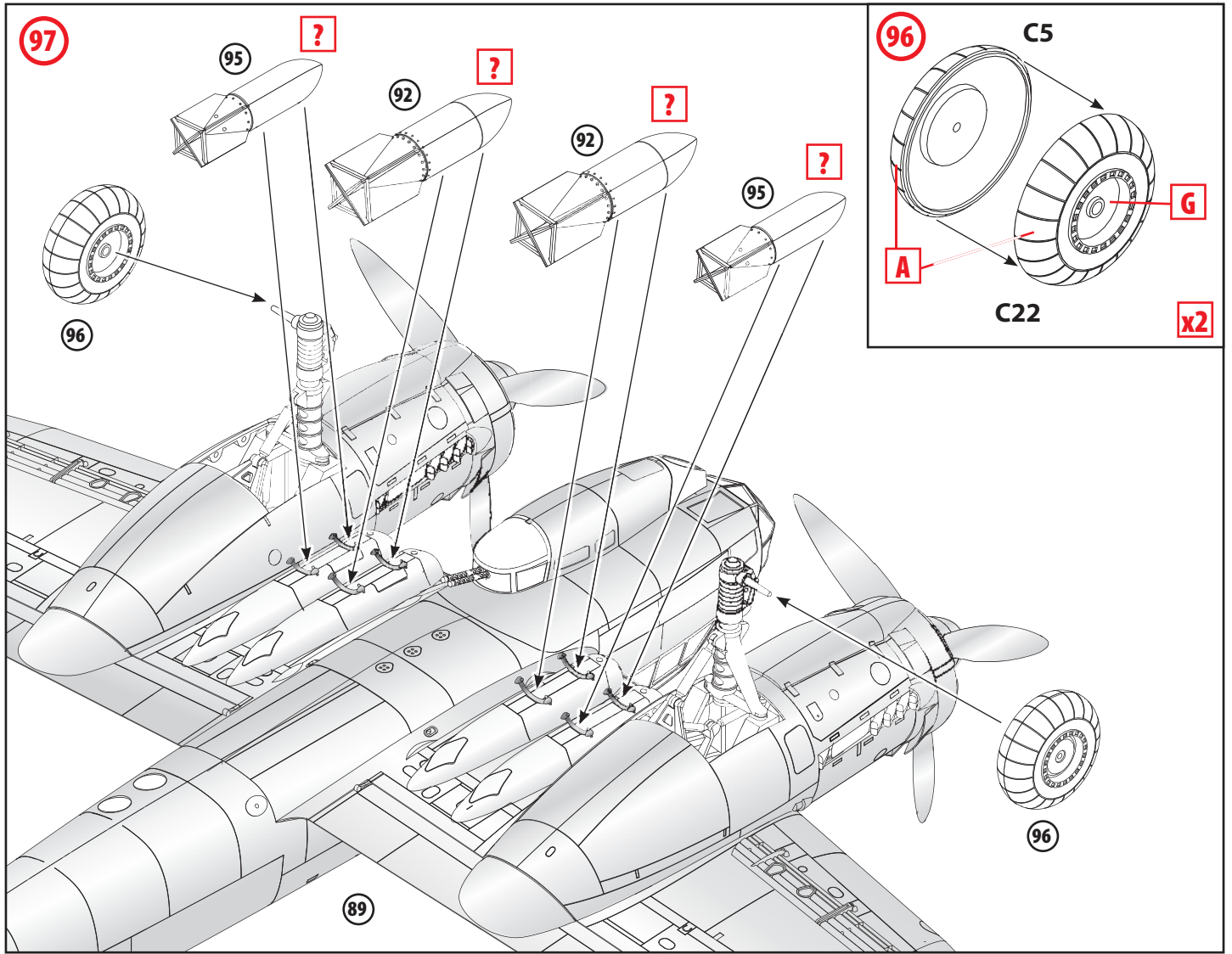

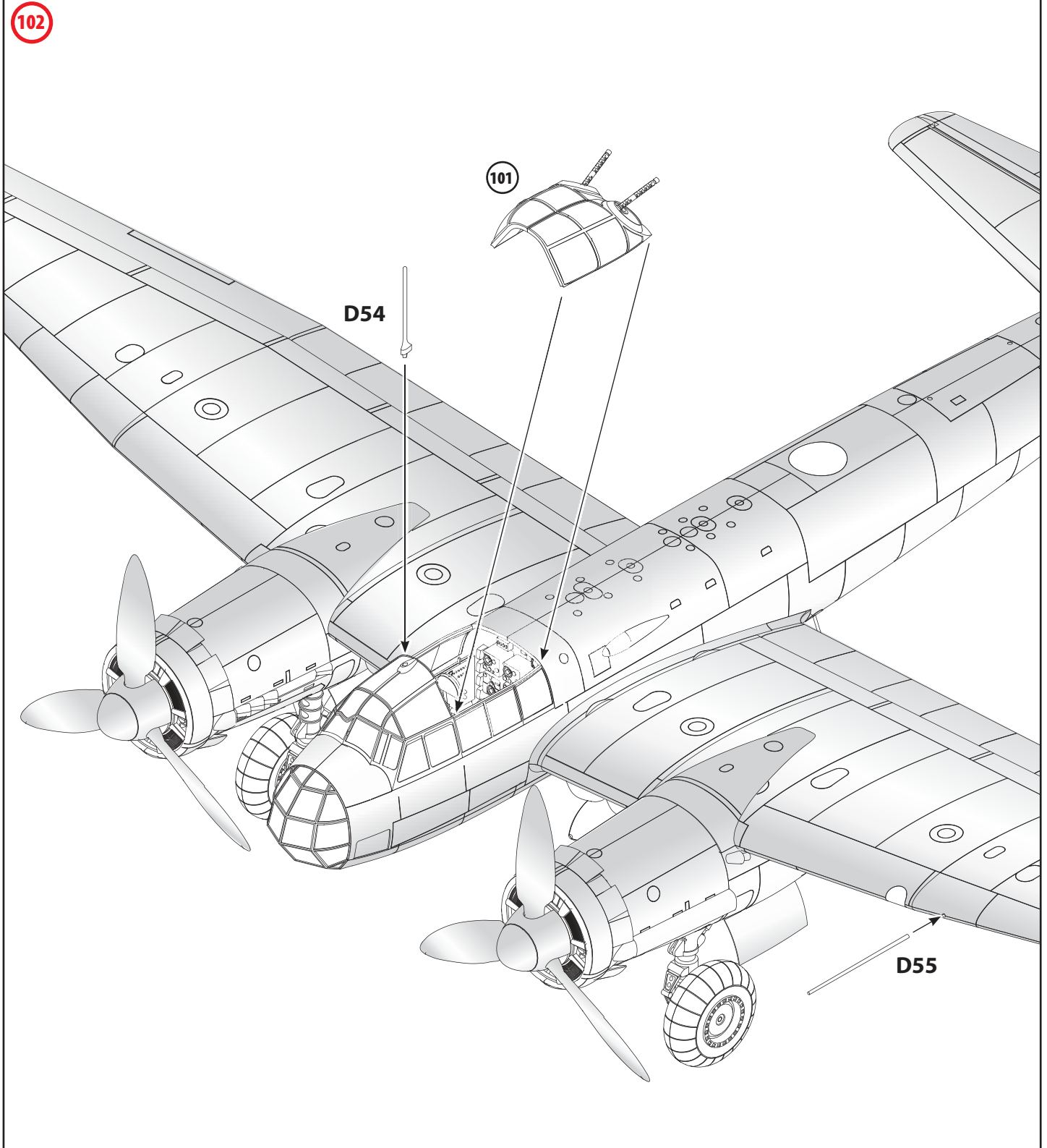
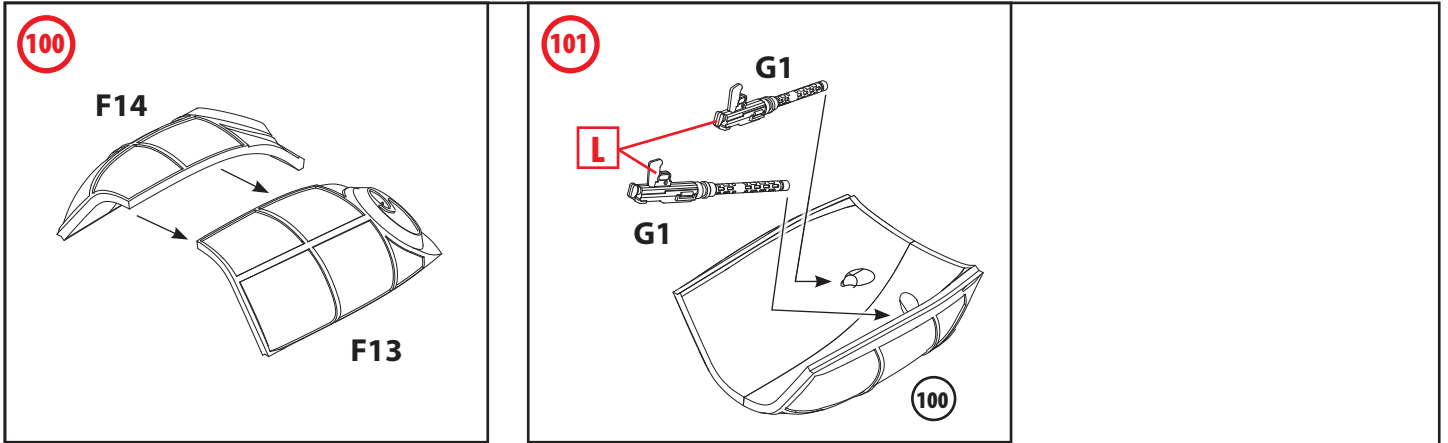

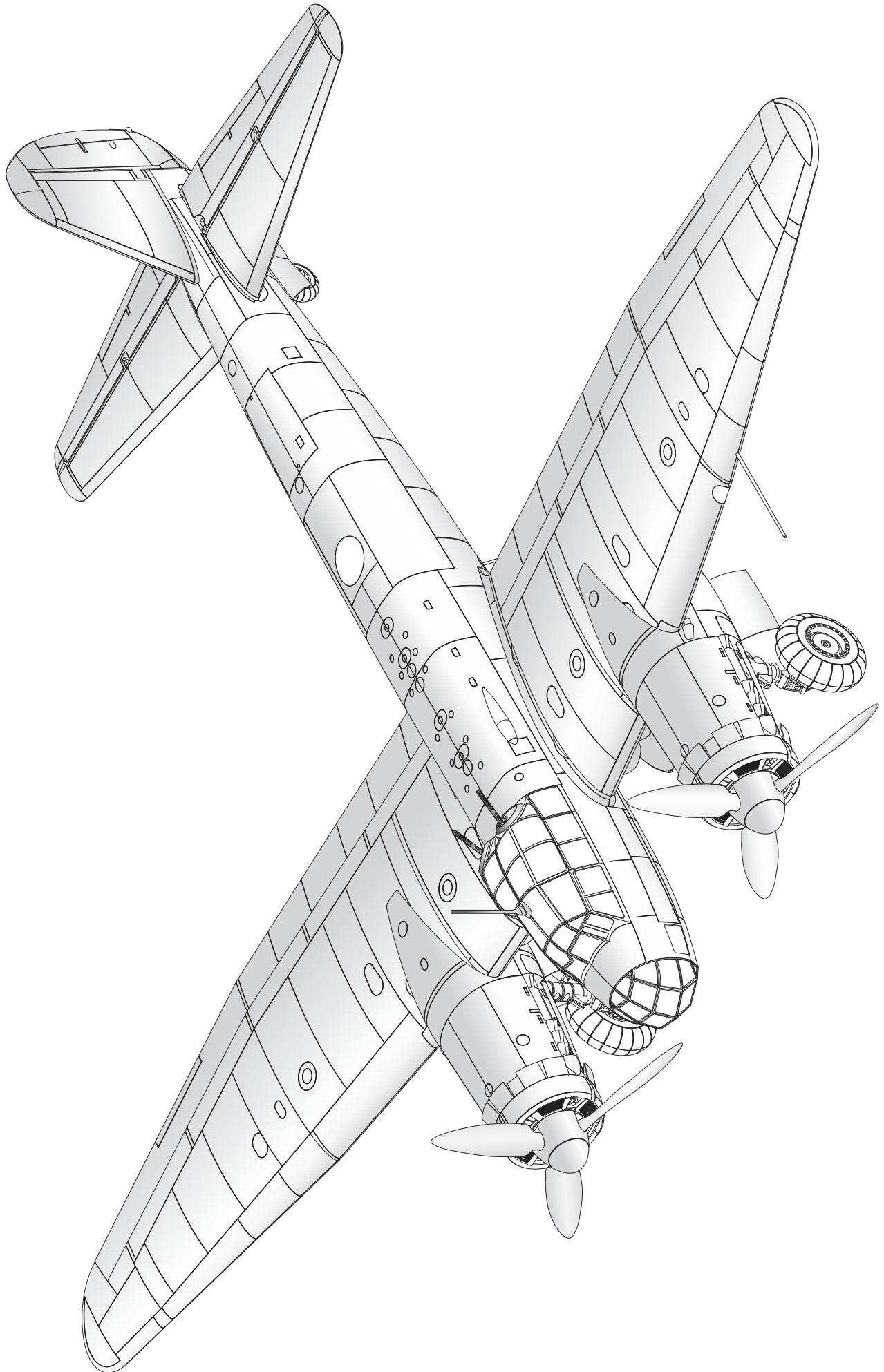

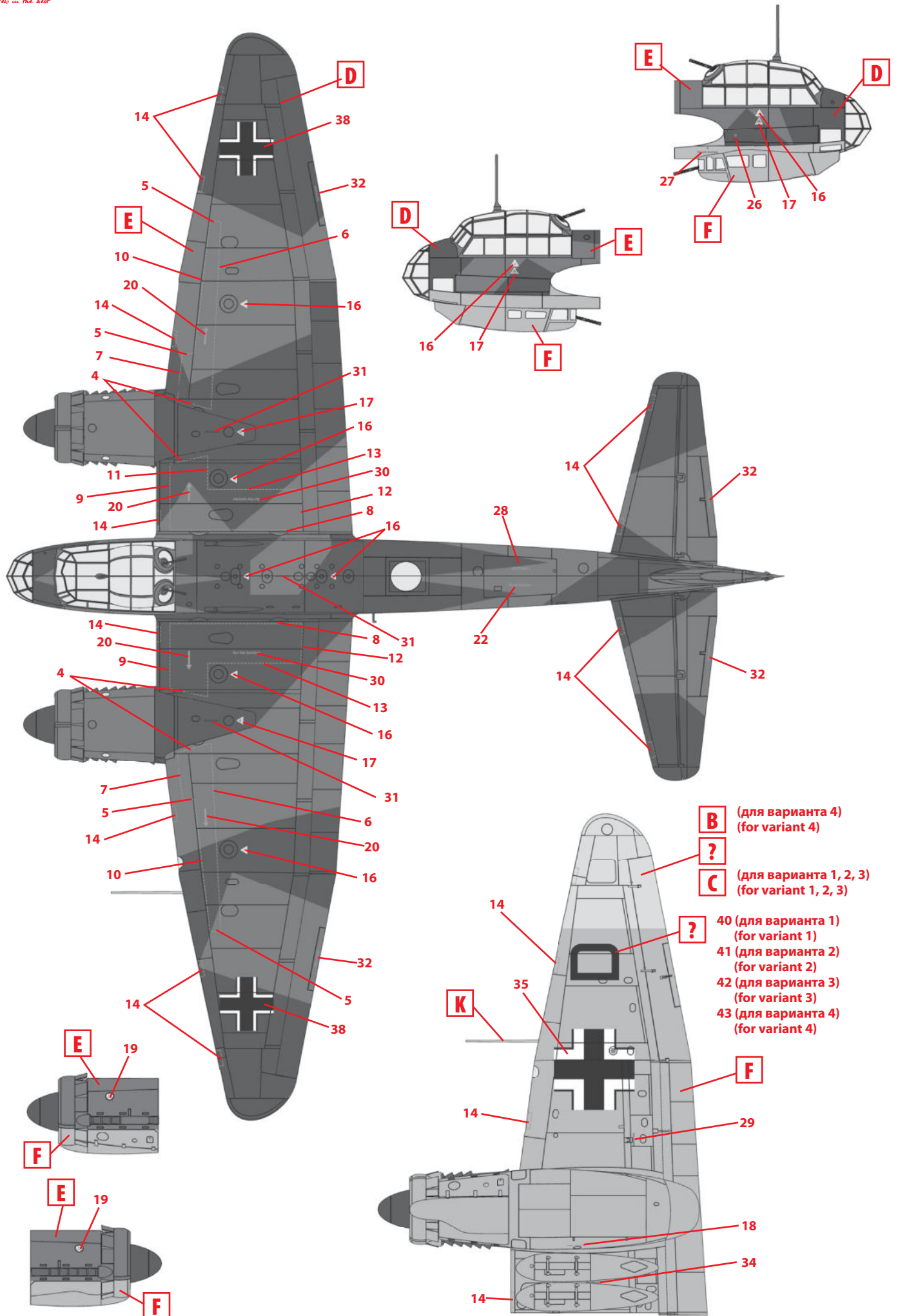

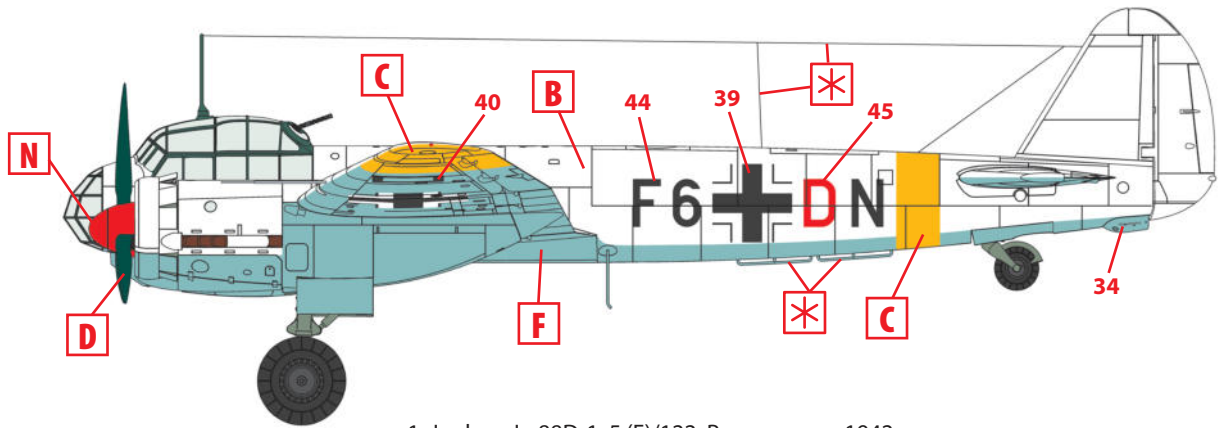

1. Junkers Ju 88D-1, 5.(F)/122, Россия, зима 1942 г.
 Junkers Ju 88D-1, 5.(F)/122, Russia, Winter 1942

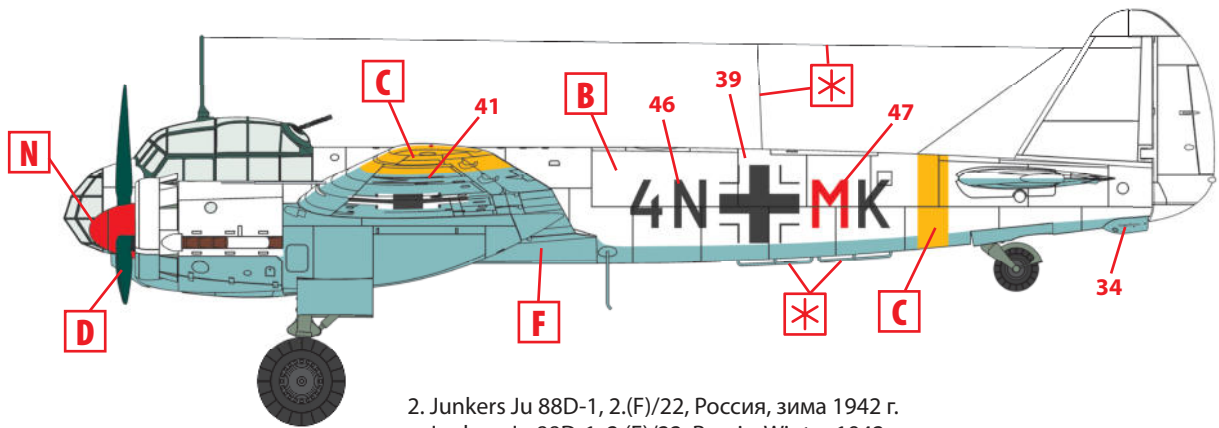
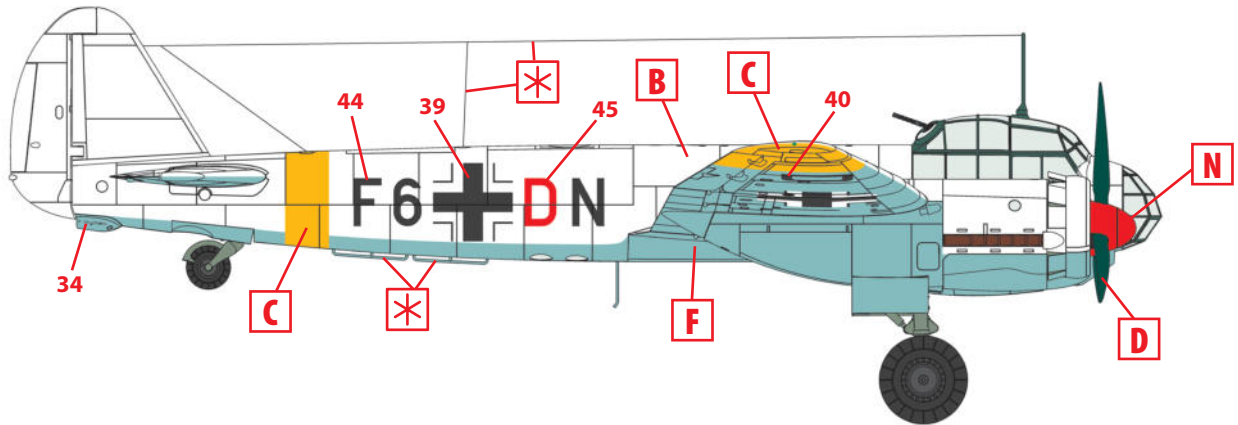

2. Junkers Ju 88D-1, 2.(F)/22, Россия, зима 1942 г.
 Junkers Ju 88D-1, 2.(F)/22, Russia, Winter 1942

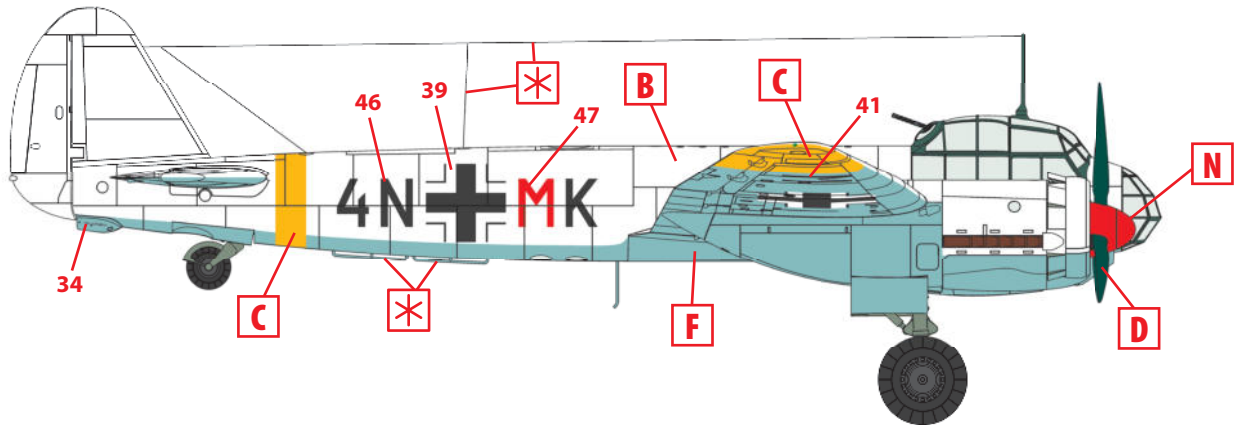

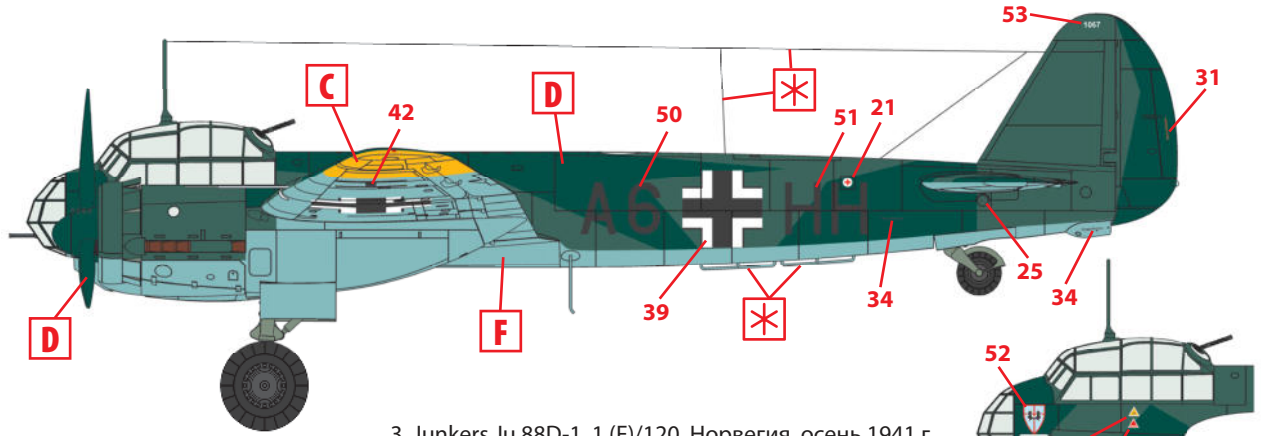

3. Junkers Ju 88D-1, 1.(F)/120, Норвегия, осень 1941 г.
Junkers Ju 88D-1, 1.(F)/120, Norway, Autumn 1941

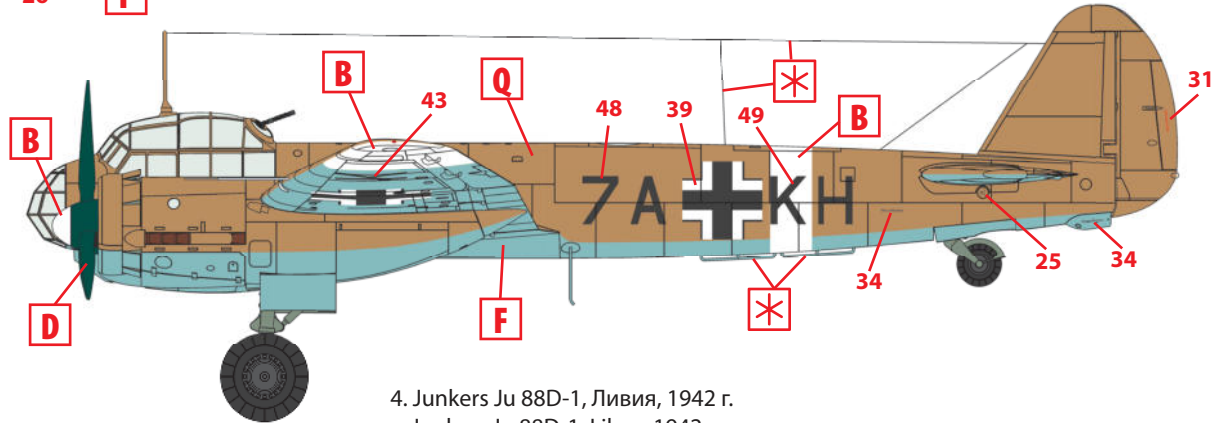
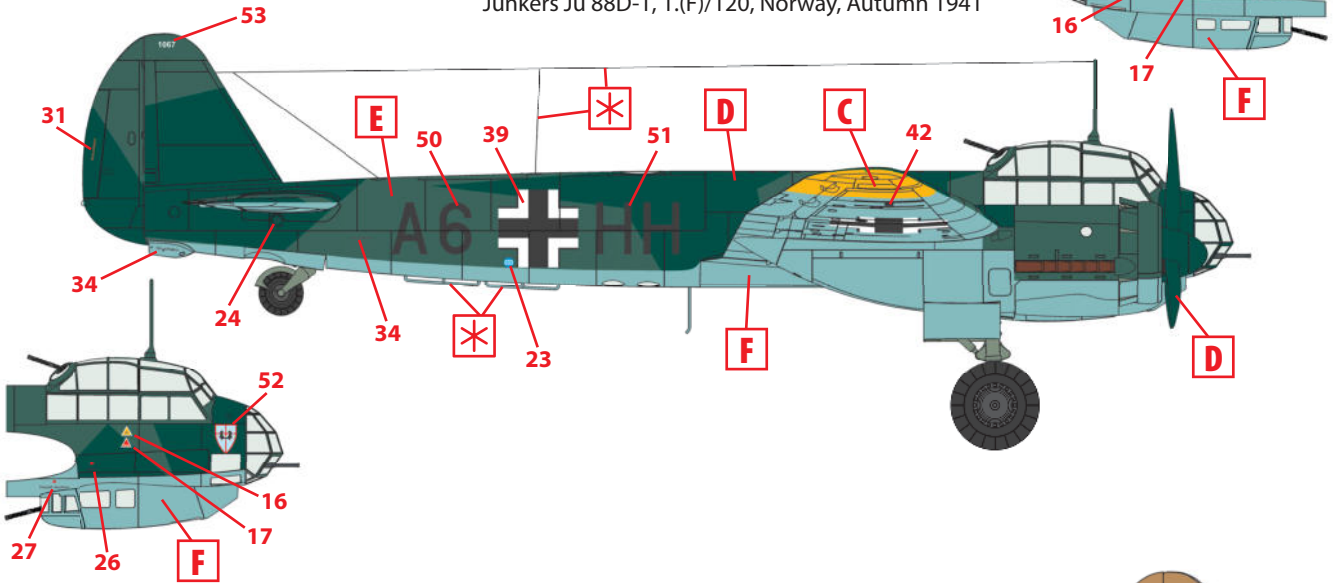

4. Junkers Ju 88D-1, Ливия, 1942 г.
Junkers Ju 88D-1, Libya, 1942

