

# Revell F-104G STARFIGHTER

B 04344 - 0389 ©1995 BY REVELL GmbH & Co. KG PRINTED IN GERMANY

**DEUTSCH-ACHTUNG:** Vor dem Zusammensetzen die Bauanleitung gut durchlesen. Jedes Teil ist nummeriert. Reihenfolge der Montageschritte beachten. Benötigte Werkzeuge: Messer und Feile zum Entfernen und Entgraten der Teile, Gummiband, Klebeband und Wäscheklammern zum Zusammenhalten der geklebten Einzelteile. Plastikteile in einer milden Waschmittellösung reinigen und an der Luft trocknen, damit der Farbanstrich und die Abziehbilder besser haften. Vor dem Ankleben prüfen, ob die Teile passen; Klebstoff sparsam auftragen. Chrom und Farbe an den Klebeflächen entfernen. Kleine Teile anstreichen, bevor sie vom Rahmen entfernt werden. Farben gut durchtrocknen lassen, erst dann den Zusammenbau fortsetzen. Jedes Abziehbildmotiv einzeln ausschneiden und ca. 20 Sekunden in warmes Wasser tauchen. Das Motiv an der bezeichneten Stelle vom Papier abschieben und mit Löschpapier andrücken.

**ENGLISH-ATTENTION:** Carefully read instruction sheet before assembling. Each part is numbered. Consider succession of assembly steps. Required tools: knife and file to remove and trim parts; rubber band, adhesive tape and clothes pegs to hold parts after cementing. Wash plastic in mild detergent solution, rinse and let air dry for better paint and decal adhesion. Scrape chrome and paint at area to be glued: Paint small parts on runner before removing. Allow paint to dry thoroughly before continuing assembly. Cut out each decal one by one and dip it in warm water for approx. 20 secs.; slide decal from the paper at the marked position and dab with blotting-paper.

**FRANCAIS: ATTENTION:** lire soigneusement la fiche d'instructions avant d'assembler. Chaque pièce est numérotée. Suivre la succession des étapes de montage. Outils nécessaires: couteau et lime pour détacher et ébarber les pièces, élastiques, papier adhésif et pinces à linge pour maintenir ensemble les pièces après collage. Laver le plastique dans une solution détergente légère, rincer et laisser sécher à l'air libre pour une meilleure adhérence de la peinture et des décalés. Ajuster les pièces ensemble avant de coller. Employer la colle Revell pour plastique exclusivement. Utiliser très peu de colle à chaque fois. Gratter le chrome ou la peinture sur les surfaces à coller. Peindre les petites pièces sur le support avant de les détacher. Laisser la peinture sécher totalement avant de continuer l'assemblage. Découper chaque décalé séparément et le plonger dans l'eau chaude environ 20 secondes. Faire glisser le décalé du papier à l'endroit du décor et tamponner avec du papier buvard.

**NEDERLANDS: OPGELET:** alvorens te beginnen met het in elkaar zetten, eerst de handleiding goed doorlezen. Elk onderdeel is genummerd. Aandacht besteden aan de volgorde van montage. Het benodigde gereedschap: mesje en vijl voor het verwijderen en het afbramen van de onderdelen, elastiek, plakband en wasknijpers gebruiken voor het bij elkaar houden van de gelijmde onderdelen. De plastic onderdelen met een zacht wasmiddel schoonmaken en laten drogen zodat de verf en de transfers beter hechten. Alvorens te lijmen, eerst vaststellen of de onderdelen

passen; de lijm zuinig opbrengen. Chrom en verf van de op elkaar te lijmen delen verwijderen. Kleine onderdelen verven vóór deze van het gietraam verwijderd worden. De verf goed laten drogen en eerst dan verder gaan met de bouw. Elk transfer apart uitknippen en ca. 20 seconden in lauw/warm water leggen. Het transfer op de juiste plaats van het papier schuiven op het model en met vloeipapier aandrukken.

**SVENSKA: VIKTIGT:** Läs noggrant igenom instruktionerna innan du börjar bygga. Varje del är numrerad. Tänk igenom ordningsföljden för de olika momenten. Följande verktyg krävs: kniv och fil för att ta loss och putsa detaljerna, gummiband, tejp och klädnypor för att hålla detaljerna på plats medan limmet torkar. Tvätta alla plastdetaljerna i mild tvålösning, skölj och låt lufttorka för att få färg och dekaler att fästa bättre. Proppassa alltid detaljerna innan du limmar. Använd endast Revells plastlim. Använd sparsamt med lim. Skrapa bort krom och färg från den yta som ska limmas: måla smådetaljerna innan du skär loss dem. Låt all färg torka ordentligt innan du fortsätter byggandet. Skär ut varje dekål för sig och blöt den i ljummet vatten i ungefär 20 sekunder, och låt dekålen glida av papperet och ner på det markerade läget: sug sedan försiktigt upp det mesta vattnet med läskpapper eller en tygtrasa.

**ITALIANO: Attenzione:** Leggere attentamente le istruzioni prima dell'assemblaggio. Ogni pezzo è numerato. Tener presente la successione delle fasi di assemblaggio. Attrezzi necessari: coltello e lima per rimuovere e rifinire le parti elastiche nastro adesivo e spilli per tenere le parti dopo averle incollate. Lavare la plastica con un detergente delicato, sciacquare e lasciar asciugare all'aria per una migliore adesione della vernice e delle 'decal'. Accoppiare le parti da incollare. Usare solamente 'Revell plastic cement'. Usare poco collante. Grattare la cromatura e la vernice nei punti da incollare. Dipingere i piccoli accessori sul supporto prima di rimuoverli. Far seccare bene la vernice prima di continuare nell'assemblaggio. Ritagliare una per una le 'decal' ed immergerle in acqua tiepida per circa 20 secondi. Applicare ogni 'decal' nella posizione segnata e tamponare con della carta assorbente.

**ESPAÑOL: ATENCIÓN:** cuidadosamente lean la hoja de instrucciones antes del montaje. Cada pieza es numerada, consideren la sucesión de las operaciones de montaje. Herramientas requeridas: cuchilla y lima para quitar y desbarbar las piezas, banda de caucho, cinta adhesiva y pinzas para sujetar las piezas, después de engomárlas. Lavar el plástico en solución détergente suave, aclarar y dejar que se seque al aire para una mejor adhesión de la pintura y la calcomanía. Adaptar las piezas bien juntas antes de encolar. Solamente utilizar pegamento plástico Revell. Utilizar el pegamento cuidadosamente y sin exceso. Raspar el cromado y la pintura en la zona que ha de ser encolada: Pintar las piezas pequeñas giratorias antes de sacarlas. Dejar que la pintura se seque totalmente antes de continuar el montaje. Cortar cada calcomanía una por una y sumergirla en agua caliente durante aproximadamente 20 segundos. Deslizar la calcomanía del papel en la posición marcada y golpearla suavemente con el papel secante.

Form hergestellt und im Eigentum von Revell GmbH & Co. KG/Revell Monogram Inc. **Widerrechtliche Nachahmungen werden gerichtlich verfolgt.** Ce produit est propriété de la société Revell GmbH & Co. KG/Revell Monogram Inc. Toute utilisation ou duplication frauduleuse fera l'objet de poursuites en justice. **Modelado y en propiedad de Revell GmbH & Co. KG/Revell Monogram Inc. Imitaciones ilícitas serán perseguidas por la ley.** Forma prodotta dalla Revell GmbH & Co. KG/Revell Monogram Inc. e di proprietà della stessa impresa, la quale procederà legalmente contro ogni imitazione abusiva. **Mall on Revell GmbH & Co. KG/Revell Monogram Inc. valmistaja ja omistajana.** Laittoaan kopiointiin tullaan puuttamaan oikeudellisin toimin. Formen produceret og er i Revell GmbH & Co. KG/Revell Monogram Inc. Eftersligning uten tillatelse vil bli jensstand for rettslig forfølgelse. **Produkcja i własności firmy Revell GmbH & Co. KG/Revell Monogram Inc. Malowania podrabiane jest zabronione pod odpowiedzialnością sądową.** Model, Revell GmbH & Co. KG/Revell Monogram Inc. finansijn mülkiyeti altında imal edilmiştir. Kanuna aykırı taktiller mahkemeye talip edilcektir. **A forma előállítója és a tulajdonosja bíróságra a Revell GmbH & Co. KG/Revell Monogram Inc. A jogellenes utáratások és hamisítványok bírósági úttalczk.**

Mould manufactured by and property of Revell GmbH & Co. KG/Revell Monogram Inc. (legal imitations are subject to prosecution). **Vorm vervaardigd door en eigendom van Revell GmbH & Co. KG/Revell Monogram Inc. Onrechtmatige nabootsingen worden gerechtelijk vervolgd.** Formas produzidas e de propriedade da Revell GmbH & Co. KG/Revell Monogram Inc. Cópias não autorizadas serão processadas judicialmente como determinado na lei. **Modellen tillverkad av och tillhör Revell GmbH & Co. KG/Revell Monogram Inc. All kopiering beivras enligt lagen om upphovsrätt.** Formen er fremstillet af Revell GmbH & Co. KG/Revell Monogram Inc. som også har ejendommen. Lovstridige efterligninger straffes. **Modelo proizvedeno i vlasnosti proizvođača firme Revell GmbH & Co. KG/Revell Monogram Inc. Proizvođačima nepošteno preuzimanje i razvijanje kopiranja.** H japonski kmetakopiranja kmetakopiranje: omvreda kopiranja Revell GmbH & Co. KG/Revell Monogram Inc. O nepošteno preuzimanje i razvijanje kopiranja. **További jogtulajdonosi, Revell GmbH & Co. KG/Revell Monogram Inc. a jogi jogtulajdonosi. Próci másolásaim jogszabálytalanul történő másolása.** Forma je proizvedena in je vlasništvo Revell GmbH & Co. KG/Revell Monogram Inc. Neovlašene kopije bodo pravno kaznjene.

**Kleben**  
Glue  
A coller  
Lijmen  
Limmas  
Incollare  
Engomar

**Nicht kleben.**  
Don't glue.  
À ne pas coller.  
Niet lijmen.  
Timmas ej.  
Non incollare.  
No engomar.

**Anzahl der Arbeitsgänge.**  
Number of working steps.  
Nombre d'étapes de travail  
Het aantal der bouwhandelingen.  
Antal arbetsmoment.  
Numero di passaggi.  
Numero de operaciones de trabajo.

**Wahlweise**  
Optional  
Facultatif  
Ter keuze  
Valfritt  
Facultativo  
Opcional

Abziehbild in Wasser einweichen und anbringen.  
Soak and apply decals.  
Mouiller et appliquer les décalés.  
Transfer in water even laten weken en opbrengen.  
Blöt and fäst dekalerne.  
Immergere in acqua ed applicare decal.  
Remojar y aplicar las calcomanías.

**Abbildung zusammengebauter Teile.**  
Shown assembled.  
Vu assemble.  
Afbelding van een gebouwde onderdeel.  
Visas hõpsatt.  
Figura assembled.  
Presentado montado.

**Klarsichtteile**  
Clear parts  
Pièces transparentes  
Transparente onderdelen  
Genomskinnliga detaljer  
Parte trasparente  
Limpiar las piezas

**Loch bohren**  
Make a hole  
Faire un trou  
Gat boren  
Boora hål  
Fare un foro  
Hacer un agujero

<b>A</b>	<b>B</b>	<b>C</b>	<b>70%</b>	<b>D</b>	<b>30%</b>	<b>E</b>	<b>F</b>	<b>50%</b>	<b>G</b>	<b>40%</b>	<b>10%</b>
ANTHRACITE <b>ANTHRAZIT 9</b> ANTHRACITE ANTHRAZIT ANTHRAZIT	GREY <b>GRAU 57</b> GRIS GRIS GRIGIO	ALUMINIUM <b>ALUMINIUM 99</b> ALUMINIUM ALUMINIUM ALUMINIUM	METALLIC GREY <b>EISENFARBIG 91</b> GRIS METALLIQUE IJZERKLEUR JÄRNGRÅ FERRO	MATT BLACK <b>MATT SCHWARZ 8</b> NOIR MAT MATT ZWART MATT ZWART NERO SMORTO	MATT WHITE <b>MATT WEISS 5</b> BLANC MAT MATT WIT MATT WIT BIANCO SMORTO	MATT NATO OLIVE <b>MATT NATO-OLIV 48</b> OLIVE NATO MAT MATT NATO OLIV NATO OLIVGRÖN VERDE OLIVA NATO SMORTO	GREY <b>GRAU 57</b> GRIS GRIS GRÅ GRIGIO	MATT WHITE <b>MATT WEISS 5</b> BLANC MAT MATT WIT MATT WIT BIANCO SMORTO	ALUMINIUM <b>ALUMINIUM 99</b> ALUMINIUM ALUMINIUM ALUMINIUM	ALUMINIUM <b>ALUMINIUM 99</b> ALUMINIUM ALUMINIUM ALUMINIUM	ALUMINIUM <b>ALUMINIUM 99</b> ALUMINIUM ALUMINIUM ALUMINIUM

<b>H</b>	<b>I</b>	<b>J</b>	<b>K</b>	<b>L</b>	<b>M</b>	<b>N</b>	<b>O</b>	<b>P</b>
DUST GREY <b>STAUBGRAU 77</b> GRIS POUSSIÈRE STOFGRIS DAMMGRÅ GRIGIO SABBIA	ORANGE <b>LEUCHTORANGE 25</b> ORANGE ORANGE ORANGE ARANCIO	CLEAR RED <b>KLAR RÖT 731</b> CLAIRE ROUGE DOORZICHTIG ROOD KLAR RÖD CHIARO ROSSO	CLEAR BLUE <b>KLAR BLAU 752</b> CLAIRE BLEU DOORZICHTIG BLAUW KLAR BLÅ CHIARO BLU	GREENISH GREY <b>BRÜNGRAU 67</b> GRIS VERT GRÖNGRIS GRÄGRÖN GRIGIOVERDE	MATT YELLOW <b>MATT BELB 15</b> JAUNE MAT MAT GEEL MATT GUL GIALLO SMORTO	BLACK <b>SCHWARZ 302</b> NOIR ZWART SVART NERO	BEIGE <b>BEIGE 314</b> BEIGE BEIGE BEIGE BEIGE	MATT BLUE <b>MATT BLAU 56</b> BLEU MAT MAT BLAUW MATT BLÅ BLU SMORTO

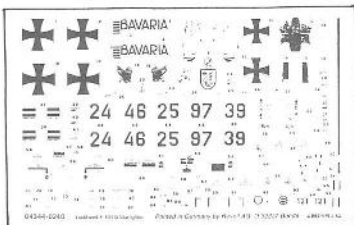
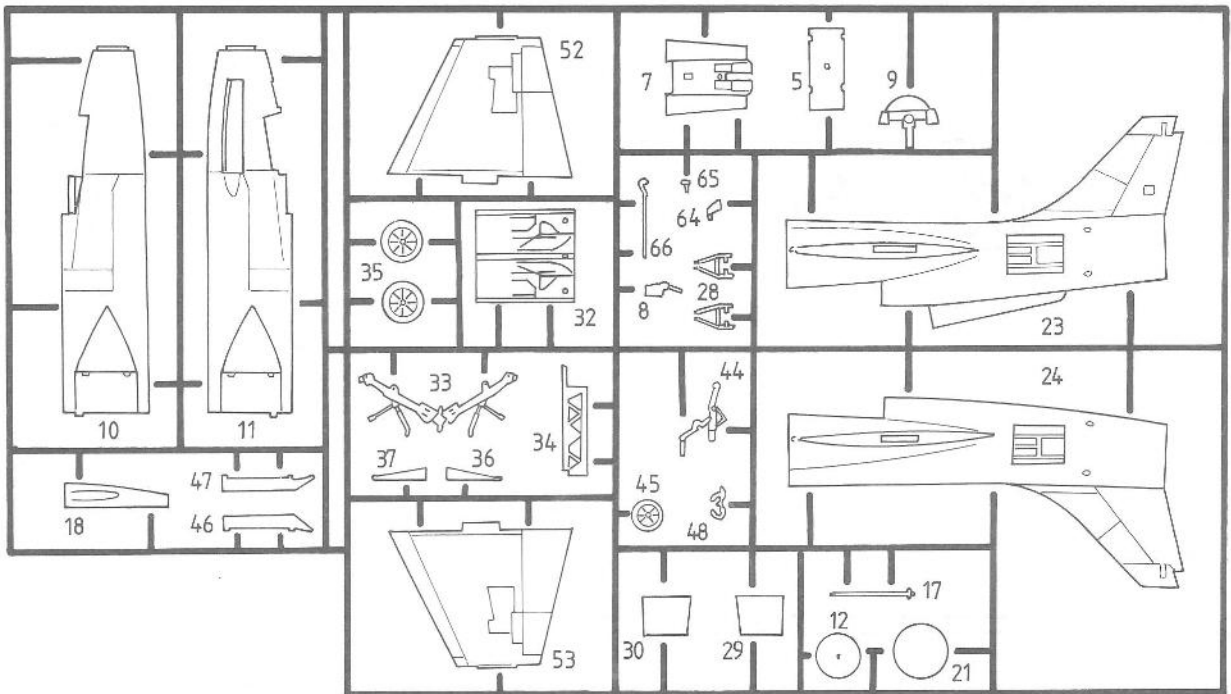
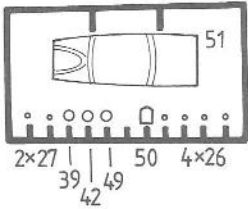
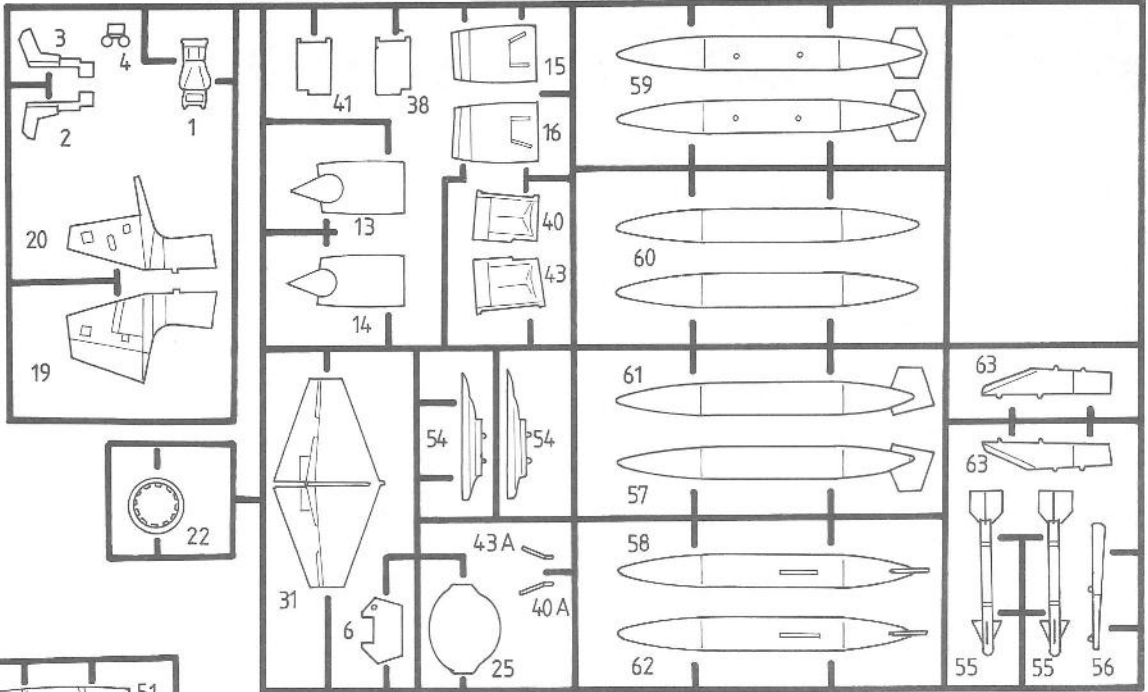



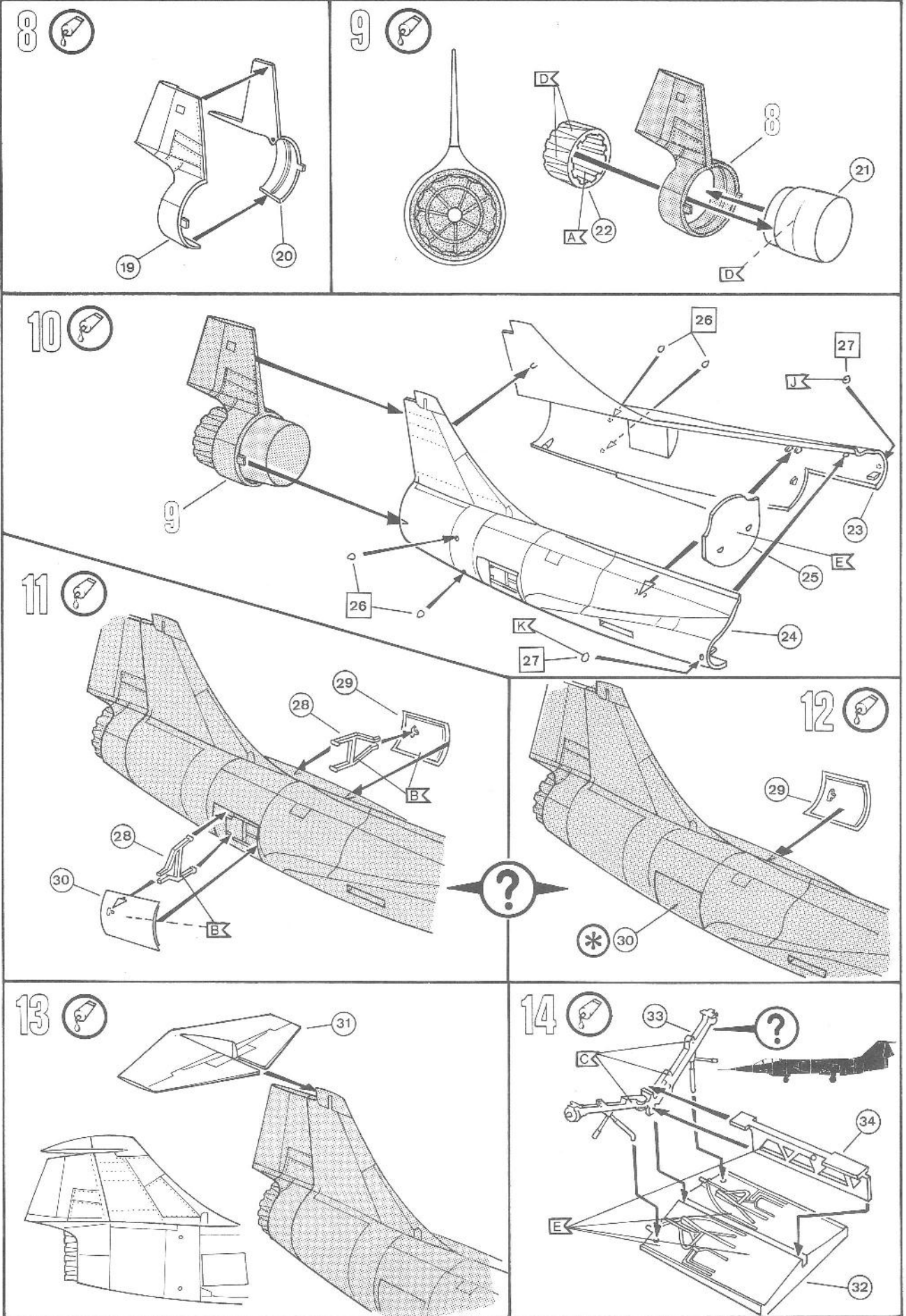

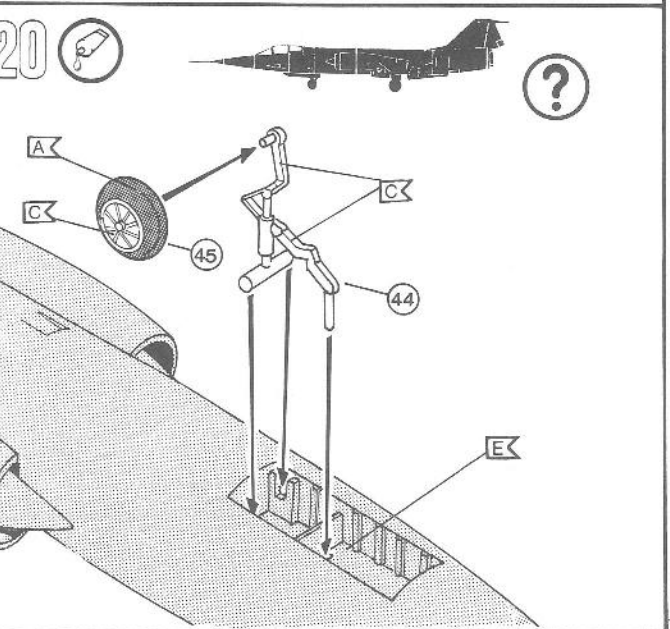
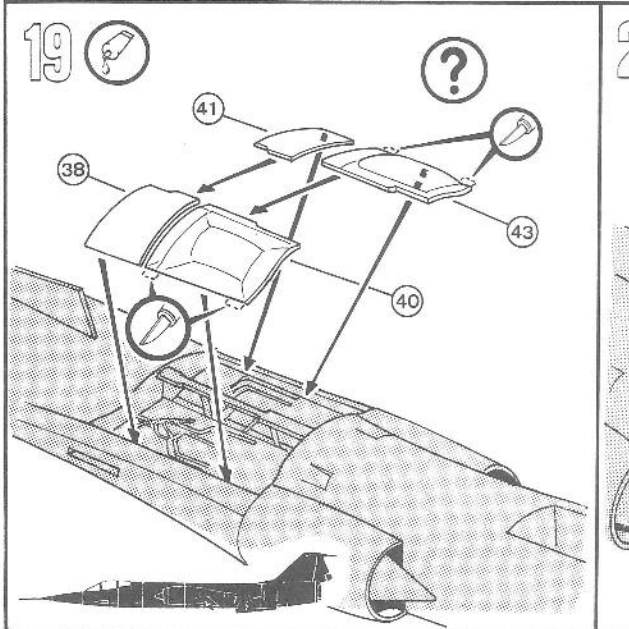
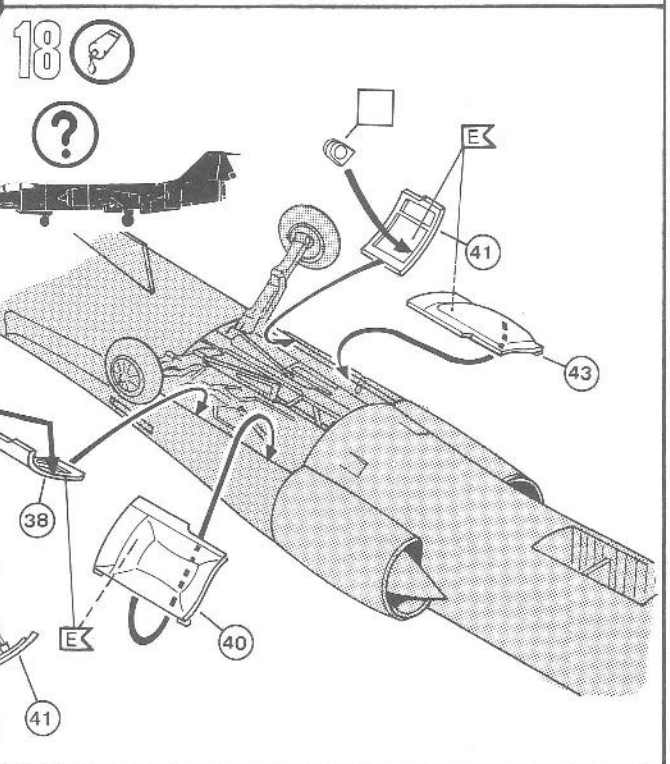
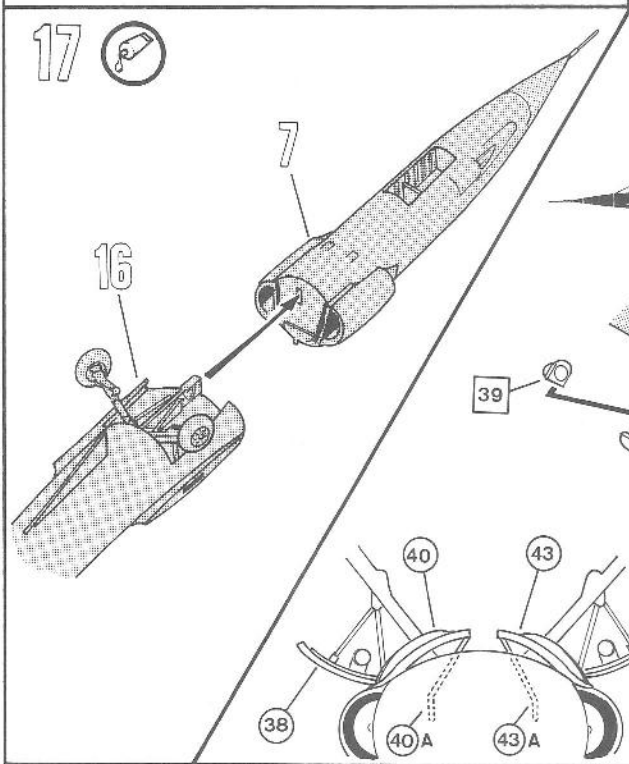
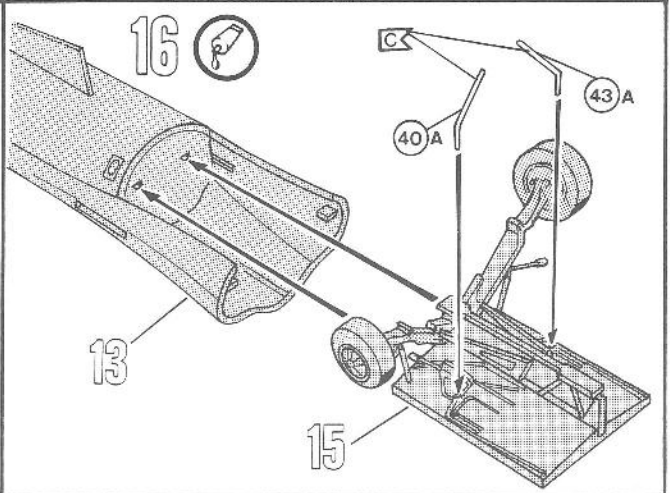
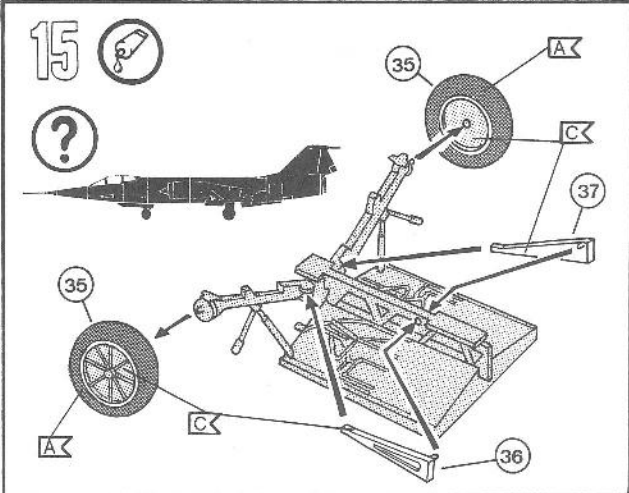

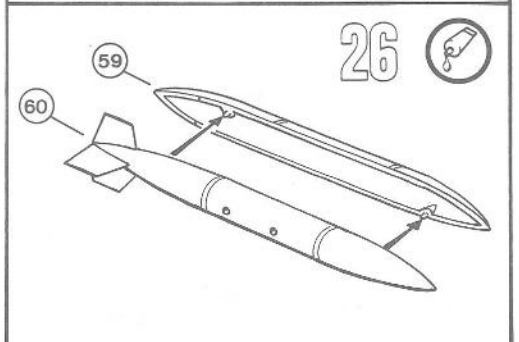
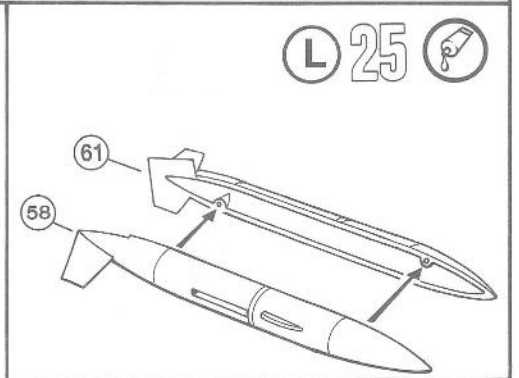
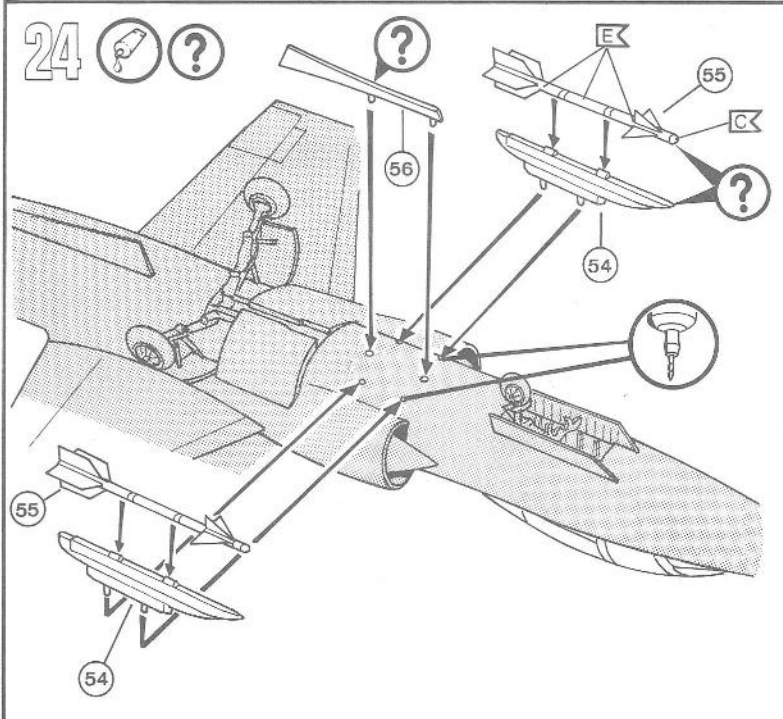
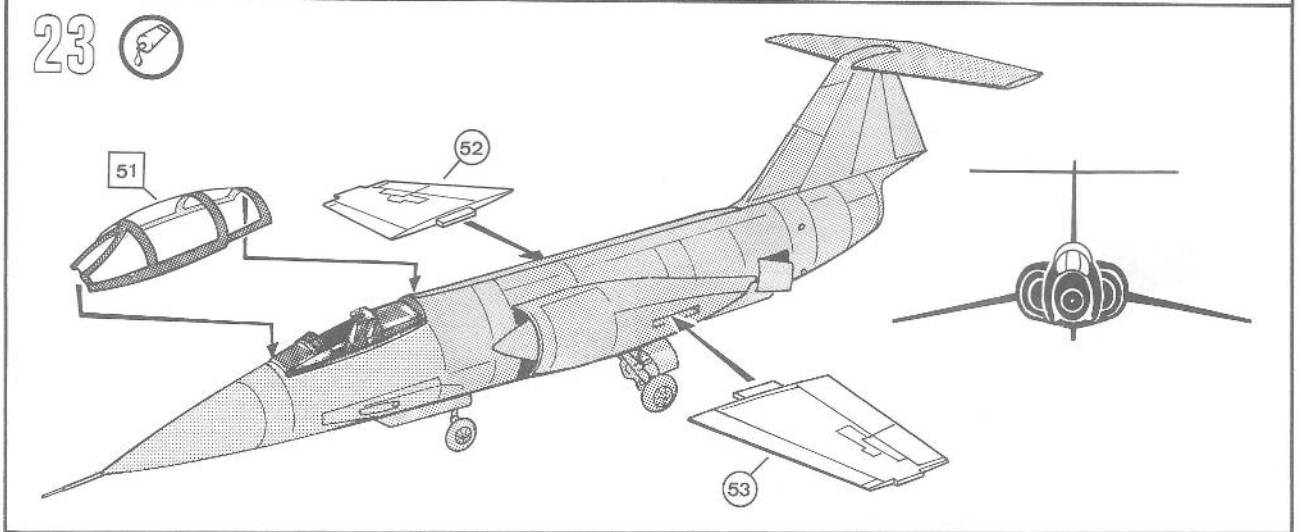
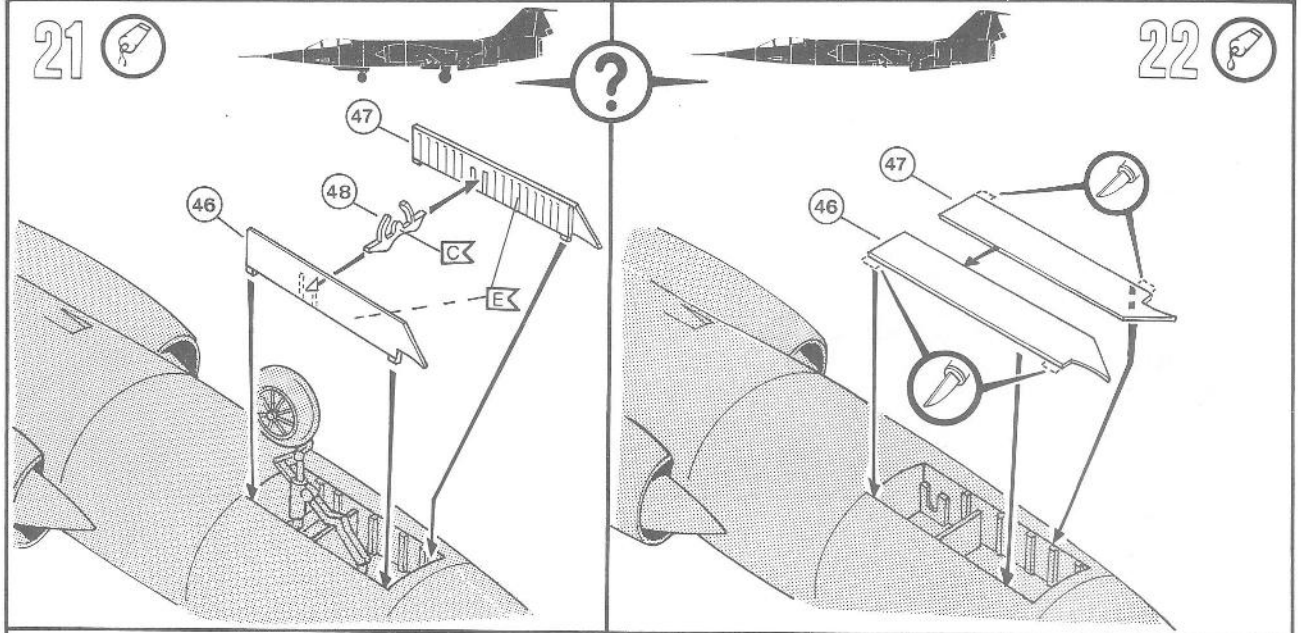

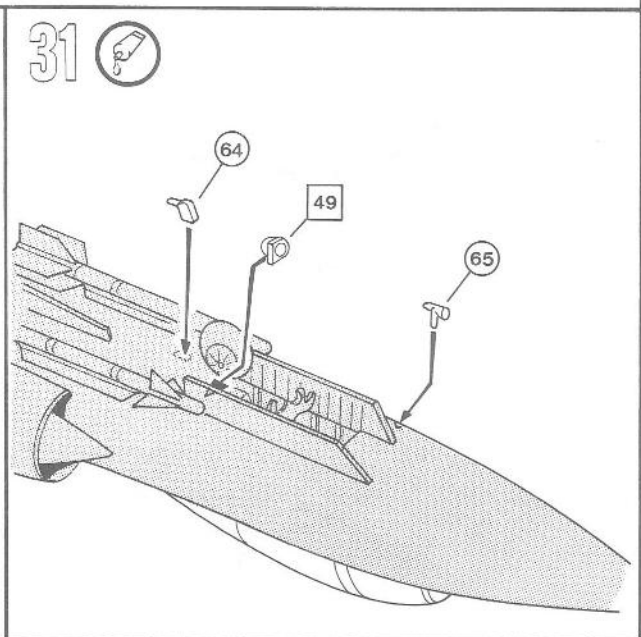
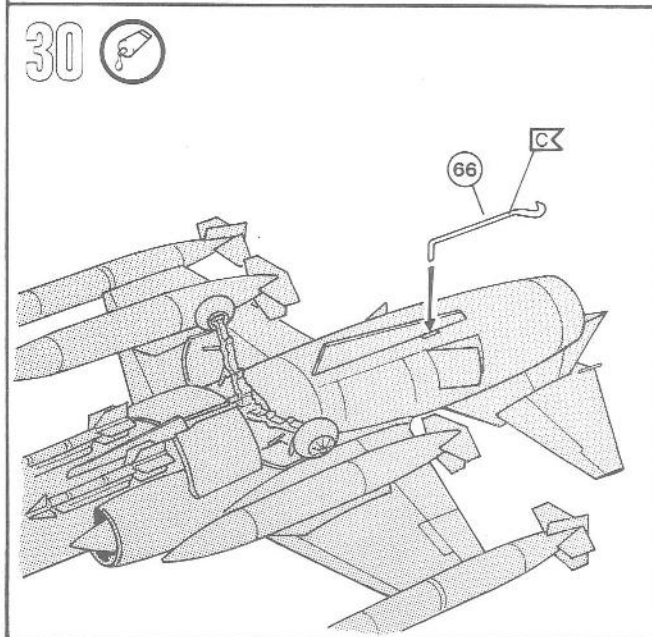
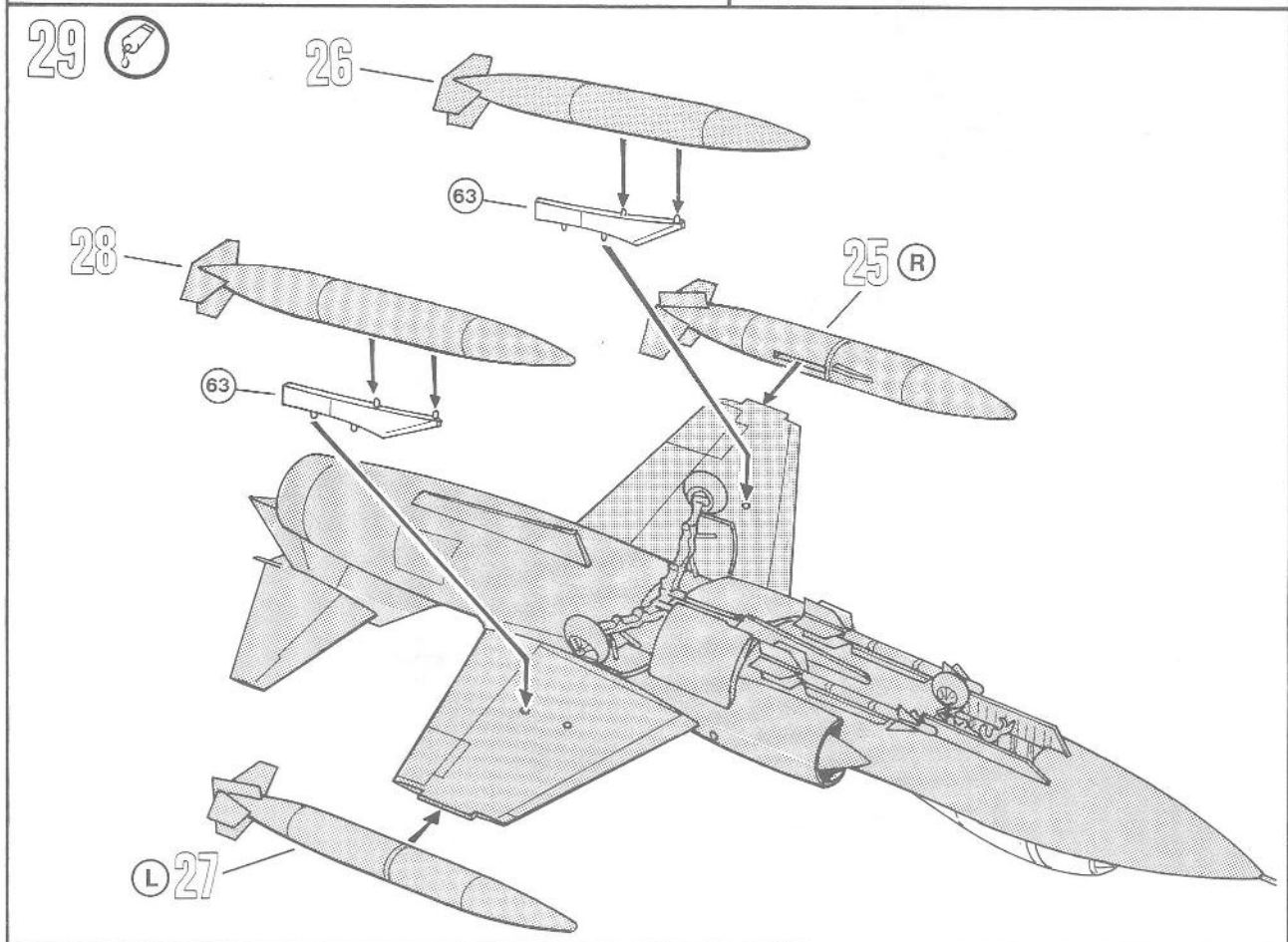
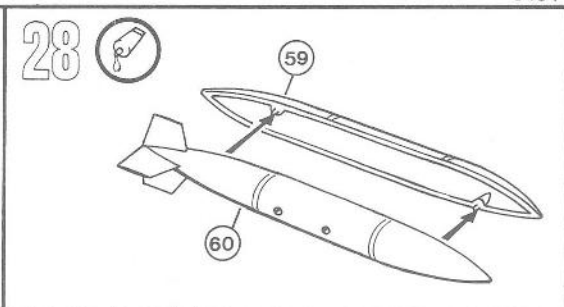
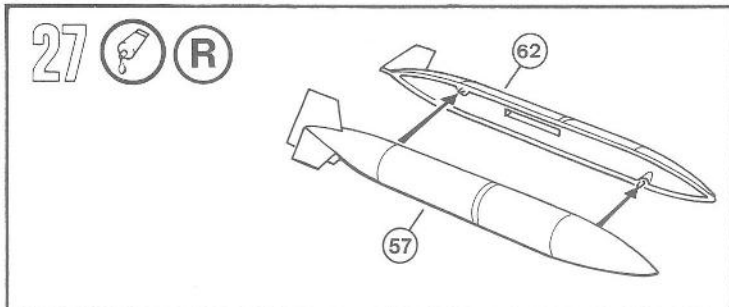

32

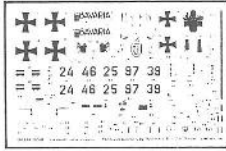

RAL 7001



RAL 6014

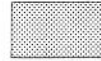

RAL 7012



RAL 9001



RAL 5017

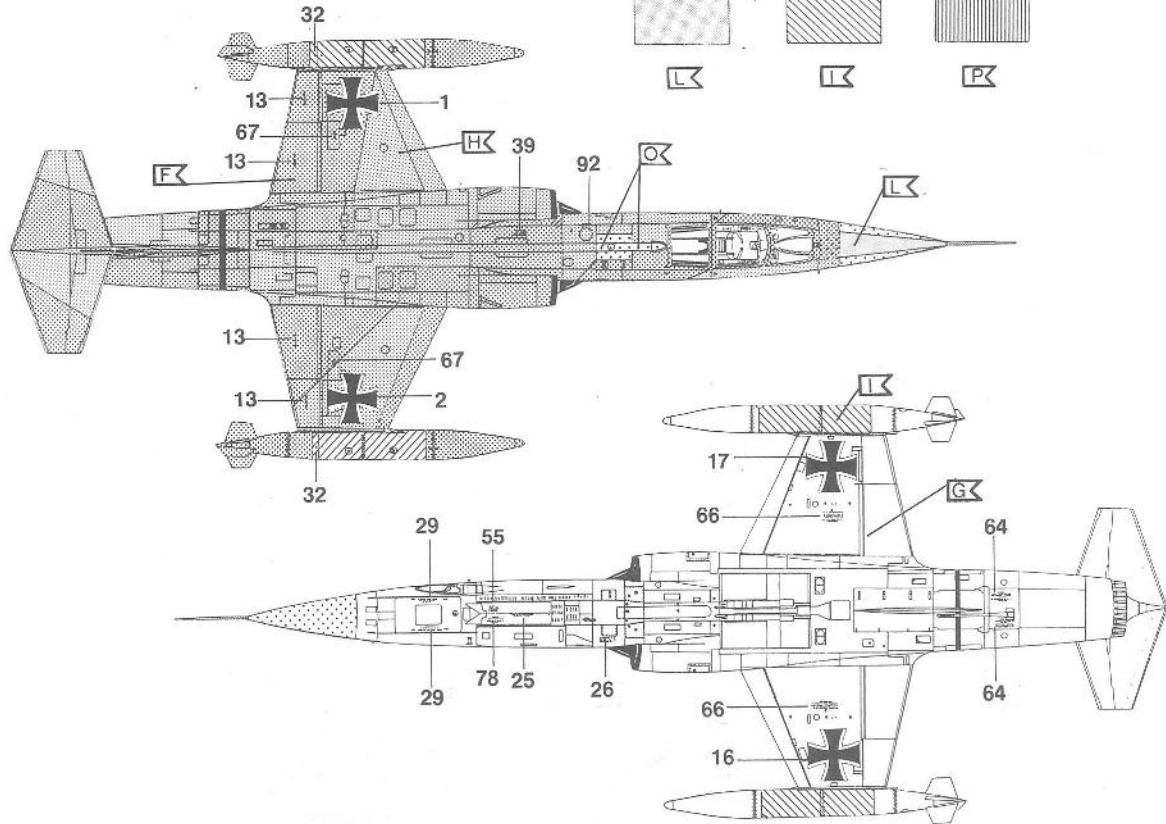
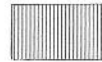

F-104G Starfighter,  
Jabo G 32, Lechfeld,  
Tactical Weapons Meet 1976 in  
Twenthe/Holland

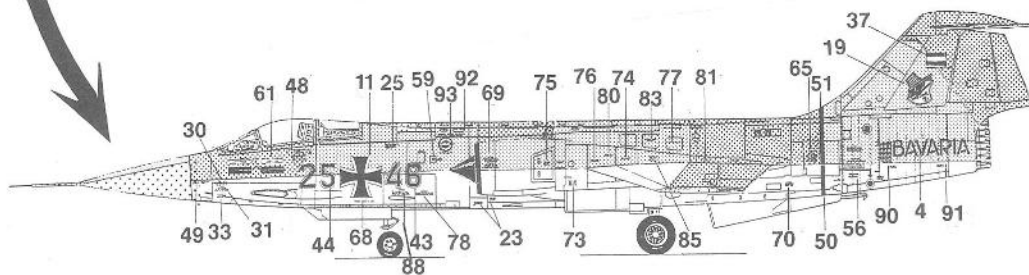
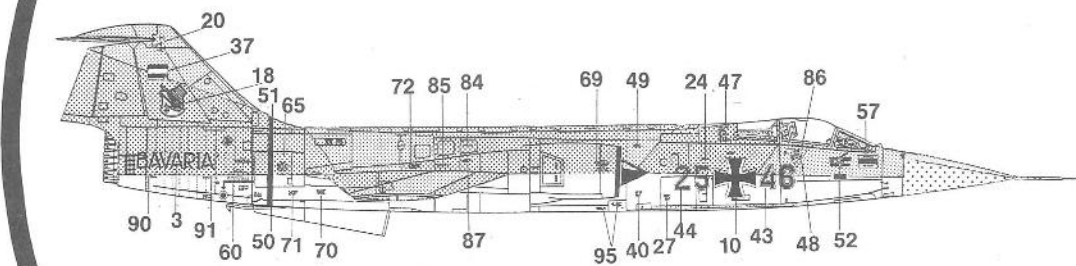



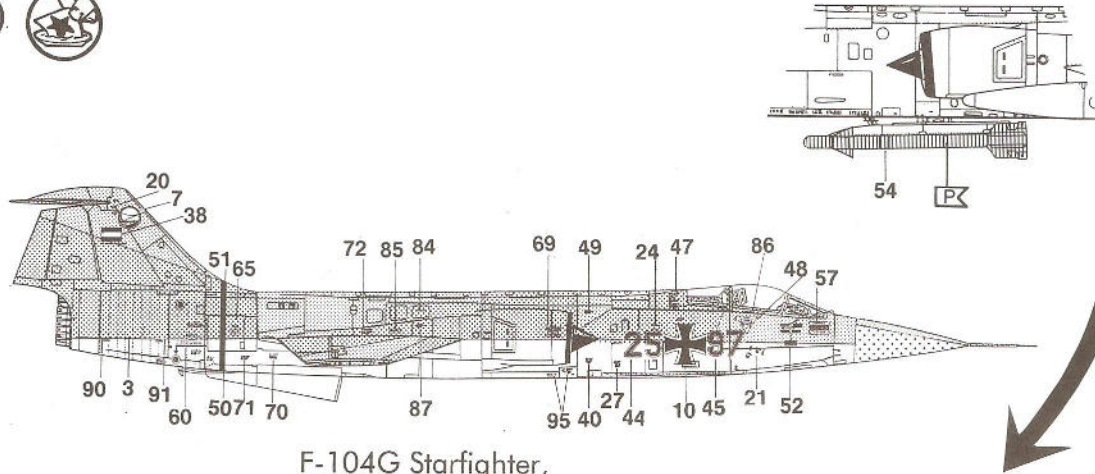

F-104G Starfighter,  
JG 74 „Mölders“ in Neuburg/Donau  
Ende 1973

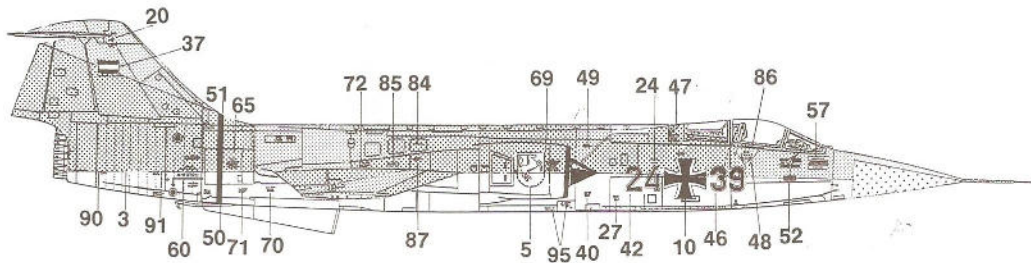
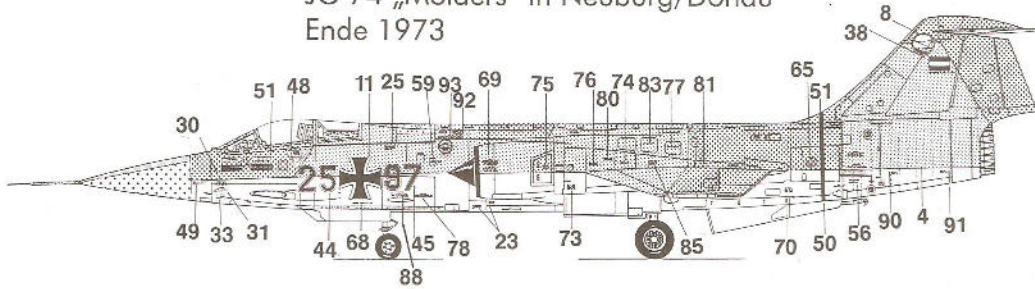

F-104G Starfighter,  
Jabo G 36 in Rheine/Westfalen

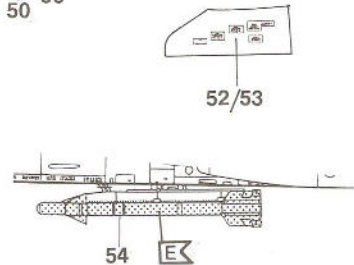
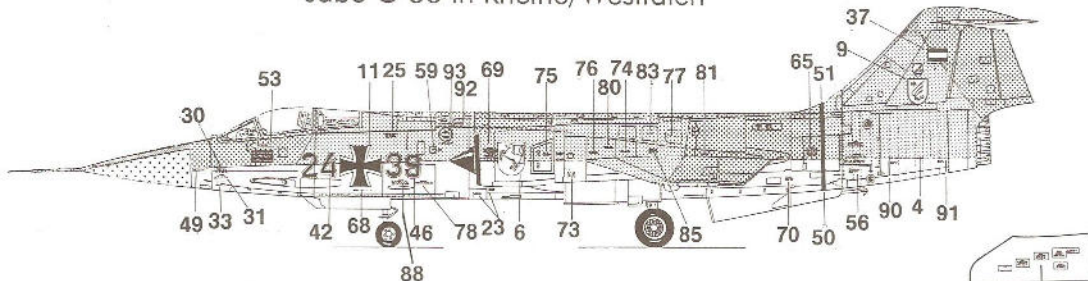

# 33



## F-104G Starfighter German Navy. Common all versions.

Pylon F-104G

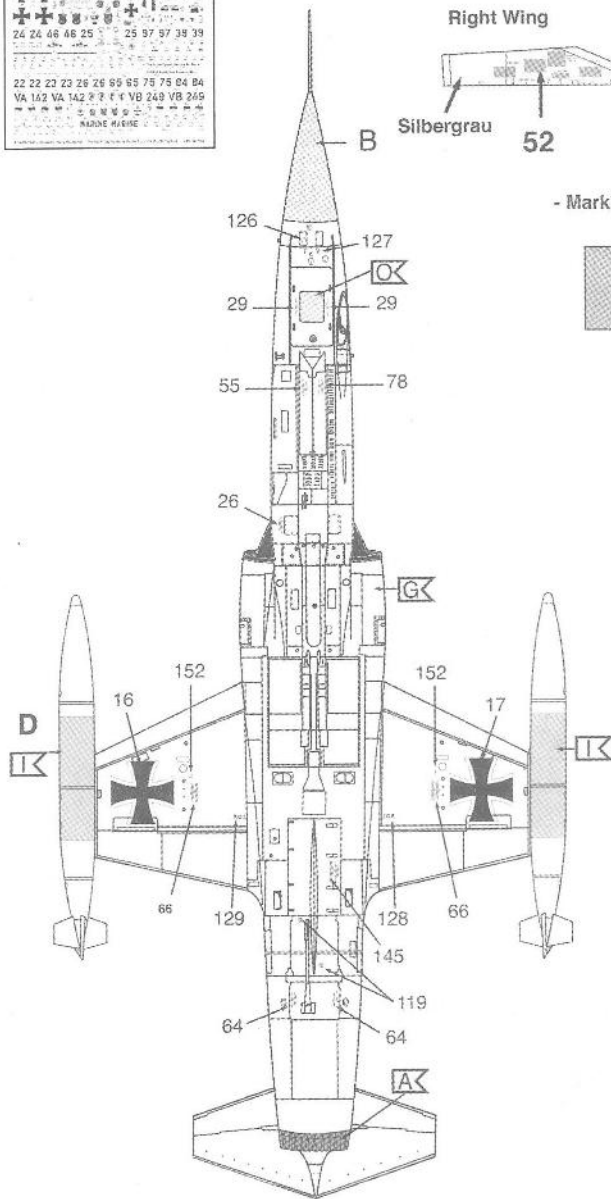
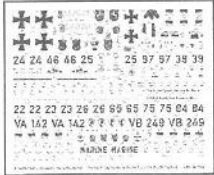

- Markings on Outside only ! -



blaugrau, matt 79  
greyish blue, matt  
gris-bleu, mat  
blauwgris, mat  
gris azulado, mate  
cinzento azulado, fosco  
grigio blu, opaco  
blágrá, mat  
sinimermaa, himmeä  
blágrá, mat  
сіне-серпін, матовий  
siviy, matowy  
γκριζομπλέ, ματ  
navi gri, mat  
modrošedá, matná  
kékesszürke, matt  
plavo siva, mat

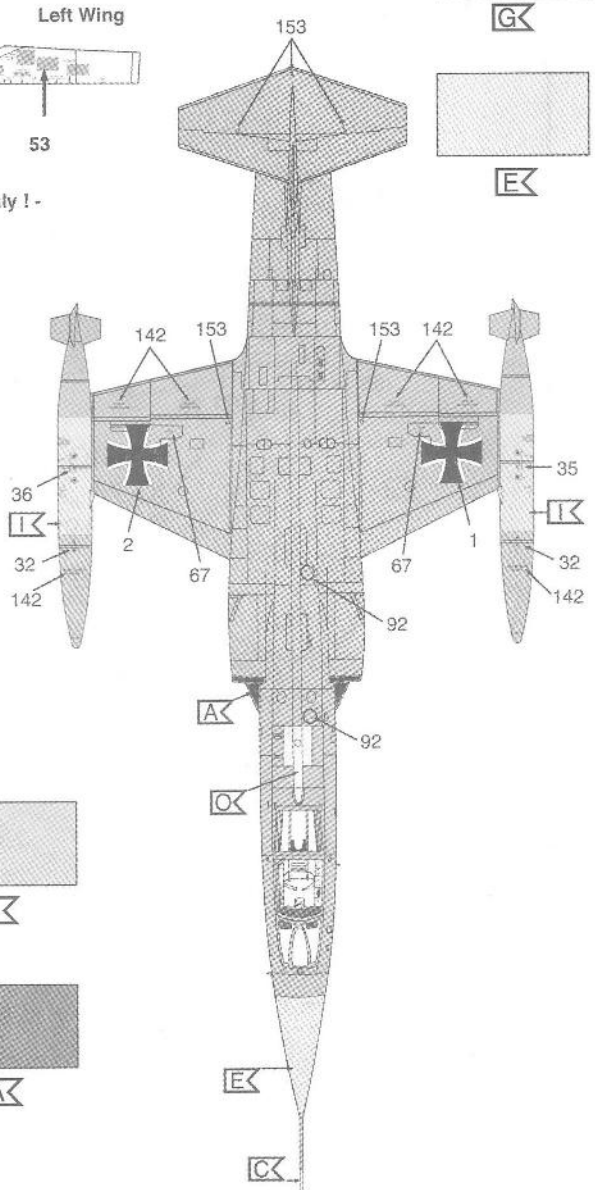

# 34



## Lockheed F-104G Starfighter Marineflieger Geschwader 1, Jagel Germany

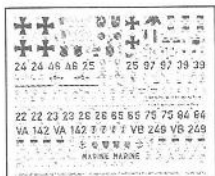
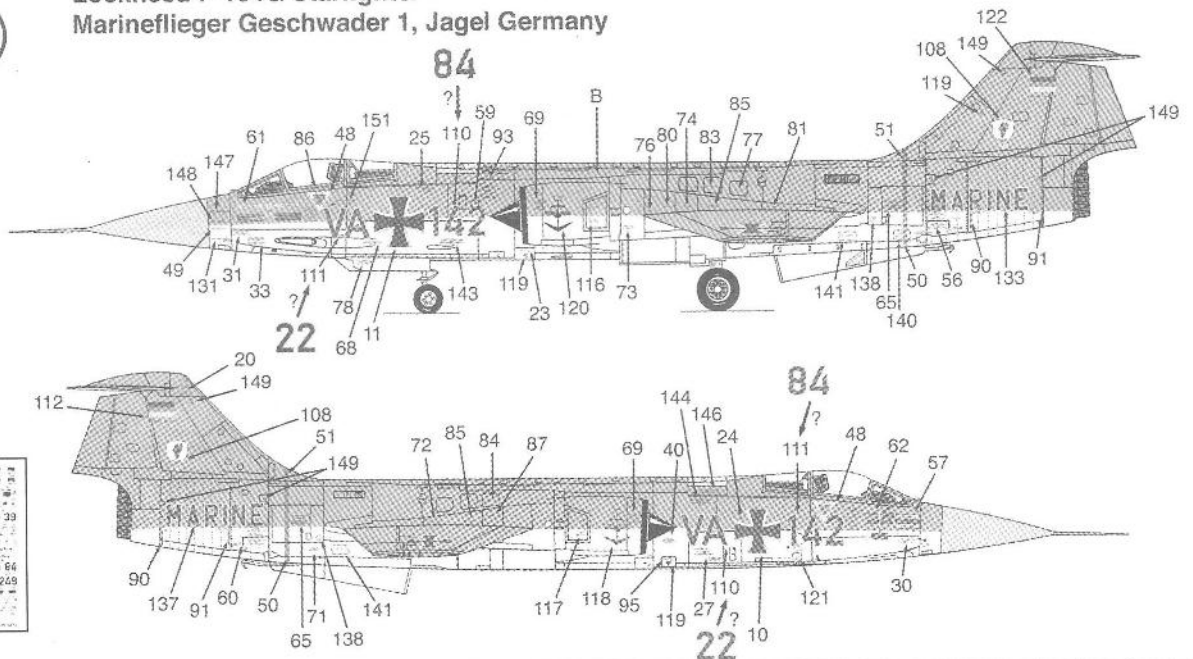

35

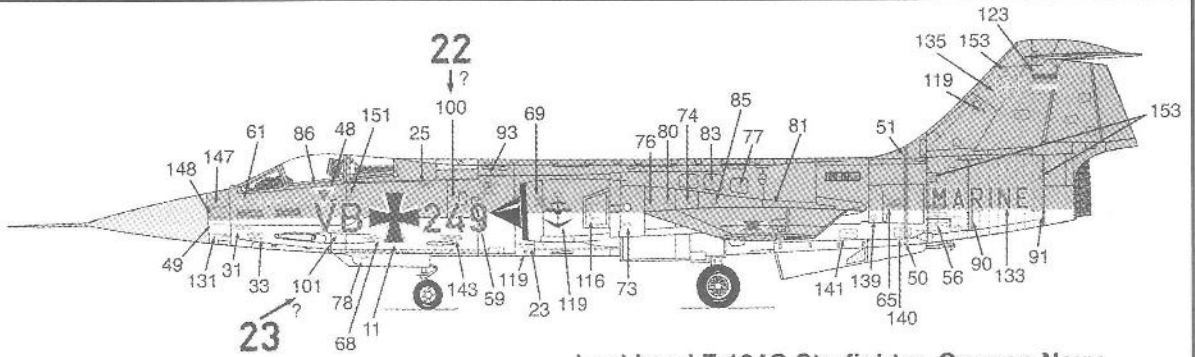
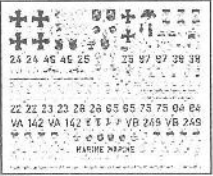

Lockheed F-104G Starfighter, German Navy  
Marineflieger Geschwader 2, Eggebeck, Germany;

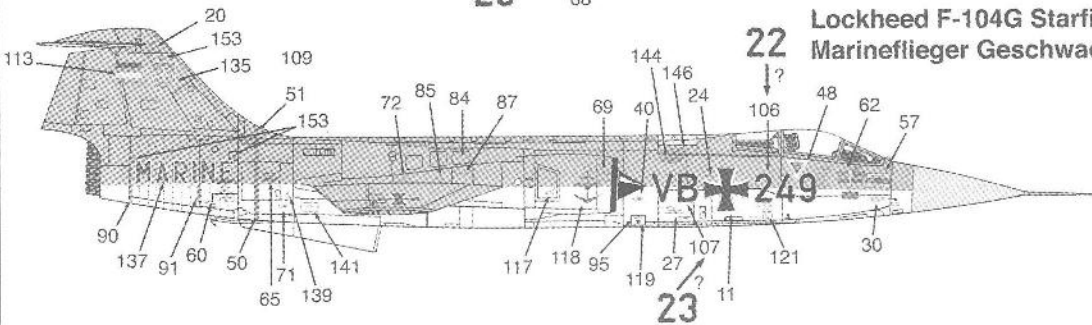

36

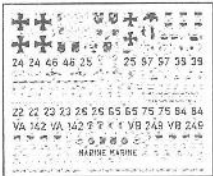

Lockheed F-104G Starfighter, German Navy  
Marineflieger Geschwader 1, Jagel, Germany  
"Bulls Eye 79" Weapons Meet 1979

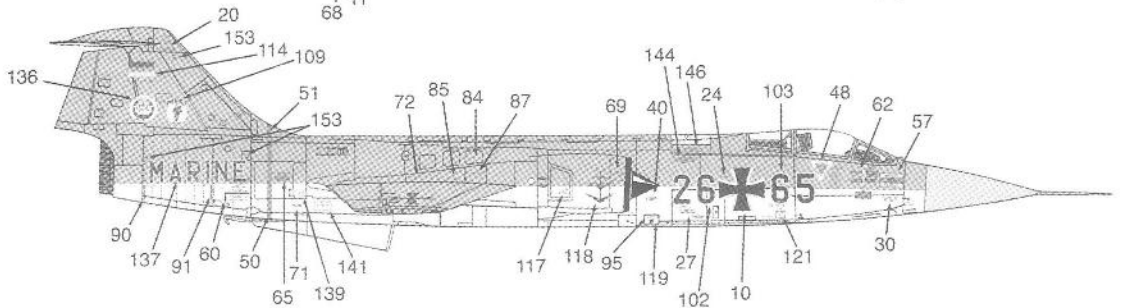
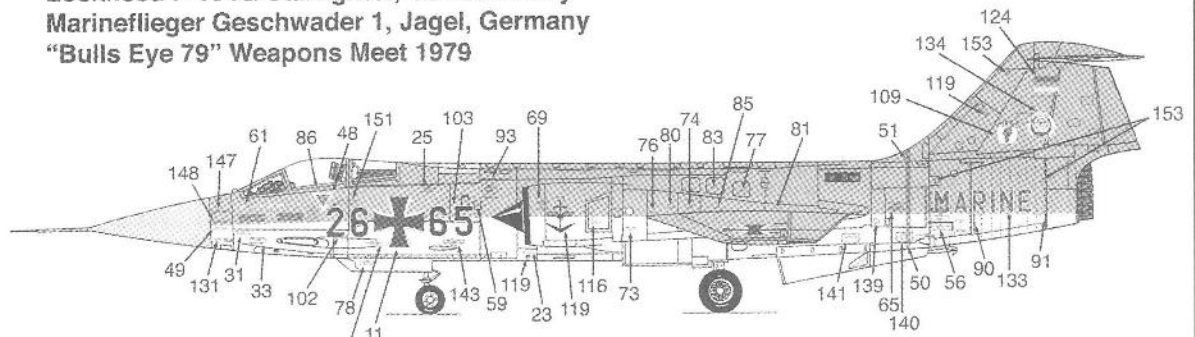

37

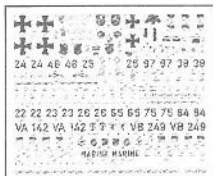

Lockheed F-104G Starfighter, German Navy  
Marineflieger Geschwader 2, Eggebeck, Germany  
"Bulls Eye 79" Weapons Meet 1979

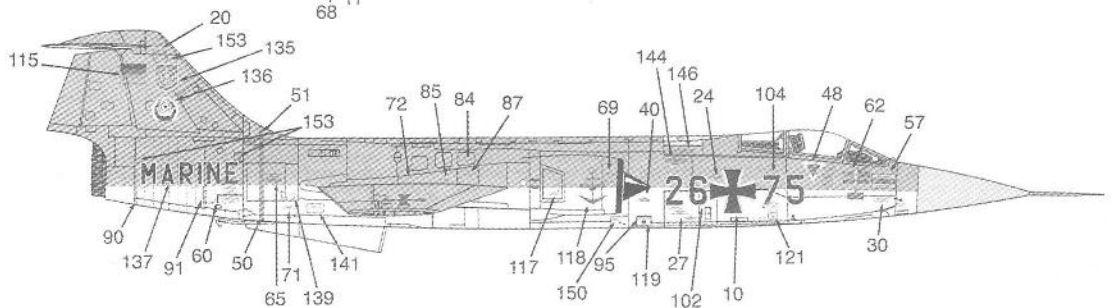
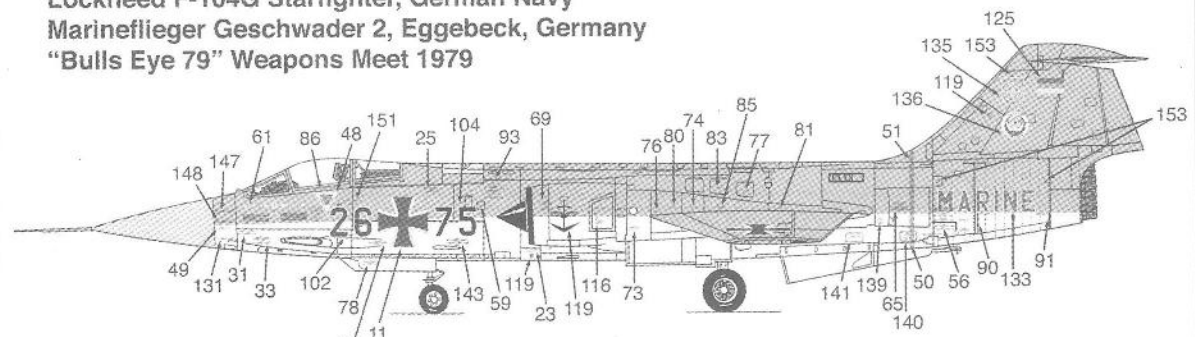

Dieser Bausatz wurde in mehrfachen Qualitäts- und Gewichtskontrollen auf Vollständigkeit überprüft. Reklamationen können nur bearbeitet werden, wenn die Bauanleitung, das aus der Kartonage herausgeschnittene EAN-Strichcode-Feld und der Kassonbon eingeschickt werden. Bitte haben Sie Verständnis dafür, dass wir nur Gewährleistung bei aktuellen Artikeln übernehmen können, die im Zeitraum der letzten 24 Monate erworben worden sind. Unfrei eingesandte Reklamationssendungen werden von uns nicht angenommen!  
„Einzelteile für Umbauten können gegen Vorkasse erworben werden“. Unsere Adresse: Revell GmbH & Co. KG, Abteilung X, Henschelstr. 20-30, 32257 Bünde. Dieser Direktservice gilt für die Länder: Deutschland, Benelux, Österreich, Frankreich, Großbritannien. Reklamationen aus den übrigen Ländern werden über die jeweiligen Distributeure abgewickelt. Bitte kontaktieren Sie Ihren Händler.

This Model Kit has been subject to extensive quality and weight checks during the manufacturing process to ensure it leaves our warehouse in perfect condition. We are only able to process applications for missing parts if the following procedure is followed. In all cases the following will be required before we are able to process any request: Original receipt (proof of purchase) original instruction sheets (will be returned) and the bar code cut out of the box. We may not be able to process requests for products that have been discontinued for more than 24 months. Products that are returned directly to us without prior authorisation by a company representative will not be accepted and returned to sender. Replacement parts for conversion or spares will continue to be available however they will incur a handling charge. Please write to: Department X Revell GmbH & Co. KG, Henschelstr 20-30, 32257 Bünde.

This direct Service is only available in the following markets: Germany, Benelux, Austria, France & Great Britain, Revell GmbH & Co. KG, Boston House, 64-66 Queensway, Hemel Hempstead, Herts, HP2 5HA, Great Britain.  
For all other markets please contact your local dealer or distributor directly.

Afin de vous donner entière satisfaction et pour nous assurer que tous les éléments nécessaires au montage de votre maquette sont présents dans la boîte, cet article a subi dans son intégralité divers contrôles qualitatifs ainsi que des contrôles de poids.

Si toutefois vous deviez nous faire part de certaines réclamations, nous vous prions de bien vouloir vous adresser à votre revendeur habituel, muni de la notice de montage, du code EAN découpé sur la boîte, ainsi que de votre ticket de caisse.

Le SAV ne sera assuré que pour les articles ayant été acquis depuis moins de 24 mois.

Les pièces de rechange utilisées pour la transformation de maquettes pourront être obtenues en pré-paiement. Dans le cas où vous n'obtiendriez pas satisfaction, vous pouvez vous adresser directement à notre service SAV à l'adresse suivante: REVELL GmbH & Co. KG, Abteilung X, Henschelstraße 20-30, D-32257 Bünde ou Revell GmbH & Co. KG, 14 B, rue du Chapeau Rouge, F-21000 Dijon, France.

Pour tous les autres marchés, merci de prendre contact avec votre détaillant ou distributeur.

Deze bouwdoos werd verscheidene malen volledig gecontroleerd op kwaliteit en gewicht. Klachten kunnen slechts in behandeling worden genomen indien de bouwhandleiding, de uit de doos geknipte EAN - streepjescode en de kassonbon zijn meegezonden. Wij vragen om uw begrip dat wij alleen garantie kunnen geven voor huidige artikelen die binnen een periode van de laatste 24 maanden zijn gekocht. Onvolledig ingezonden klachten kunnen niet in behandeling worden genomen. Onderdelen voor ombouw kunnen tegen vooruitbetaling gekocht worden.

Ons adres is: Revell GmbH & Co. KG, Afdeling X, Henschelstrasse 20-30, 322557 Bünde, Duitsland. Deze directe service geldt alleen voor de volgende landen: Duitsland, Benelux, Oostenrijk, Frankrijk, Groot Britannië.

Klachten afkomstig uit overige landen worden via de eventuele lokale vertegenwoordigers van Revell afgewikkeld. Wij verzoeken U contact op te nemen met uw winkelier.