

GERMAN V-1 FIESELER FI103 A-1 FLYING BOMB 1/35 SCALE 德國V-1 FI103 A-1飛彈

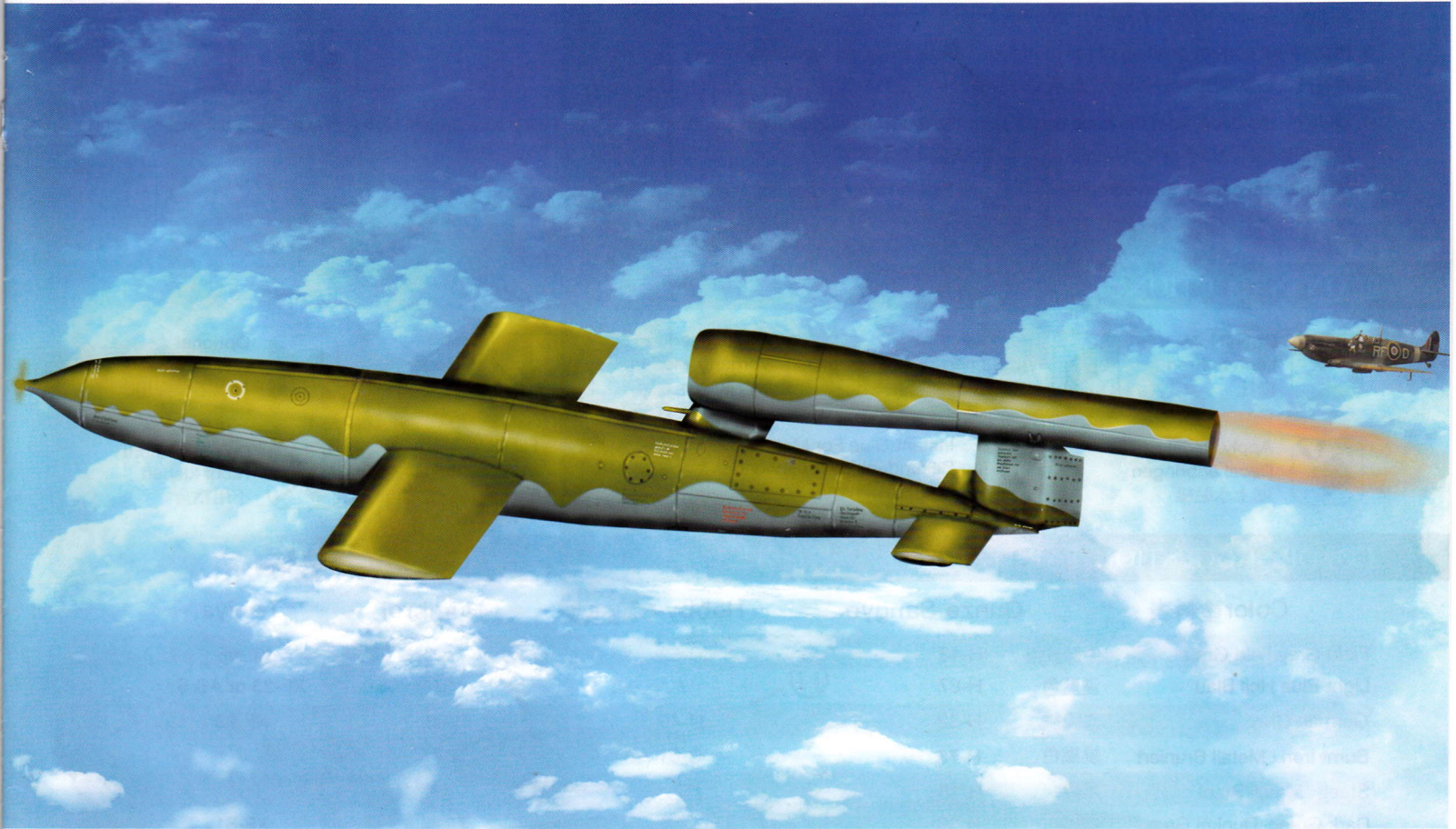

By 1942 the Luftwaffe could no longer bomb England due to RAF air superiority, yet the RAF was able to bomb German cities at will. This led the Germans to develop their Vergeltungswaffe, or vengeance weapons. The first of these was the Fieseler Fi-103, a small jet powered flying bomb developed in 1943 and ready for service in mid-1944. The V-1 was normally launched by a steam catapult from a fixed firing ramp, but as the launch sites were overrun by ground forces, some were air launched from Heinkel He111 bombers. The V-1 carried an 850kg warhead to a maximum range of 250 kilometers at a speed of 630 km/h. The first weapons were launched against London in June 1944, a few days after the Allied D-Day landings in France. Over 10,500 V-1's were launched during the war, but of these only about 2,500 hit their targets, the rest were intercepted or crashed due to mechanical failure.

Information by Philip Greenwood

Aufgrund der britischen Luftüberlegenheit konnte die deutsche Luftwaffe ab 1942 England kaum noch bombardieren, während im Gegenzug die RAF über Deutschland ziemlich freie Hand hatte. Dieses brachte die Ingenieure 1943 auf die Idee zur Entwicklung der Fieseler Fi-103, einer relativ kleinen Düsenangetriebenen Flügelbombe, welche dann ab Mitte 1944 eingesetzt wurde. Der als V-1 (V=Vergeltungswaffe) bekannte Marschflugkörper wurde von Dampfgetriebenen Katapulten gestartet. Nachdem diese von alliierten Bodentruppen überrannt wurden, benutzte man HE-111 Bomber als „Starthilfe“. Die V-1 trug einen 850 kg schweren Sprengkopf mit knapp 600 km/h bis zu 250 km weit. Im Juni 1944, kurz nach den Landungen in der Normandie, gingen die ersten V-1 in London nieder. Von den hergestellten 10500 Stück trafen ca. 2500 das jeweils vorgegebene Zielgebiet, welches ein Radius von 12 km hatte. Nachdem die Japaner die Pläne der V-1 erhalten hatten, bauten sie eine eigene bemannte Version, welche jedoch bis Kriegsende nicht einsatzbereit war.

© Translation Michael Knoblich Academy Europe

V-1(Fi103)飛彈是世界上第一種巡航式導彈。德軍將V-1飛彈發射陣地集中建在朝向英國的法國海岸。1944年6月13日德軍V-1飛彈發射部隊開始向英國本土發動了攻擊。至同年9月4日，德軍向英國東南部地區共發射了8600多枚V-1導彈，其中射向倫敦的約5000枚，但真正打到倫敦的不到一半。而且大多數飛彈造成的傷亡不大，只有少數飛彈打到了人口密集區才造成較嚴重傷亡和損失。直至1945年的1月初，對英國目標發射的飛彈總數達10,500枚左右。

ILLUSTRATION 圖示說明:

CORRECT METHOD FOR APPLYING DECALS : HINWEISE ZUM ANBRINGEN DER DECALS :

正確使用水貼紙的方法:

1. Clean model parts surface with wet cloth. Entsprechende Stellen am Modell feucht reinigen.
將需要貼上水貼之部位表面擦乾淨。
2. Cut out the decal parts and dip them in cold water for 15 ~20 seconds. Decal ausschneiden und für 15-20 Sek. ins Wasser legen.
將所需之貼紙剪下泡在清水裏約15至20秒。
3. Place it on correct position of the model kit. Decal an der richtigen Stelle aufgen.
將濕透之貼紙取出置放於正確之位置旁。
4. Slide off the decal from the base paper on to the model kit surface with a cotton stick. Decal mit Wattestäbchen festhalten und Papier darunter wegziehen.
用棉花棒輕輕推貼紙表面使其從底紙滑出至模型表面之正確位置。
5. When decal get dry then complete. Decal mit Papiertuch andrücken und trocknen.
待其自然乾透後即完成。

ICON INSTRUCTION: 圖標說明:



Open Hole
Loch bohren
鑽孔



Remove
Abtrennen
切除



2 Sets needed
Vorgang wiederholen
同樣的製作二組



Bend
Biegen
曲折



Optional
Auswahl
可以選擇採用



Apply Decal
Decal anbringen
貼上水貼紙



Instant Glue For Metal
Sekundenkleber verwenden
瞬間接著劑, 金屬用



Fill Hole
Verspachteln
把孔填平



Do not cement
Nicht kleben
不用粘合

COLOR SUGGESTION: FARBTABELLE: 塗裝指引:

Color塗料表	Gunze Sangyo	Hobby Color	Humbrol	Tamiya
Field Grey Feld Grau	原野灰色 H-48	C-52	/	XF-65
Light Blue Hell Blau	淺藍色 H-67	/	/	XF-23 or AS-5
German Grey	德國灰 H-32	C-40	92	XF-63
Burnt Iron Metall Bruniert	燒鐵色 H-76	C-61	/	/
Steel Metall Stahl	黑鐵 H-18	C-28	53	/
Dark Green Dunkel Grün	深綠 H-36	C-17	30	XF-61
Tire Black Reifen Schwarz	輪軸黑 H-77	C-137	85	XF-1

READ BEFORE ASSEMBLING: VOR ZUSAMMENBAU LESEN: 組裝必讀:

- Carefully Study instruction before assembling. Anleitung studieren und verständlich machen. 組裝前請閱讀清楚製作指引。
- Keep plastic model glue and tools away from children. Kleber, Farben, Werkzeuge und Plastiktüten von Kindern fernhalten. 膠水, 油漆及工具勿讓小孩接觸。
- Do not use cement or paint near open flame or sparks. Kleber/Farbe nicht in Nähe von offenen Flammen. 膠水及油漆勿接觸火種。
- Do not work in closed room. Nur in ausreichend belüfteten Räumen arbeiten. 勿在密封地方製作模型。



Copyright©2008
 Made in China
 中國製造

Ⓑx1

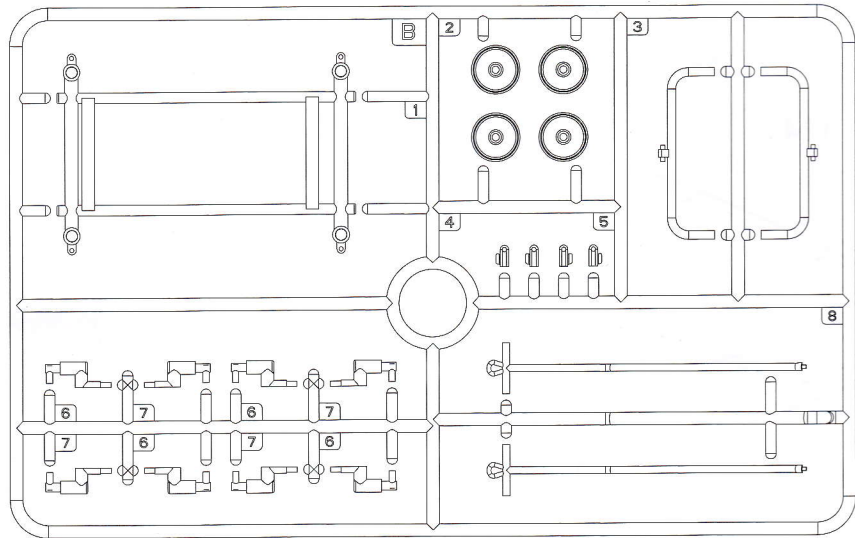

Ⓔx1

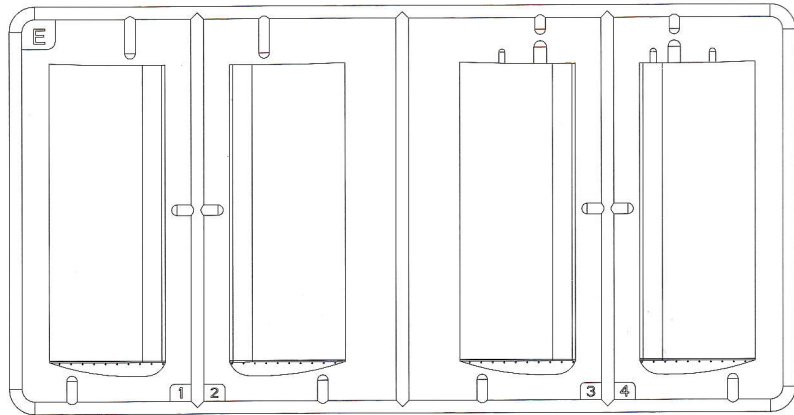

Ⓐx1

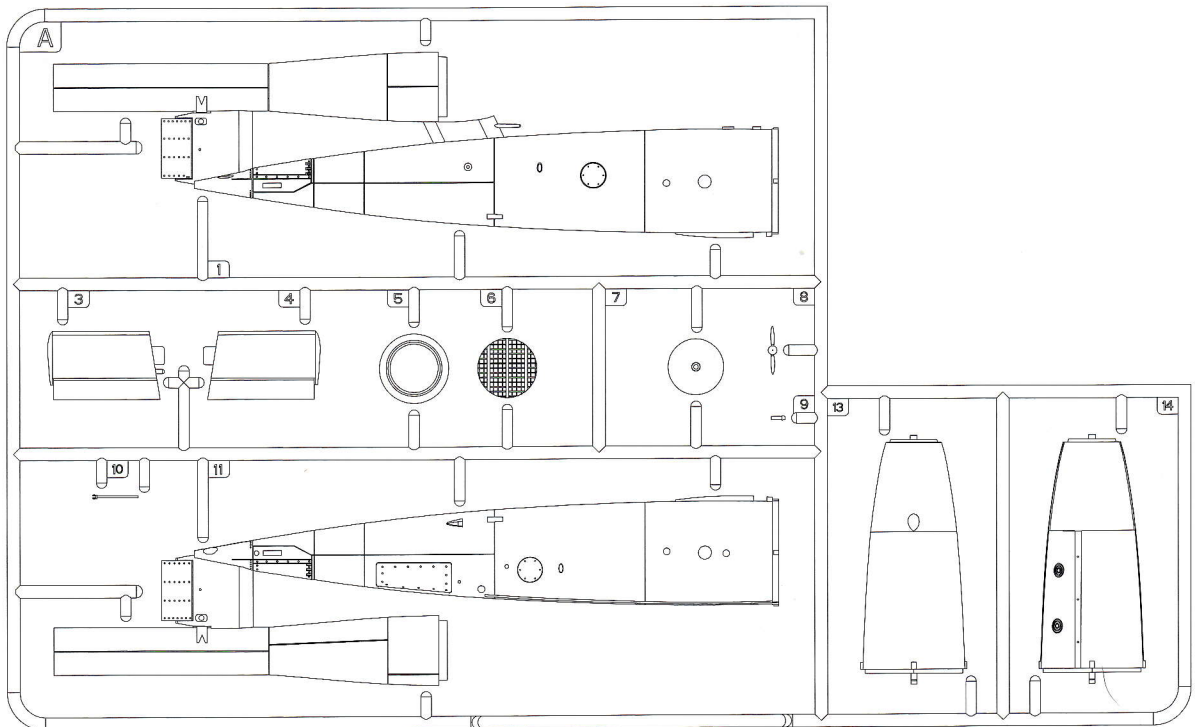

ILLUSTRATION 圖示說明:

1

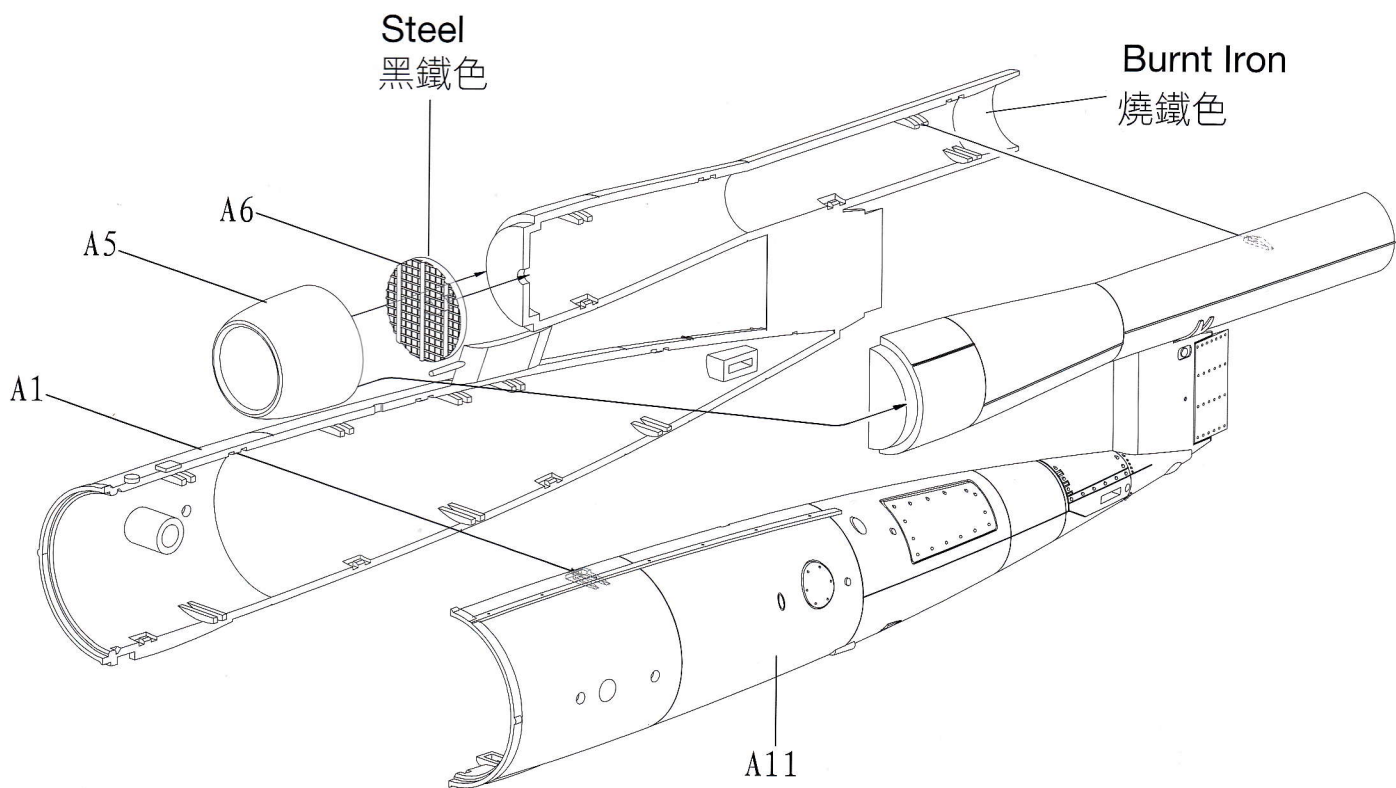
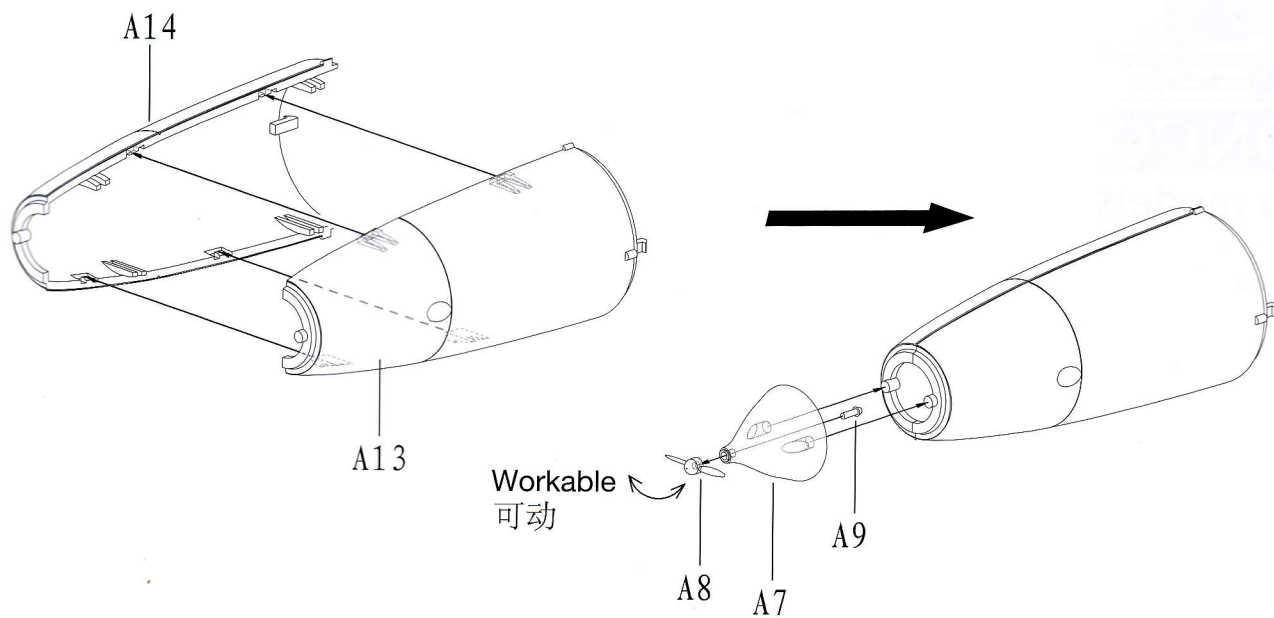
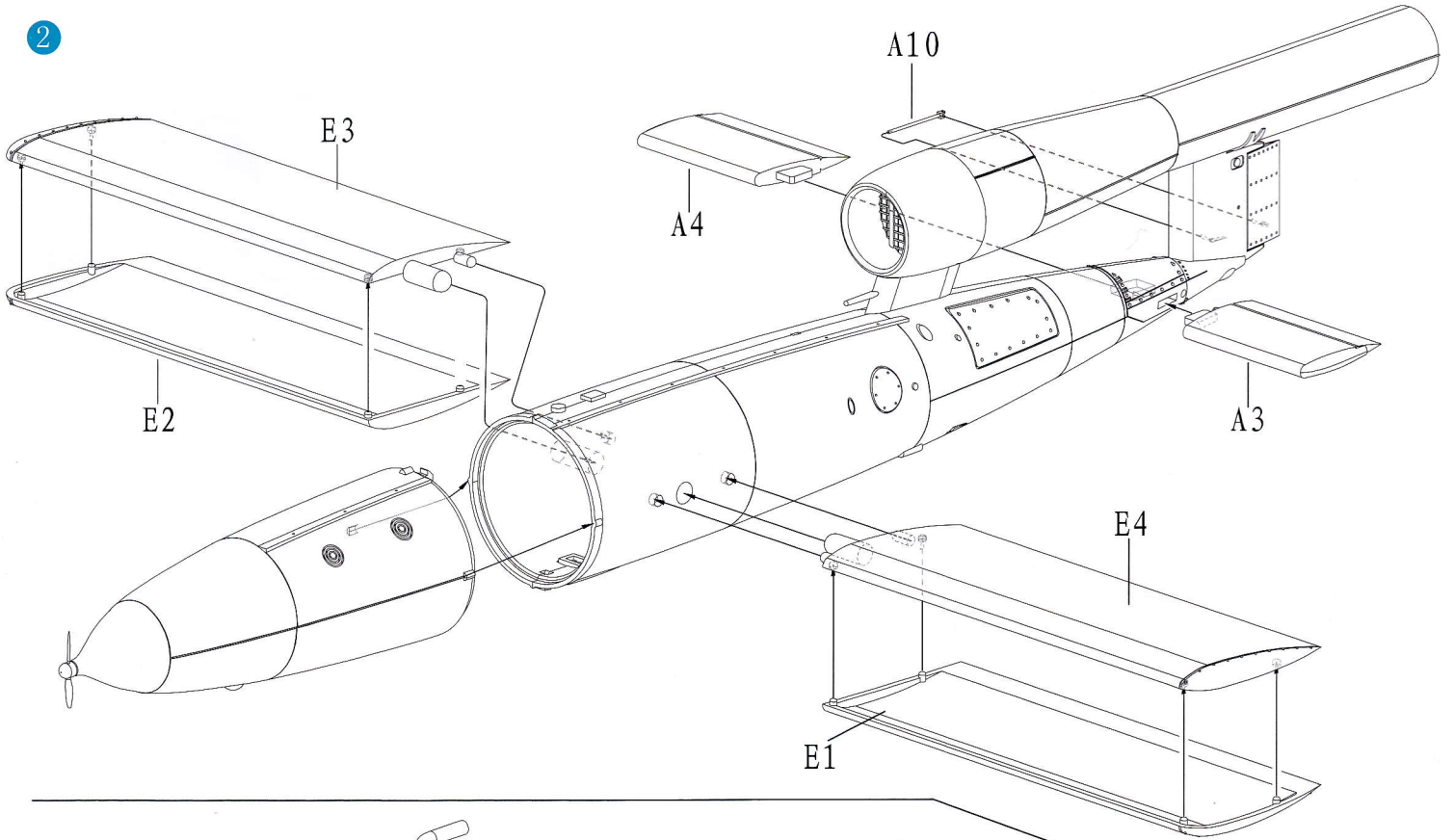
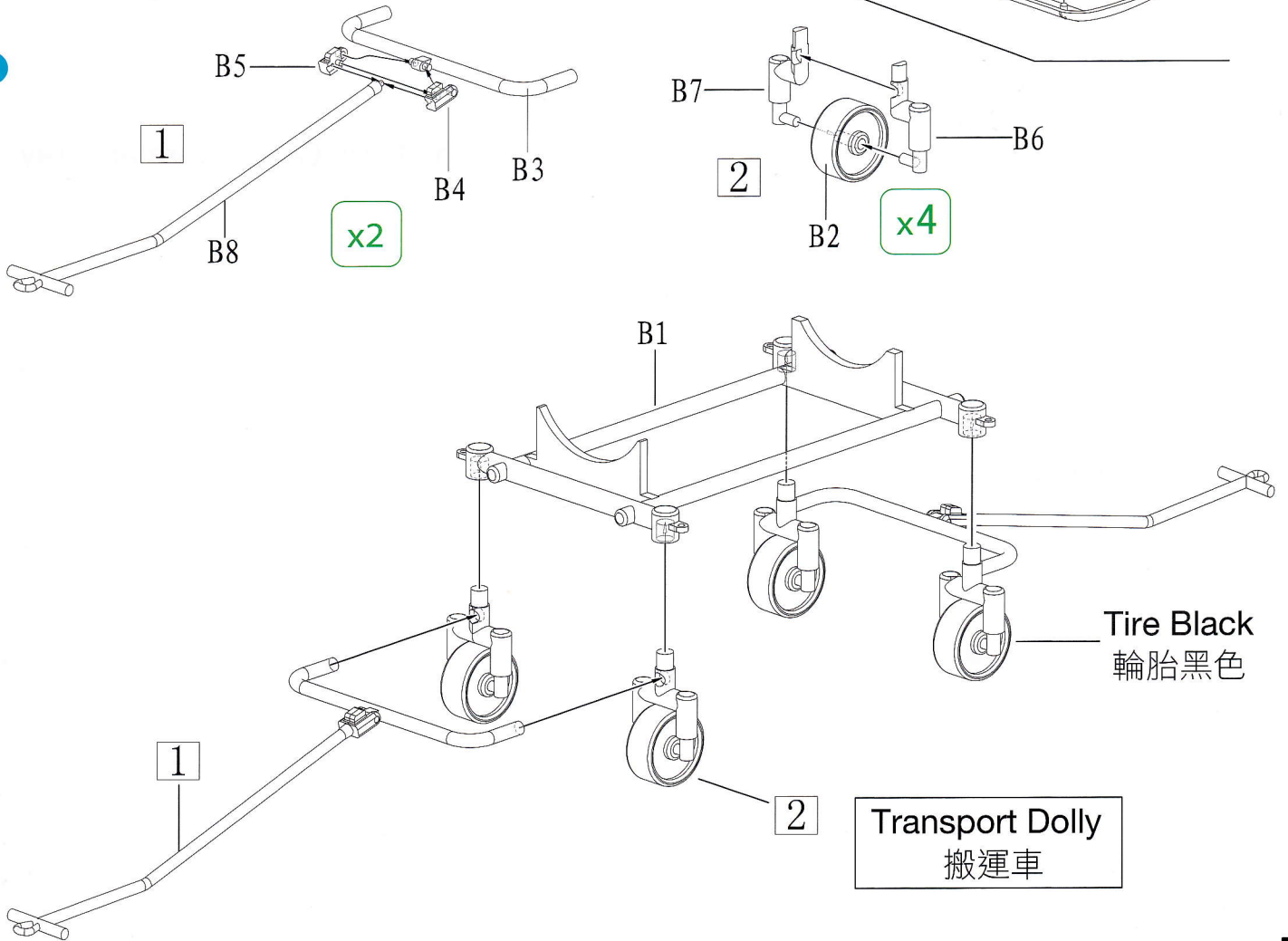

ILLUSTRATION 圖示說明:

2



3



4

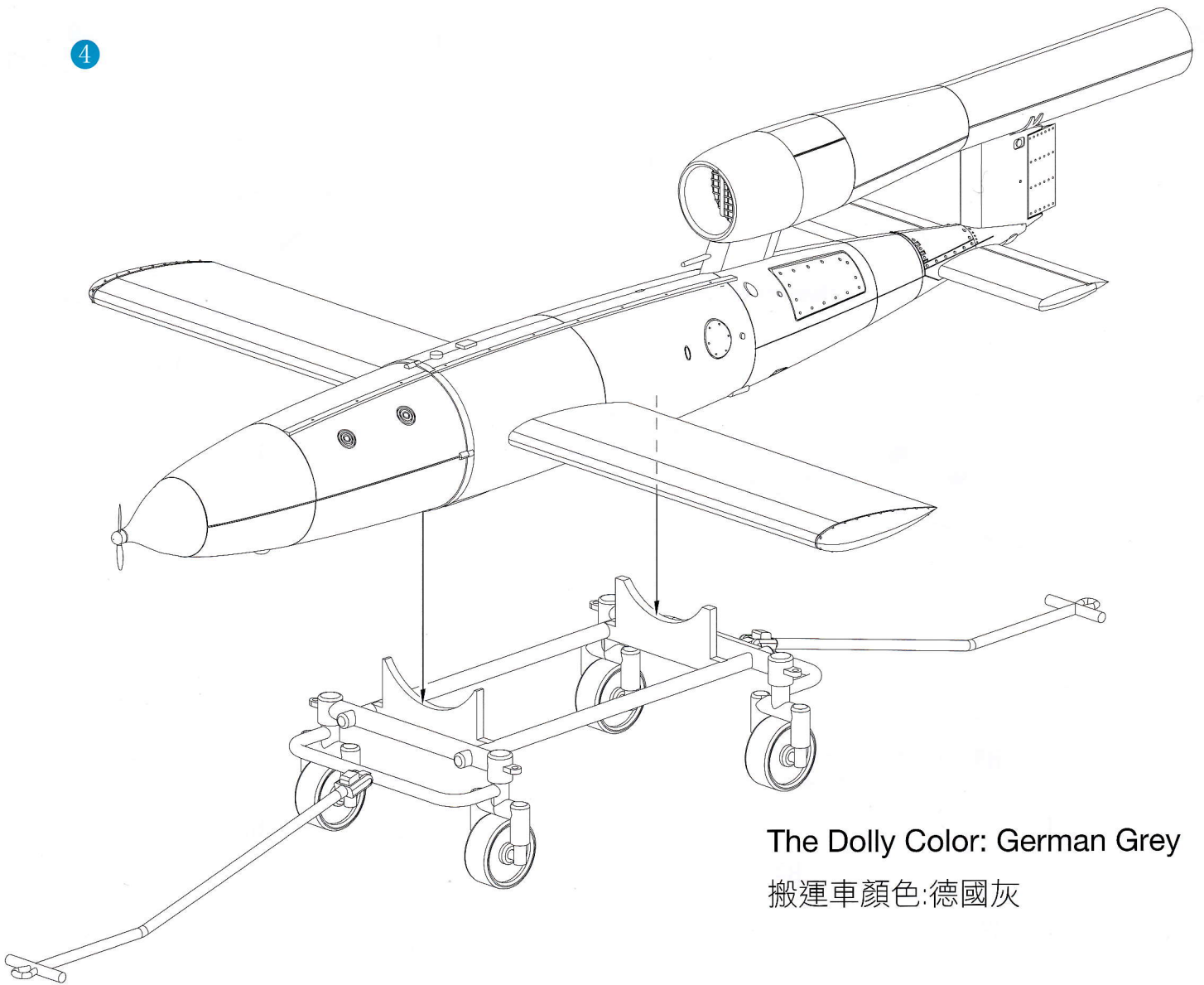

The Dolly Color: German Grey
搬運車顏色:德國灰

Decal Guide 水貼指引

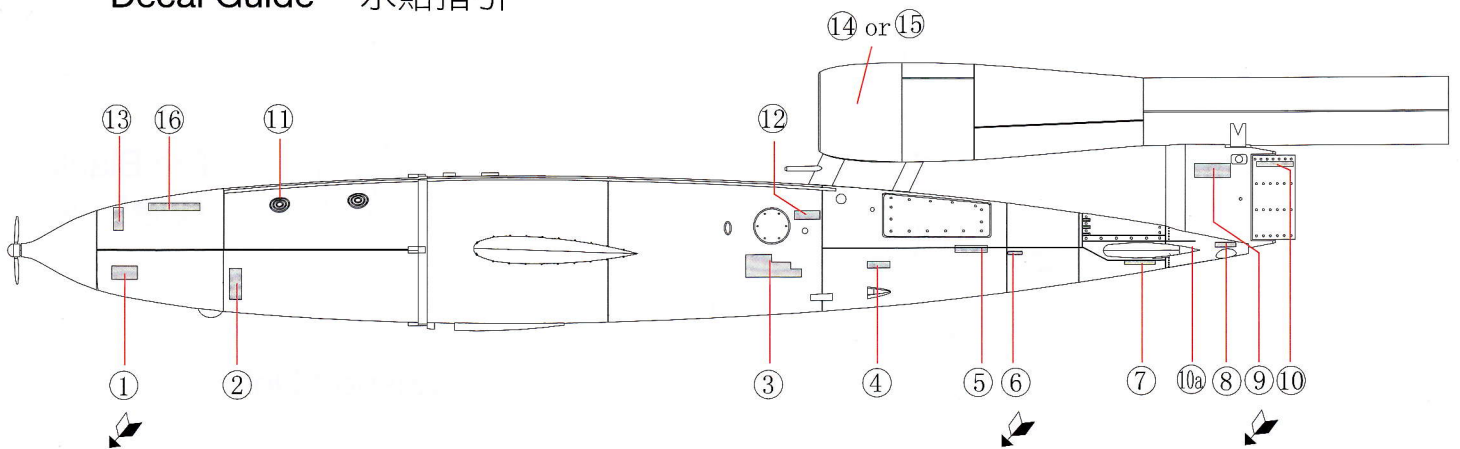

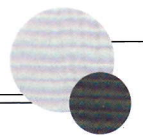

Option 1:

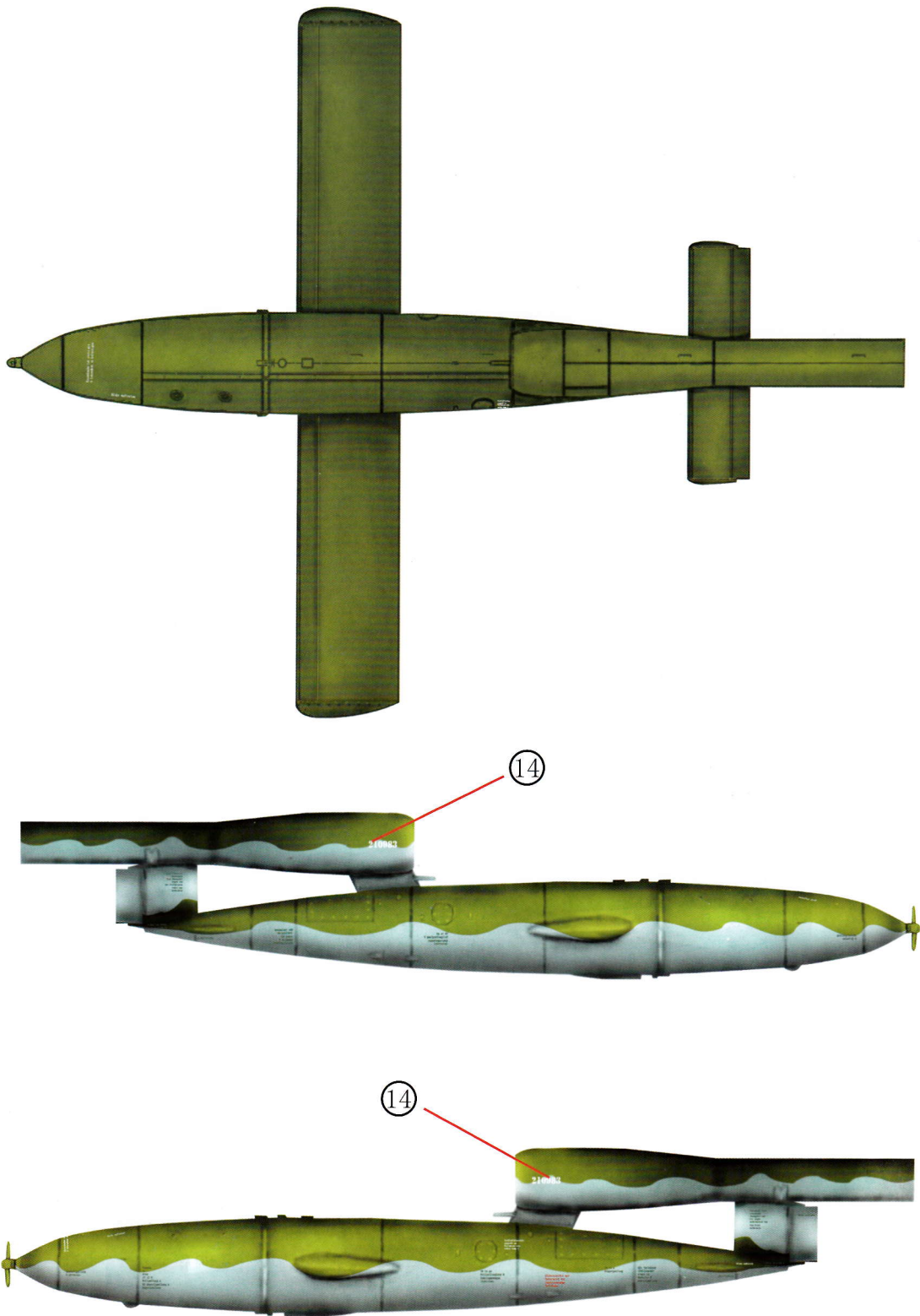

Camouflage Scheme: Upper Surface(Dark Green)
Under Surface(Light Blue)

迷彩顏色: 上半部深綠色;下半部淺藍色

Option 2 :

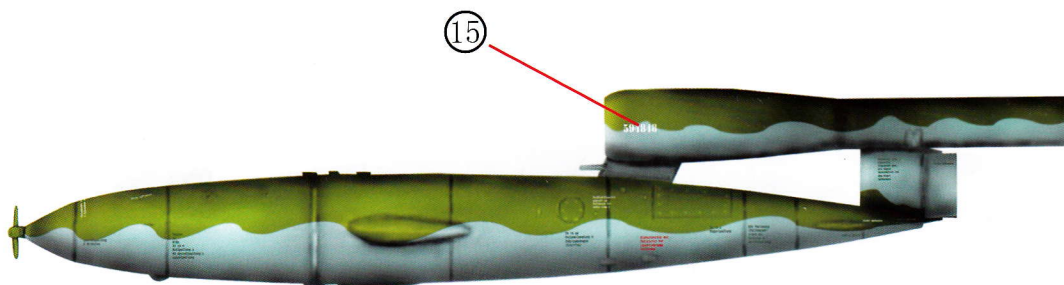
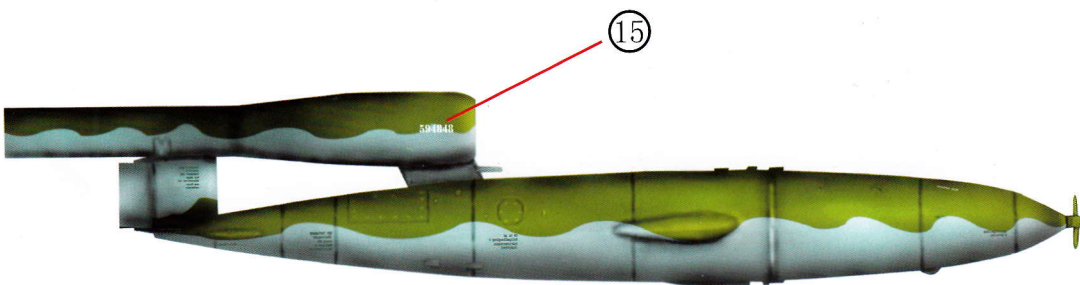
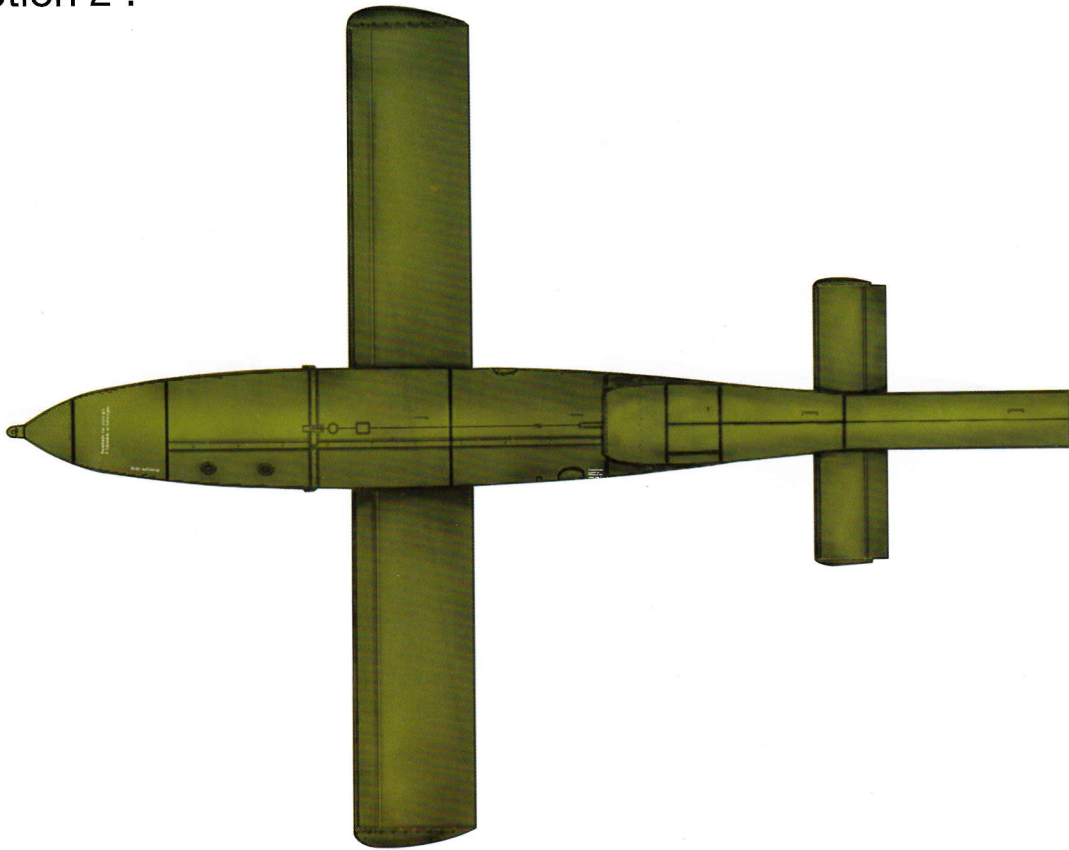

Camouflage Scheme: Upper Surface(Dark Green)
Under Surface(Light Blue)

迷彩顏色: 上半部深綠色;下半部淺藍色