



M-18 HELLCAT TANK DESTROYER

M18地獄貓驅逐戰車



M18 Hellcat

"Bitch" is the nick name given by the U.S. soldiers to the M18 Hellcat, the tank that had great impact on the development of tank design of the U.S.

M18 was designed by Buick Motor car Division of General Motors Corporation in 1943. A total of 2,507 tanks were built up until 1944. Other variations include the M39 armor tow vehicle. The most notable point of the M18 was its first use of torsion bar suspension among U.S. tanks, a total departure from any design used, setting a new milestone for the U.S. tank development. The M18 is equipped with a 76cm M1A1 high velocity anti-tank gun packing it with the ability for rapid firing and excellent armor penetration making the M18 among the best in terms of fire power among the Allied Forces. Its extraordinary high mobility was also a new break through to the stereotype that tanks were "Slow and Clumsy", The excellent performance of the M18 gave great inspirations for engineers for future development of battle tanks. M18 was one of the very few Allied tanks which can equal the often superior German tanks during the war.

In World War II, M18 was deployed in the Tank Destroyer battalion and was used side by side with the much heavier M10 and M36. Among them, the tank destroyer battalion of general Patton was the most famous. It had a great deal of contribution to European battle field.

M18 data: Length/Width/ Height: 6.65/2.87/2.56M Armament: 76cm M1A1C/ M1A2 high velocity anti-tank gun
 Weapon elevation: +20 to -10 degrees Machine guns: 12.7mm heavy barrel machine gun w/800 rounds
 Ammo Storage: 45 rounds Engine: Continental R-975-C4 Star 9 cylinder air cool engine Crew: 5
 Horse power: 400HP Fuel storage: 170gallons/680 liters Speed: 72km/hr Climbing rate: 60%
 Weight: 18 tons with full stores

M18 地獄貓驅逐戰車

“潑婦”是美軍士兵對 M18 Hellcat 的俗稱，而它深深的影響了美軍戰車發展史。

M18 為美國別克汽車公司於 1943 年設計製造的，至 1944 年為止共生產了 2,507 輛，另有衍生型 M39 裝甲運輸車。M18 最大的特色是美軍履帶車中第一個採用扭力桿懸吊系統的車輛，在拋棄了以往舊有設計概念，使得美軍戰車發展史邁向另一個新的里程碑。本車的優異性除採用新懸吊系統外，在火炮方面是使用 76 公厘 M1A1 型高射速反戰車砲，其具備了快速射擊及強力穿甲功能，也是同盟軍中火力優異的火炮系統之一，而更難得的是擁有高速行駛的能力，突破眾人對戰車“慢與遲頓”的概念，使得許多工程師在設計未來履帶車助益不少，而且 M18 也是少數能與德軍優秀戰車匹敵的同盟軍戰車。

M18 在第二次世界大戰時，被美軍的裝甲師特別編列在專屬的驅逐戰車營中，同時它與 M10 及 M36 型驅逐戰車一齊被部隊指揮官當成反戰車的王牌來運用，並與盟軍協同作戰，其中又以巴頓將軍的驅逐戰車營最富盛名。中華民國陸軍在民國 41 年起開始獲得美軍軍援此車，總共接獲了 214 輛，同時被編列在裝甲騎兵團及裝甲騎兵營中，隨後海軍陸戰隊也接收了部份陸軍裝備其中也包含了 M18，直到民國 74 年才完全除役。

M-18 性能諸元: 車長/寬/高: 6.65/2.87/2.56 公尺 主武裝: 76 公厘 M1A1C 或 M1A2 型高射速反戰車砲,
 火炮仰角/俯角: +20 度至 -10 度 攜彈量: 45 枚 副武裝: 12.7 公厘重管機槍
 攜彈量 800 發 引擎: 大陸 R-975-C4 星型空冷九汽缸引擎, 400 馬力
 攜油量: 170 加侖 (680 公升) 乘員: 5 員 車速: 每小時 72 公里 戰鬥重量: 18 噸

M18 ヘルキャット

1943年、ジェネラル・モータースのビエイック部門で製造されたM18はアメリカの戦車の中で初めてトーション・バーサスペンションを使用、成功させたことによって、その後のアメリカ戦車のデザインに大きな影響を与えたことで知られています。1944年までに全部で2507両が製造され、バリエーションとしてM39装甲牽引車等があります。

M18は射撃速度の速い76mm M1A1戦車砲を備え、高速機動力の高さとあいまって連合軍のそれまでの「のろくてうるさい」といわれた戦車に対する見方を変えたときと言えます。このため、前線の兵士達から畏敬の念を込めてビッチ（雄犬、もしくはあばずれ女の意）とあだ名され、優秀なドイツ軍と互角に戦ったといわれています。

M18は第二次大戦では対戦車大隊に所属し、はるかに大型のM10、M36と肩を並べて戦いましたが、戦闘力において決してひけを取らなかったといわれ、ヨーロッパでの勝利に大きく貢献し、パットンが率いた対戦車大隊が特に有名です。

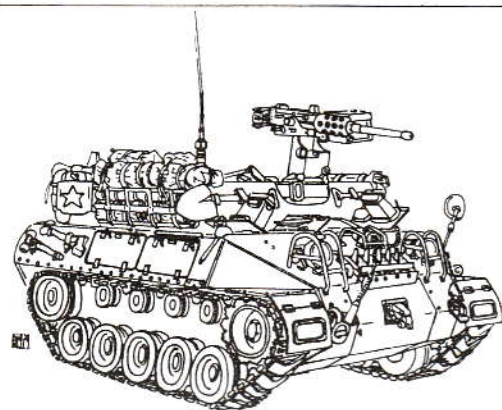

テータ	6.65/2.87/2.56
車体寸法	5
重量	76mm M1A1C/M1A2 対戦車砲
武装	45
発射弾数	+20~-10度
主砲仰角	1.7mm 機関銃/RD0発
機関銃	9気筒空冷星形
エンジン	コンチネンタルR-975-C4
馬力	400HP
燃料タンク容量	680リットル
最高速度	72キロ/時
戦闘重量	18トン
登坂能力	60% (30度)

Illustration : 圖示説明



AGGLUTINATE
用膠黏合



NO AGGLUTINATE
不用黏合



MAKE 2 SETS
二組製作



CUT OFF
切除



OPTIONAL
選擇使用



APPLY DECAL
貼上貼紙



PAINTING
塗裝



NOTICE
注意

Method for applying decals :



1. Clean model surface with wet cloth.
2. Cut out of decal sheet and dip them in water for 15 seconds .
3. Place it on proper position on model .
4. Slide off base paper leaving decals on model with wet finger tip .
5. Move decals to exact position , push out excess water under decal with soft cotton cloth .
6. When decals get dry then complete .

水貼紙製作説明:

1. 將模型表面擦乾淨
2. 將貼紙剪下泡入清水中約 15 秒
3. 將泡濕之貼紙取出置於欲貼處旁
4. 用指尖輕推貼紙表面使其滑出底紙
5. 將貼紙調整至適當位置並輕擦拭水份
6. 待其自然乾燥後即完成

Color list: 塗料表

Color	Brand	Gunze			Humbrol	Revell
		Hobby Color	Mr.Color	Mr.Color Spray		
Red	紅	H-3	C-3	J-3	19	31
Steel	黑鐵	H-18	C-28	J-28	53	91
Tire Black	輪胎黑	H-77				
Brass	黃銅		C-219		54	92
Flat Black	消光黑	H-12	C-33	J-33	33	302
Flat White	消光黑	H-11	C-62	J-62	34	301
Olive Green	橄欖綠		C-120		172	361
Bright blue	寶藍	H-15	C-65	J-65	14	150
Olive Drab(2)	橄欖綠(2)	H-78	C-22		66	46
Silver	銀	H-8	C-8	J-8	11	90
Tan	皮革	H-27	C-44	J-44	118	88
Red Brown	紅褐	H-47	C-41		160	383

1

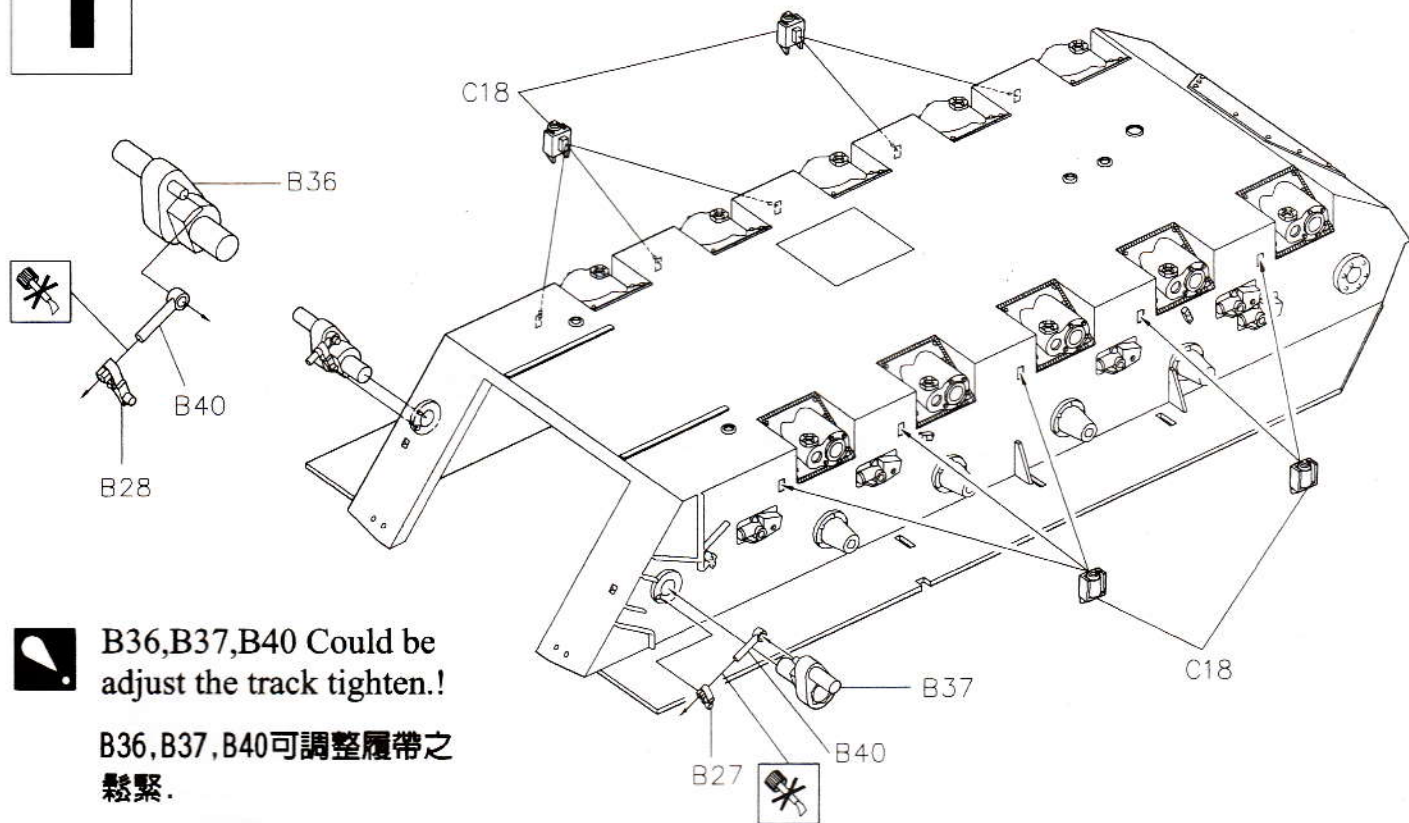

B36,B37,B40 Could be adjust the track tighten.!

B36,B37,B40可調整履帶之鬆緊。

2



Notice: The direction of cut!
注意切除方向。

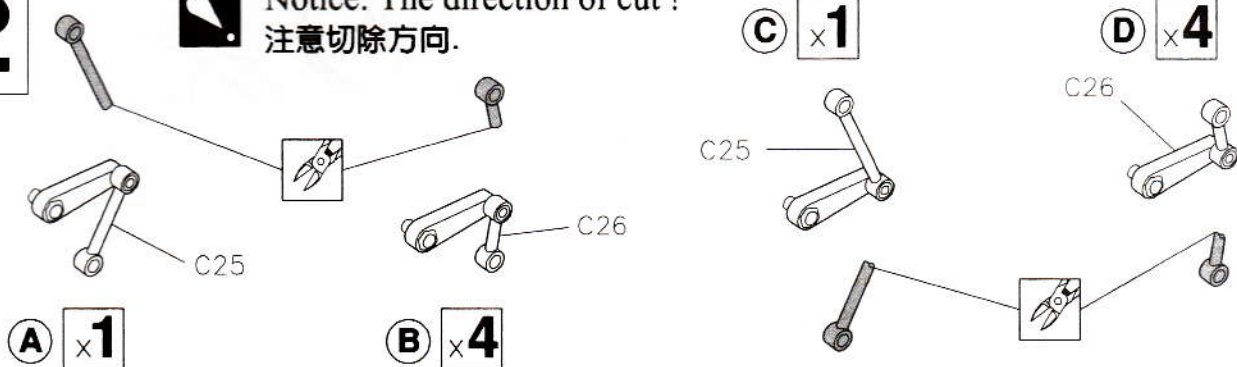

3

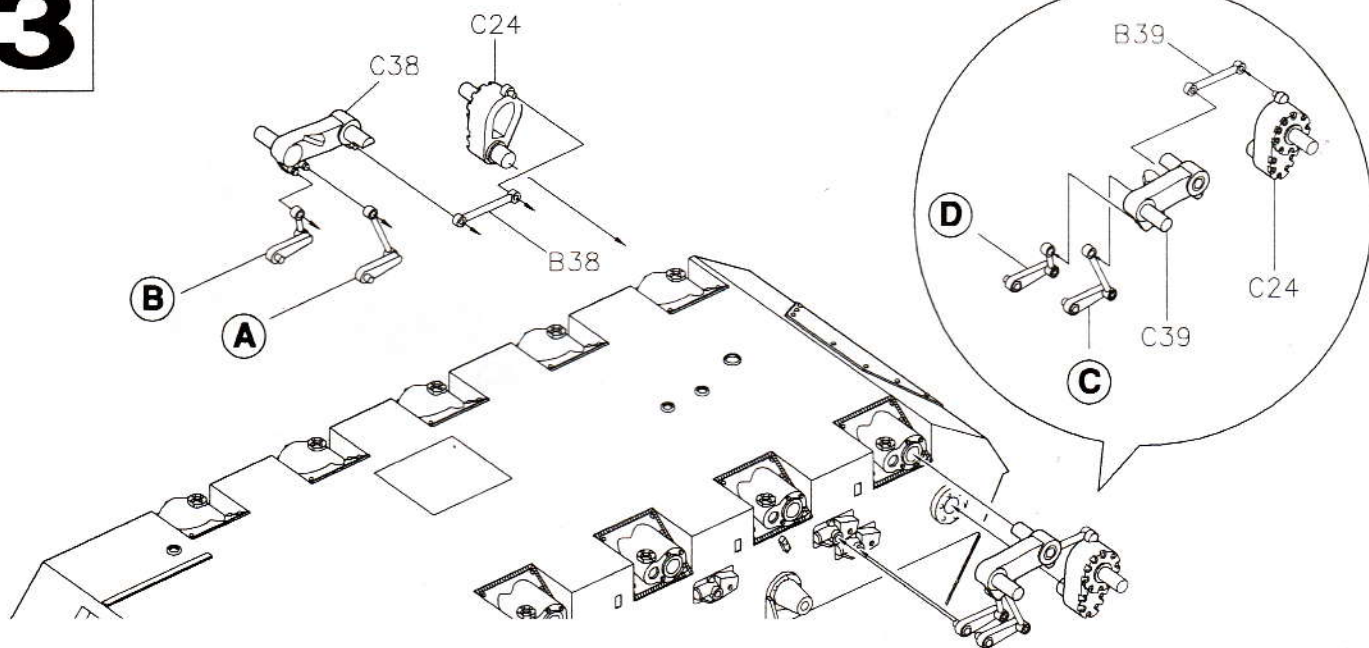

4

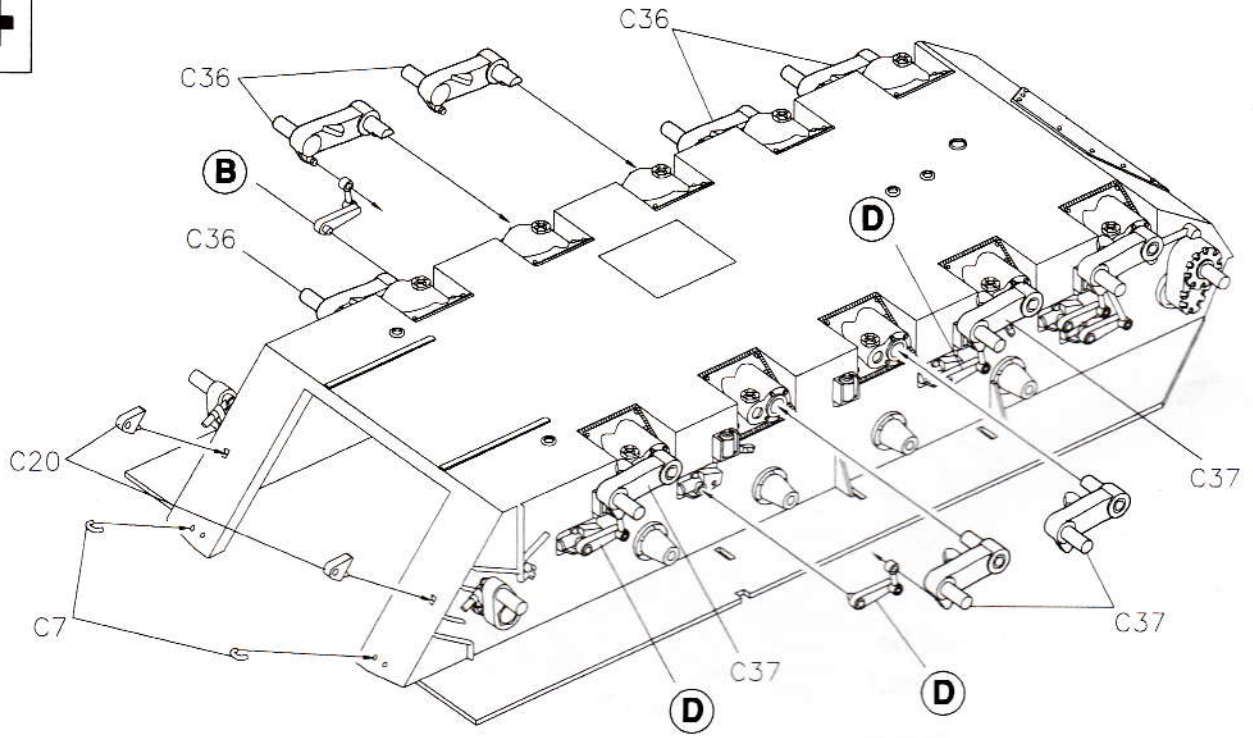

5

[Tire black]

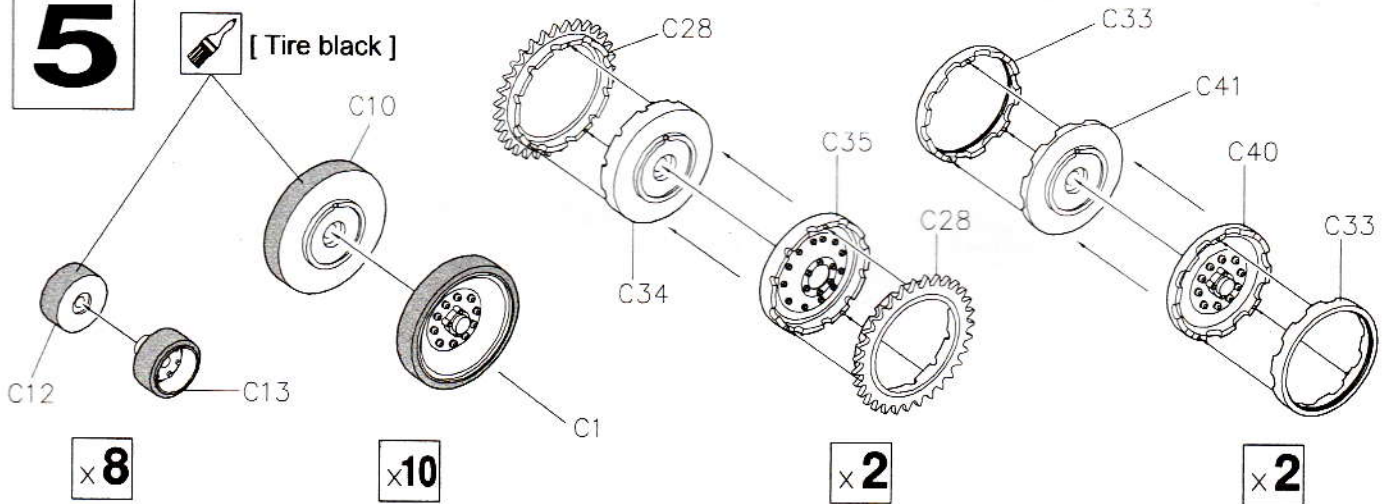

6

[Steel]

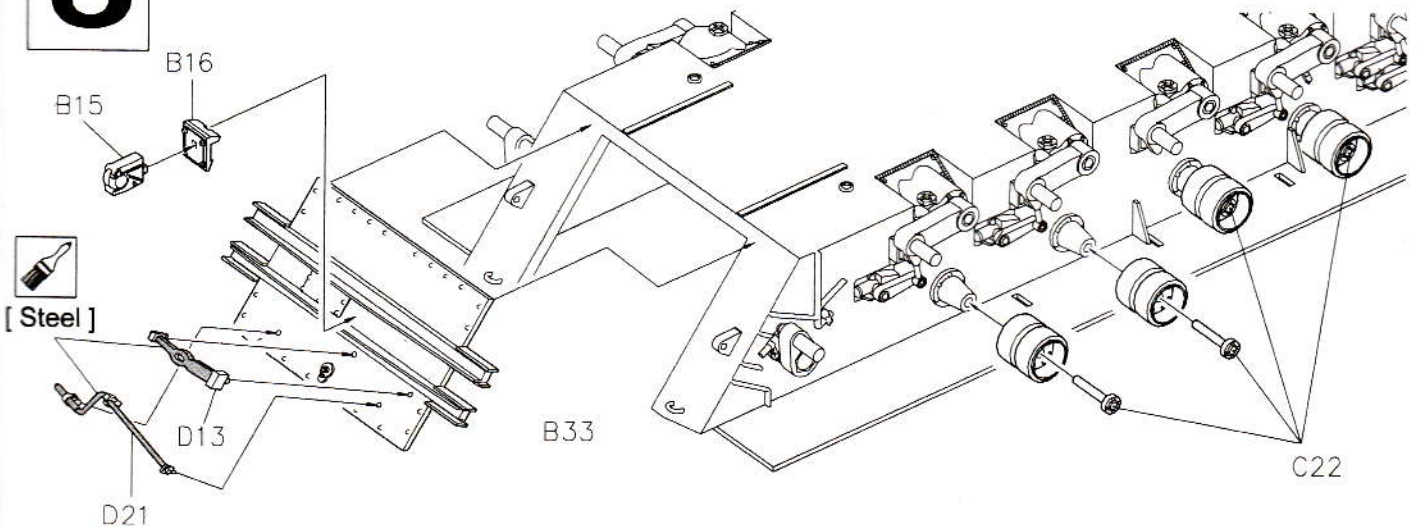

7



x4

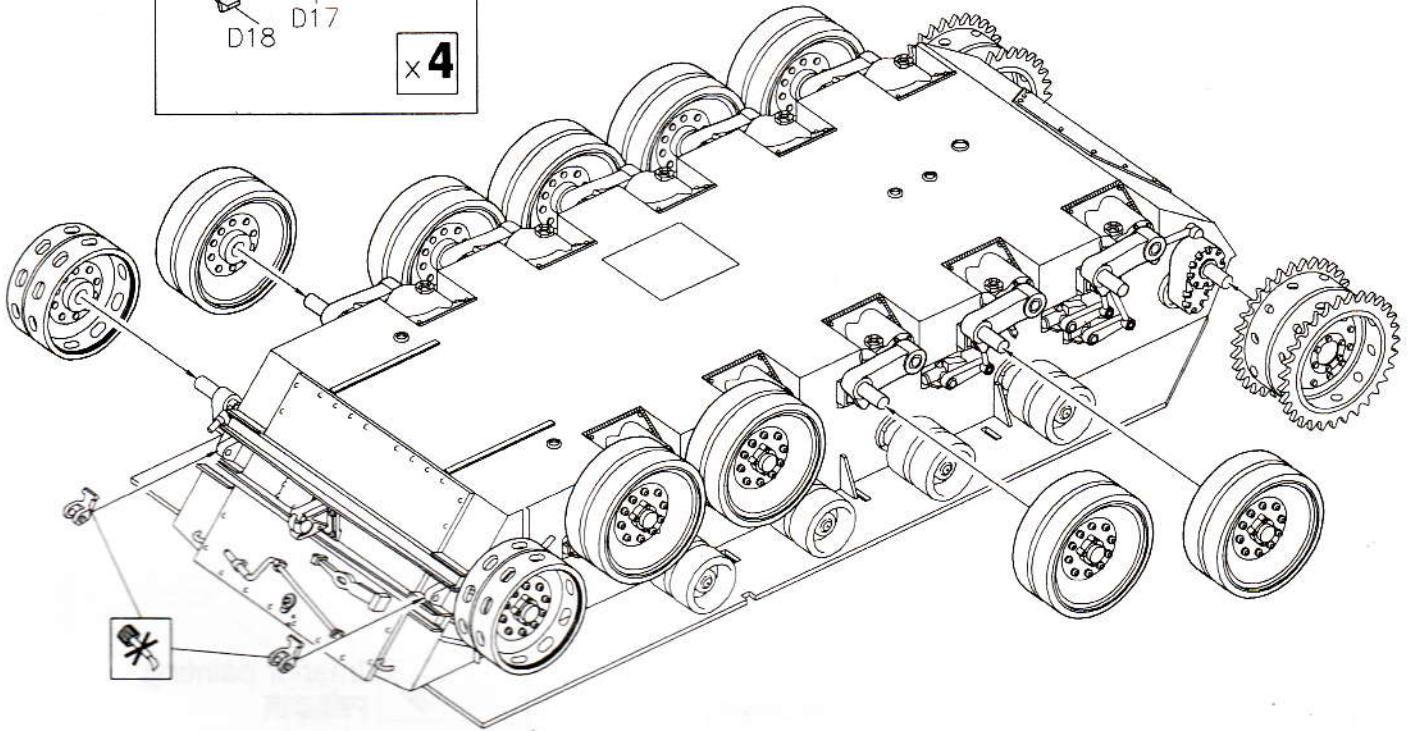

8

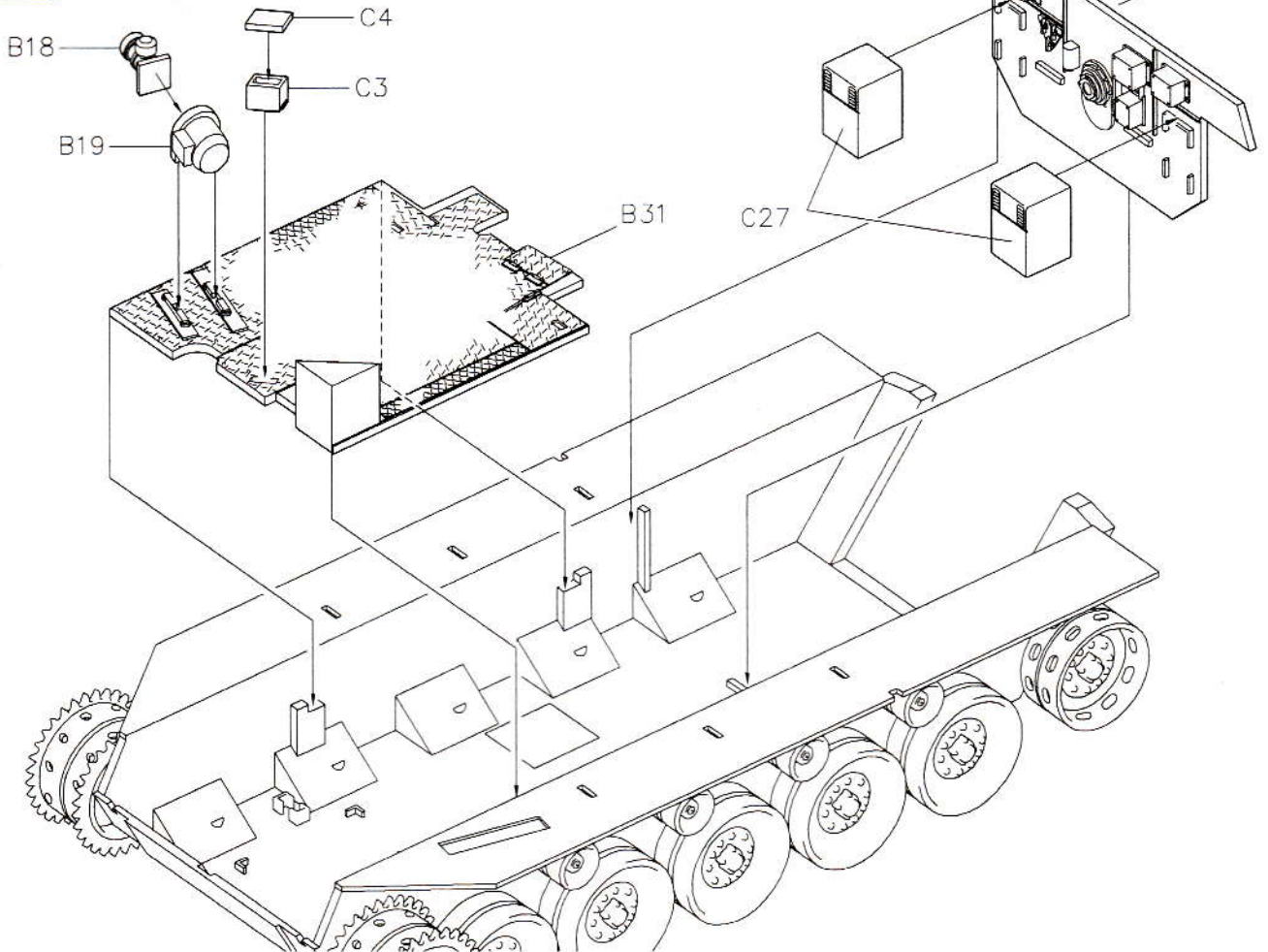

9

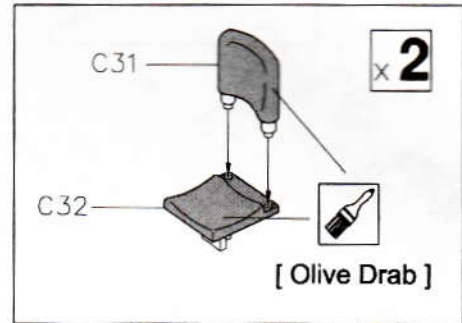
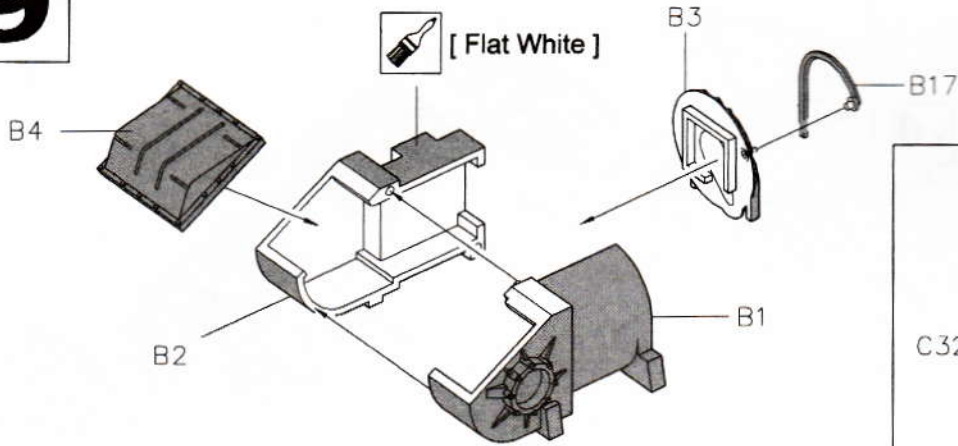

10

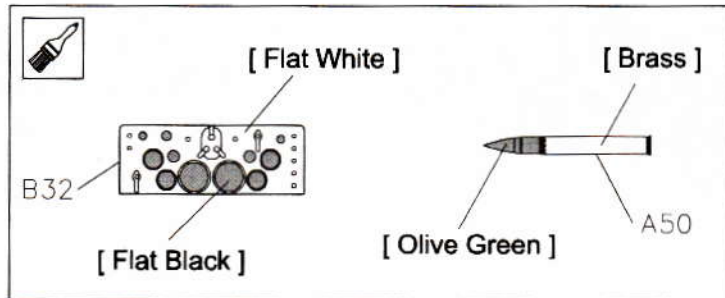

 Interior painting:
内部塗装
[Flat White] or [Olive Drab]

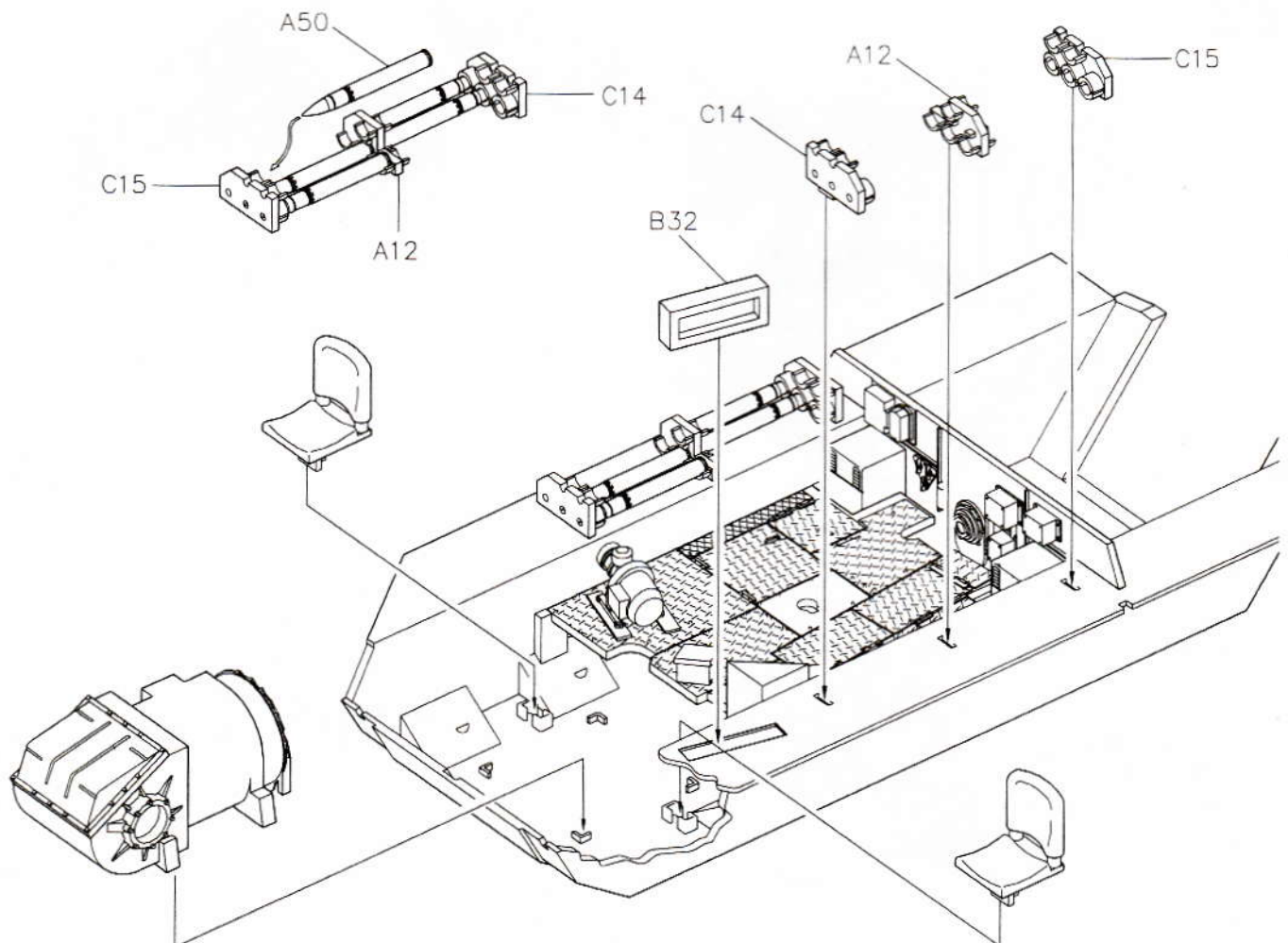

11



Reference position of assembly.
組裝參考.

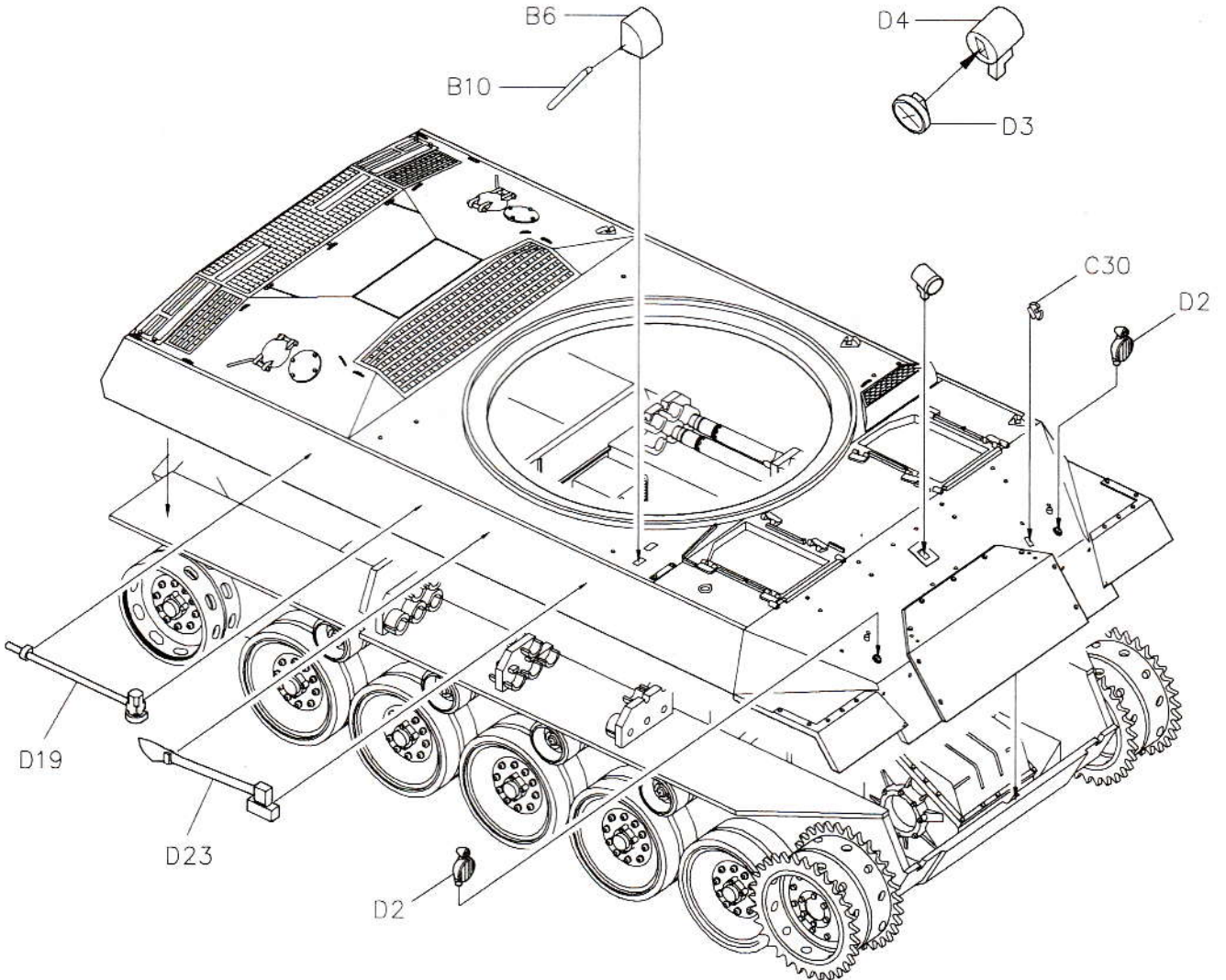
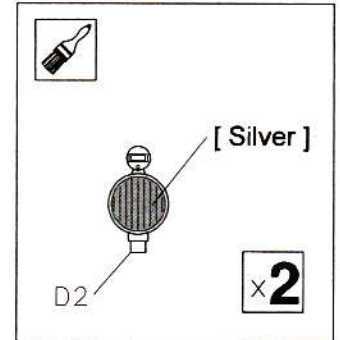
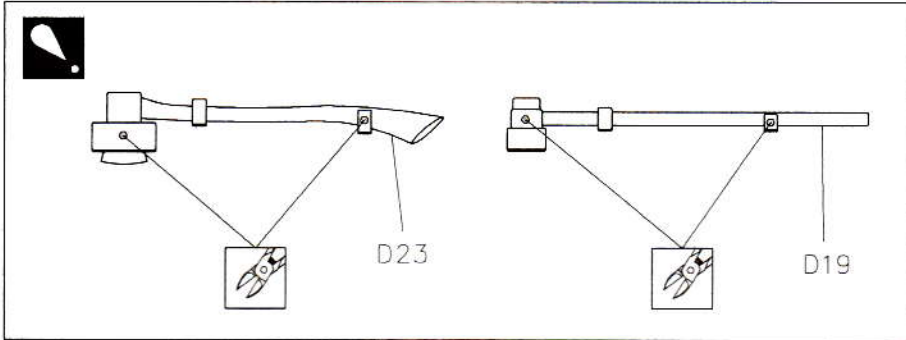
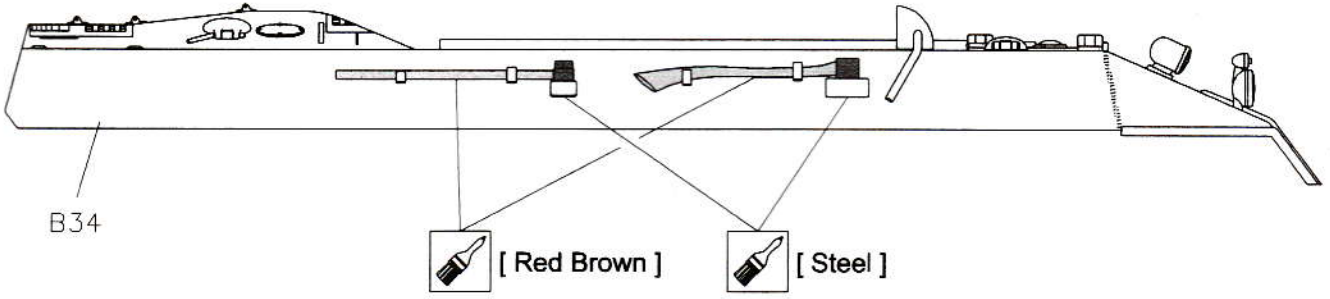

12



Reference position of assembly.
組裝參考.

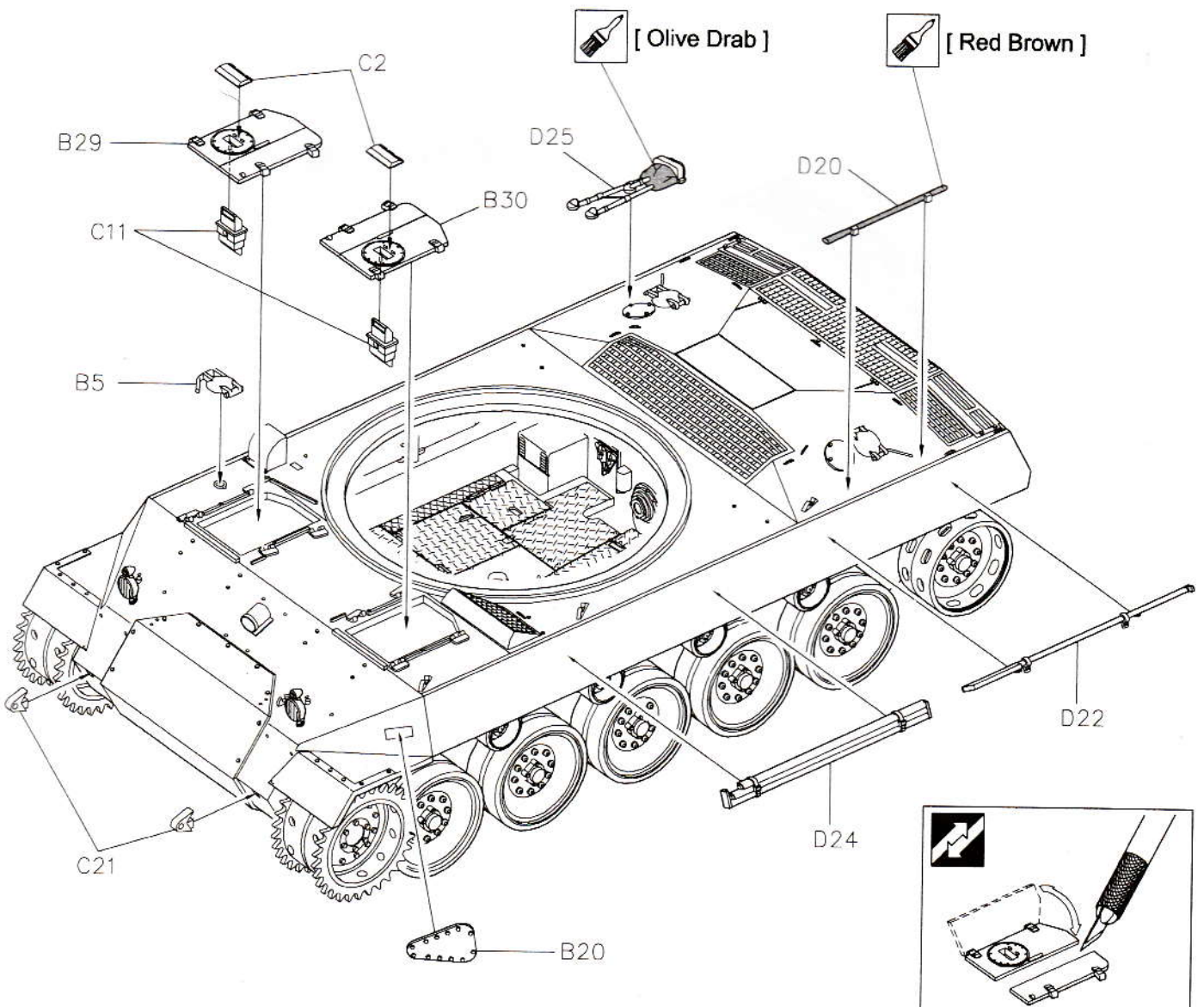
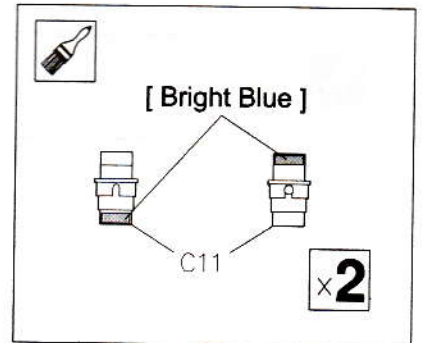
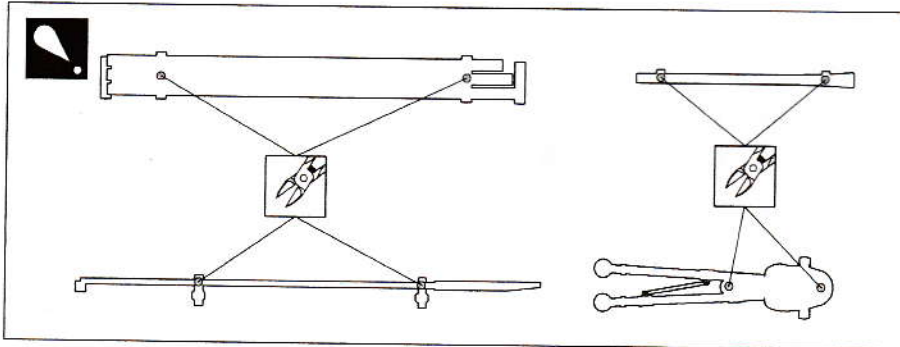
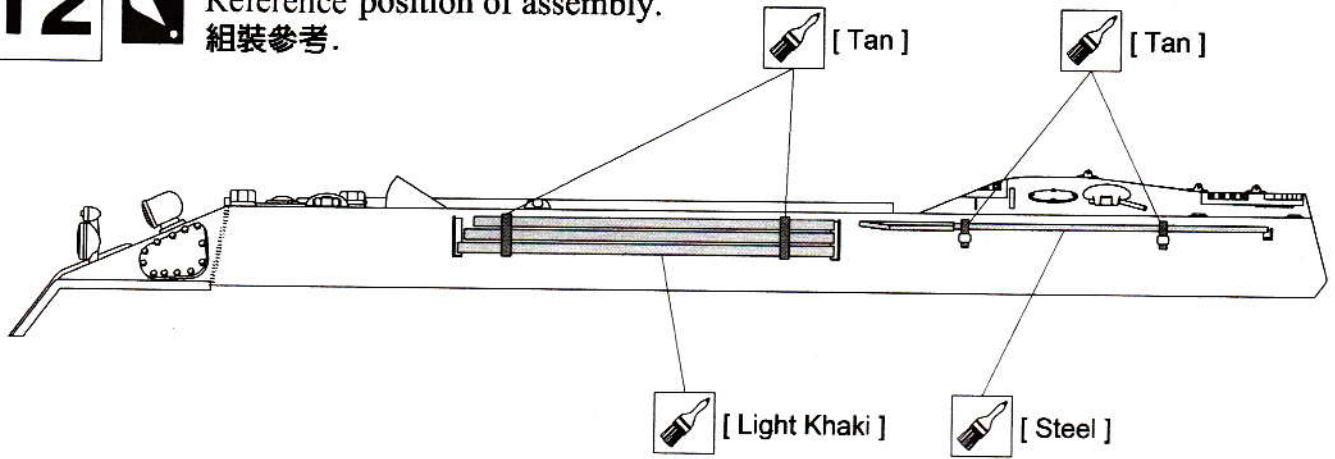

13

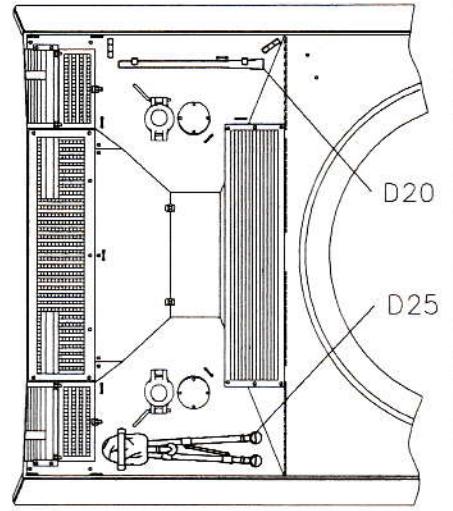
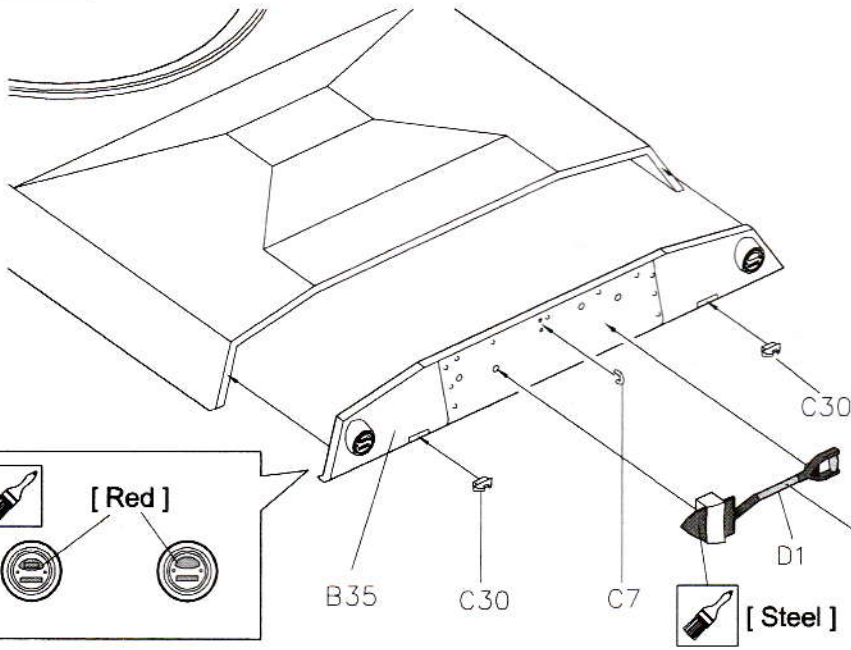

 Reference position of assembly.
組裝參考。

 [Red Brown]

14

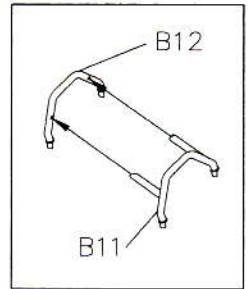
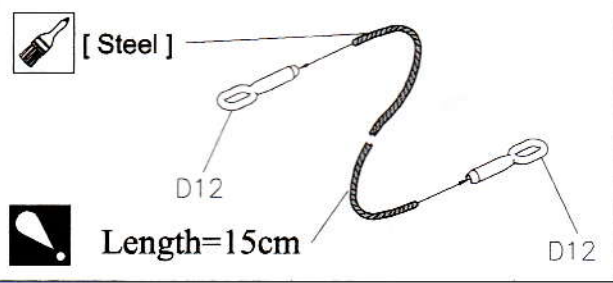

Length=15cm



 [Steel]

D12

D12

B12

B11

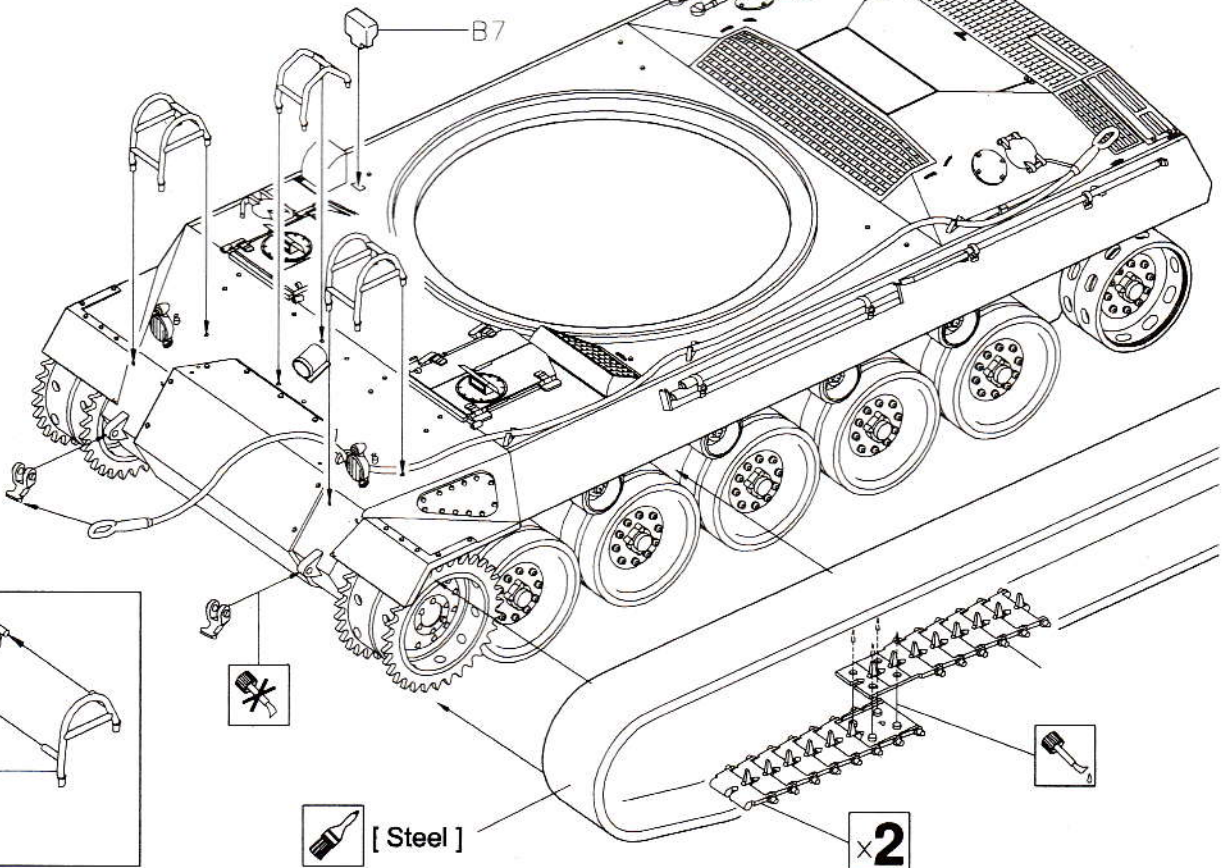

C8

C9

x2

 [Steel]

x2

15

Gun burrel
砲管



Instant gluc.
瞬間膠

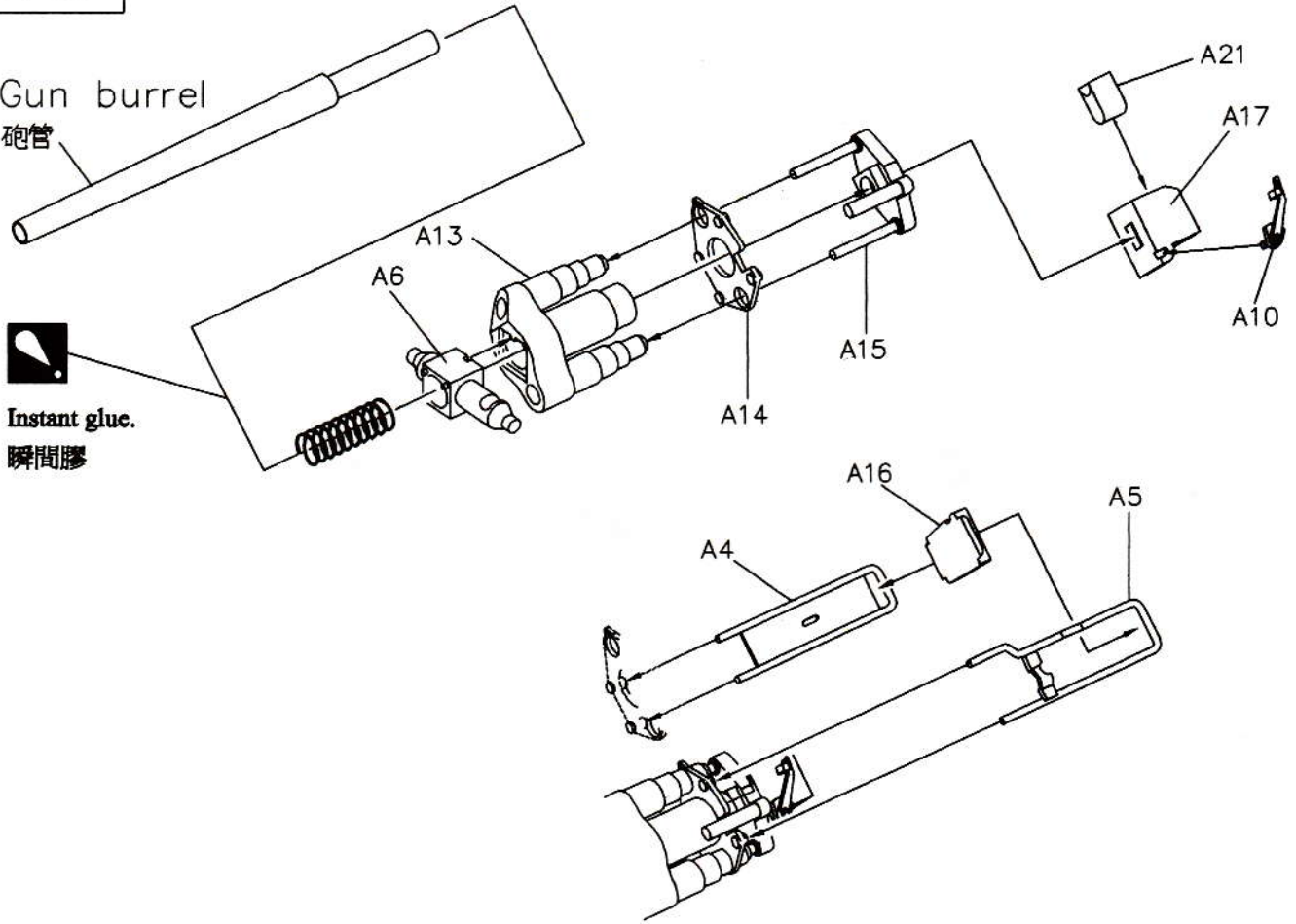

Instant gluc.
瞬間膠

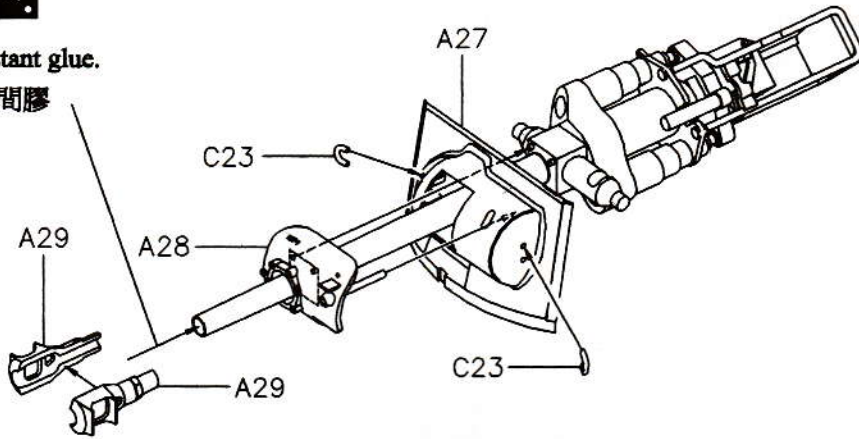

Notice horizontal !!
注意水平

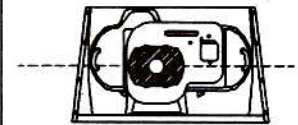

16

Turret lock
砲塔鎖

Hand trersing
mechanism
手搖轉向機構

M20 Azimuth indicator
M20方向指示器

Hydraulic pump
油壓唧筒控制器

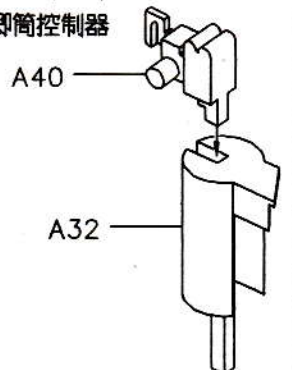
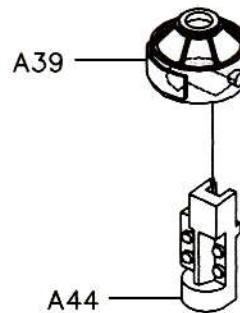
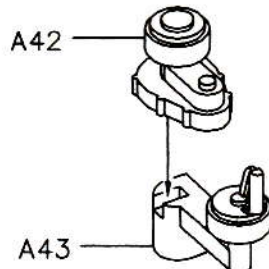
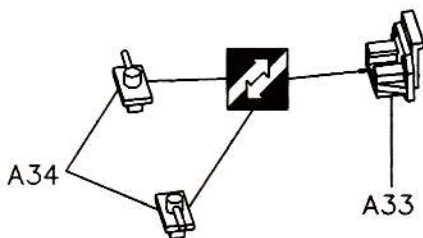

17



Reference of assembly.
組裝參考.

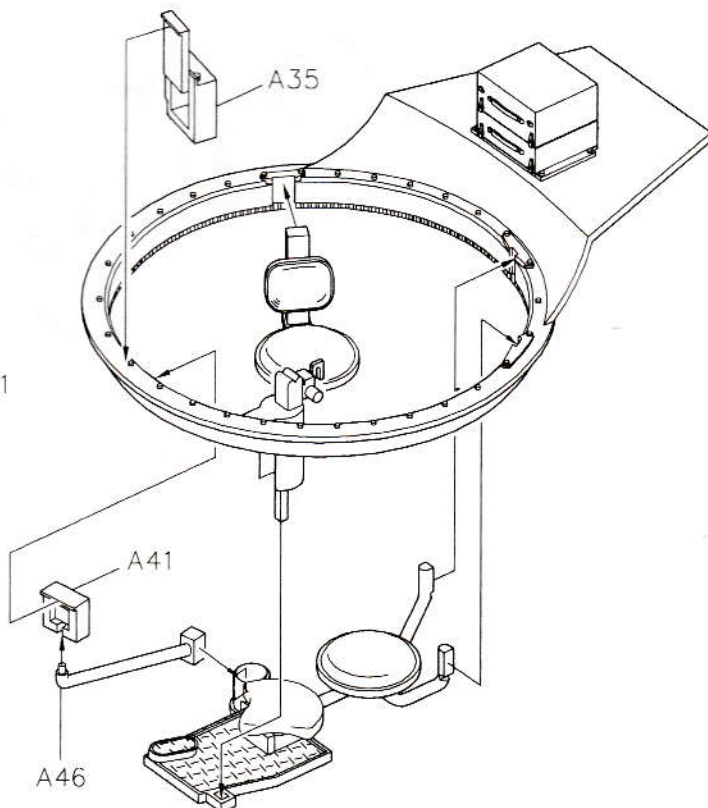
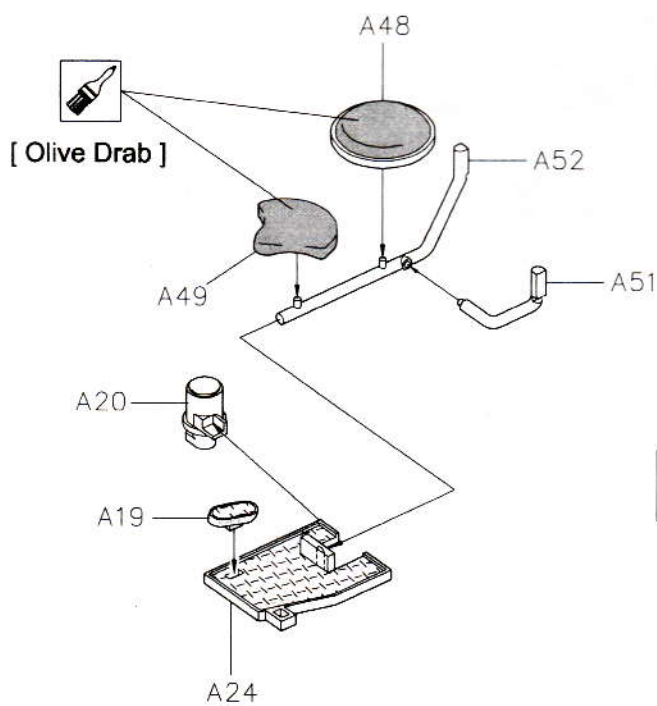
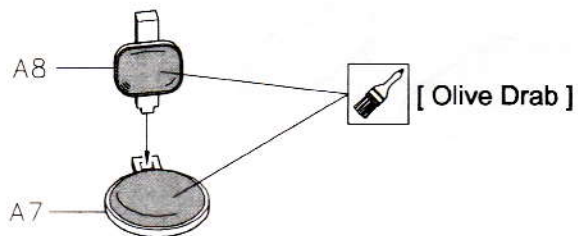
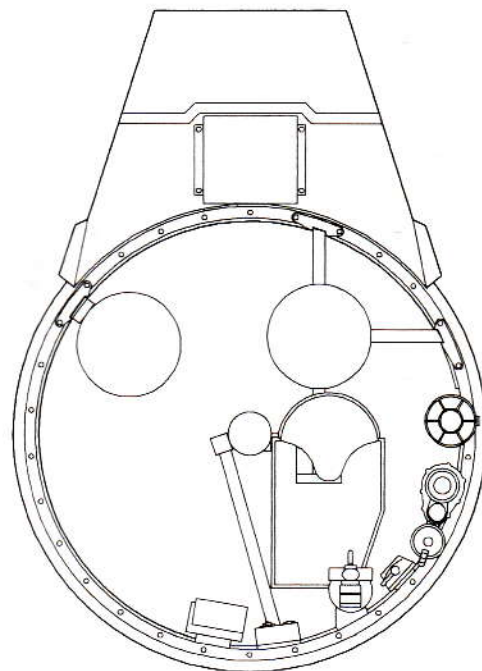
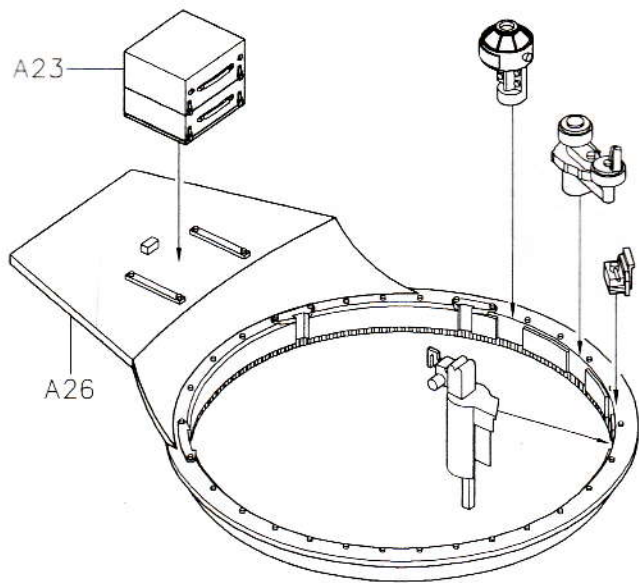

18

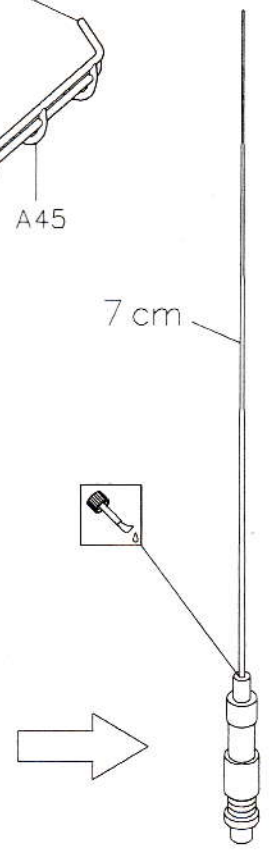
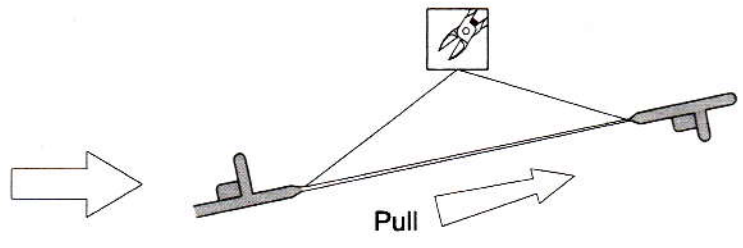
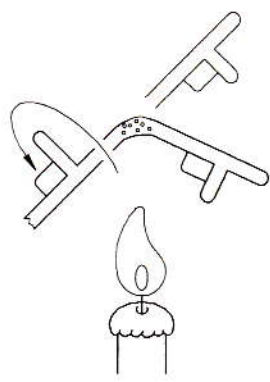
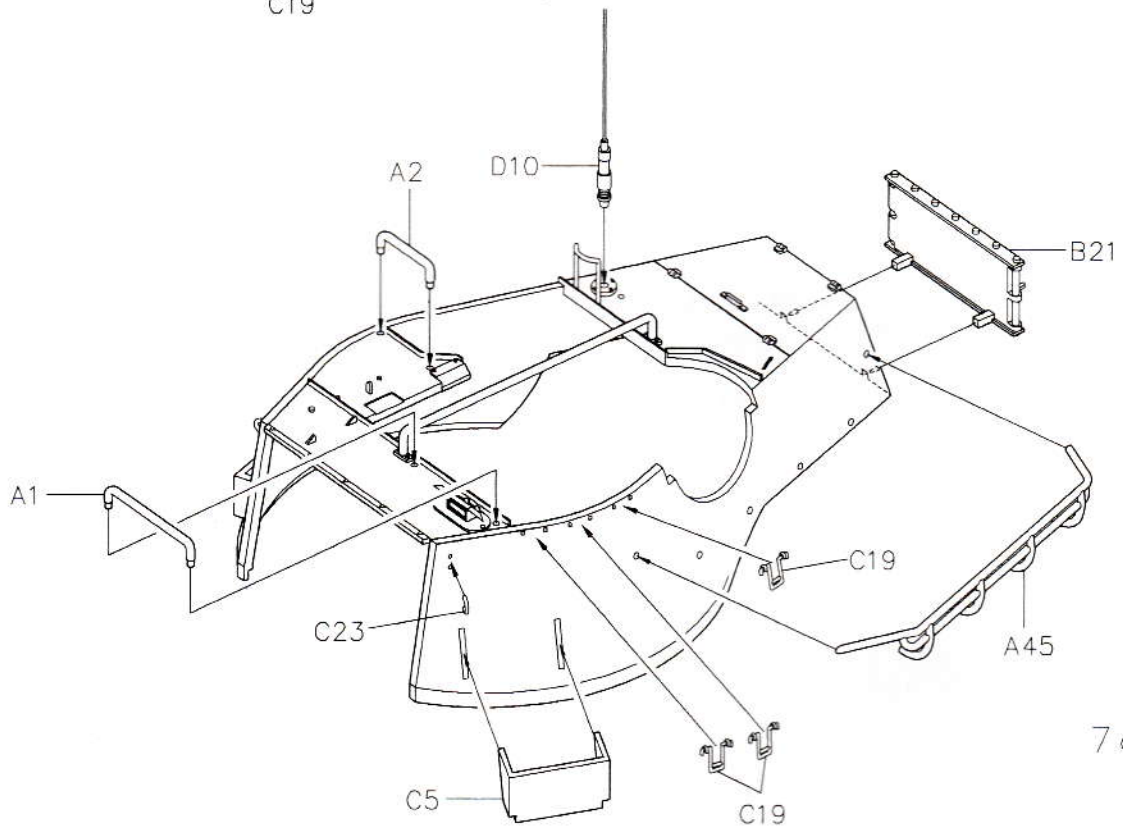
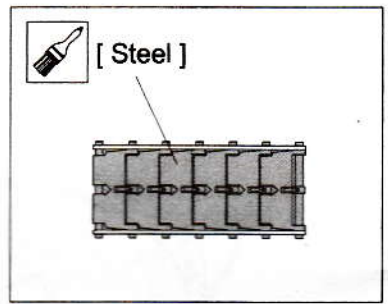
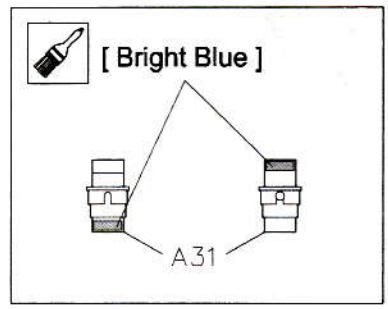
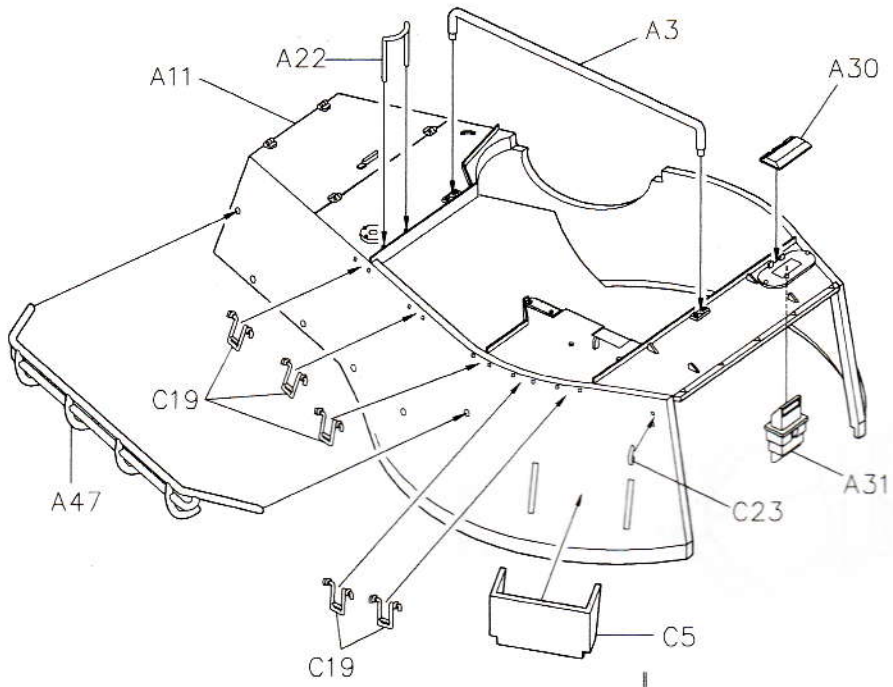

19

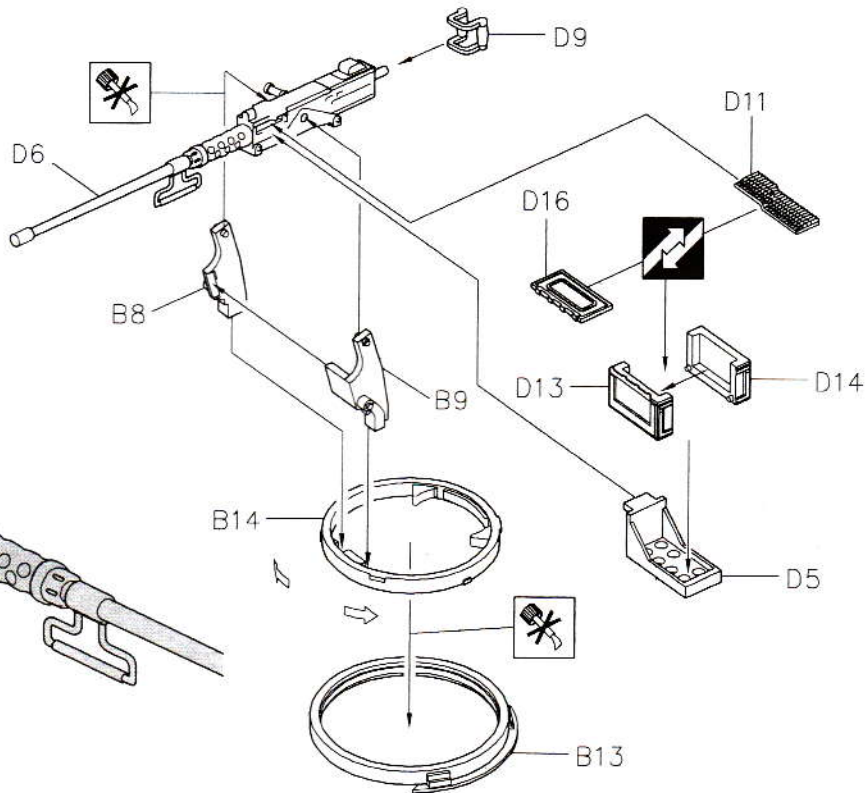
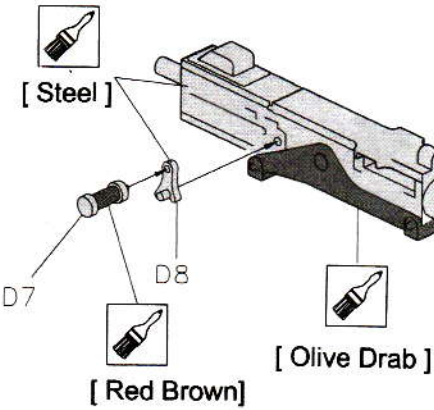
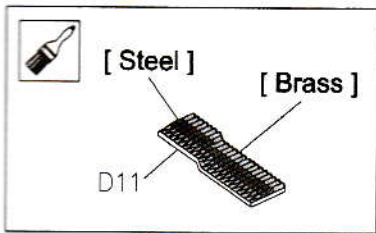

20

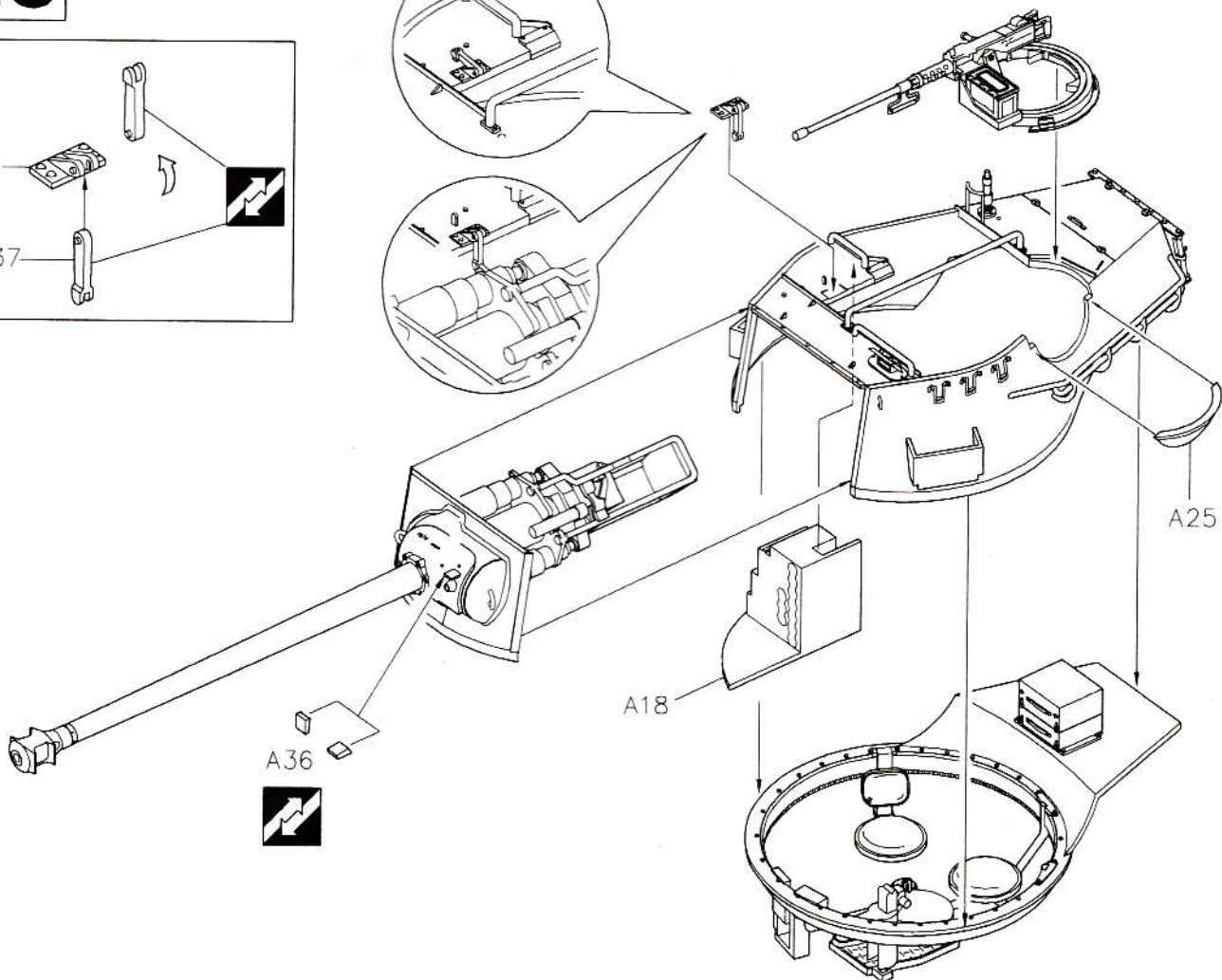
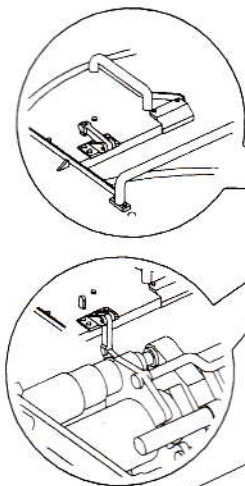
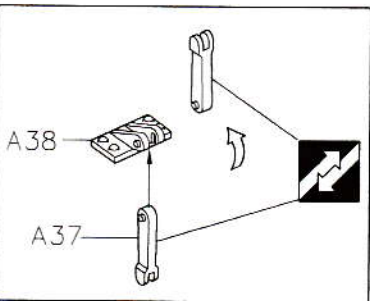

21

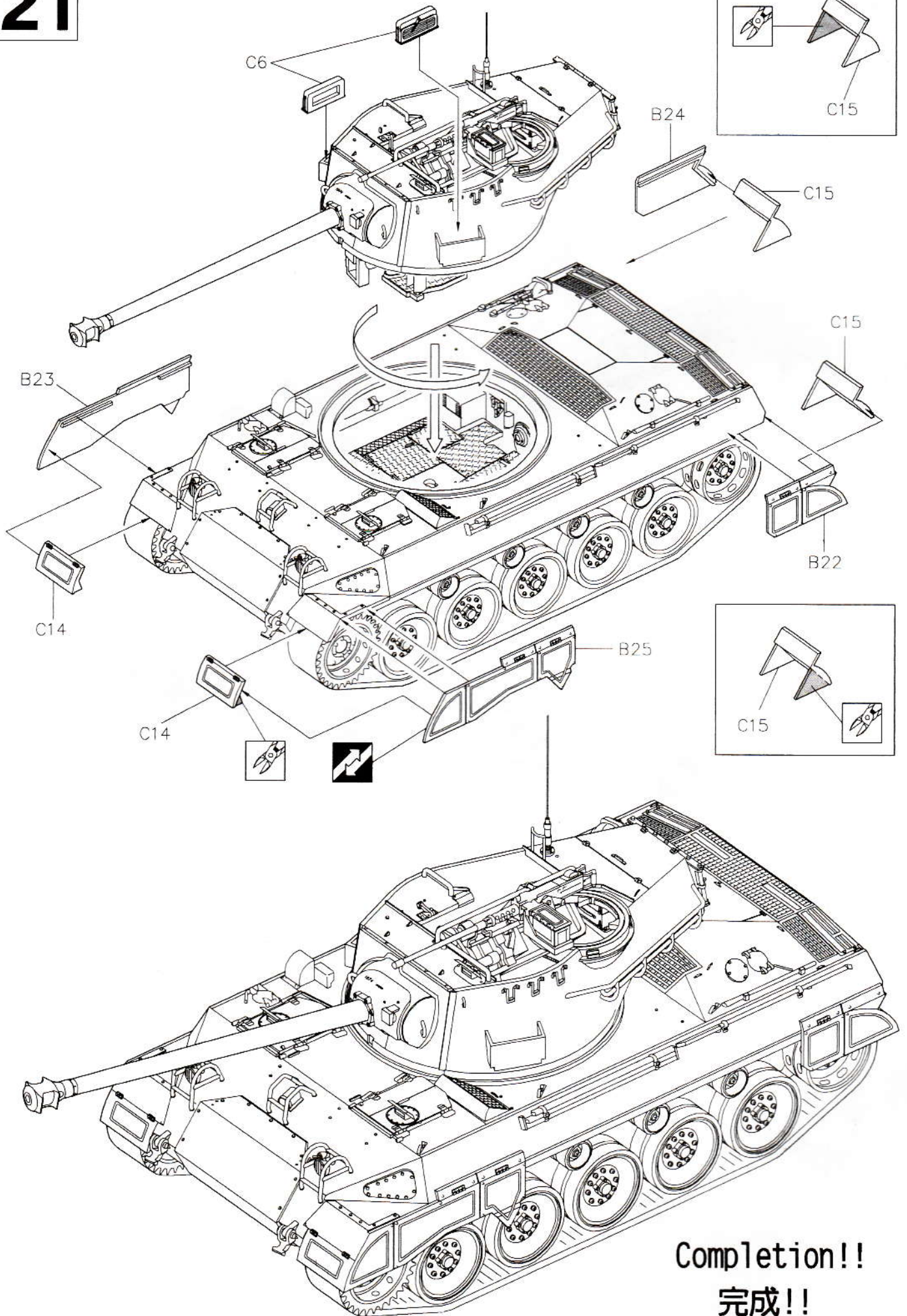

1 Italy 1944

義大利戰線



Body color: [Olive Drab]

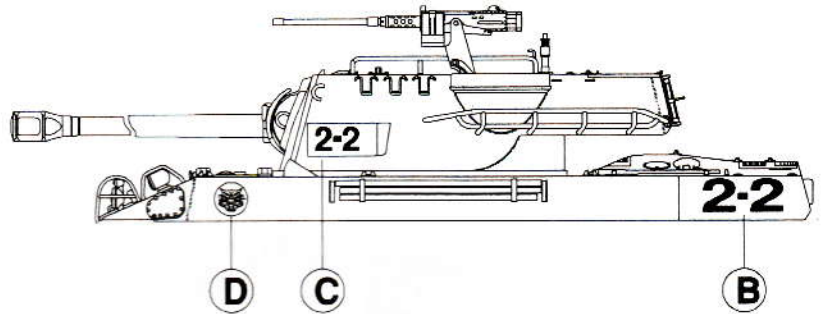
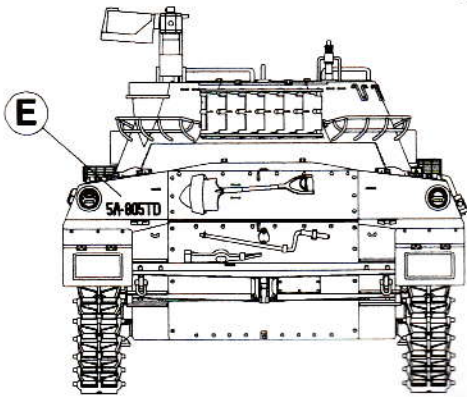
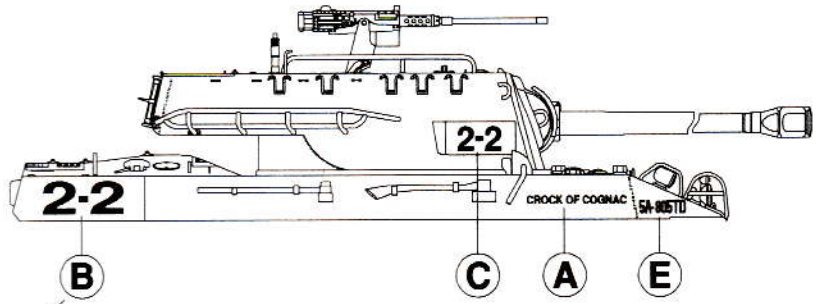
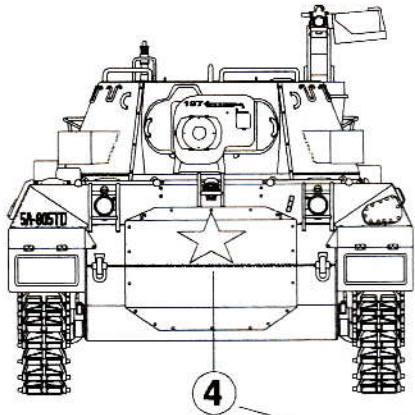

2 France 1944

法國戰線



Body color: [Olive Drab]

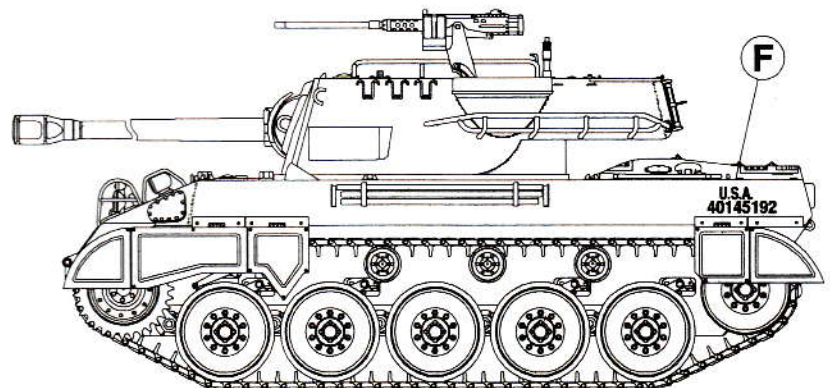
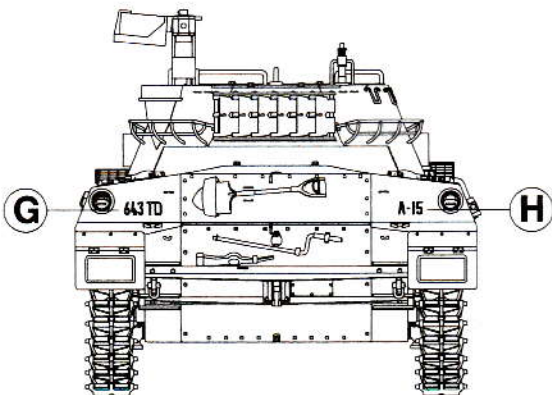
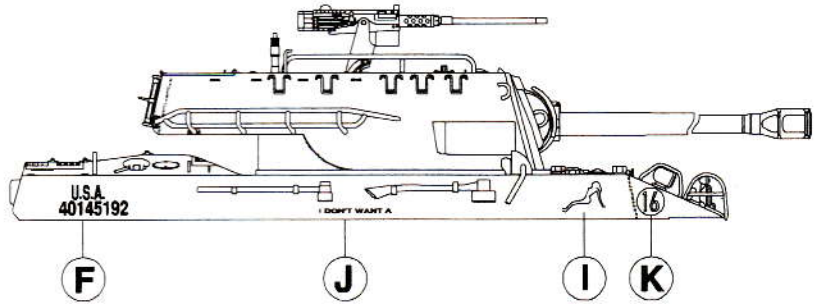
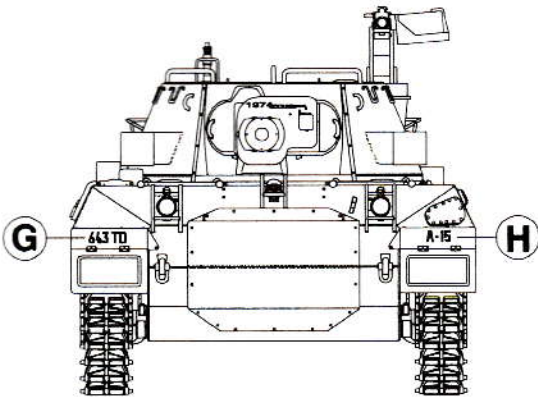

3 Arnheim 1944

突出部戦線



Body color: [Olive Drab]

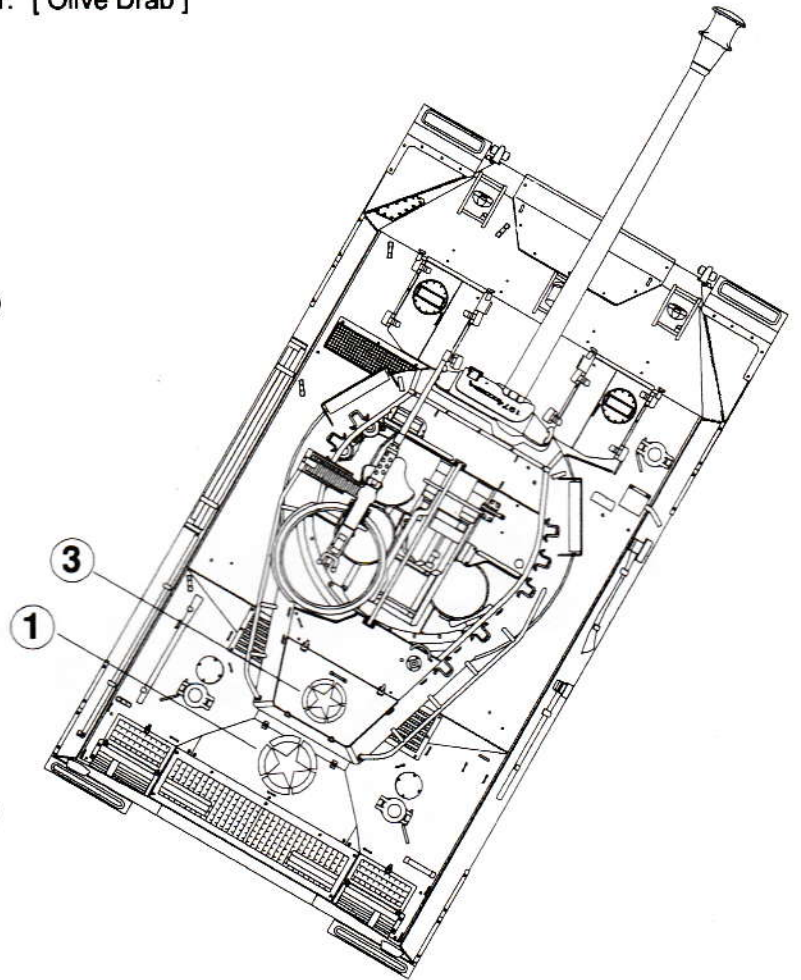
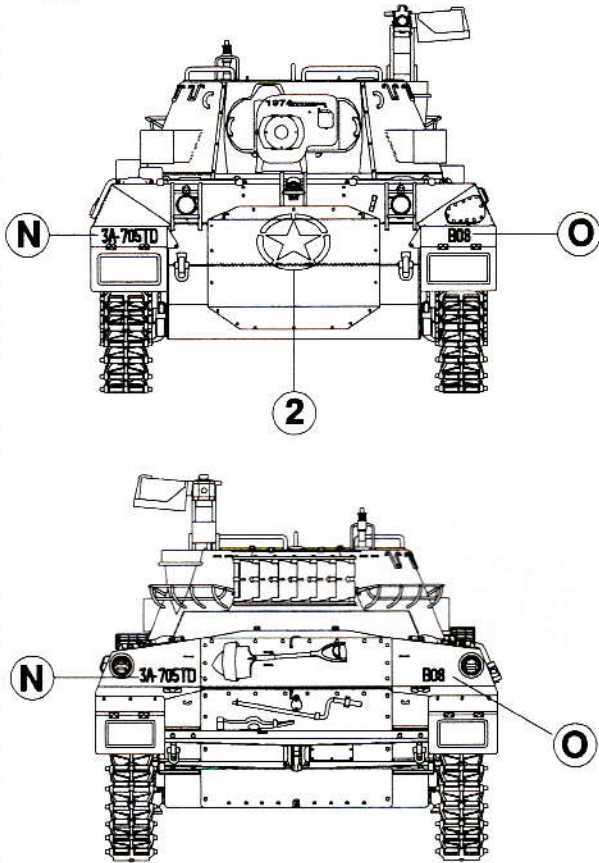

4 Pacific 1944

太平洋戦線



Body color: [Olive Drab]

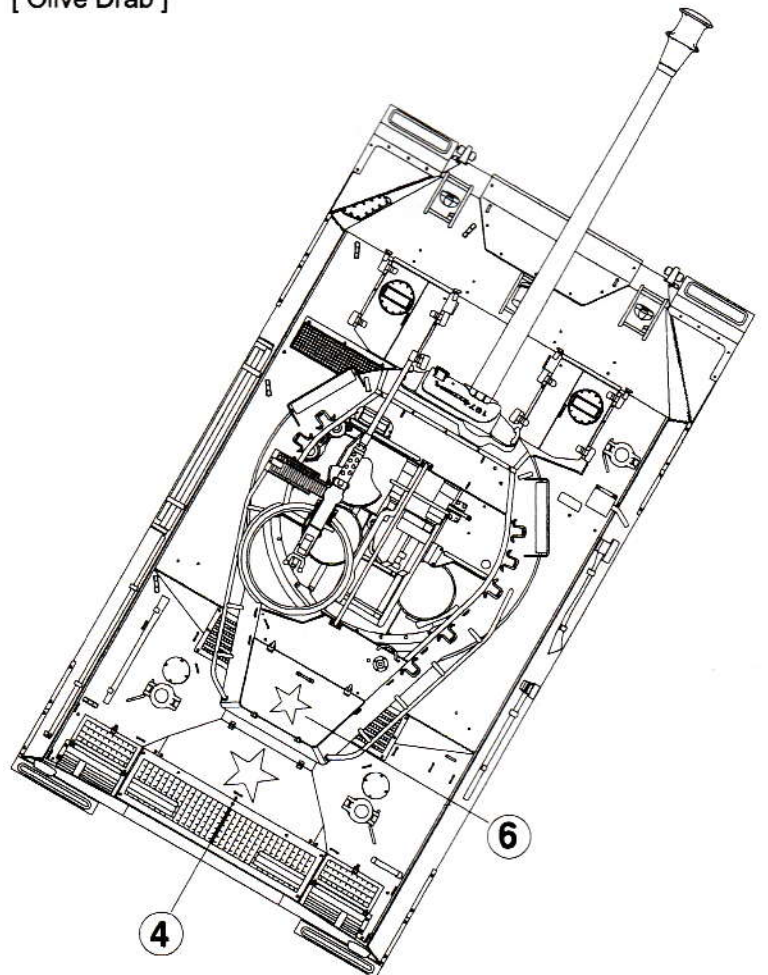
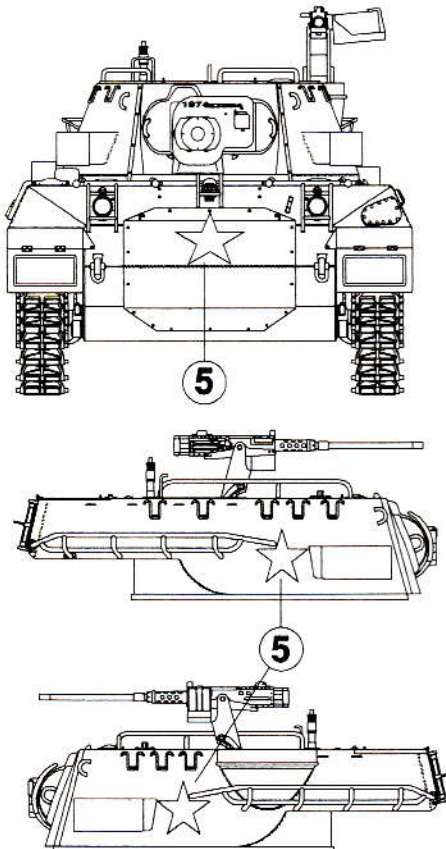

5 R.O.C. Marine corps.
中華民國海軍陸戰隊



Body color: [Olive Drab]

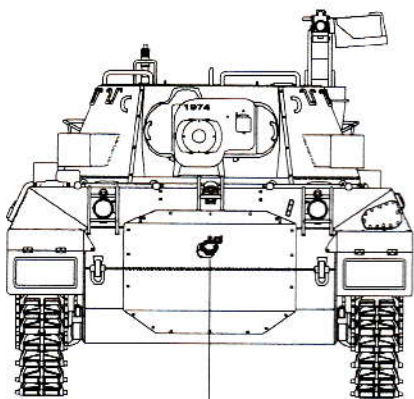

W

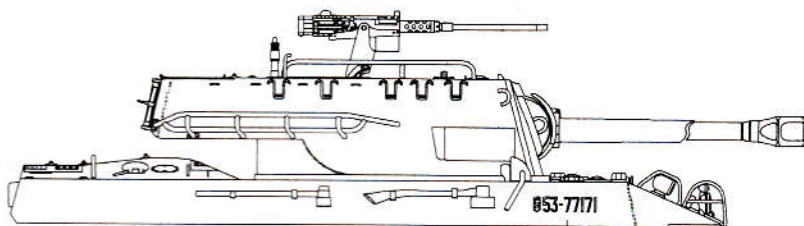

V

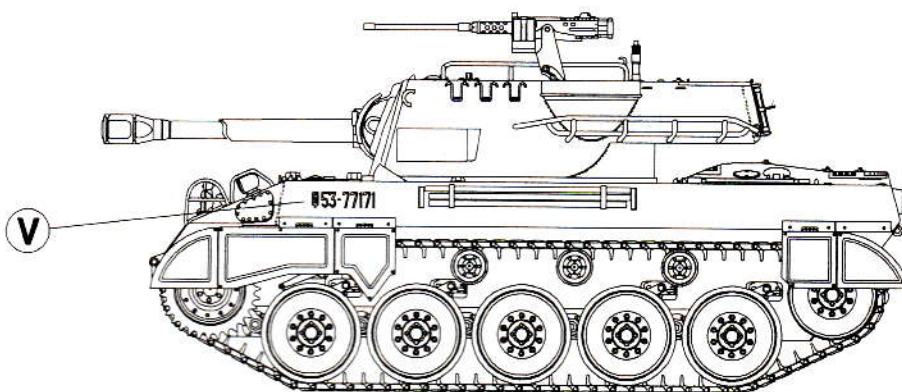

V

6 Postwar reconstruct France 1944.
法國戰線-戰後復原車.



Body color: [Olive Drab]

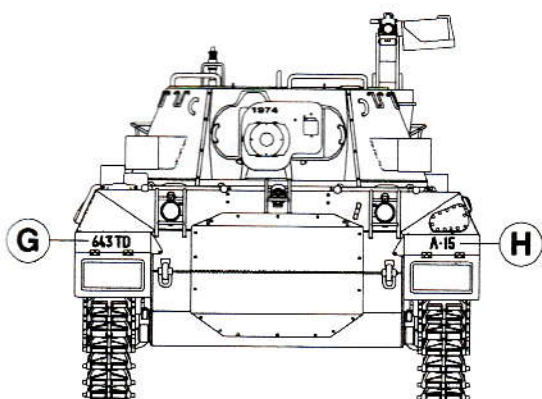

G

H

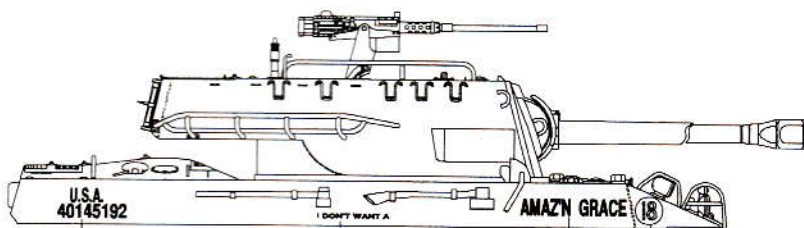

F

J

M

L

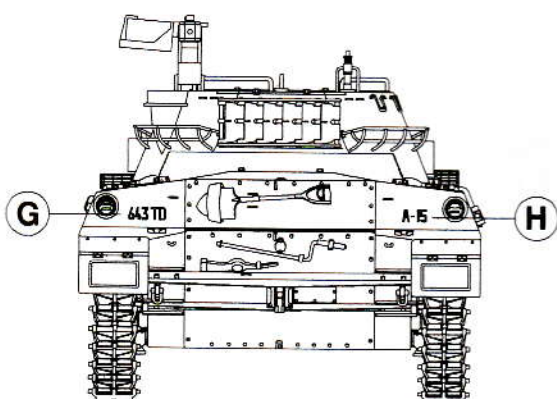

G

H

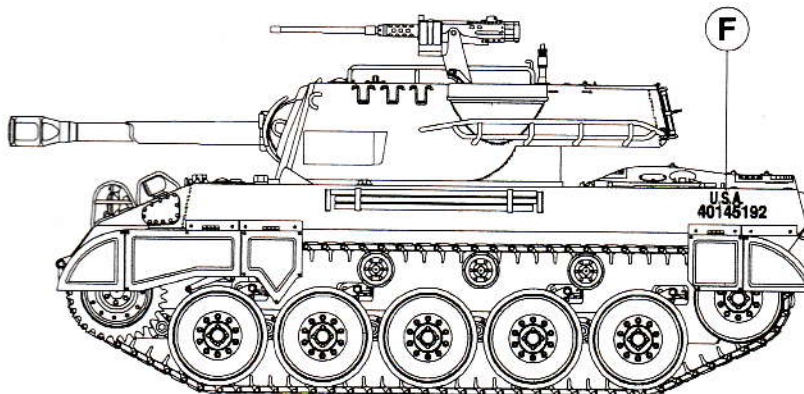

F

7 Italy military academy.
義大利陸軍學校



Body color: [Olive Drab]

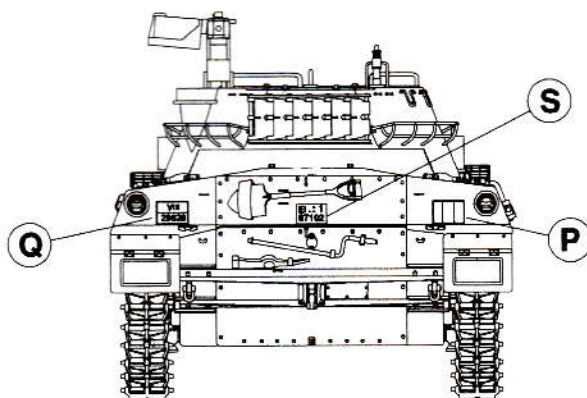
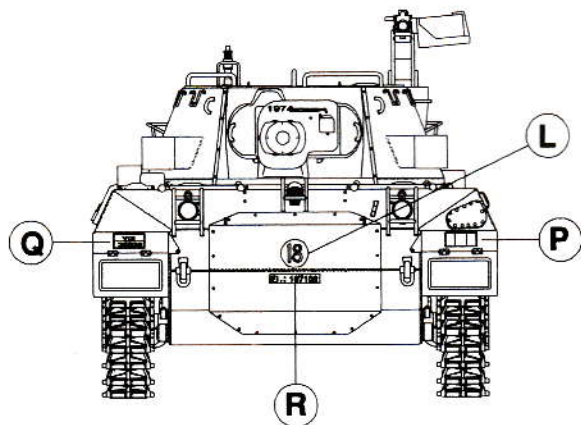
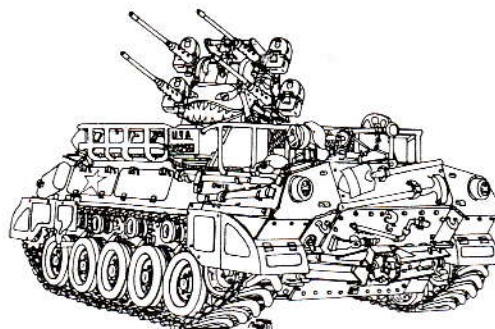
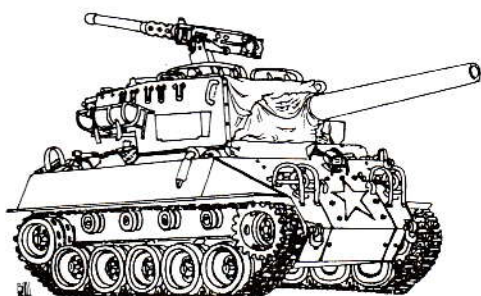

8 R.O.C. Army the 249 MAC. division.
中華民國陸軍249師



Body color: [Olive Drab]
[Flat Black]
[Red Brown]

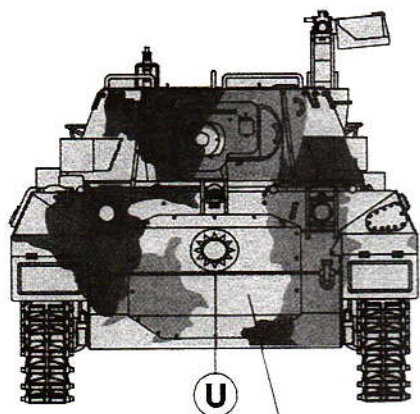

[Olive Drab]

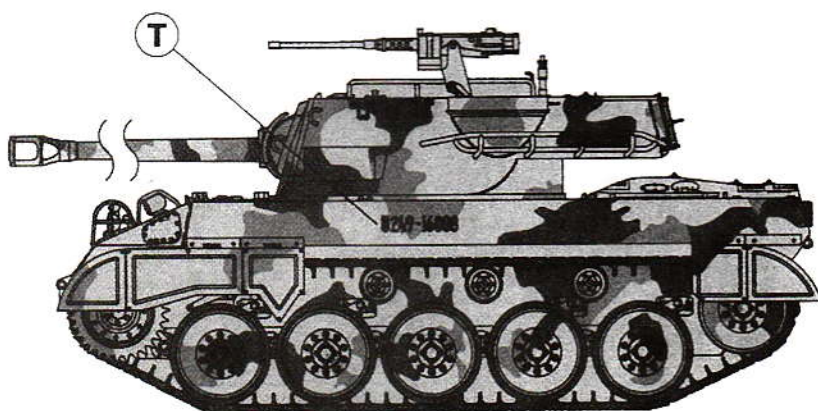

[Flat Black]

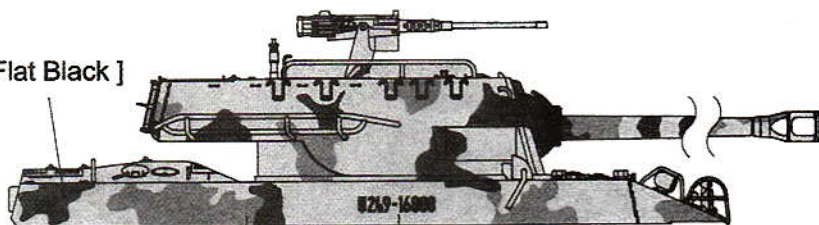

[Red Brown]

Parts list:

零件表

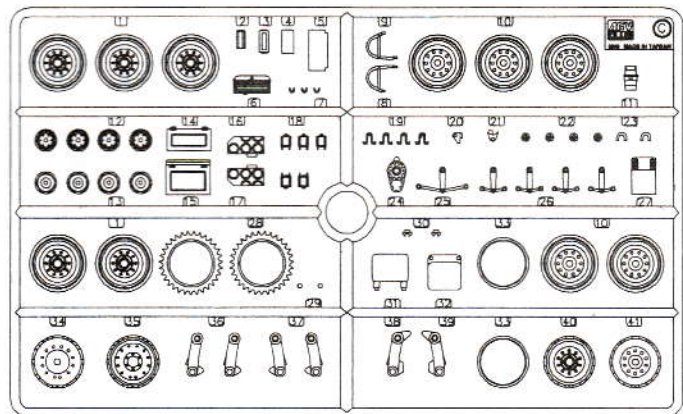
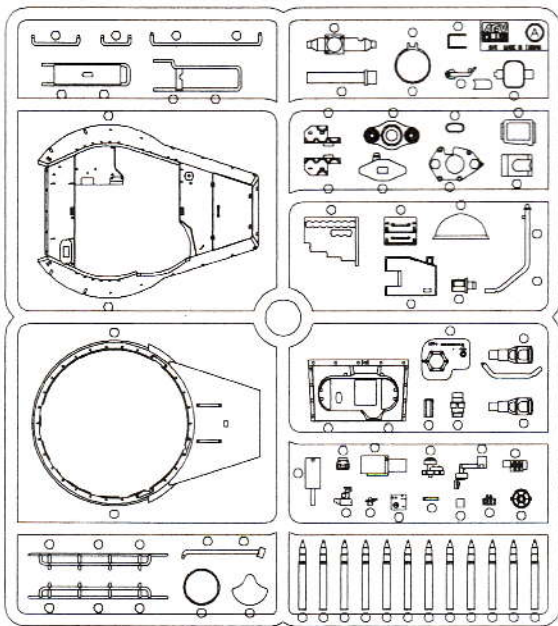

x2

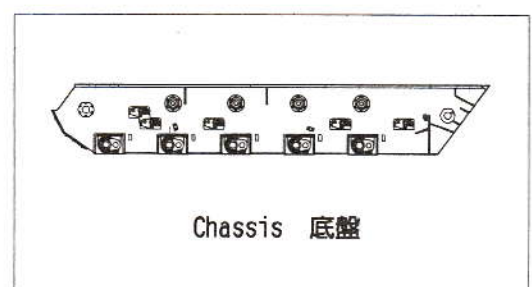
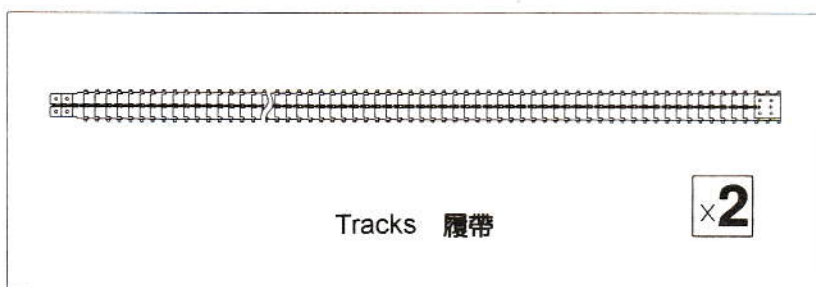
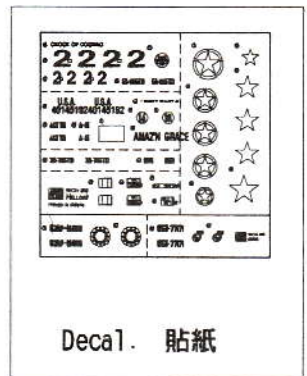
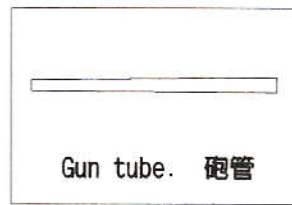
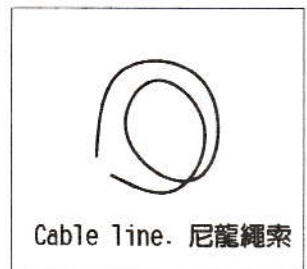
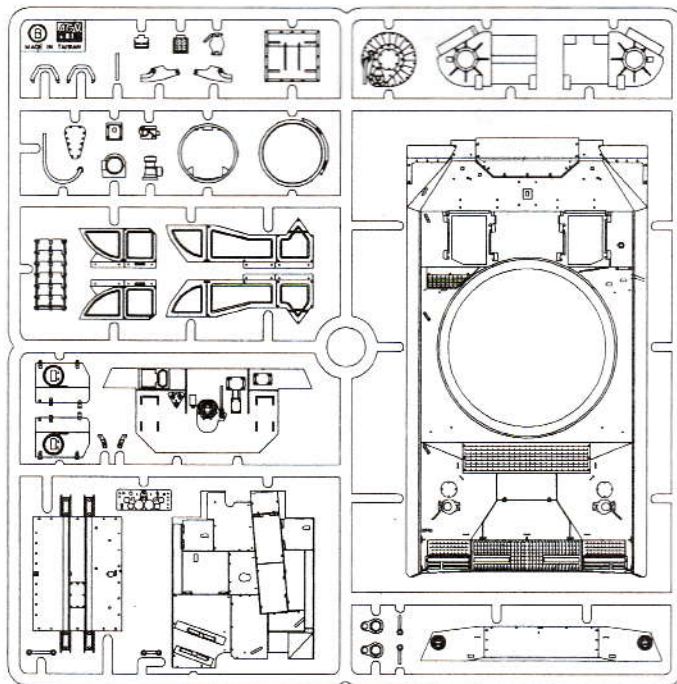
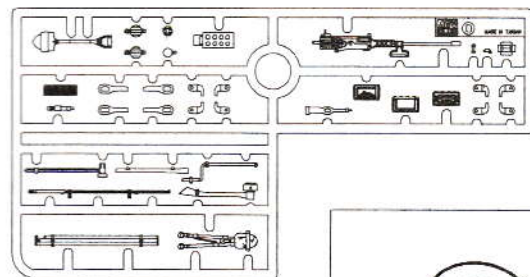



Drill hole 0.5mm.

使用0.5mm鑽頭加工。

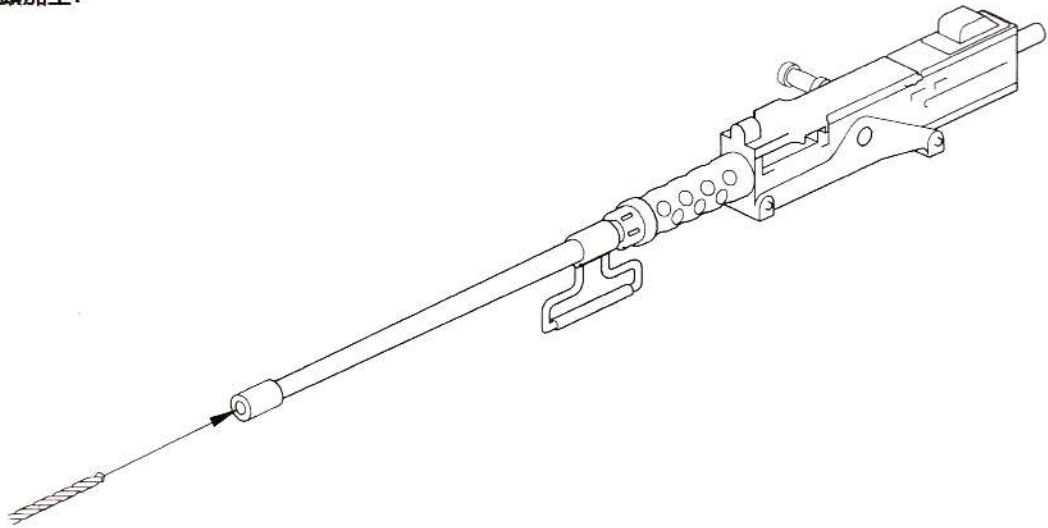

Instructions:

If for some reason, you are not fully satisfied or have questions concerning our product; Please use the form provide, and send it to our nearest representative or mail it directly to our office.

We will deal with that A.S.A.P.



限國內使用 (For Taiwanese use only!)

使用方法:

請將申請表與該部品相同金額之郵政匯票一並寄至總代理：戰鷹企業有限公司 客服部收，本公司將盡速為您處理！



AF35015 Parts Replacement Form

- | | |
|----------------------------------|-----------------------------------|
| <input type="checkbox"/> A parts | <input type="checkbox"/> Spring |
| <input type="checkbox"/> B parts | <input type="checkbox"/> Gun tube |
| <input type="checkbox"/> C parts | <input type="checkbox"/> Chassis |
| <input type="checkbox"/> D parts | <input type="checkbox"/> Decal |
| <input type="checkbox"/> Tracks | |

Reason for replacement: Missing Broken

Signature: _____



AF35015 零件補充申請表

- | | | |
|---------------------------------|-------|------------|
| <input type="checkbox"/> A 部品零件 | ----- | NT\$ 220 |
| <input type="checkbox"/> B 部品零件 | ----- | NT\$ 200 |
| <input type="checkbox"/> C 部品零件 | ----- | NT\$ 150 |
| <input type="checkbox"/> D 部品零件 | ----- | NT\$ 120 |
| <input type="checkbox"/> 彈簧 | ----- | NT\$ 20 |
| <input type="checkbox"/> 履帶 | ----- | NT\$ 70 |
| <input type="checkbox"/> 砲管 | ----- | NT\$ 50 |
| <input type="checkbox"/> 底盤 | ----- | NT\$ 120 |
| <input type="checkbox"/> 貼紙 | ----- | NT\$ 50 |
| | + 郵資 | NT\$40 |
| (請填) 總計 | | NT\$ _____ |

零件補充原因: (請於 打✓)

原包裝即 遺失或 毀損

製作途中 遺失或 毀損

補充多餘零件.

其它原因 _____