

## Assembly guide

## 1/48 Scale



Do the same for the opposite side



Options



Use Wingman parts instead

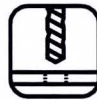

Drill a hole



Apply decal



Photo etch parts. Glue with Super glue.



Multiple time



Painting Instructions



Important Notes

### CAUTION

- \*Read carefully and fully understand the instructions before commencing assembly.
  - \*Keep out of reach of children. Children must not be allowed to put any parts in their mouths, or pull plastic bag over their heads.
  - \*When using adhesives and paints, please make sure not to use them in closed room or near the fire.
  - \*When assembling this kit, tools including knives are used. Extra care should be taken to avoid injury.
- WARNING: CONTAIN SMALL PARTS NOT FOR CHILDREN UNDER 14 YEARS OF AGE.**

### Plastic parts

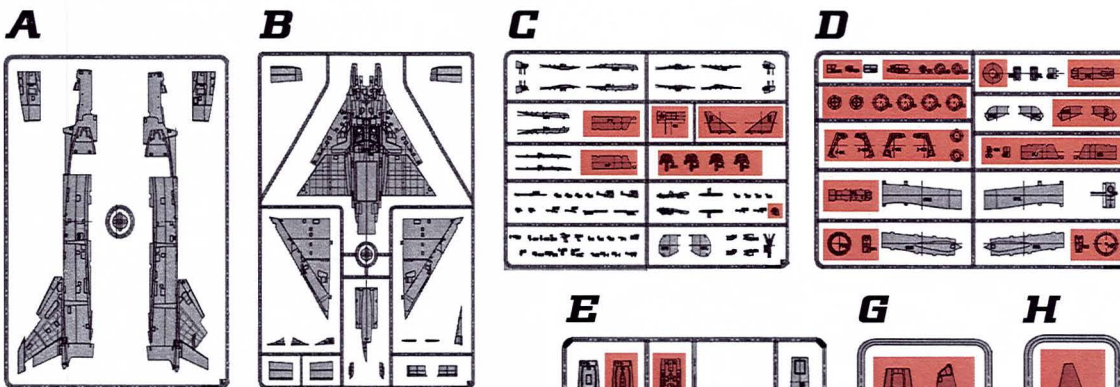

### Etched metal parts

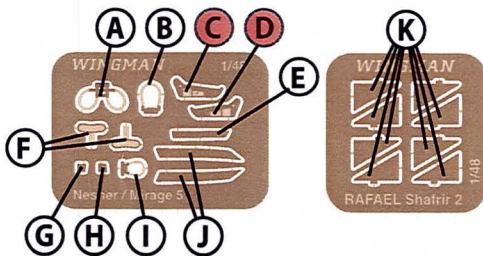

### Resin parts

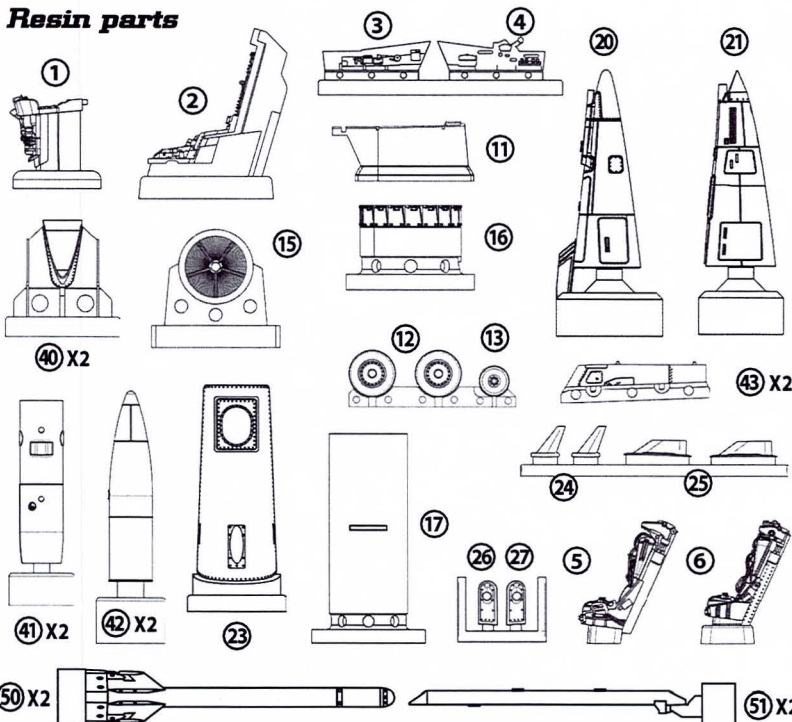

### Paper masking

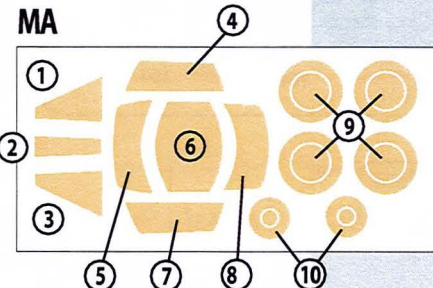

### Brass parts

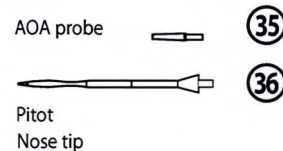

Our painting instructions refer to the CSI Creos Mr. Hobby (H x) and Humbrol (HU x) ranges of paints. Paints required for this model are:

### CSI Creos Mr. Hobby

- H 1 White
- H 2 Black
- H 3 Red
- H 4 Yellow
- H 8 Silver
- H 18 Steel
- H 21 Off-White
- H 28 Metal Black
- H 77 Tire Black
- H 318 Radome (Beige)

### Humbrol

- HU 26 Khaki
- HU 56 Aluminium
- HU 66 Dark Olive Drab
- HU 81 Brownish Yellow
- HU 86 Light Olive
- HU 99 Lemon
- HU 155 Olive Drab
- HU 159 Khaki Drab

These paints are available online on our website: [www.shopofphantoms.com](http://www.shopofphantoms.com)







Mk.4

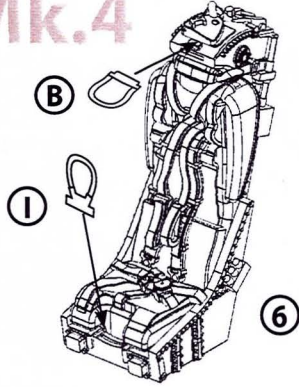

Mk.6

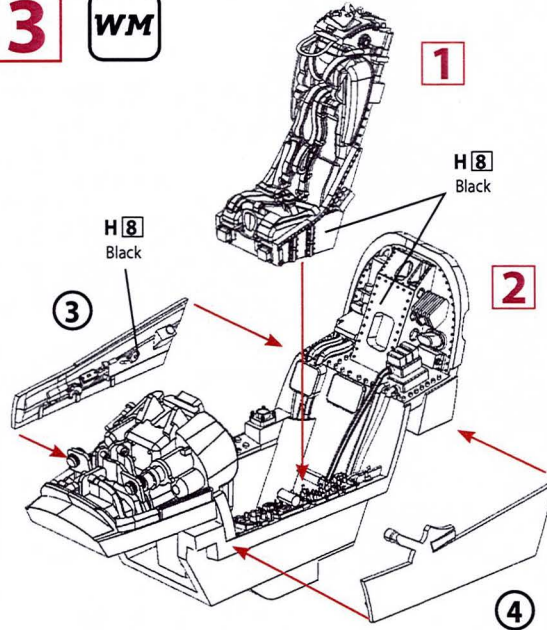
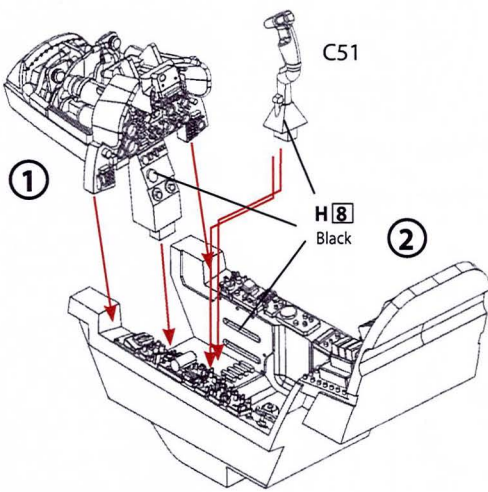
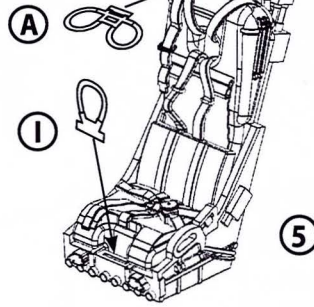

**Instrument panel colouring and decal application**

1. Paint the complete instrument panel in matt black.

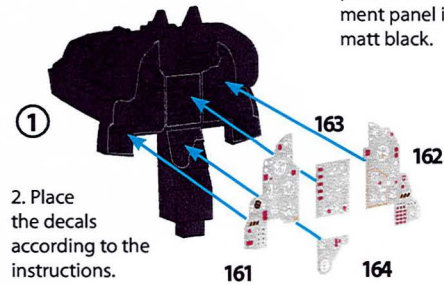

2. Place the decals according to the instructions.

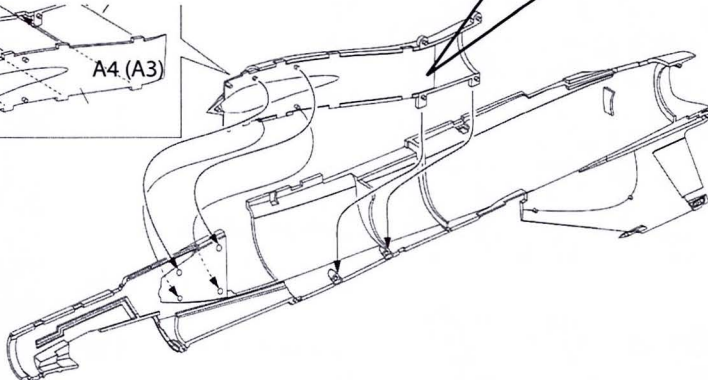
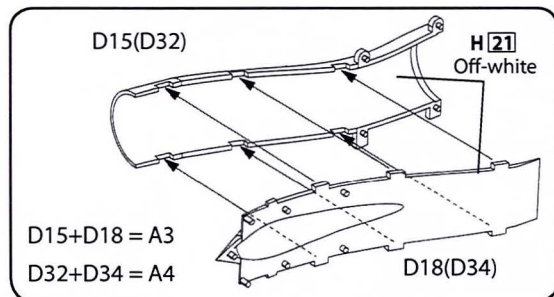

Early Neshers were delivered with Martin Baker Mk.4 seats. After the Yom Kippur War during the mid 1970's, these seats were replaced by the MB Mk.6. The latter was retained even by the FAA when the Neshers were converted to Dagger and later to Finger standards.  
NOTE: Some Mk.4 seats were retrofitted with dual handles on top, so check your reference carefully!



Paint cockpit tub, sidewalls and instrument panels **H8** Black, including the bulkhead behind the seat's headrest and avionic housings.

Paint the metal frame of the Mk.4/6 ejection seat **H8** Black with parachute housing under the headrest in HU 163. Remaining cushions were HU 159 Khaki Drab. Shoulder and side belts in HU 81 Brownish Yellow. Middle main belt in HU 66 Olive Drab. Other colours in use are Red, Yellow, White, Black and Aluminium.

**(For more details see our photos in the painting guide)**



Numbers in brackets refer to the other side.



Paint intake trunks Mr. Hobby **H21** Off-white.



Attach parts A3 and A4 after installing the inner intake parts (4).



**6** WM

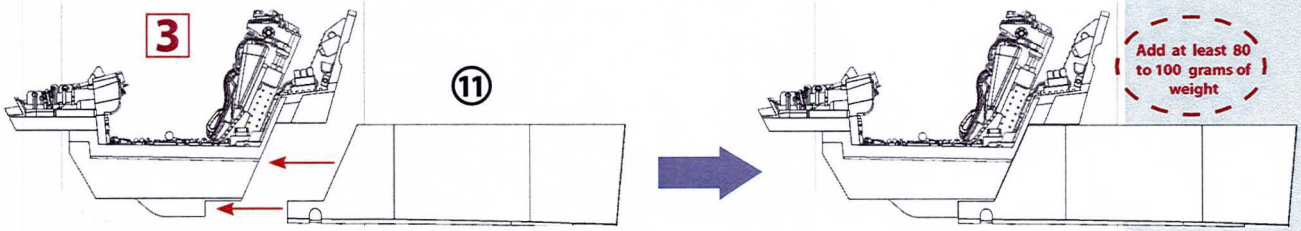

**7** WM

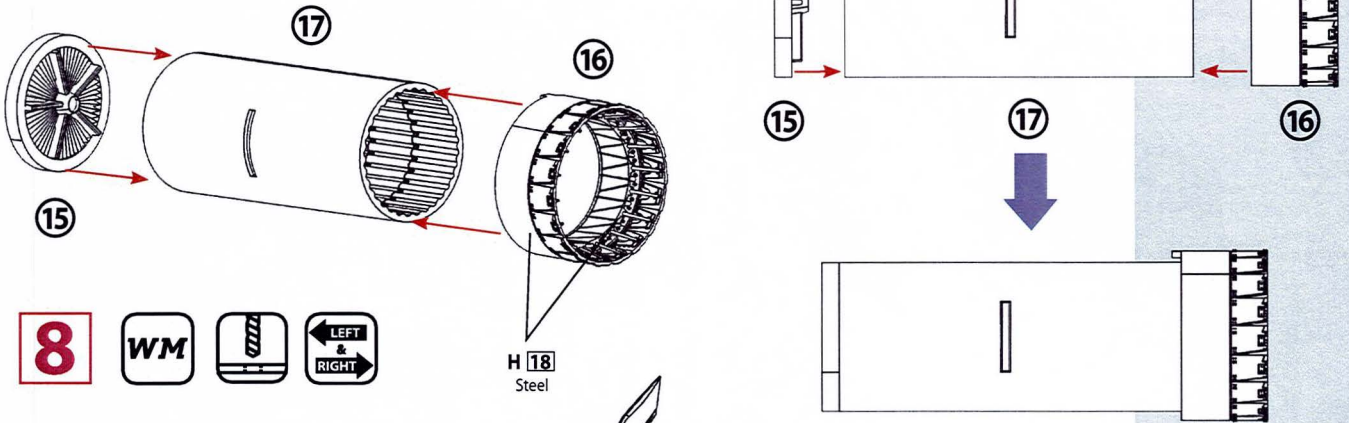

**8** WM

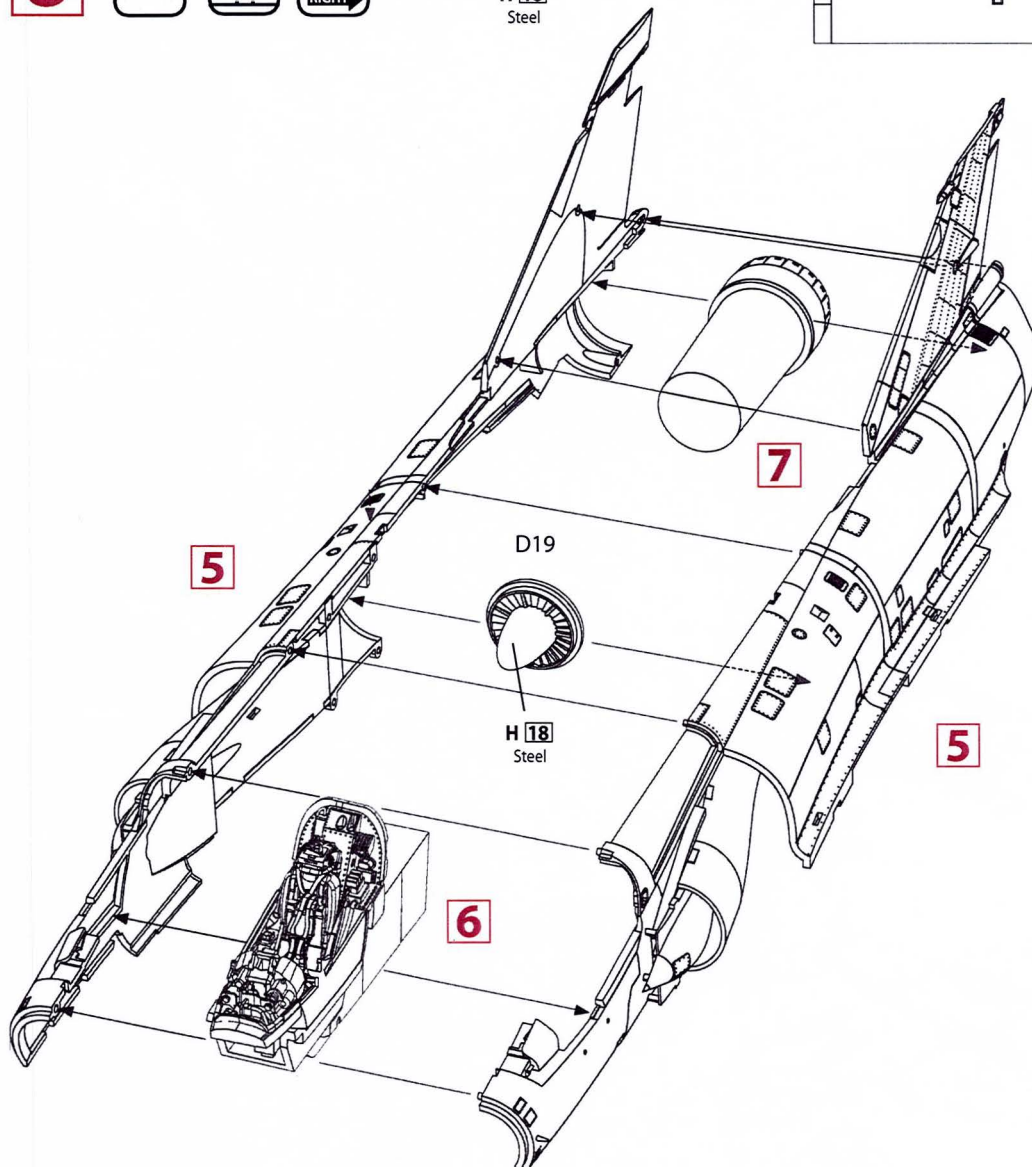

Paint exhaust and nozzle in various shades of Mr. Hobby H 18 Steel.



As the model might be a bit tail heavy with resin wing tanks and exhaust - add at least 80 to 100 grams of weight behind the cockpit.



10

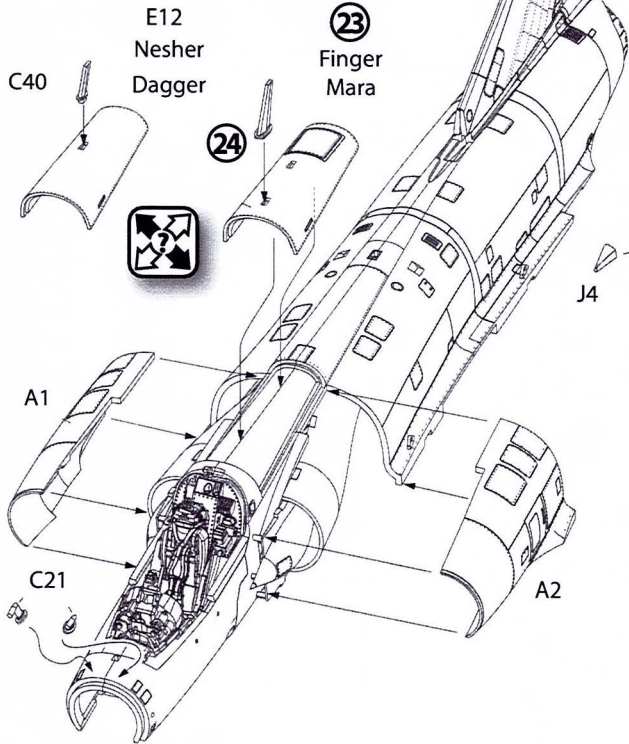

11

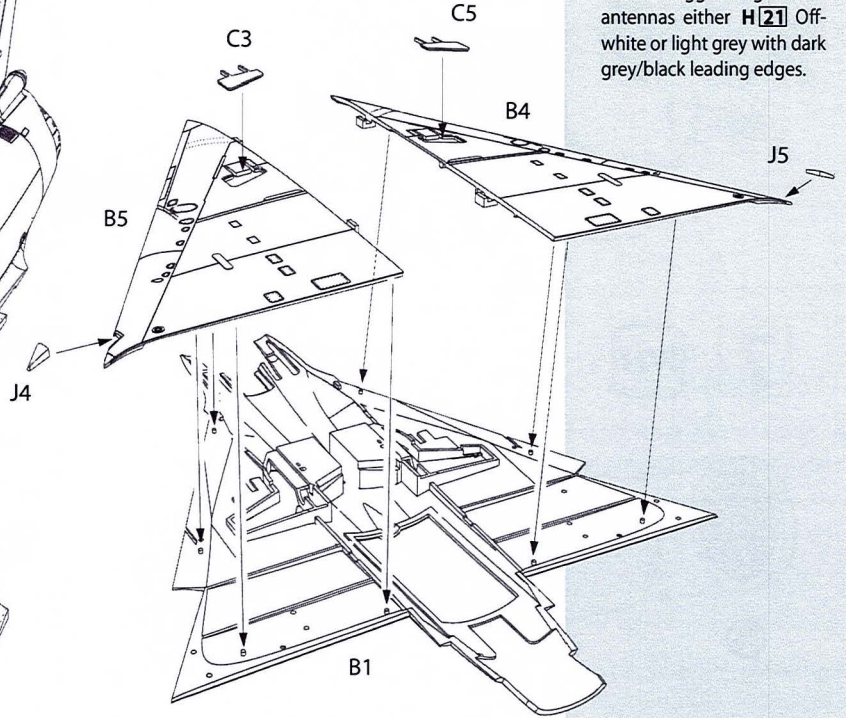

Paint Dagger/Finger/Mara antennas either **H 21** Off-white or light grey with dark grey/black leading edges.

12

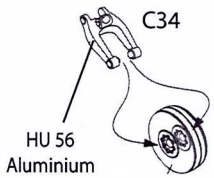

13

13

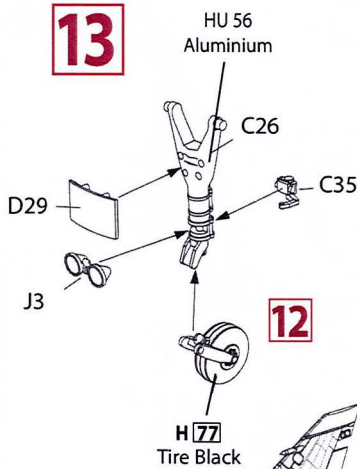

14

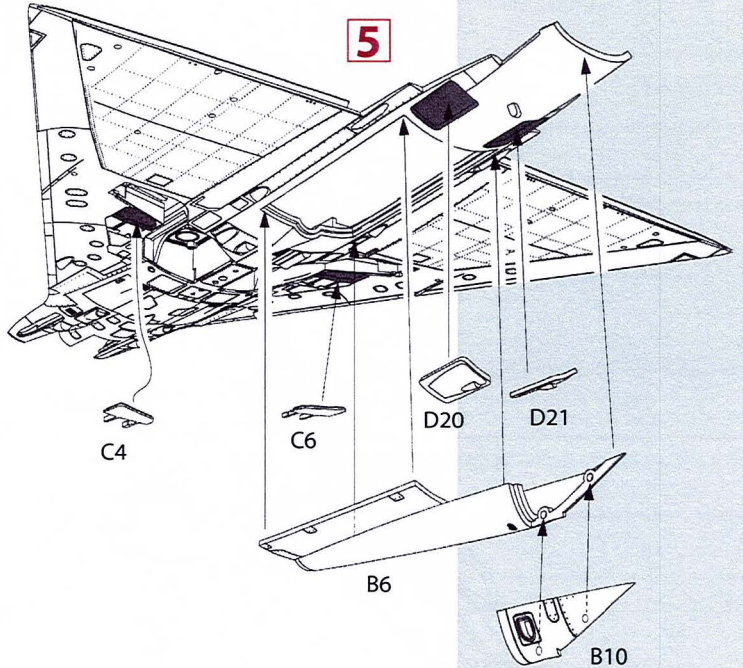

15

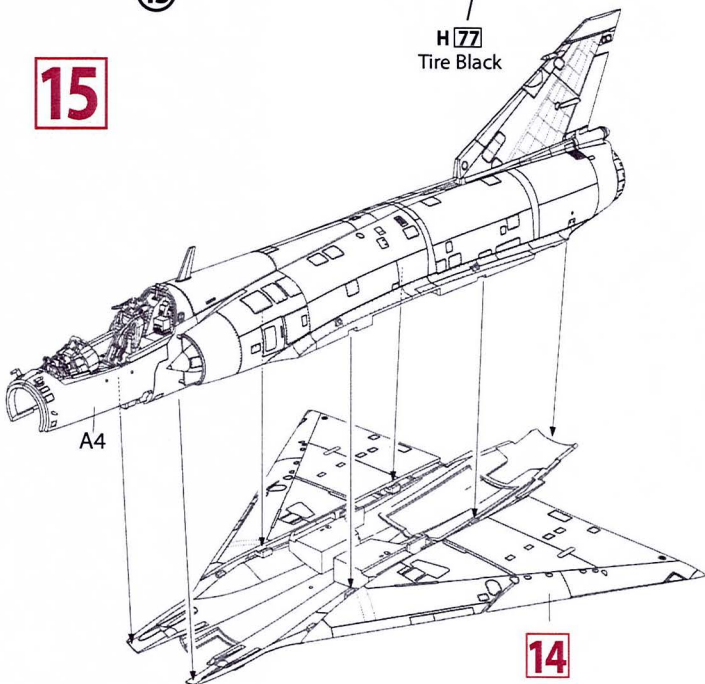

16

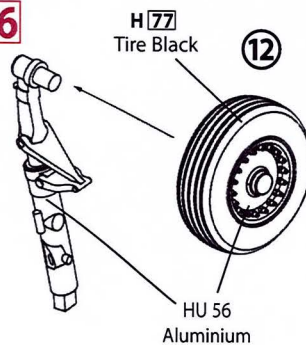

Paint all wheel hubs, front and main and landing gear HU 56 Aluminium. Oleolegs should be painted in **H 81** Silver and the tires **H 77** Tire Black. Our kit includes pre-cut masking paper, which will help you paint the front and main wheels.



**16** WM

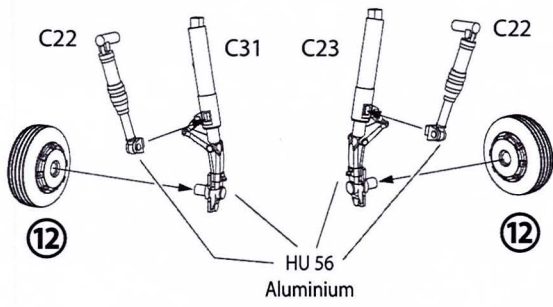

**17**

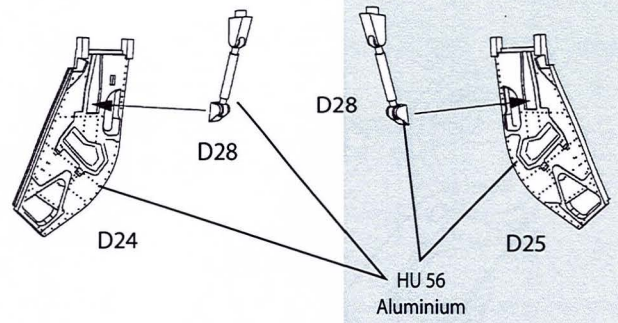

**18**

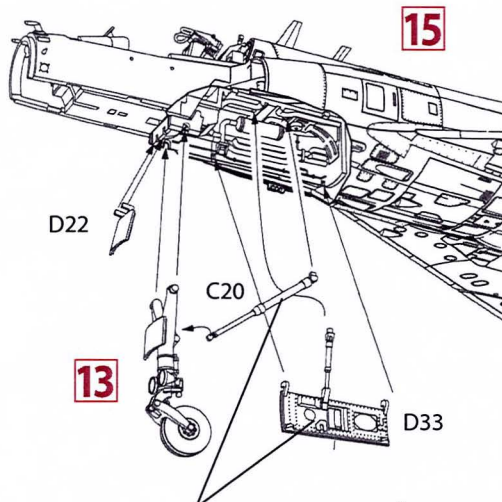

**15**

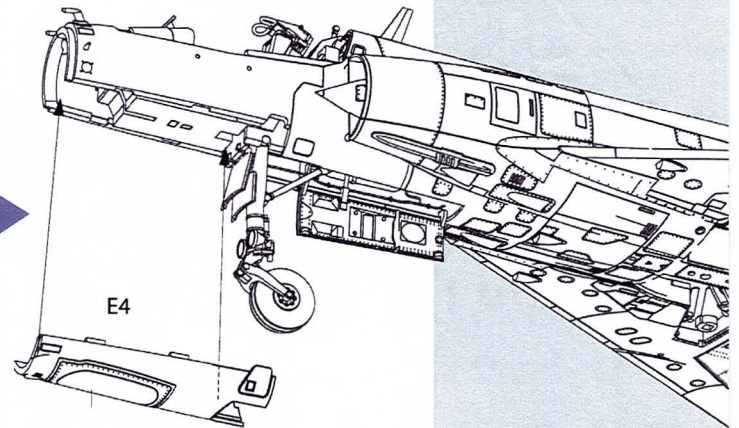

**19**

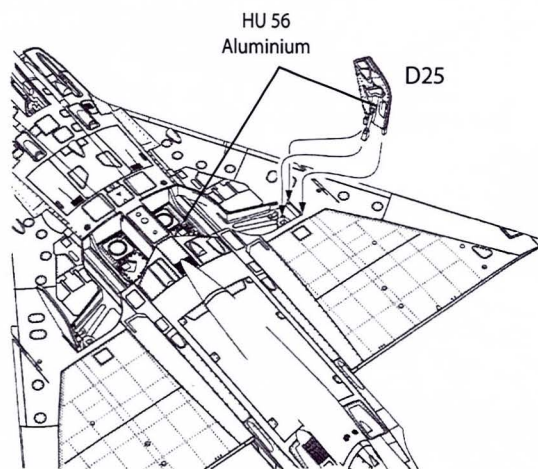
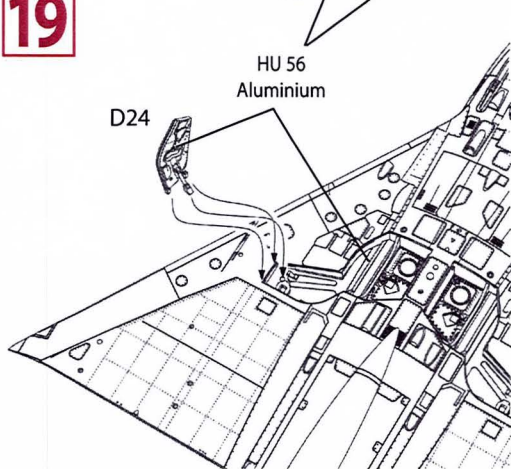

**20**

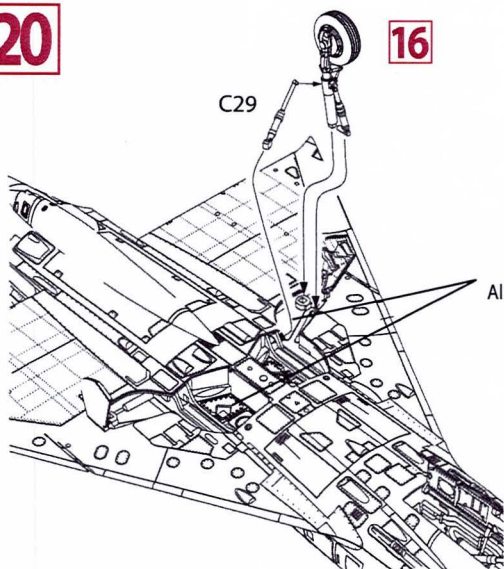

**16**

**16**

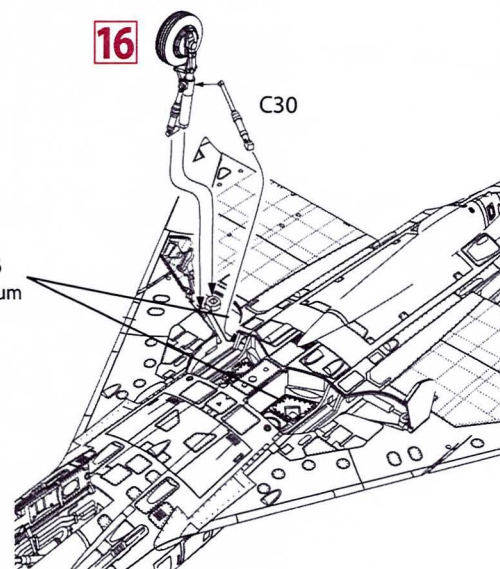

Paint front and main landing gear bays HU 56 Aluminium with some of the details in different colours. The insides of the landing gear doors were kept in the same colour – use HU 56 Aluminium for the whole undercarriage.



21

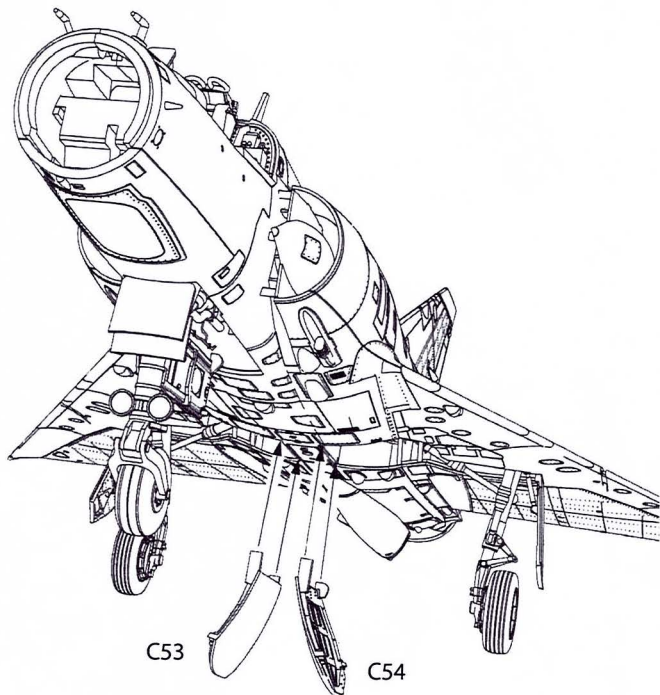

22

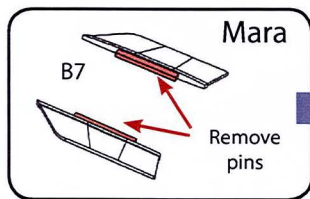
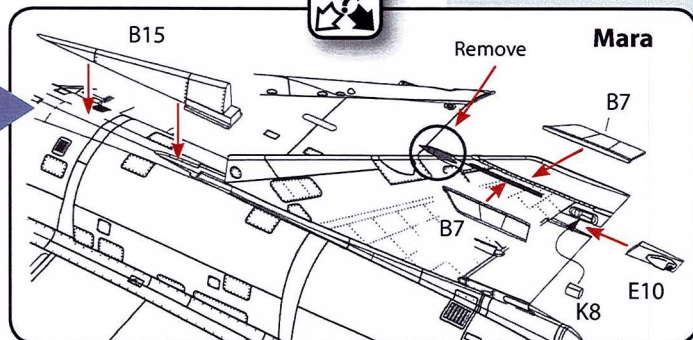
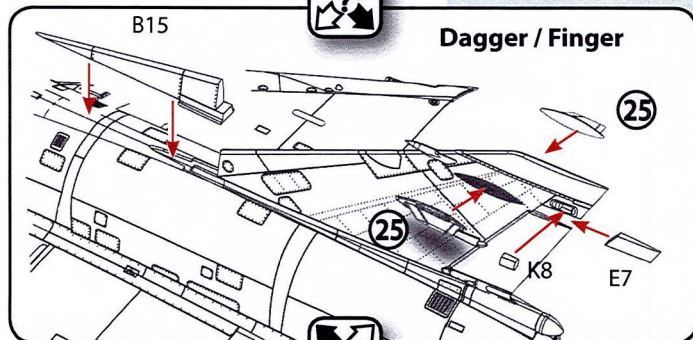
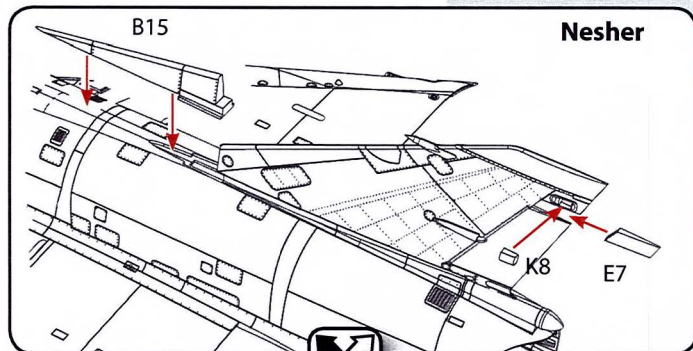

23

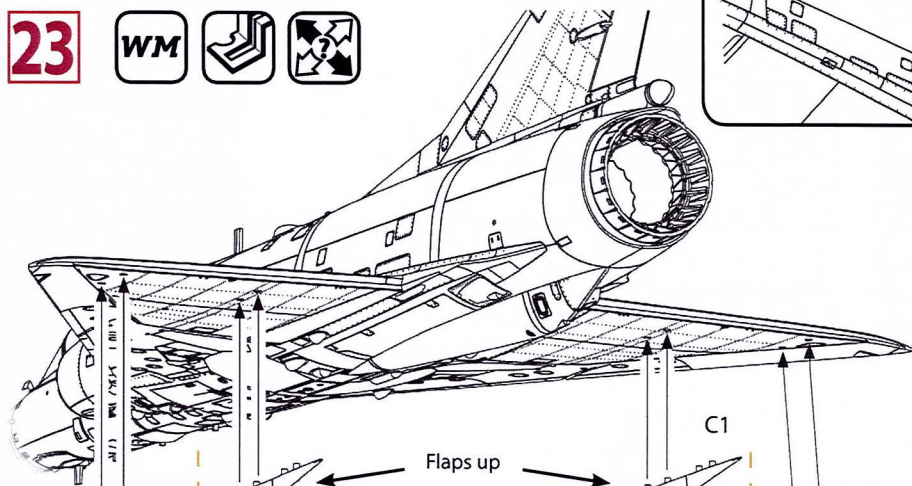

Without missile rail adapter

Flaps up

With missile rail adapter

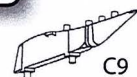

Flaps down

Flaps up

Flaps down

Flaps up

C9

C2

Flaps down

Without missile rail adapter

With missile rail adapter



Neshers, Dagers and Fingers did not feature an external RHAW gear, so part E7 must always be used when building one of these aircraft.

**Finger:**

Only one Finger (C-412 with the two ship silhouettes on the nose) served as a test bed for a RHAW gear installed into the Mara (ex-Peruvian Mirage 5P). After successful testing, the technical equipment was removed, however, the base for the antennas remain on the fin. Use part E10 but sand off the round bulbous antennas.

**Mara:**

All FAA Mara aircraft featured the above mentioned RHAW equipment – use part E10 exclusively for these aircraft.



24

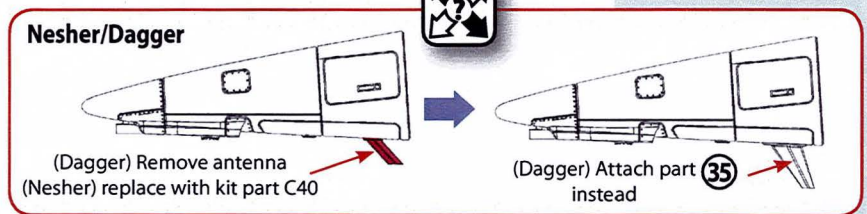
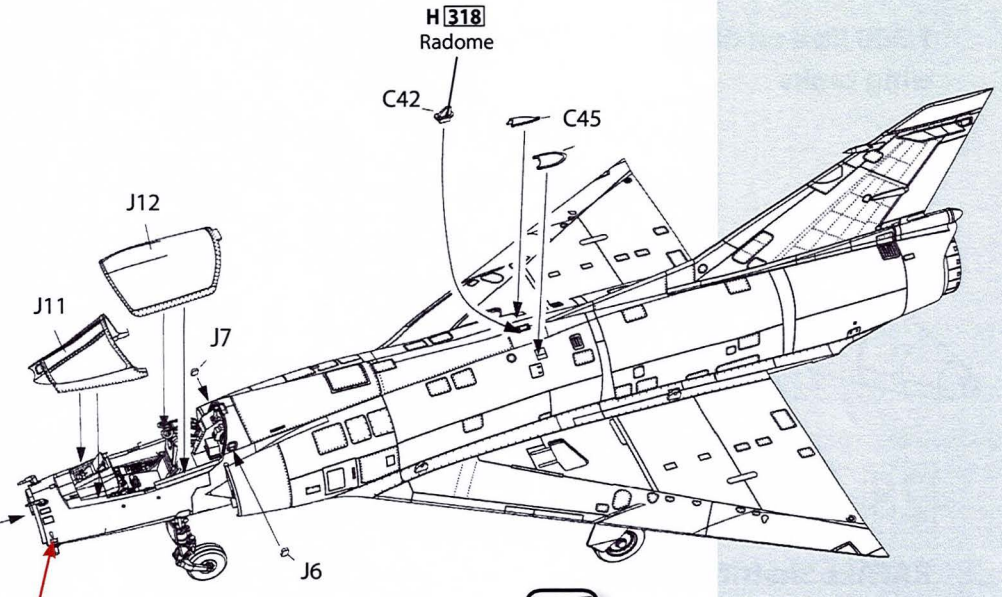
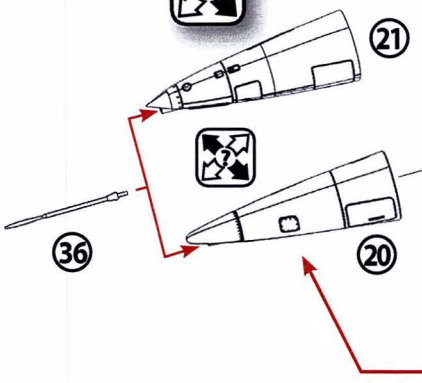
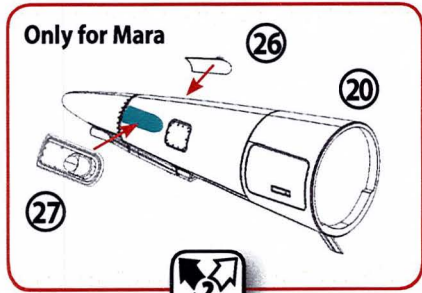

25



**Canopy masks**

**Etched parts inside the main canopy.**

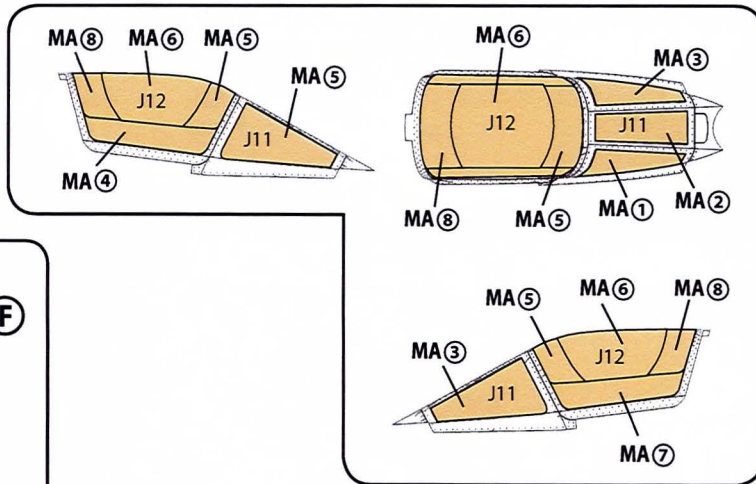
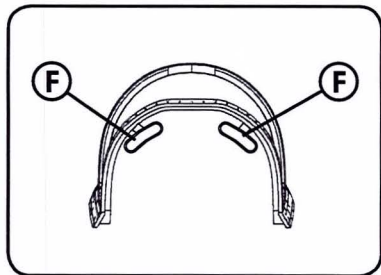

To replace Dagger aircraft that were lost during the Falkland War in 1982, Argentina decided to acquire ten Peruvian Mirage 5P. As the technical equipment proved to be inferior to that of the IAI Dagger, the FAA (Fuerza Aérea Argentina) decided to bring the Mirage 5P to Dagger standards and designate them Mara. The upgrades included the change of the nose cone and the additional installation of a RHAW gear.

To build a Mara use our resin parts 20, 26 and 27. Daggars and Maras had UHF blade-antennas on top of the spine as well below the nose - use our resin parts 35.

26

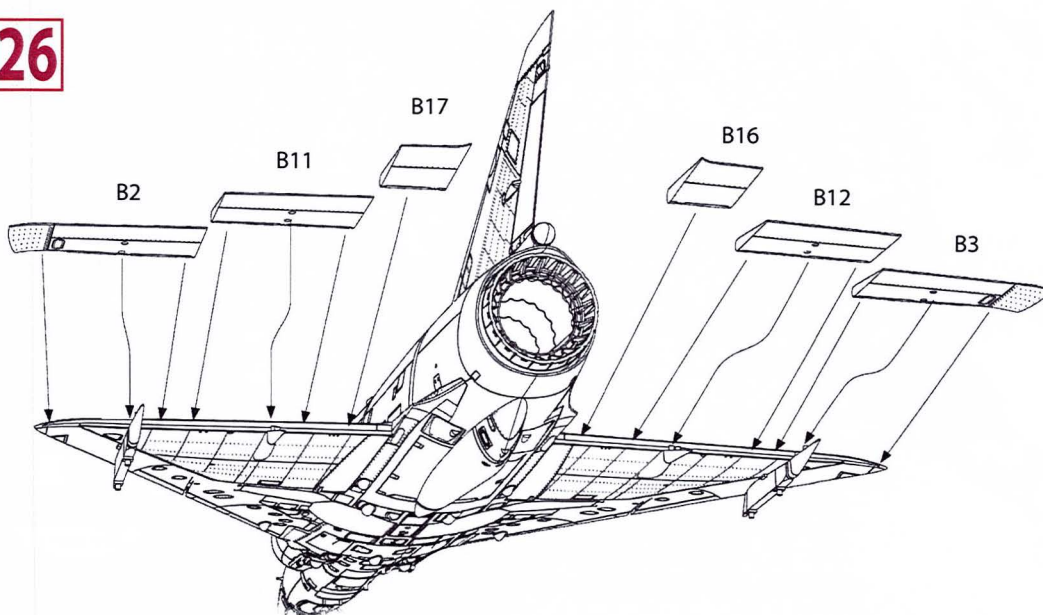



**27** WM X2

1,300 litre auxiliary wing tanks

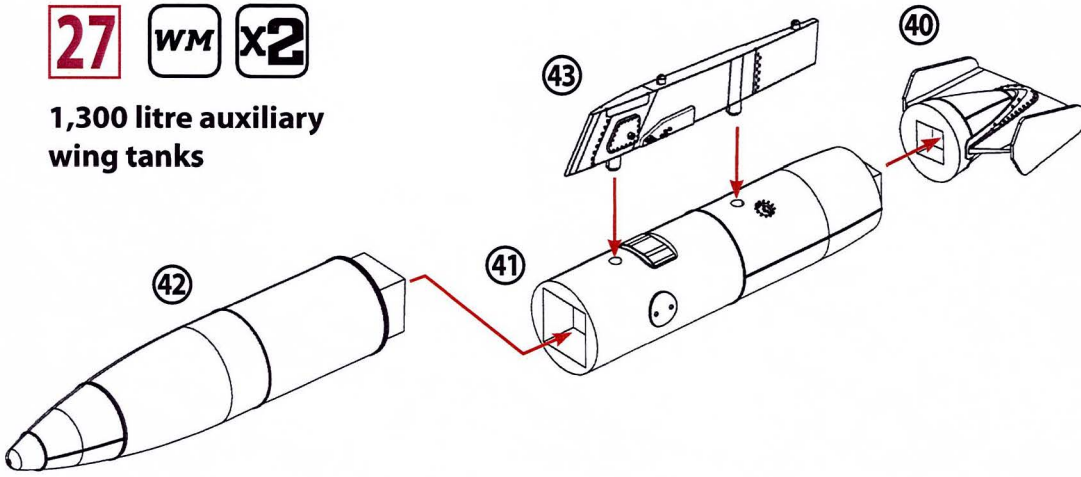

**28** WM X2

RAFAEL Shafrir 2 missile

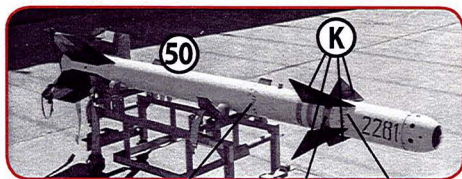
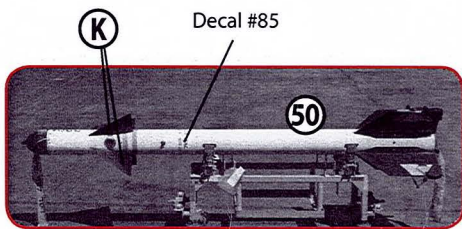

Decal #85      Decal #67      Decal #86



HU 56 Aluminium

(K) H 28 Metal Black

H 28 Metal Black

H 1 White

4 digits number  
Decal Type I

**29**

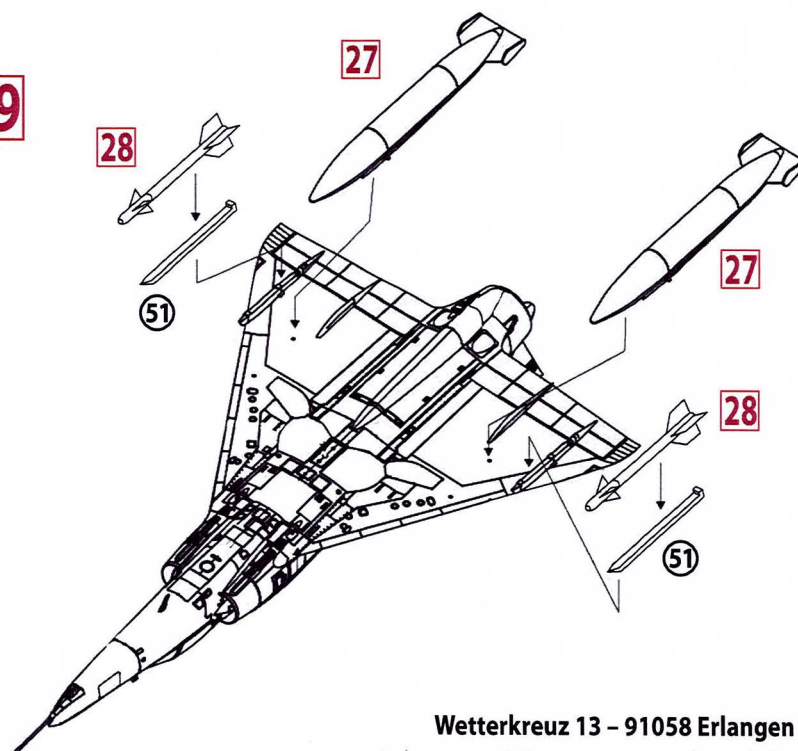

Wetterkreuz 13 - 91058 Erlangen - Germany  
www.wingmanmodels.com - www.shopofphantoms.com



We provide two highly detailed 1,300 litre - auxiliary wing tanks, relevant to that period of time and often carried during the 1970s and 1980s.



As main armament two highly detailed 'RAFAEL Shafrir 2' air-to-air missiles with rails are included in our kit.

These missiles were used with great success by the Israeli AF during the Yom Kippur War in 1973 and were also operated by the Argentinian Air Force, which had bought surplus 'Nesher' aircraft and operated those under the designation 'Dagger' during the 1980s.



Paint the missile body H 1 Glossy White and the fins H 28 Metal Black.

The colour of the missile rail as well as the YAW-rollers on the rear of the fins is HU 56 Aluminium.



We are right beside you!



# IAI Neshar/ Dagger/ Finger

## Colors and decals guide



*We are right beside you!*

### 1 Israeli AF Neshar No. 16, The Hornet Squadron, August 1973.

The Neshers entered service with the IAF in mid October 1971, first with 101 squadron. In early 1973, the Hornet squadron started receiving the Neshar and prepared to retire the veteran Ouragans. All the Neshers were painted similar to the Mirages that were in service. The existence of the Neshers were kept secret that time due the French embargo and the fact that the aircraft were assembled in Israel.

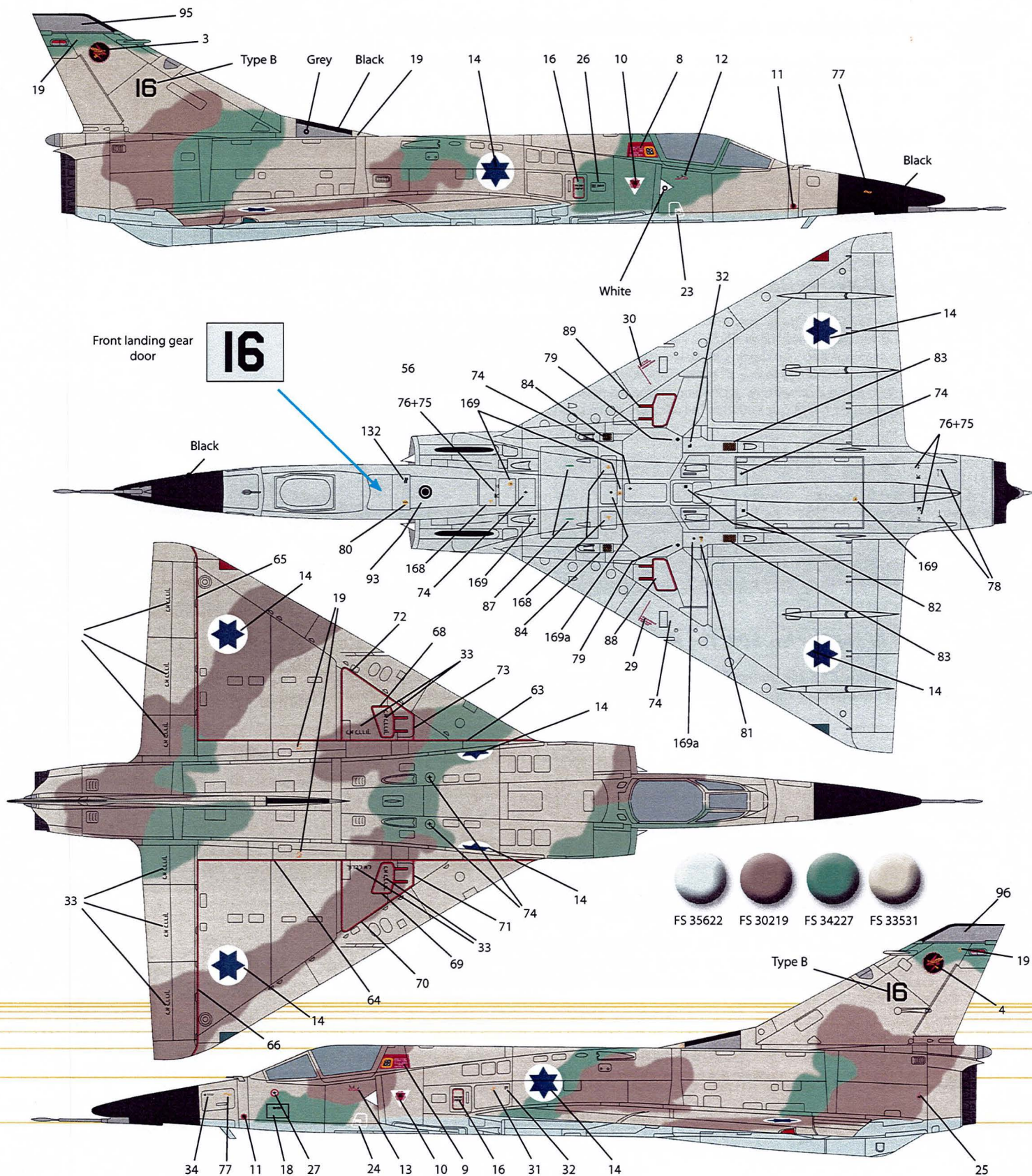



**2 Israeli AF Neshar No. 14, The First Fighter Squadron, 1972.**

The First Fighter Squadron was the first to operate the Neshers. The white and red stripes were painted on the plane's rudders. The unit was operating the Neshers parallel to the original Mirage IIIC/B that were in service since 1962.

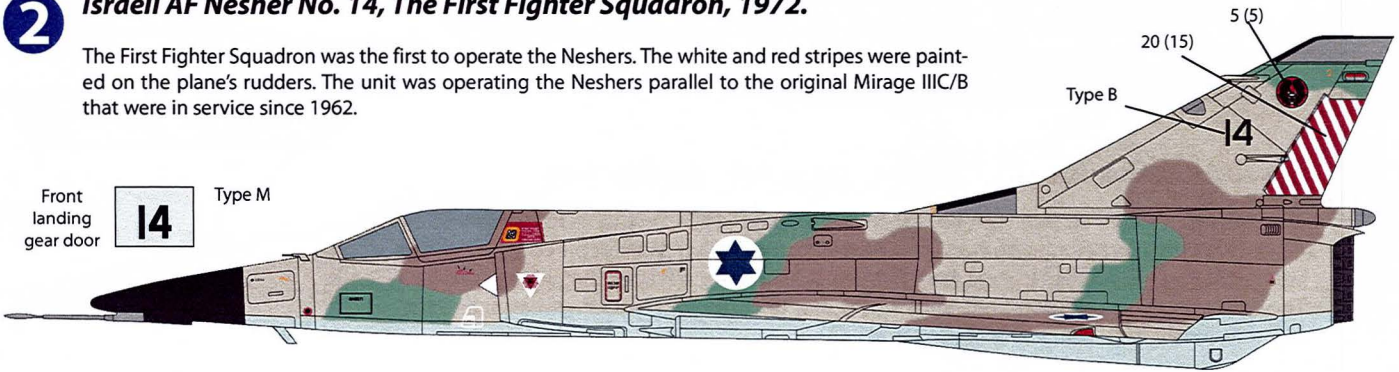

**3 Israeli AF Neshar No. 66, The Arava Gurandians Squadron, 1972.**

The Arava Guardians squadron were the 3rd unit to receive the Neshar as the first fighter squadron of Etzion AFB at the north-east corner of the Sinai peninsula.



**4 Israeli AF Neshar No. 517, The First Fighter Squadron, 1974.**

During the 1973 Yom Kippur war, Yellow and Black triangles were painted on all delta fighters on their wings and vertical fin. and the prefix 5 was added. Each base painted them differently. We providing 2 sets of wing's markings and 3 for the fins. If you wish to model a different aircraft, please check your references to decide which markings to use. In some cases you may need to cut the decal since in some cases the aircraft were painted differently, depending on the tail number location. After the war the prefix 5 was added to the all single seat aircraft while the two seaters received the prefix 6.

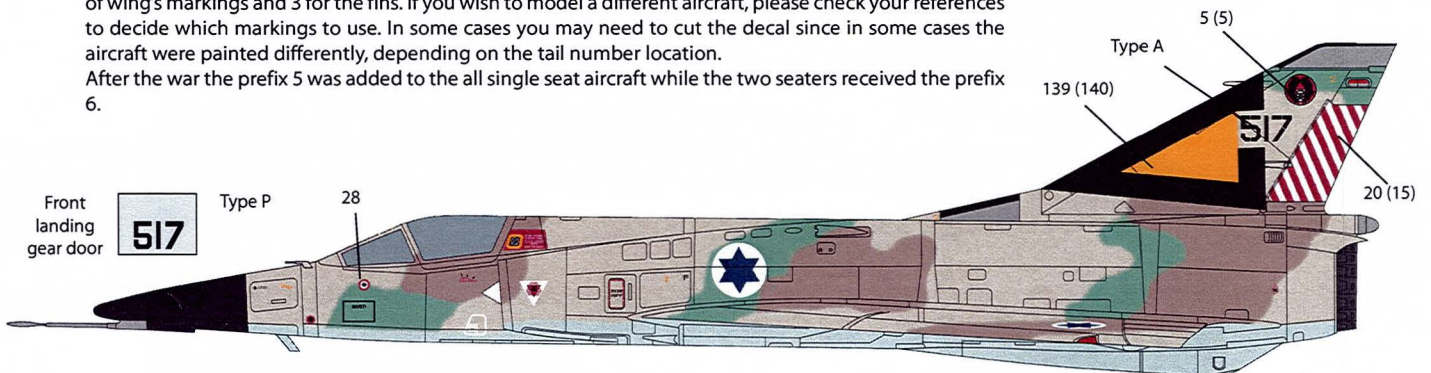

**5 Israeli AF Neshar No. 509, The Hornet Squadron, 1974.**

Neshar 09 claimed 7.5 kills during the YKW, but 8 were painted (the half kill was decided later by the IAF intelligence). The unit painted their rudder with yellow and black checkers.

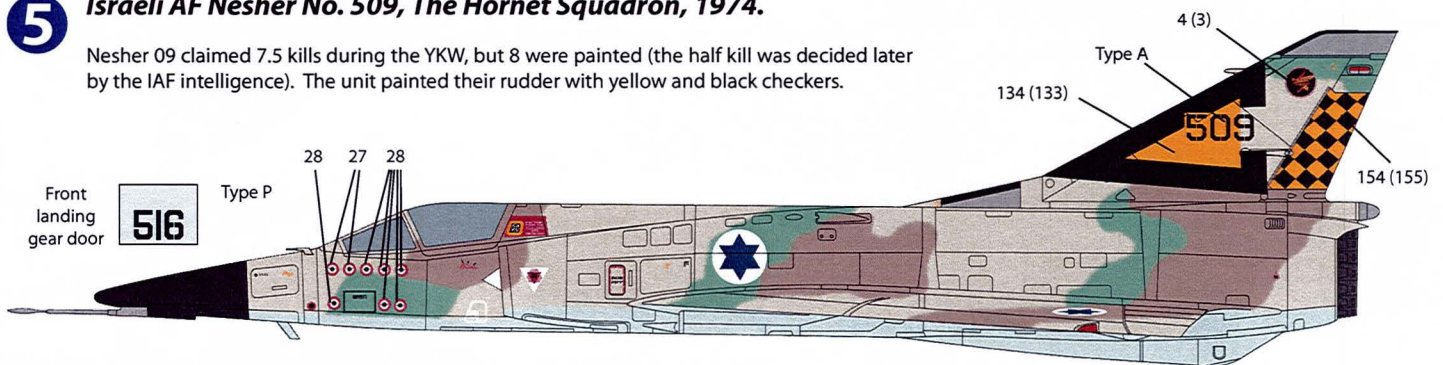

**6 Israeli AF Neshar No. 516, The Negev Squadron, 1977.**

When the Kfirs arrived in 1975, the First Fighter squadron transferred their Neshar to the Hornet squadron. When the later received the Kfirs as well, a new squadron, "The Negev" squadron was formed at the new base of Eitam at the north part of the Sinai peninsula. The previous marking were kept until they were painted over.

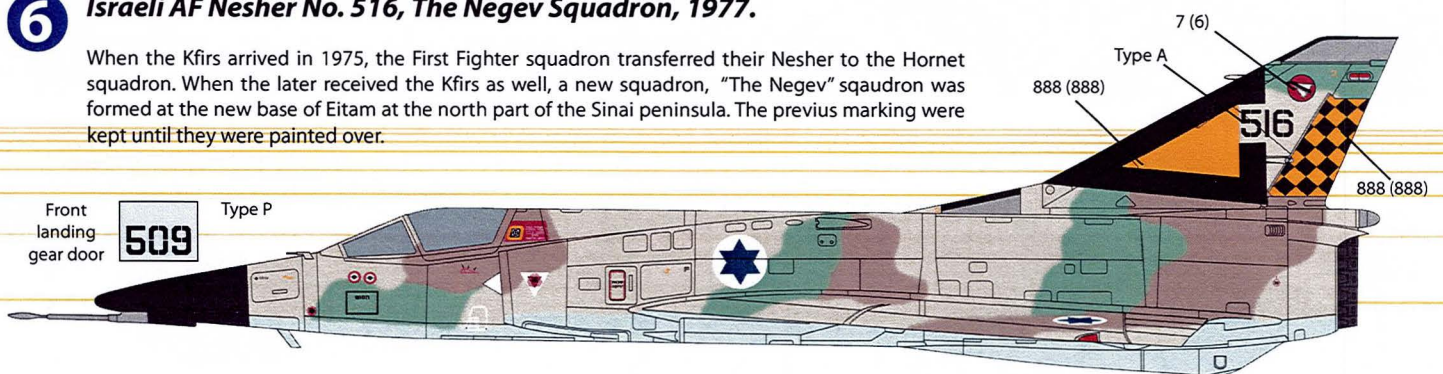



**4 5 6**

This style of the painted yellow and black triangle, is the type used on Hatzor painted Neshers as well as the ones painted by the Israeli Aircraft Industries on aircraft that arrived after the war.

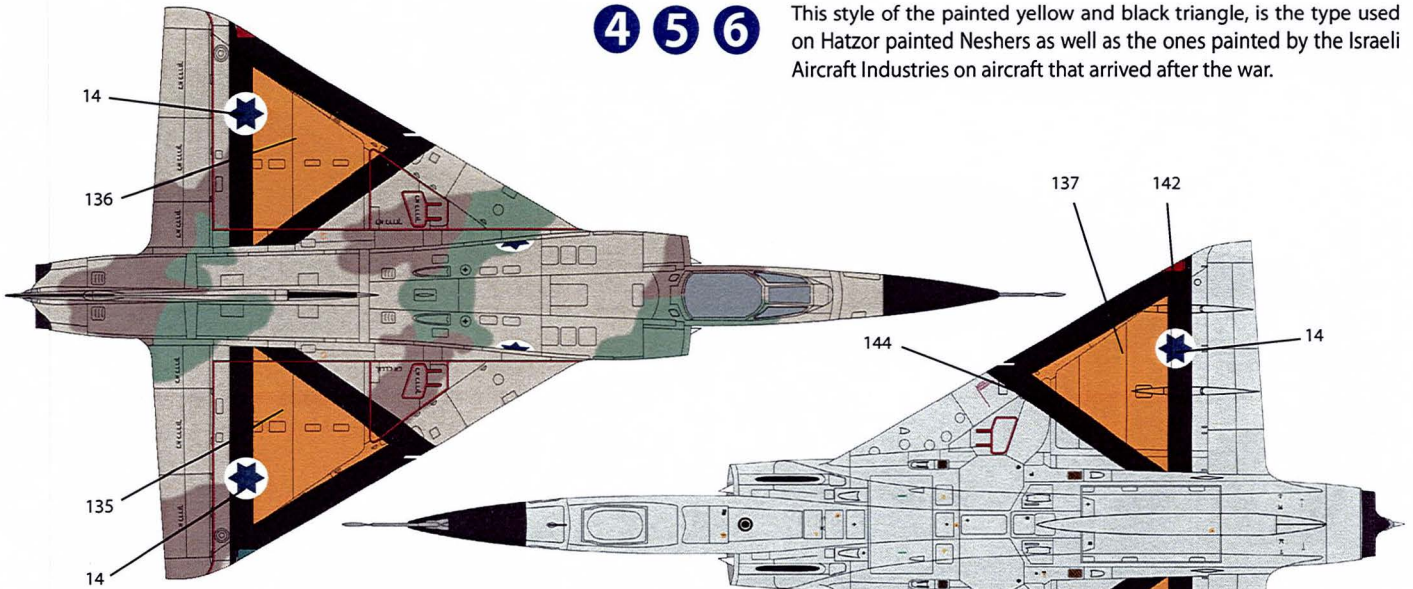

**Style painted by IAI**

Front landing gear door **572** Type O

**Style painted at Hatzor**

Front landing gear door **573** Type P

**7 Israeli AF Nesher No. 524, The Arava Gurandians Squadron, 1976.**

The triangles that were painted on the Neshers at Etzion AFB, were different. This aircraft was painted with 4 kill marks of Egyptian MiGs that were shot down during the YKW.

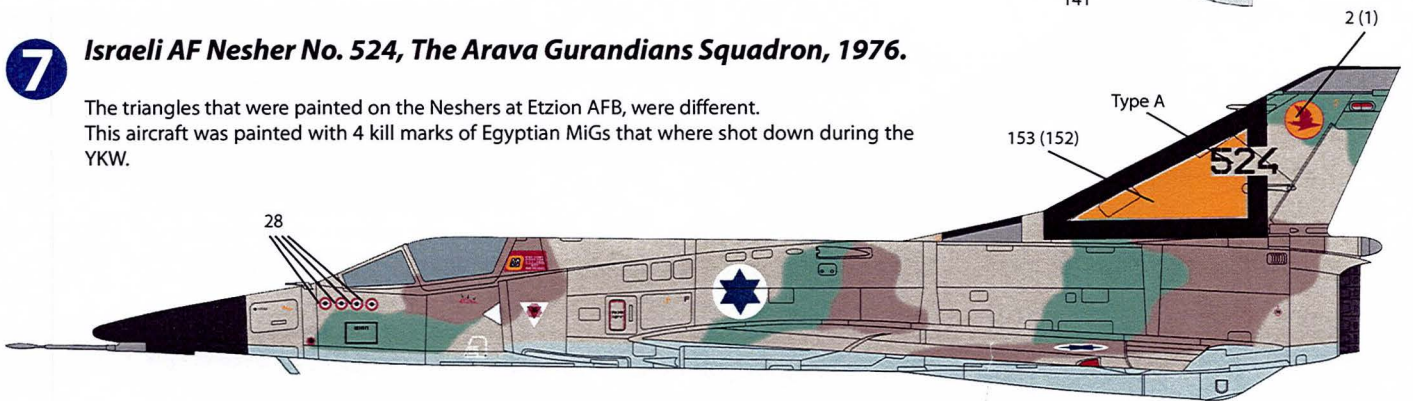

**Style painted at Etzion**

Front landing gear door **524** Type L

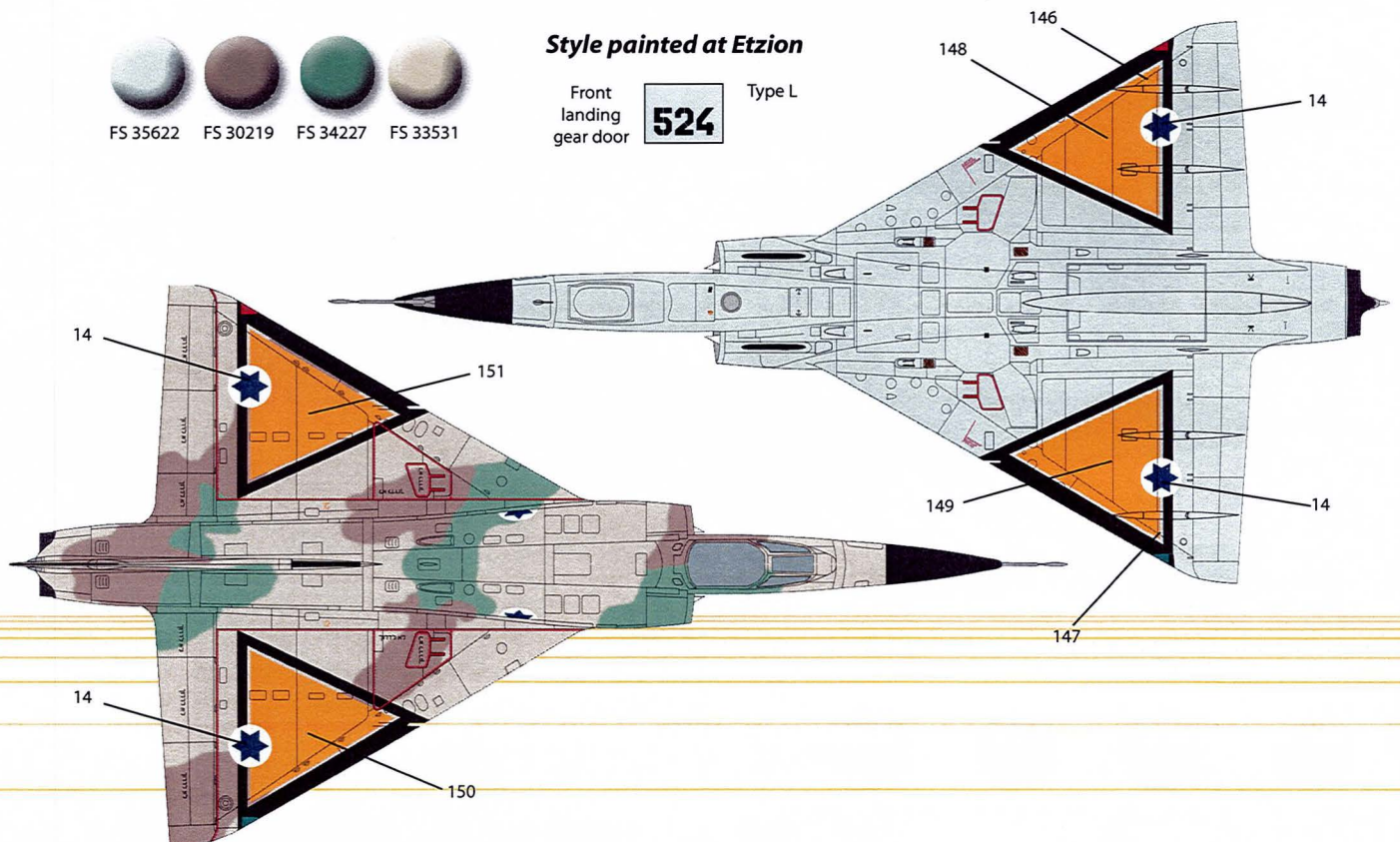



8

Fuerza Aérea Argentina, Dagger C-401, VI Brigada Aérea, Grupo 6 de Caza, 1980

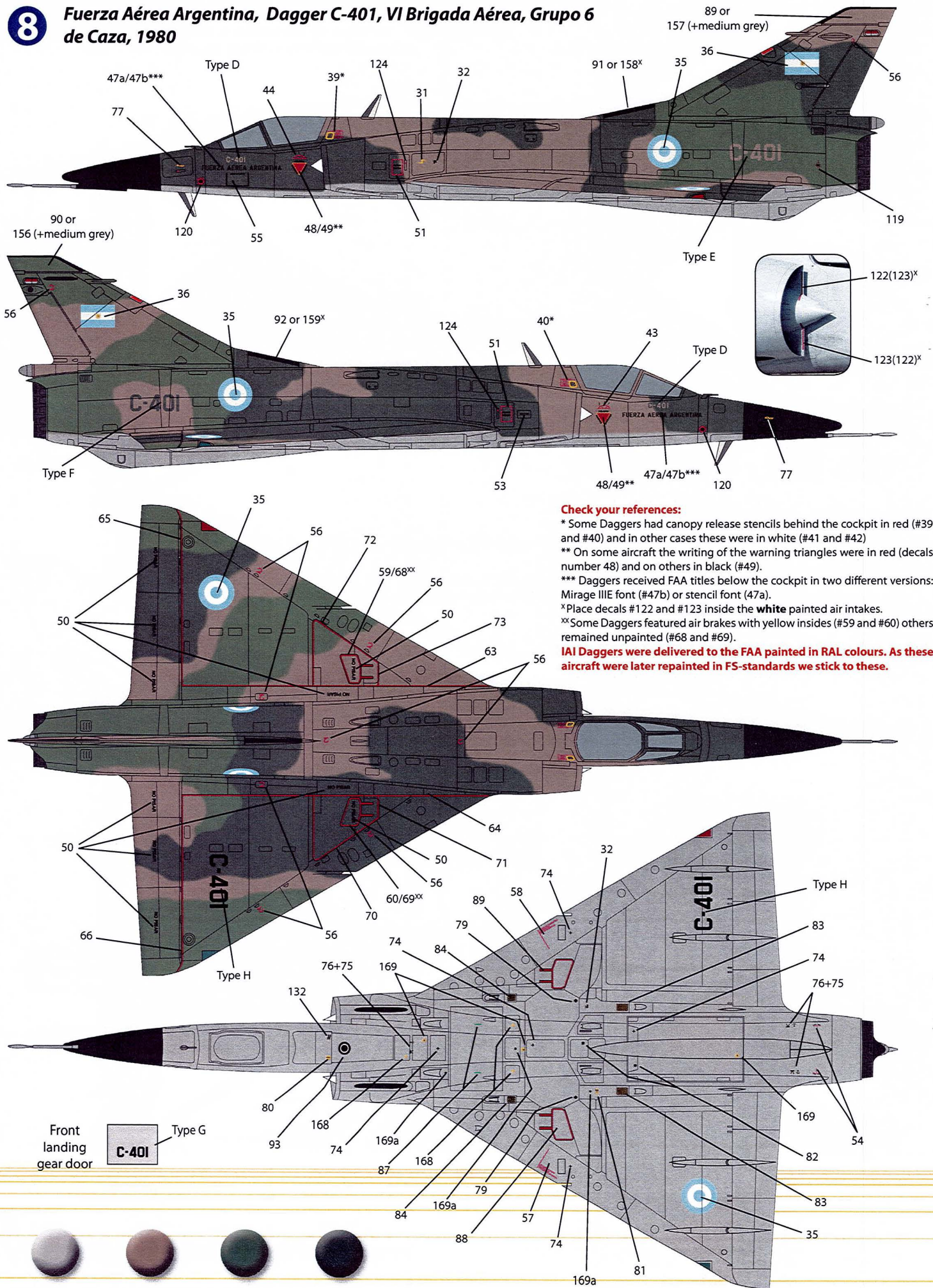

Check your references:

\* Some Daggers had canopy release stencils behind the cockpit in red (#39 and #40) and in other cases these were in white (#41 and #42)

\*\* On some aircraft the writing of the warning triangles were in red (decals number 48) and on others in black (#49).

\*\*\* Daggers received FAA titles below the cockpit in two different versions: Mirage IIIE font (#47b) or stencil font (47a).

\*Place decals #122 and #123 inside the white painted air intakes.

\*\*Some Daggers featured air brakes with yellow insides (#59 and #60) others remained unpainted (#68 and #69).

IAI Daggers were delivered to the FAA painted in RAL colours. As these aircraft were later repainted in FS-standards we stick to these.

4

Mr. Hobby H 311 Mr. Hobby H 310 Mr. Hobby H 303 Mr. Hobby H 309



**9** *Fuerza Aérea Argentina, Dagger C-410 VI Brigada Aérea, G6C, Tandil, 1983*

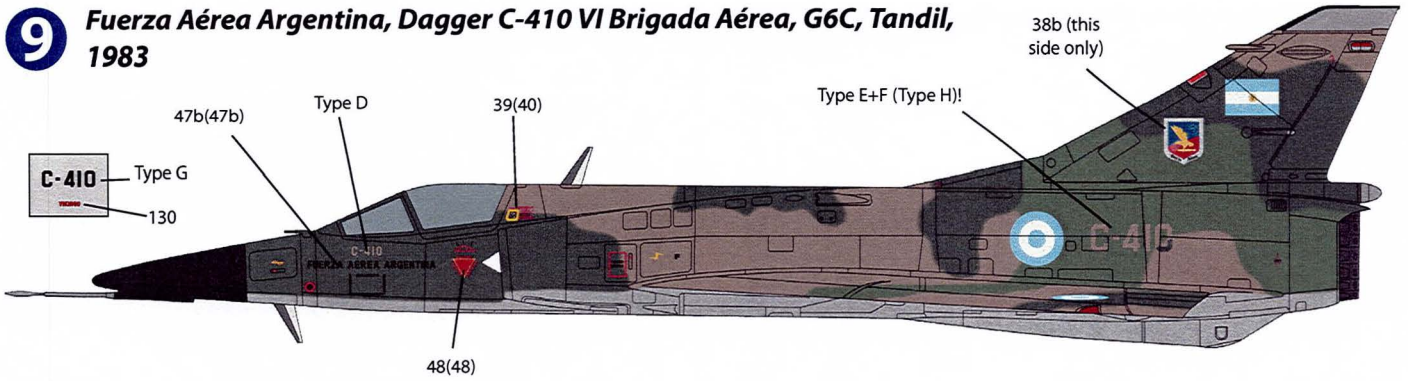

**10** *Fuerza Aérea Argentina, Dagger C-419 VI Brigada Aérea, G6C, Tandil, 1981, (shot down on May 24, 1982)*

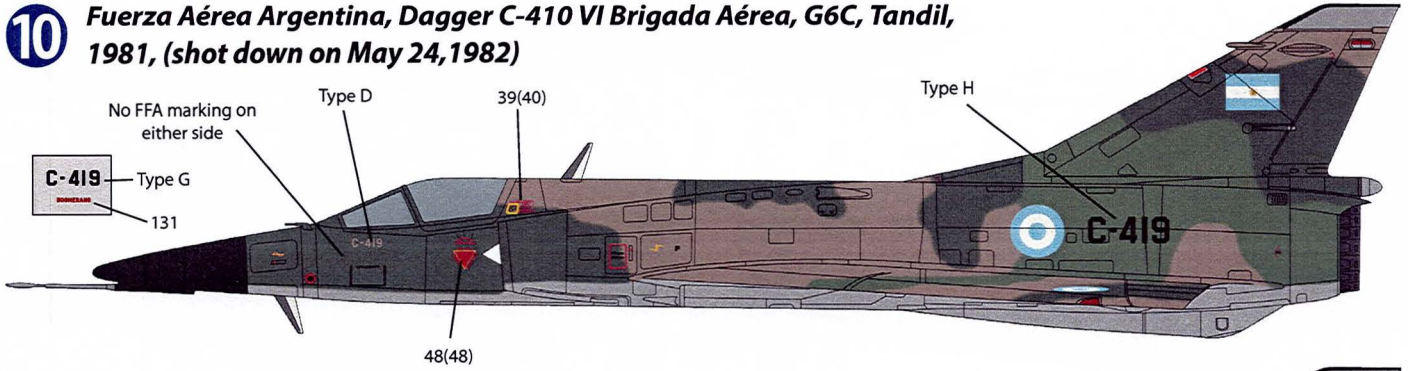

**11** *Fuerza Aérea Argentina, Dagger C-420 VI Brigada Aérea, G6C, II Escuadron "La Marinete", BAM San Julián, 1982*

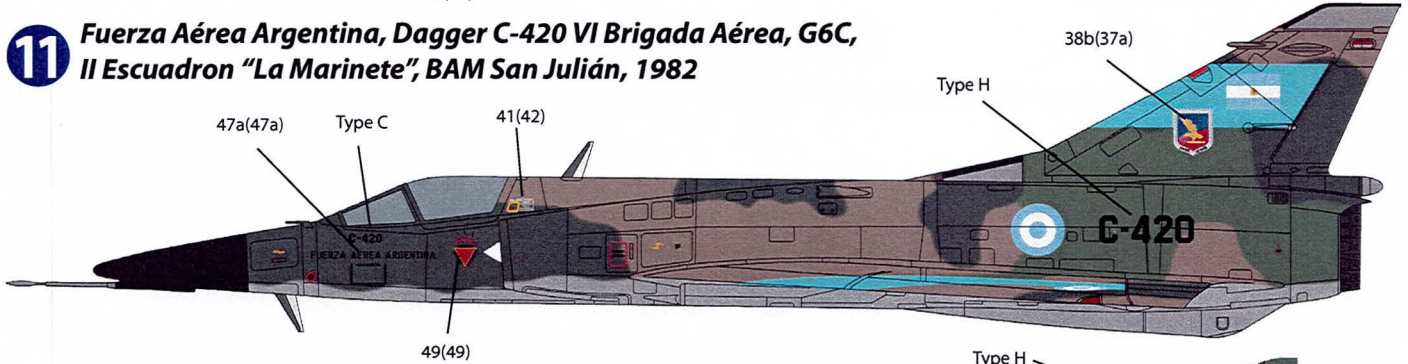

FAA Daggers featured three different colours for their tactical codes on the rear fuselage. These were either Black, Tan or Dark Green. Black codes were more dominant, however on several Daggers the codes were applied in Tan when the background was in Dark Green (decals Type E) and painted in Dark Green when the background was Tan (decals Type F).

**12** *Dagger C-437 VI Brigada Aérea, G6C, I Escuadron "Avutardas Salvajes" Base Aeronaval Hermes Quijada, Río Grande, 1982*

During the Falkland (Malvinas) War, Daggers received ID-markings on top of the wings and fins, with a small number also having them under the wings. Drop tanks received a deeper yellow, possibly due to the irregular source of paints, which were purchased at a local paint shop. In late May 1982, the ID-bands were painted over with a turquoise green as dark green was unavailable. Towards the end of the conflict, Dagger ID bands were over sprayed with tan or green.



~ FS 13507

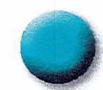

~ FS 15200

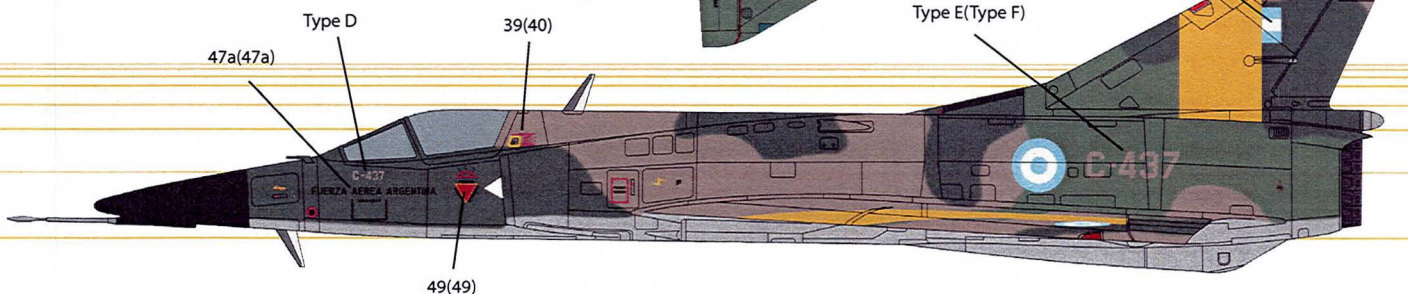
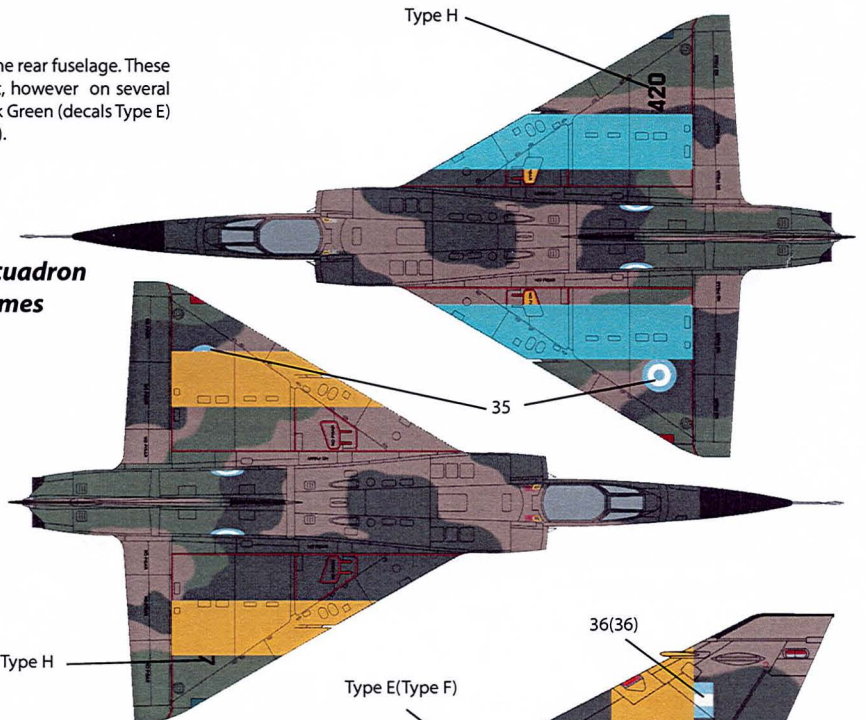



**13** Fuerza Aérea Argentina, Dagger C-414 VI Brigada Aérea, G6C, Tandil, 1983

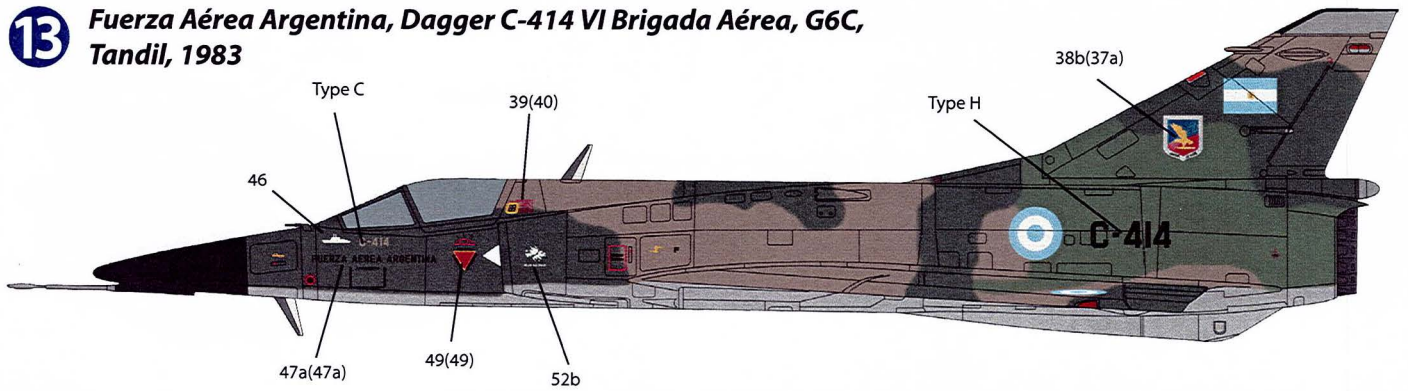

Fuerza Aérea Argentina, Dagger C-432 VI Brigada Aérea, G6C, BAM Tandil, 1981

**14**

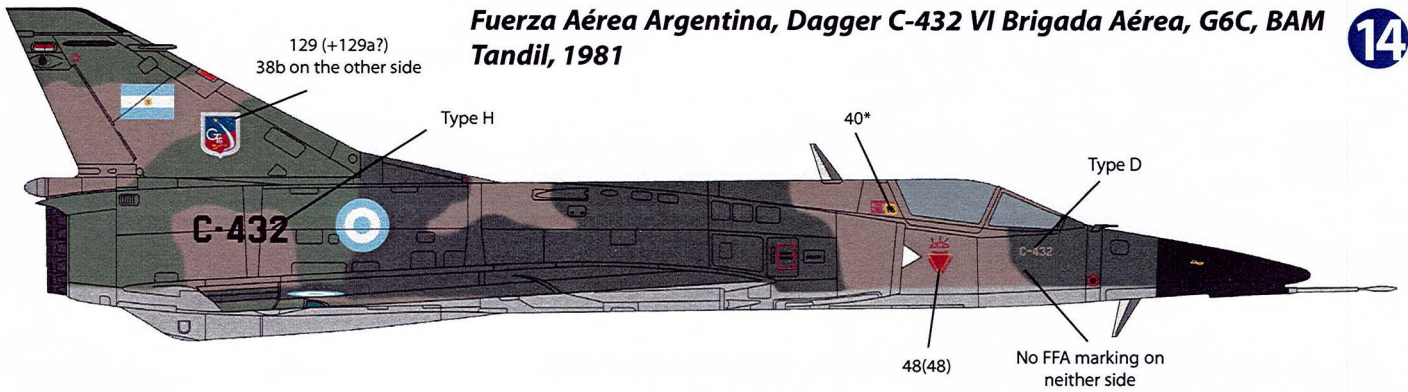

**15** Fuerza Aérea Argentina, Dagger C-412 VI Brigada Aérea, G6C, BAM Tandil, 1983

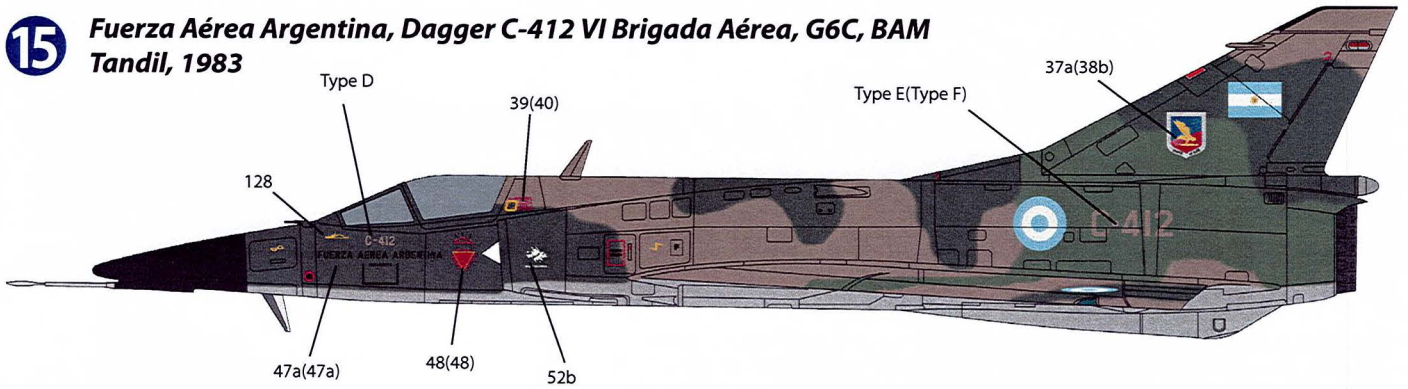

Fuerza Aérea Argentina, Dagger C-434 VI Brigada Aérea, G6C, BAM Tandil, late 1982

**13**

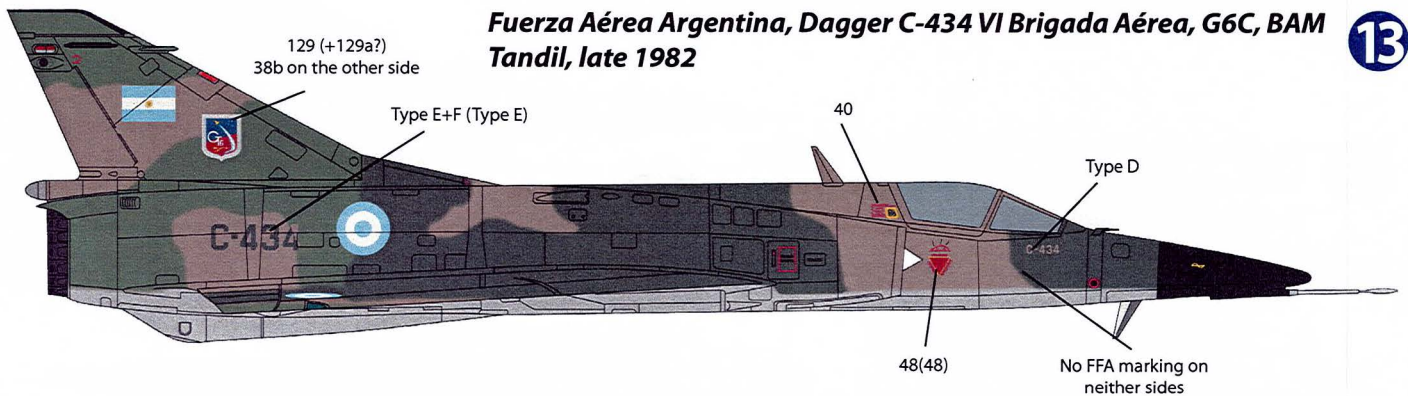

**16** Fuerza Aérea Argentina, Dagger C-415 VI Brigada Aérea, G6C, BAM Tandil, 1983

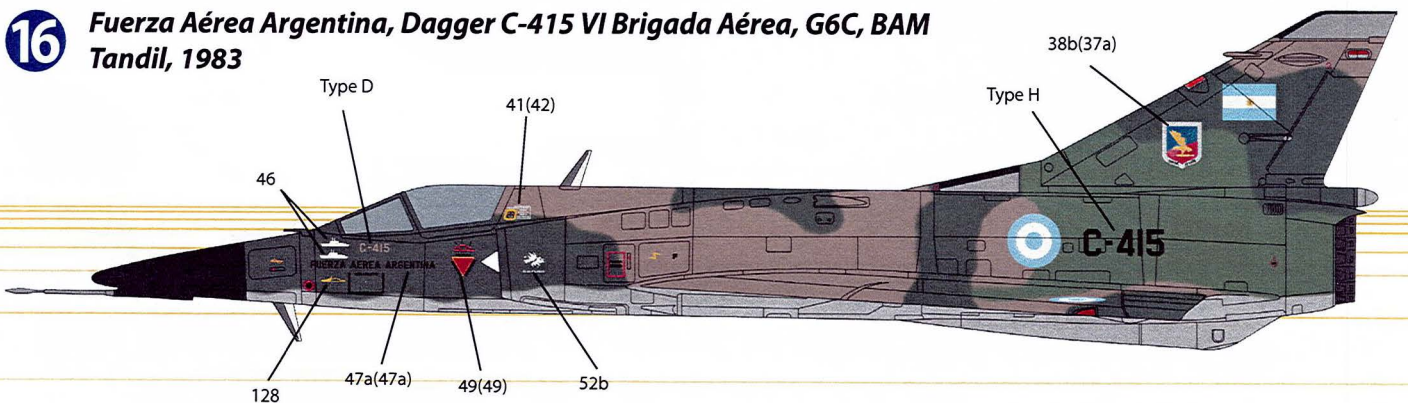

**6**



**17** Fuerza Aérea Argentina, Dagger C-418 VI Brigada Aérea, G6C, BAM Tandil, 1984

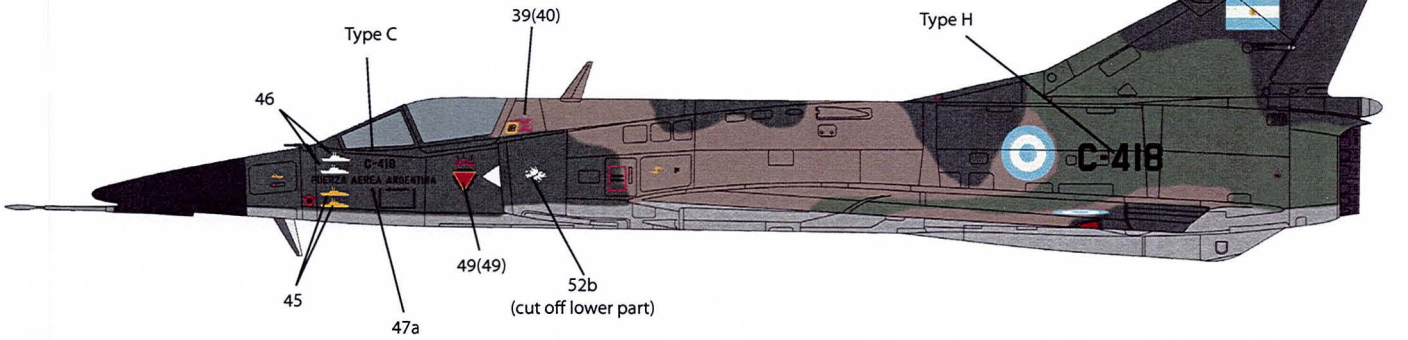

**18** Fuerza Aérea Argentina, Finger I C-405 VI Brigada Aérea, G6C, BAM Tandil, 1983

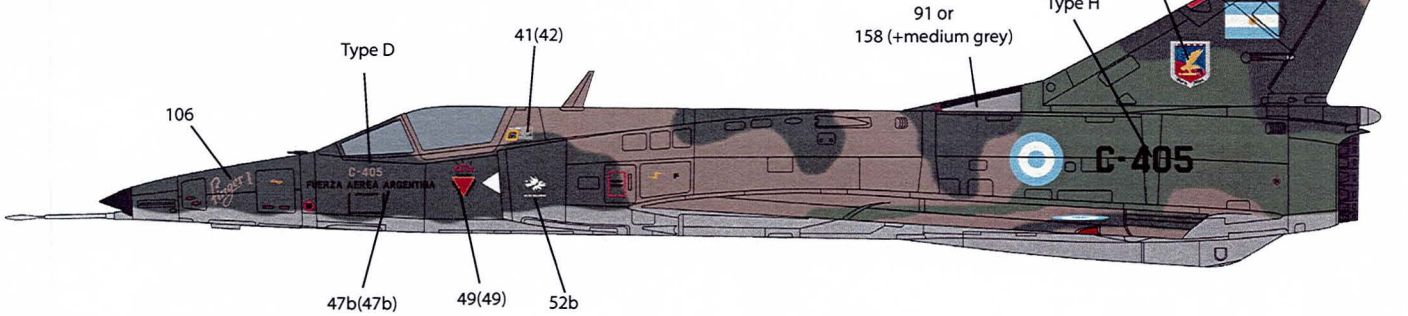

**19** Fuerza Aérea Argentina, Finger IIIA C-408 VI Brigada Aérea, G6C, BAM Tandil, circa 1984

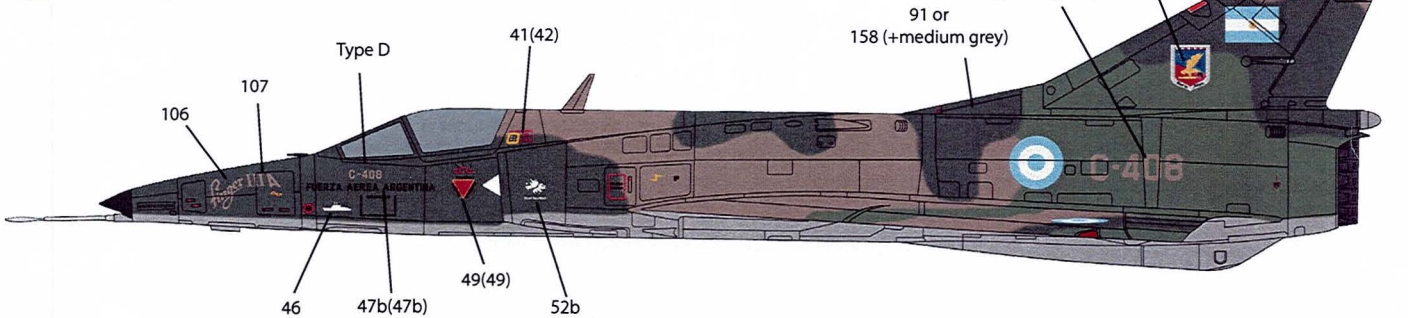

**20** Fuerza Aérea Argentina, Finger IIIB C-412 VI Brigada Aérea, G6C, BAM Tandil, early 2010

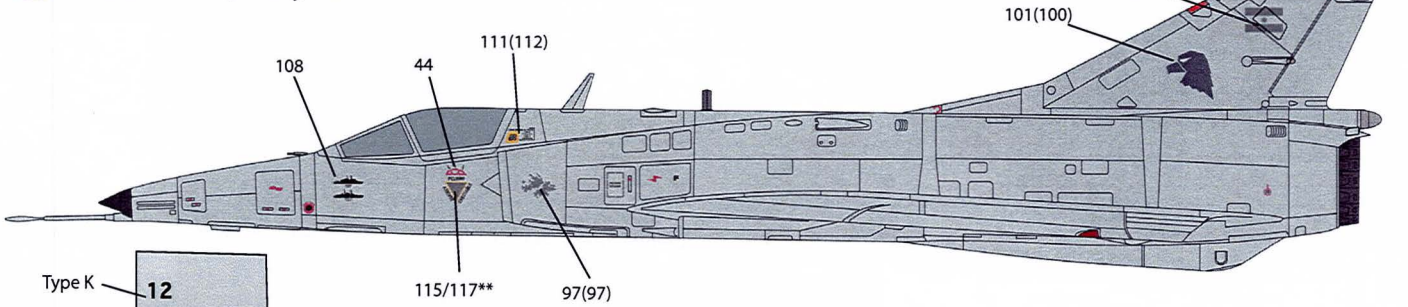

Inside main front landing gear door

**21** Fuerza Aérea Argentina, Finger IIIB C-420 VI Brigada Aérea, G6C, BAM Tandil, 2012

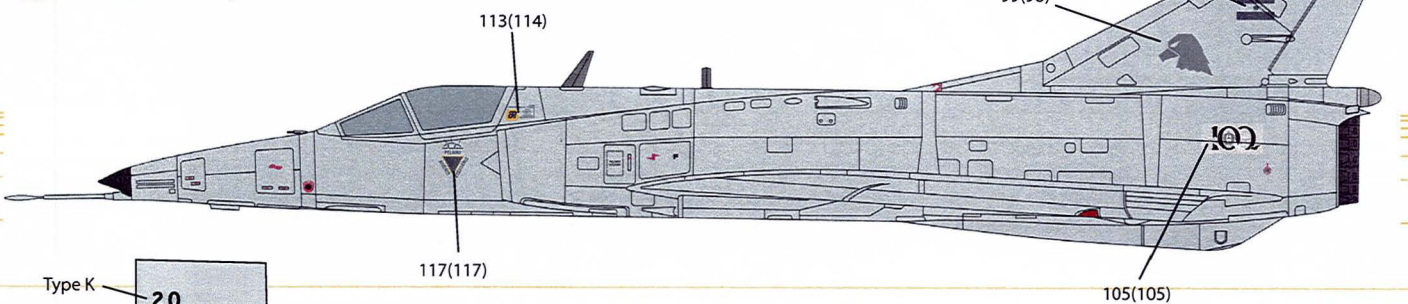

Inside main front landing gear door











Finger, Mara, Mirage III EA single-tone grey camouflage

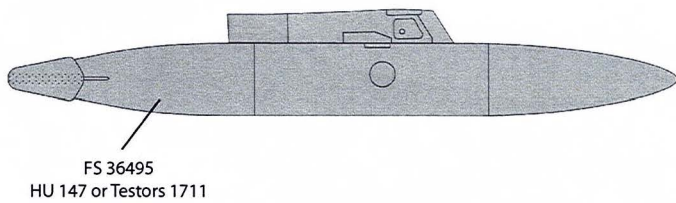

Paint scheme of tanks received from Peru

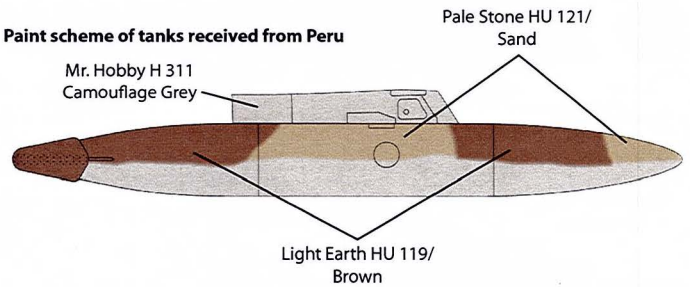

Falkland War standard Dagger tank with Orang Yellow ID

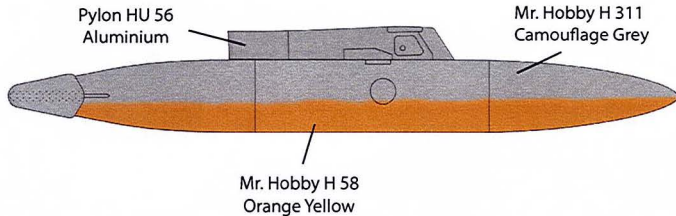

Falkland War standard Dagger tank with Turquoise ID

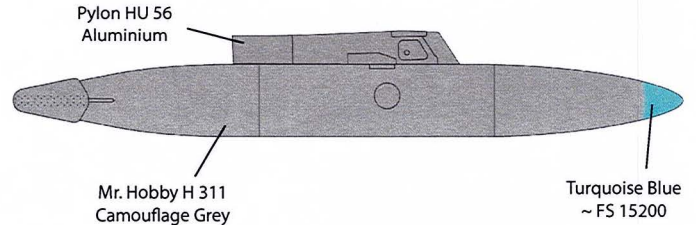

### FAA Dagger / Finger / Mara Colours and Markings:

#### Dagger

IAI Daggars were delivered from Israel in a SEA-like camouflage scheme, but using distinctive RAL colours. These were RAL 1019 Graubeige, RAL 6003 Olivgrün, RAL 6015 Schwarz Olive and RAL 7047 Telegrau 4 – all with a satin finish. Equivalents were the usual Federal Standard paints FS 36622 Camouflage Grey, FS 30219 Dark Tan, FS 34102 Medium Green and FS 34079 Dark Green. Several aircraft sported the delivery colour for a number of years. After overhaul or repairs, they were repainted with matt paint, which faded and chipped considerably.

During the Malvinas (Falklands) conflict, ID-bands were applied in a shade that resembles Insignia Yellow. The bottom parts of the auxiliary wing tanks were usually painted in a darker shade of yellow, similar to Mr. Hobby H58 Orange Yellow. Turquoise was painted over the yellow after the latter was found ineffective.

#### Mara

Mirage 5P aircraft, later re-designated Mara, were supplied by Peru to Argentina in their original sand-brown scheme, which was later repainted using more unique tan and light green colours. For the 'sand or light tan' colour you could use either HU 93 Desert Yellow or HU 118 Tan. The green, however, has been subject of much speculation as paints were mixed in a non-standard manner – several variations are known to have existed. Try Humbrol paints HU 76 or Hu 78 as light olive is a close match. You can mix according to your own taste as sometimes the light green had a blue hue. Under surfaces were painted in light grey – we suggest to use Humbrol 147 or better even, Testors 1233 Light Aircraft Grey.

#### Finger

Both Fingers and Maras alongside the surviving Mirage III EA aircraft adopted a single-tone light grey scheme, sometimes dubbed "anonymous" as the only way to determine their identity is to look inside the main landing gear bay door and check the two-digit aircraft code. Again, shades could vary considerably as earlier Mirages were of a darker shade (similar to FS 36375) and later adopted a close match to FS36495 which equals Humbrol HU 147 or Testors 1711.

Juan Contreras

*Special thanks to  
Santiago Cortelezzi and  
Juan Contreras for the  
immense help in our  
research!*



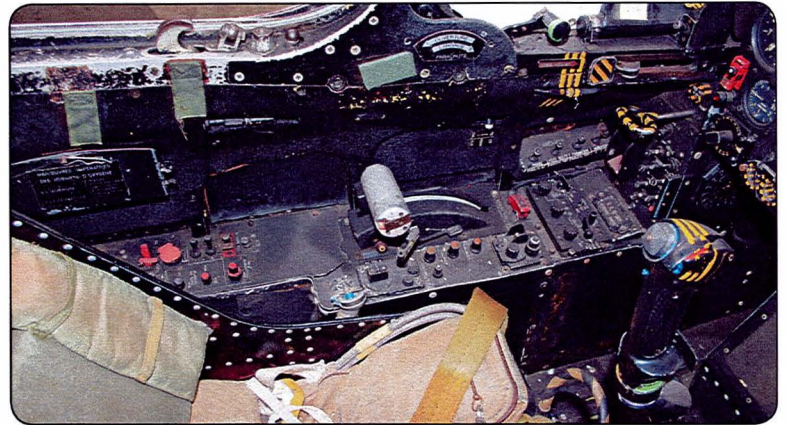
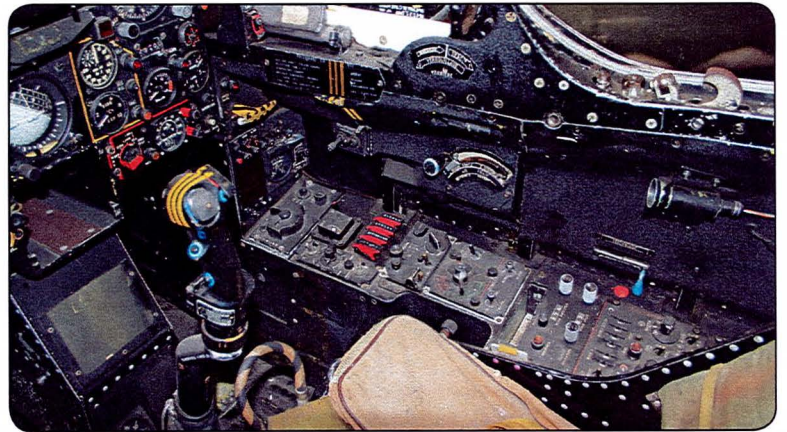

Typical Mirage 5/Nesher cockpit layout with all black cockpit tub, side walls and seat. Seat cushion in Khaki. (Photos AirDOC)

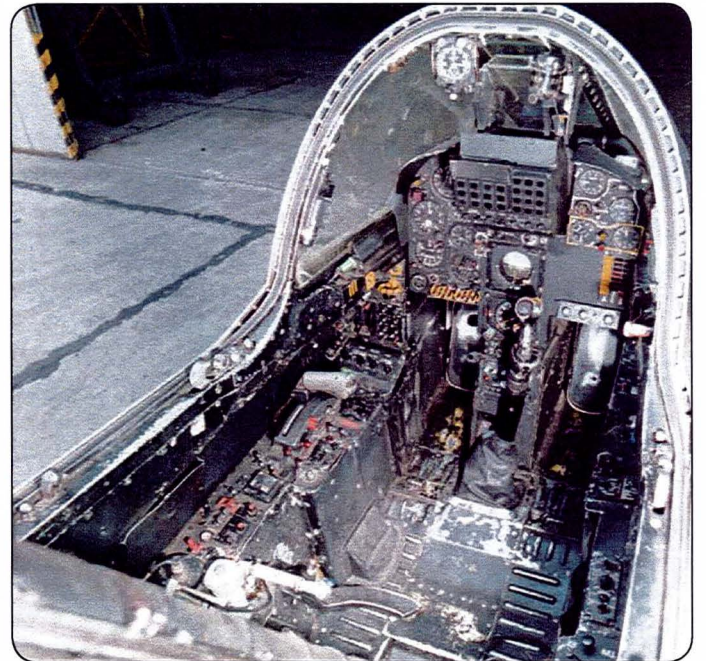

Top and right: Revised Finger IIIB cockpit with new HUD – still painted all black.  
 Bottom left: RHAW-gear on the nose (Mara only) and antenna arrangement (spine) typical for Mara and Finger aircraft.  
 Bottom right: Finger C-412 with late style two-digit aircraft code inside the front landing gear bay door. (Photos Santiago Cortelezzi)

