



The BA64B

The BA-64 was nicknamed the "Bobik" by its crews. It had good traction but the chassis was narrow and top heavy which made it prone to overturning on rough terrains. It was tight internally and had a crew of two. One driver and a commander who also operated the machine gun.

The production program for the BA-64 started in July 1941 and was manufactured by the GAZ factory. It was introduced to the Red Army in the year of 1942. The BA-64 used the same chassis as the GAZ-64 light jeep. The design was influenced by Germany's Sdkfz 222 armored car had sloped armor. It, depending on location, had 4mm to 15mm of armor thickness. This gave it better protection.

A small turret was fitted on the hull and was armed with a 7.62mm DT machine gun. The machine gun ring allowed it a 360 degree rotation and the gun could be angled at a high angle of elevation. This made it possible to engage with enemy troops located in tall buildings. 1260 rounds were carried for the gun. These superior qualities made ideal for urban combat mission.

After the BA's mass production an improvement program started to solve the problem of its proneness to overturning. The result was the BA64B. It was based on the GAZ-67B light jeep's chassis having a wider wheelbase, plus 2 shock absorbers. This improved its steadiness and handling.

Most of the BA64's served in reconnaissance units and as command cars. It was also used for infantry fire support missions. The BA-64s and BA-64Bs served in all fronts during WWII. After the war the BA-64s and 64Bs also served in Poland, East Germany and Czechoslovakia, some were sent to China and North Korea. A total of 9110 units were manufactured.

Assembly

1

body color: Russian green
or
Olive drab

A

B27

B28

B29

Flat black

B21

B31

Metallic grey

A

B6

B20

B8

B32

B9

B7

2

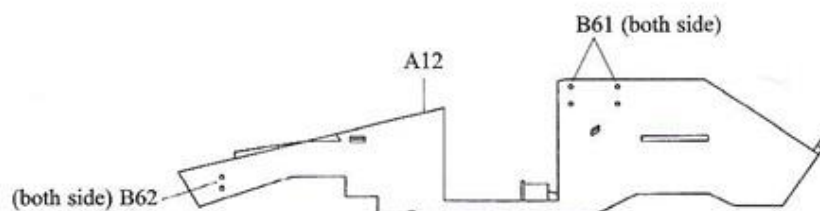
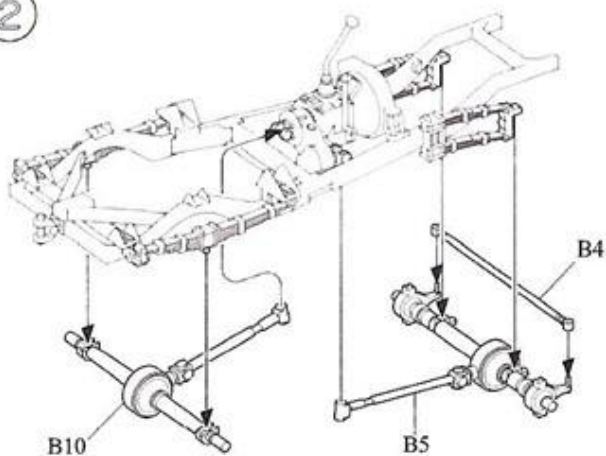

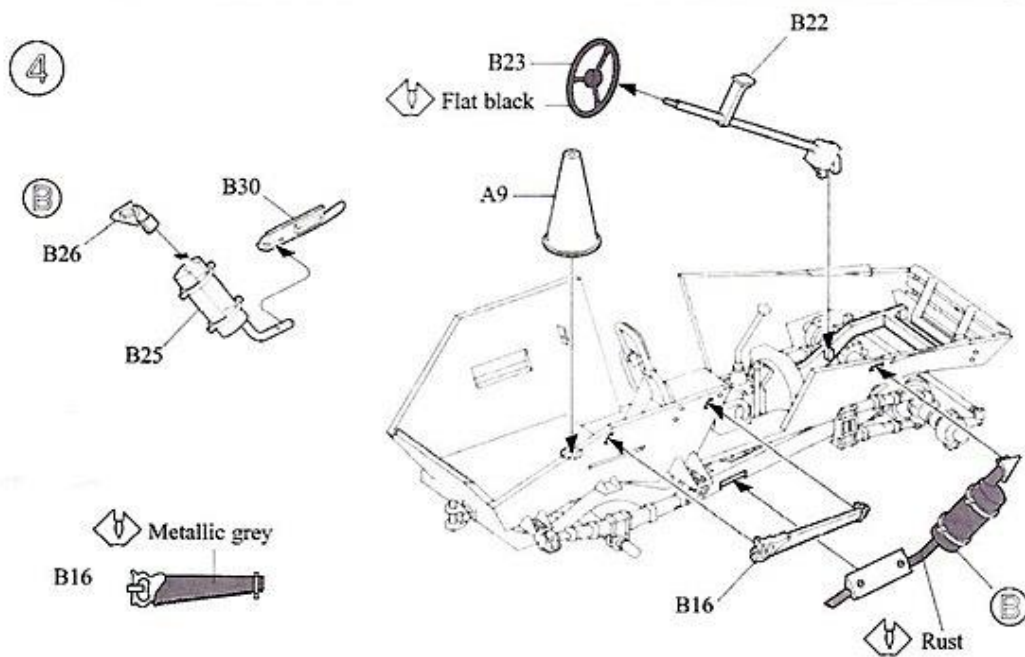
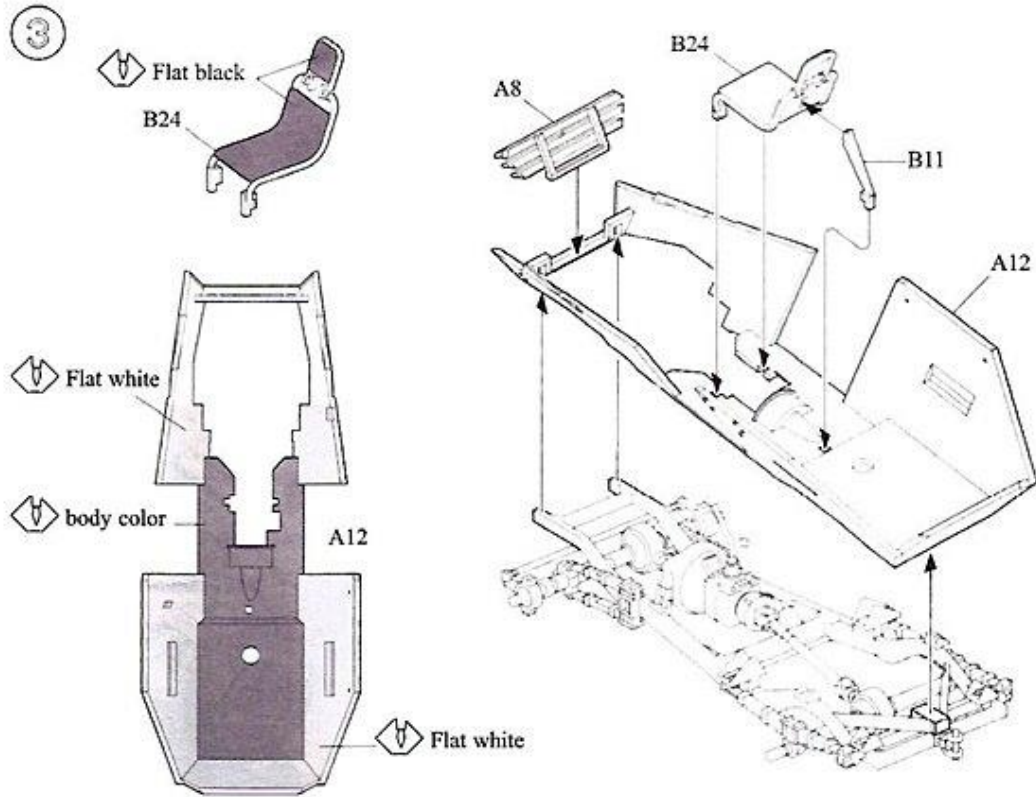

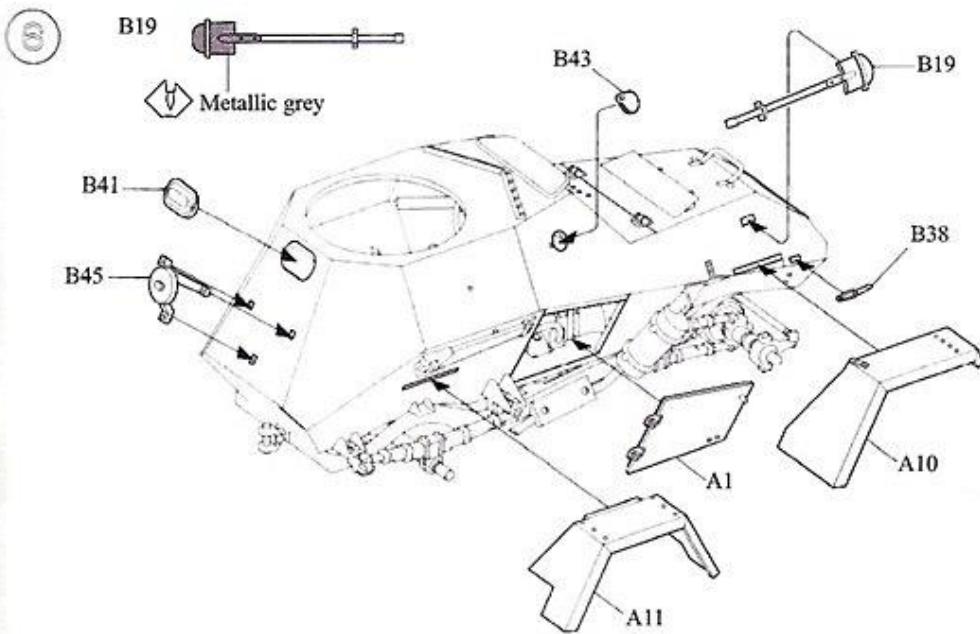
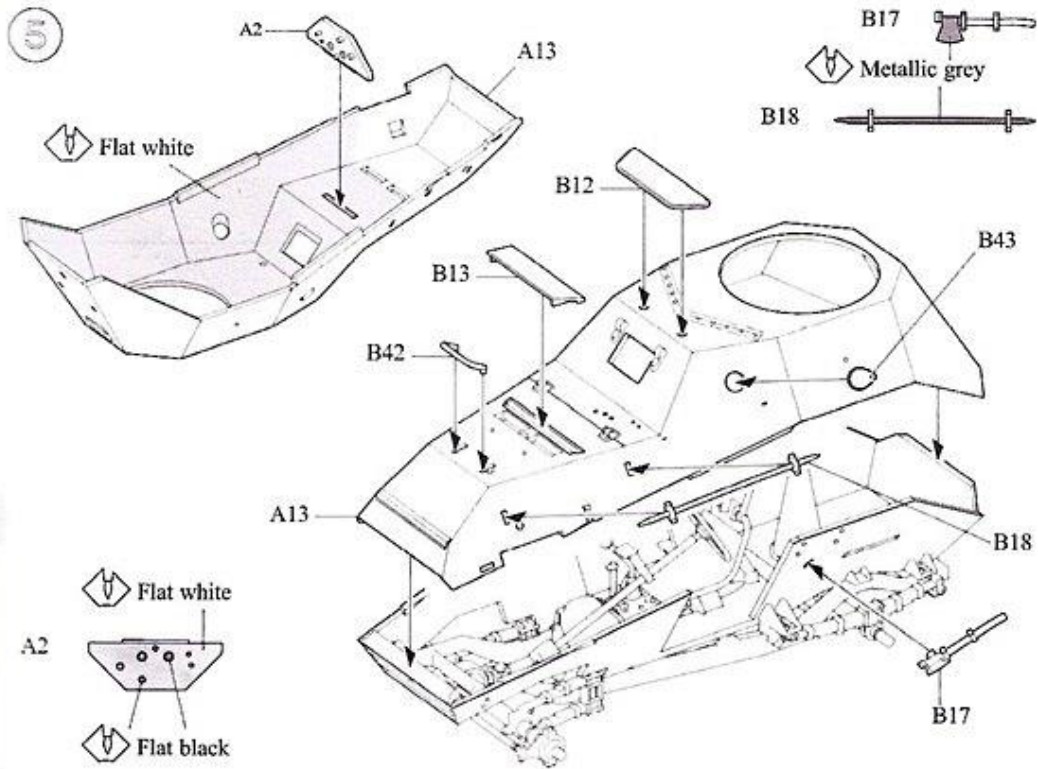

7

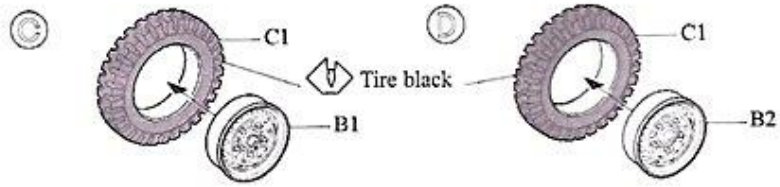

8

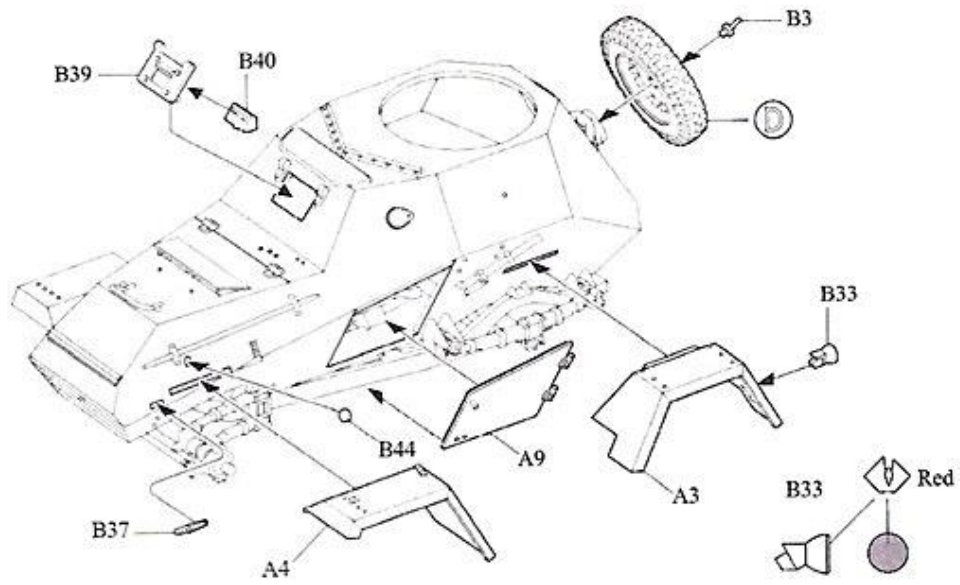

9

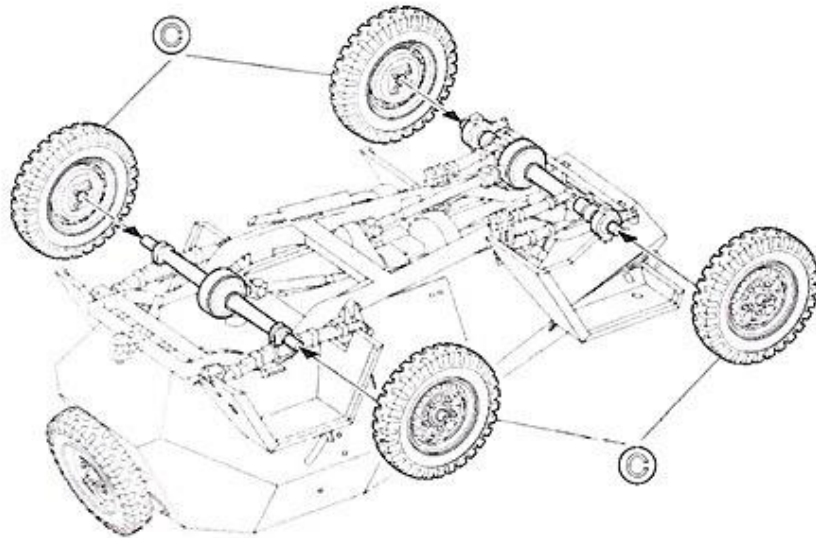

10

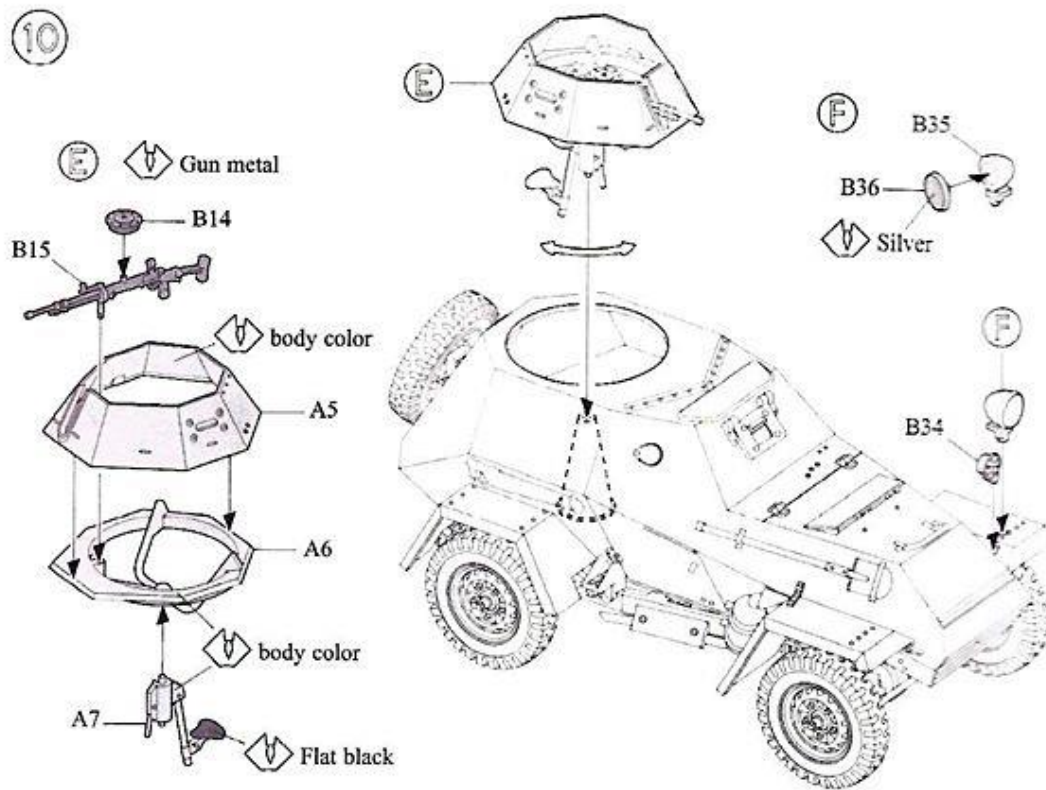

Color scheme



Unidentified armoured unit.
Ukraine, winter 1943~1944.



body color: Russian green
or
Olive drab

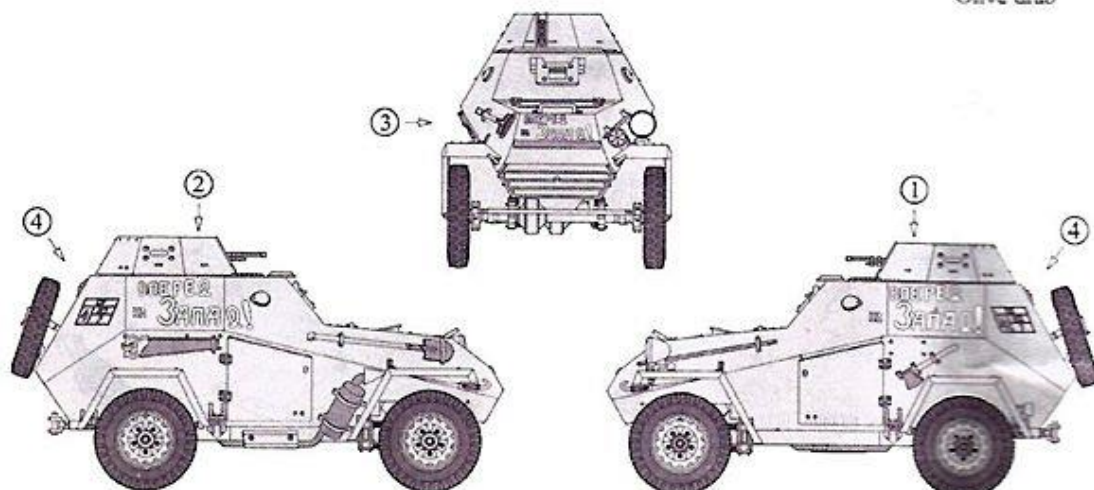

II

13th Guards Mechanised Brigade 4th Guards Mechanised Corps.
Ukraine, August 1944.

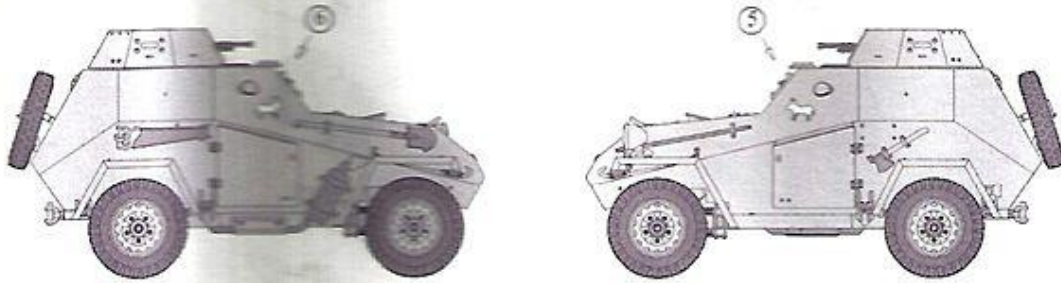

II

The deer silhouette marking near Razdelnaya railway station.
Ukraine, 1944.

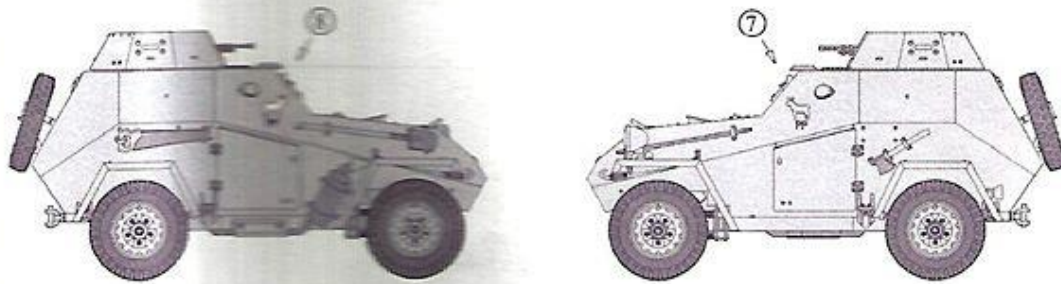

IV

Unidentified unit, from the Ukraine Front.
Germany, April 1945.



V

Czechoslovakia armoured unit.
1st Independent Armoured Brigade.
Prague, May 1945.

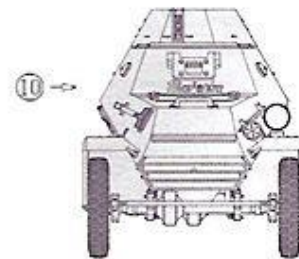



Unidentified unit, from the Ukraine Front.

Germany, April 1945.

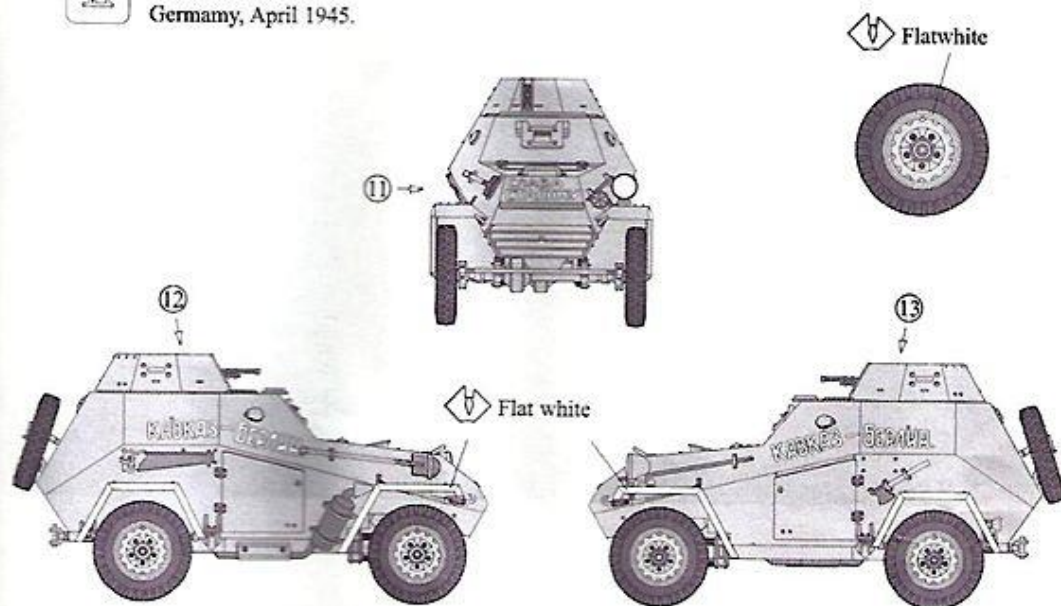

1st Guards Mechanised Corps, from the Ukraine Front.

Vienna, Austria, April 1945.

