

Harrier AV-8A United States Marine Corps (USMC)

Scale 1/32 (but various scales possible for these decals)

HISTORY

The Hawker Siddeley Harrier was developed in the 1960s as the first operational ground attack and reconnaissance aircraft with vertical/short take-off and landing (V/STOL) capabilities. Development started with the Kestrel prototype aircraft and this evolved into the Harrier GR.1 first flown end 1967. The design had a single special Pegasus turbofan engine mounted in the fuselage and four vectoring nozzles. For control at low speed in hovering flight, several small reaction nozzles are also fitted, in the nose, tail and wingtips. The Harrier was first ordered for the British Royal Air Force, with the GR.1.

A version of the GR.1 was exported to the United States as the AV-8A, for use by the US Marine Corps (USMC) in the 1970s. The AV-8A jets were manufactured in the UK by Hawker Siddeley but got fitted by McDonnell Douglas with American systems, another Stencel S3 ejection seat and Sidewinder capability.

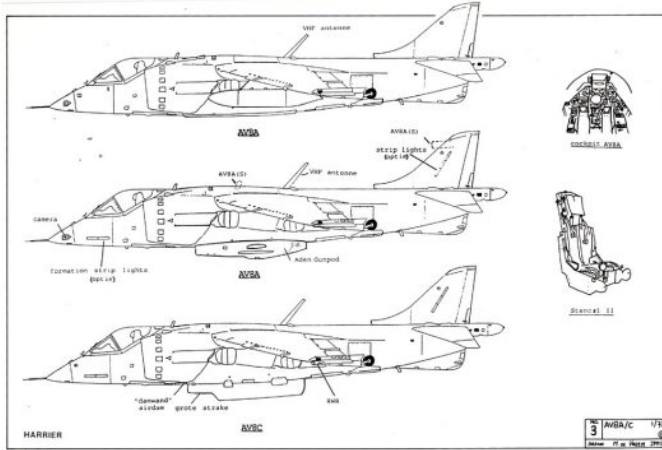

USMC AV-8A

The AV-8A entered service with the USMC in 1971. Some 102 AV-8A and 8 TAV-8A trainers were acquired. The jets could also operate from amphibious assault ships but were mostly flown from U.S. land bases.

Some AV-8A were upgraded from 1979 to AV-8C standard with new systems, 2 large strakes and "air dam" for better lift. Radar warning detection and chaff fairings were also installed.

The AV-8A fleet was later replaced by the quite changed AV-8B Harrier II series.

MODEL KITS

In 1/32 scale only Revell USA released a Harrier way back in 1972 as kit #H194 and in 1982 as kit #4718. The kit has some shapes resembling the Kestrel development aircraft.

Making a AV-8C is well do'able with some scratch building.

[Note: no 1/32 TAV-8A(s) kit is available and it would require conversion with a "Tigger" vacuform set].

>>>

>>> The modeller can modify a bit the 1/32 Revell Harrier kit for a better looking AV-8A with mainly these changes:

- The fairing shape in front of the forward nozzle can be made a bit bulkier and "less pointy" with card and putty.
- The number of blow in doors at the bulkier fairing should be 9 (and not 8 as per Kestrel). Also add a small NACA air intake.
- Change some upper engine panel exhaust grills.
- If using the underwing fuel tanks, remove their tail fins.
- Improve the various details like the cockpit, ejection seat and smaller airframe bits.

A full modelling report showing the improvement and with further tips can be found at my website at:

<https://aircraftinplastic.com/models/harrier-32/harrier-32-1.html>

<https://aircraftinplastic.com/models/harrier-32/harrier-32-2.html>

My YOUTUBE film:

<https://youtu.be/1FEIfk7tkbI>

DECAL APPLICATION

The decal sheet has ONE continuous print film, so each decal needs to be cut out with fine scissors. No other prior decal preparation is needed.

Note that a decal that contains a white section is often split in two sections. To apply the full decal marking, first set the white decal section at correct position and on top of that the coloured section. On the decals sheet you will often see an "arrow" to indicate this way of application (on white surfaces, the white section is optional).

Each cut out decal can be applied as usual after soaking it a short while in water. Decals are EXTREMELY THIN, so slide off from the wet backing sheet on a horizontally held GLOSSY model surface. Do not use tweezers! They will fold doubled!

After all decals have been applied, finish the model with your preferred final gloss, matt or semi-matt varnish coats. This will also protect all the decals.

REFERENCES:

- AV-8 Harrier, Detail & Scale, Part 1 USMC, TAB Books.
- Harrier in action, no. 58, Squadron Signal publications.
- IPMS U.K. "SIG Asian Air Arms newsletter #33" about Thai Harriers.

On internet it is very easy to find photos by searching...

AV-8A + USMC

COLOUR SCHEMES AV-8A USMC

The USMC AV-8A/C standard scheme is an upper camouflage pattern of Federal Standard FS36173 gray and FS34079 green and FS16440 gull gray on lower surfaces.

Early aircraft had no low visibility lights panels. When setting the low visibility lights, first add the white underlying decals and the yellow ones on top.

See the drawings for the port and starboard patterns and the top and lower surfaces.

The sheets has several "black codes" so other jets Bur.no numbers can also be made.

Note the large AV-8A sprite antenna on the spine.

The AV-8 has standard smaller stencils/ service maintenance markings, apply from the decals sheet of as per kit. (see separate drawing).

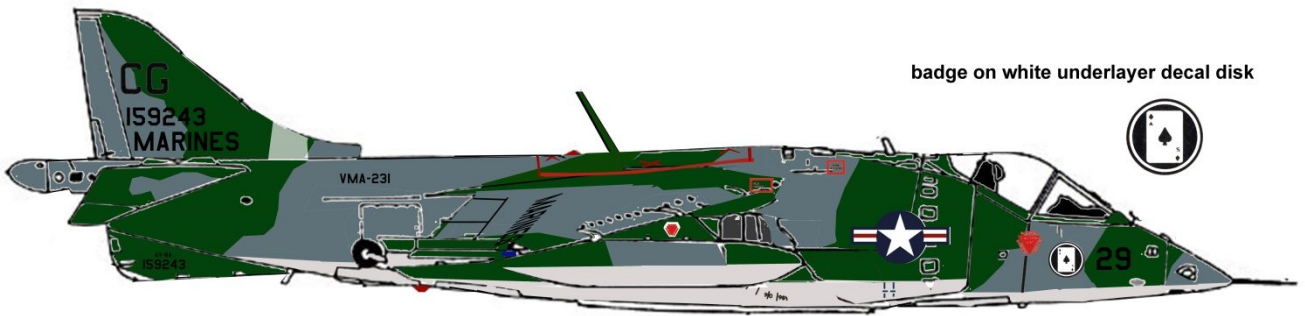

[A] USMC AV-8A, US Bur.no 159243, (msn 712152), VMA-231, coded CG. Nose number "29".

Marine Attack Squadron VMA-231 was re-activated on May 15, 1973, and the Marine Corps' oldest squadron became the Corps' newest, flying the Corps' newest aircraft, the Hawker Siddeley AV-8A Harrier.

Large "Ace of Spades" badge on nose, set white underlying disk decal first.

From October 1976 VMA-231 was deployed to the Mediterranean aboard USS Franklin D. Roosevelt (CV-42) with Carrier Air Wing 19. In 1977 VMA-231 was named V/STOL squadron of the Year.

The large access hatch in the upper fuselage spine has red outlines and red crosses.

The jet was later brought to AV-8C standard. To AMARC September 1986.

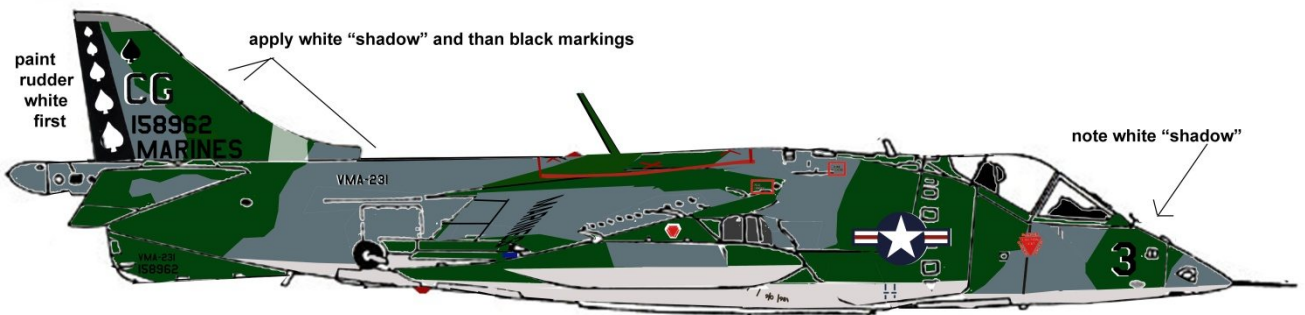

[B] USMC AV-8A, US Bur.no 158962, (msn 712123), VMA-231, coded CG. Nose number "3".

With special painted rudder. Paint the rudder white before setting the "Ace of spades" decal.

Codes have a white outline shadow which are provided with base white decals; set these first and on top the black decals.

This jet on board of USS Guam visited also the UK Southampton port in October 1974 with VMA-513.

The large access hatch in the upper fuselage spine has red outlines and red crosses.

The jet was later brought to AV-8C standard.

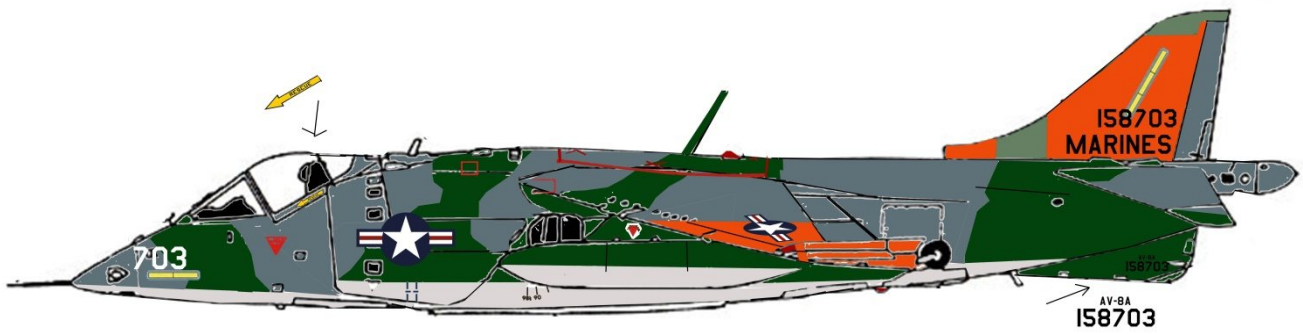

[C] USMC AV-8A, US Bur.no 158703. (msn 712100). Nose number "703".

This jet was used for tests and was based at Patuxent River NAS/ Trapnell Field in Maryland (1978). Besides the camouflage scheme, it had high-visibility bright red-orange panels on lower and upper wing tips and tail. These upper and lower panels are "mirrored"/ symmetrical.

The large access hatch in the upper fuselage spine has red outlines and red crosses.

Seen with the low visibility lights panels.

The jet was later deployed to USS Tarawa (1981) in probably a standard scheme.

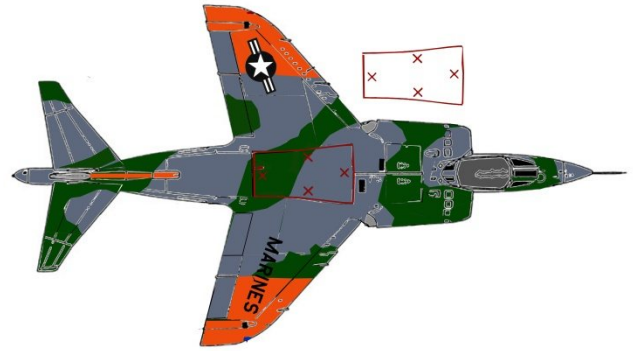



[D] USMC TAV-8A trainer, US Bur.no 159382, (msn 212022/8). Operated by VMAT-203 based at NAS Cherry Point, North Carolina. Code KD, nose number "04". Several white codes and markings.

The large access hatch in the upper fuselage spine has red outlines and red crosses.

Paint the rudder white and than set the red-(white)-blue stripes.

Marine Attack Training Squadron VMAT-203, known as the Hawks, was based at Cherry Point and fell under the command of Marine Aircraft Group 14 and the 2nd Marine Aircraft Wing. Their former radio call sign was "Mars".

This TAV-8A went to AMARC October 1987 and later to Pima Air and Space museum, Arizona.

Note:

no 1/32 scale TAV-8A(s) kit is available and it would require conversion of an AV-8A kit to TAV-8 trainer with a "Tigger" vacuform set or through scratch building.

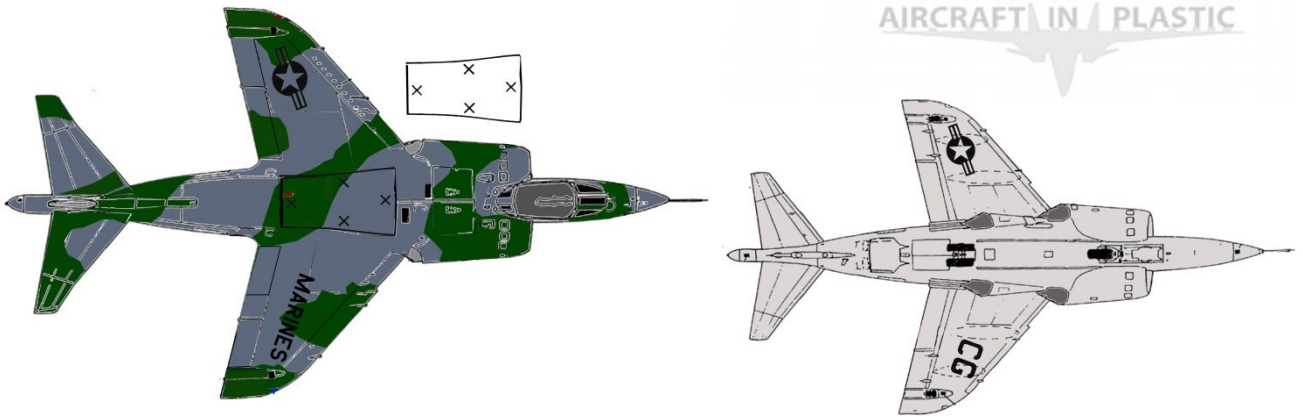

AV-8A USMC typical upper and lower camouflage views

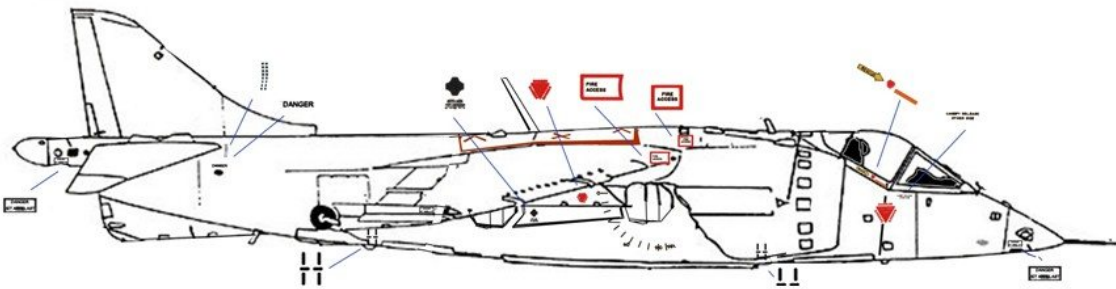
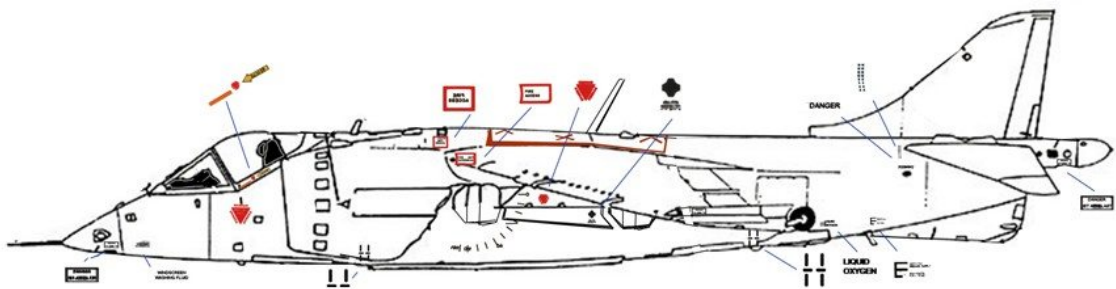

TYPICAL STENCILS AV-8A

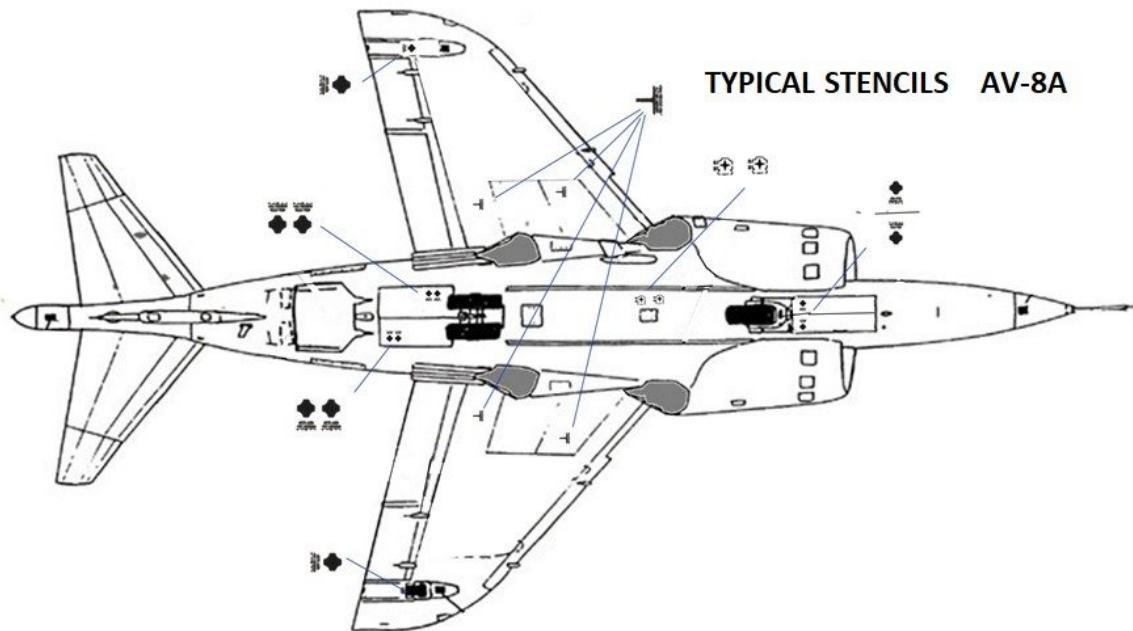

Please visit website: www.aircraftinplastic.com