

1/48 Armstrong-Whitworth F.K.8

Mid.production version



The Armstrong-Whitworth F.K.8 was a British WW1 two seater reconnaissance and bomber aircraft, designed by Dutch designer Frederick Koolhoven and intended as a replacement for the Royal Aircraft Factory's BE.2c and Armstrong-Whitworth's earlier F.K. 3.

Around 1700 F.K.8 aircraft were produced, and it served on the Western Front and other theatres where it was useful for reconnaissance, artillery spotting, ground attack and also bombing duties.

Despite its popularity with the men who flew it, the F.K.8 was unfairly overshadowed by the better known R.E.8 and today is one of the lesser known British two seaters of WW1.

Known affectionately to airmen as the "Big Ack", the F.K. 8 type first flew in 1916 and was developed in various stages. The "Mid Production version", the subject of this kit, featured a visually more streamlined nose than the early version, and was powered by a 160 hp Beardmore engine. It retained the oleo undercarriage of the Early version. The aircraft went through various modifications during its lifespan including a later change to a conventional Vee shaped undercarriage and re-designed smaller radiators on both sides of the fuselage.

Most production F.K.8s had various in-service modifications to the wings, gunner's seat and the exhaust system.

The first F.K. 8's went to France in January 1917 equipping 35 Squadron RFC. It served with five squadrons on the Western Front and also saw service in the Middle East as well as Home Defence duties in Britain. The last squadron to use the F.K.8 was 150 Squadron which was disbanded in 1919. Two of the 19 Victoria Crosses awarded to WW1 airmen were won by F.K. 8 pilots, one flying a Mid Production version and the other a Late version in combats in 1918.

At the war's end eight F.K.8 aircraft were registered for civil use, with two of them used in Australia as part of the early fleet of the Queensland and Northern Territory Aerial Services which later became the airline Qantas.

Copper State Models SIA
Lubanas 78, LV-1073,
Riga, Latvia



Visit our website
www.copperstatemodels.com

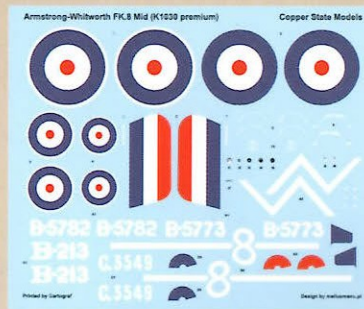
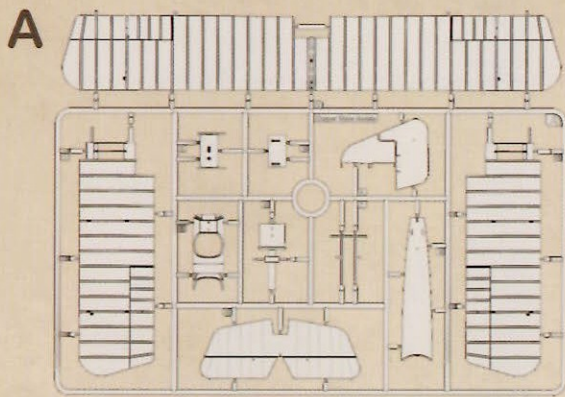

Decals

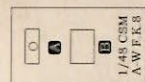
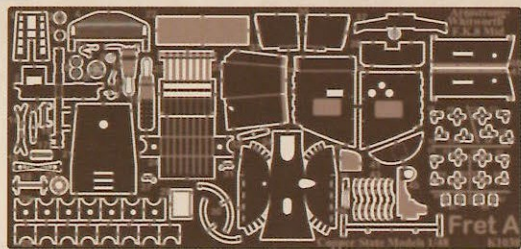
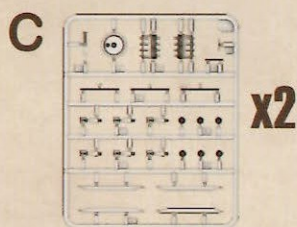
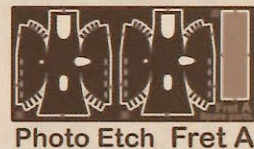
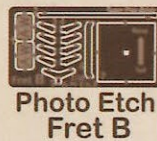
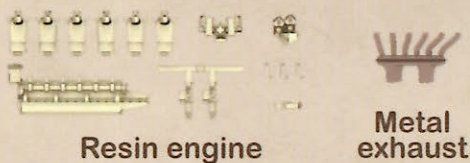
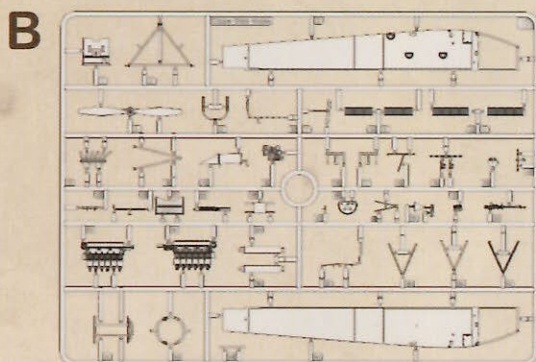

Acetate windscreens

No	Colours
1	Copper
2	Brass
3	Semi Gloss Black
4	Aluminum
5	Gun Metal
6	White
7	Light Wood
8	Leather
9	PC10
10	Clear Doped Linen
11	Battleship Grey
12	Dark wood
13	White
14	Rubber
15	Grey

Symbols Reference

- Colour
- No Glue
- Use cyanoacrylate
- Bend
- Other side
- Apply Decal
- Cut/Remove
- Attention
- Subassembly
- Option
- Drill
- Marking options
- Photo Etch Part

I Cockpit

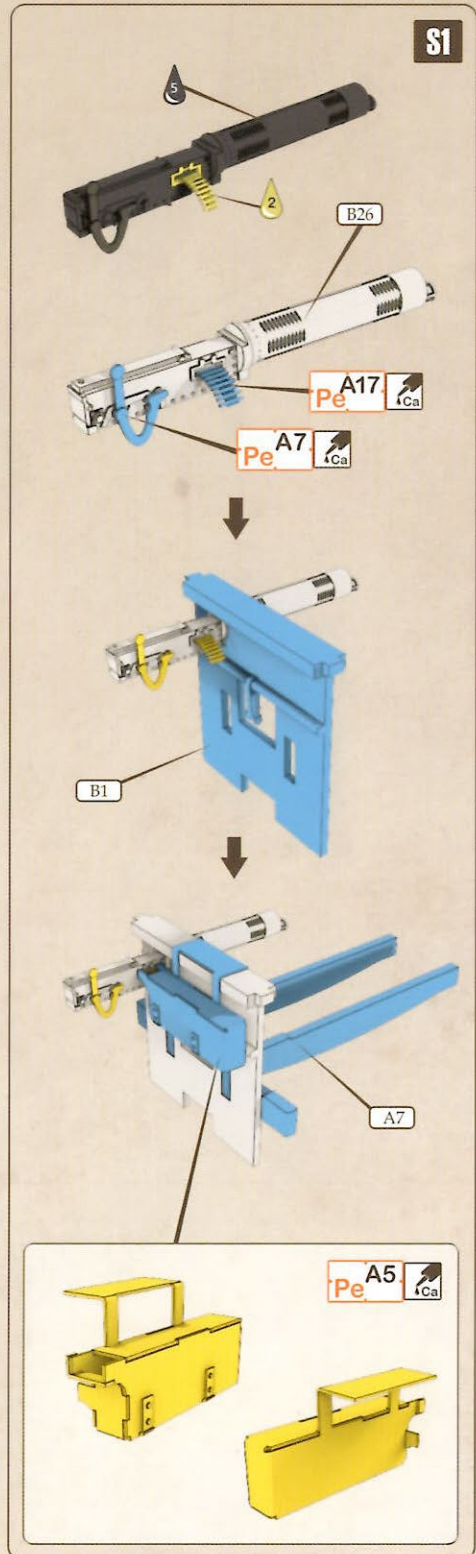
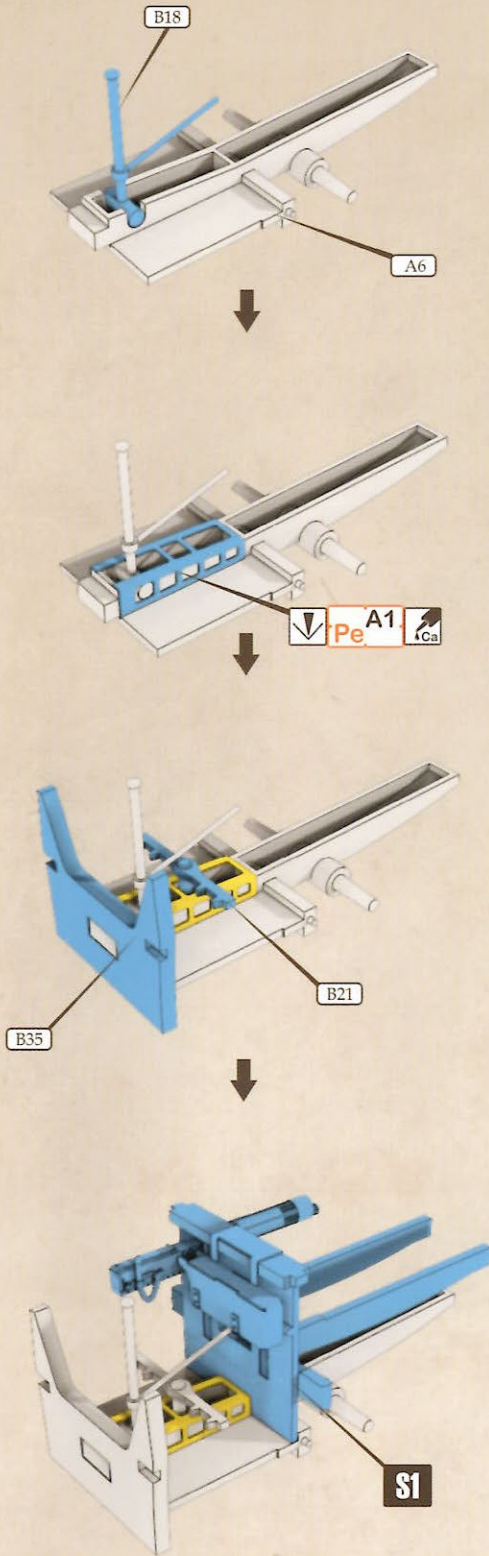

II Fuselage and cockpit

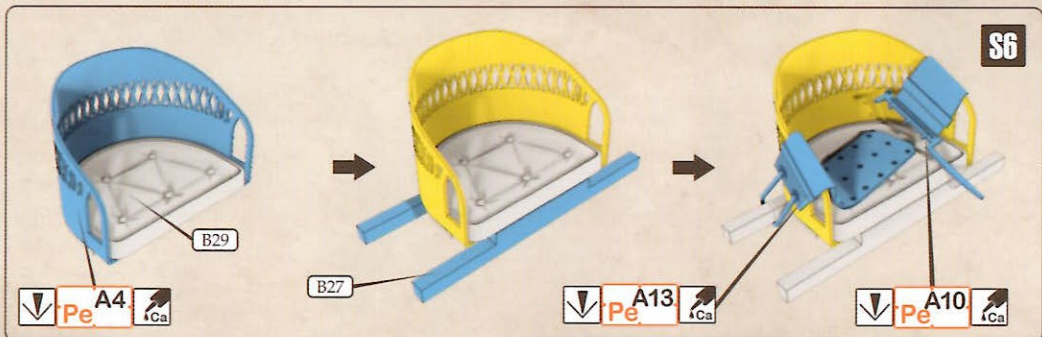
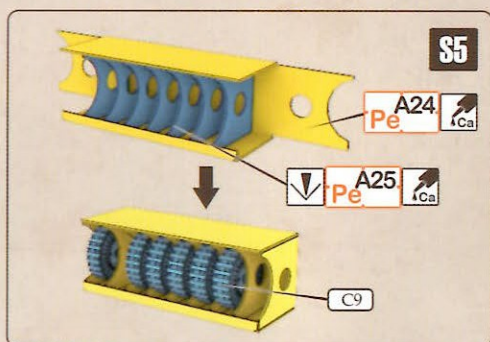
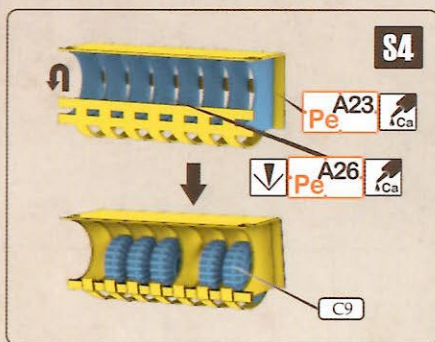
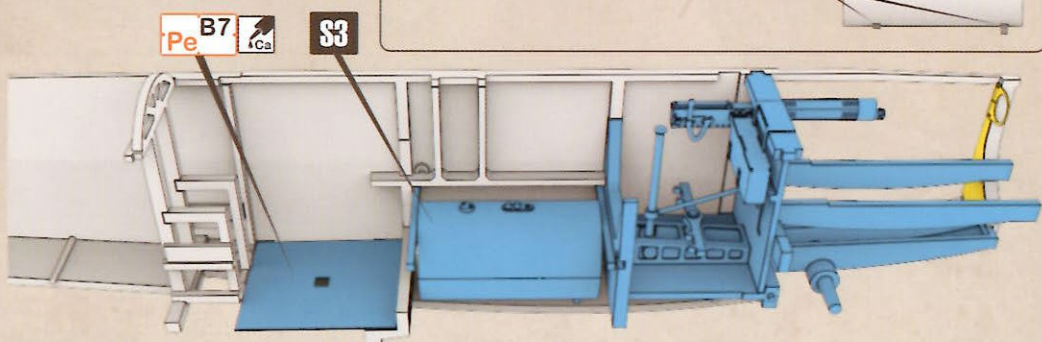
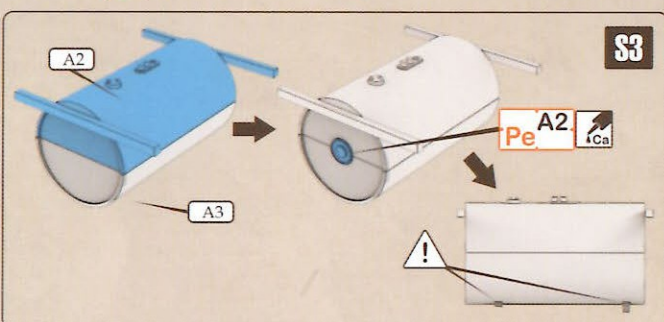
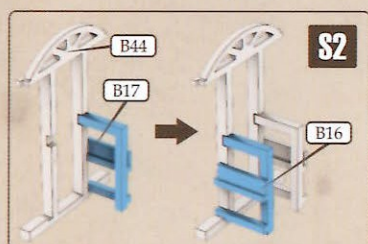
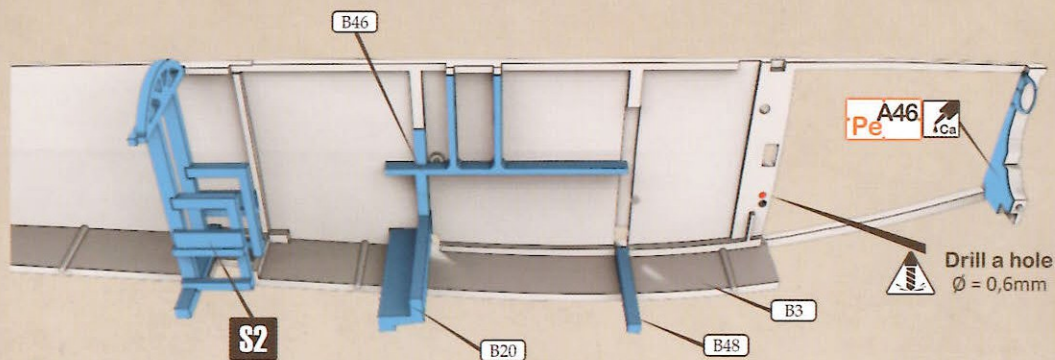

II Fuselage and cockpit

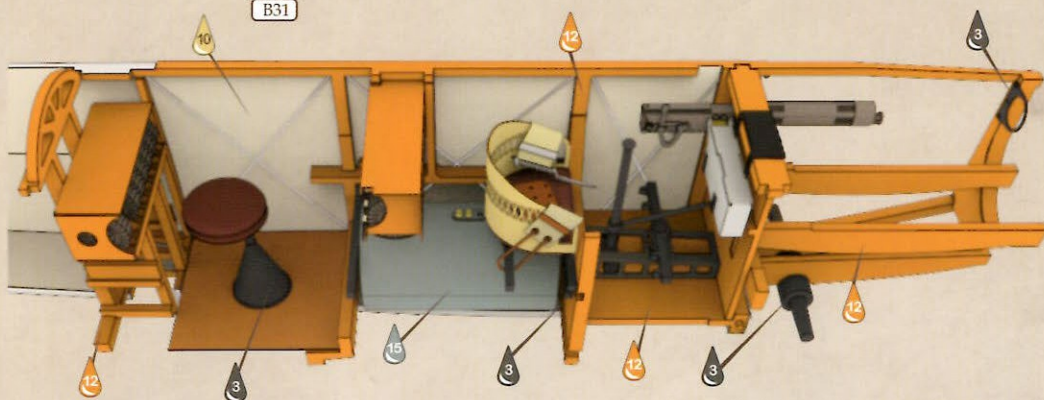
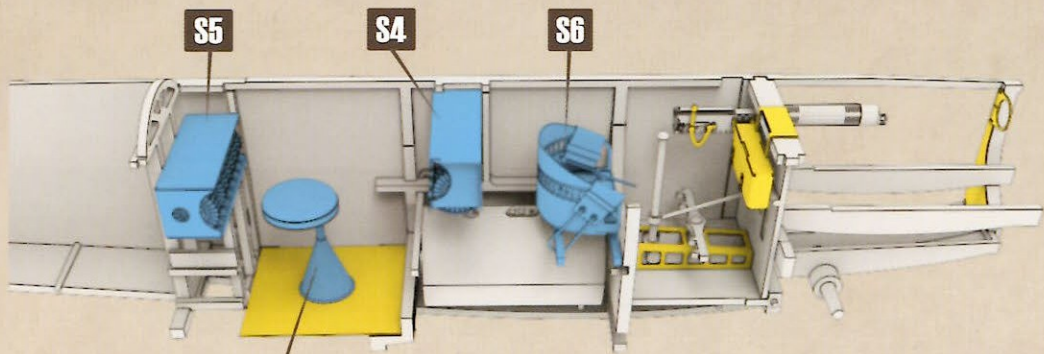

Rigging
 $\varnothing = 0,1\text{mm}$

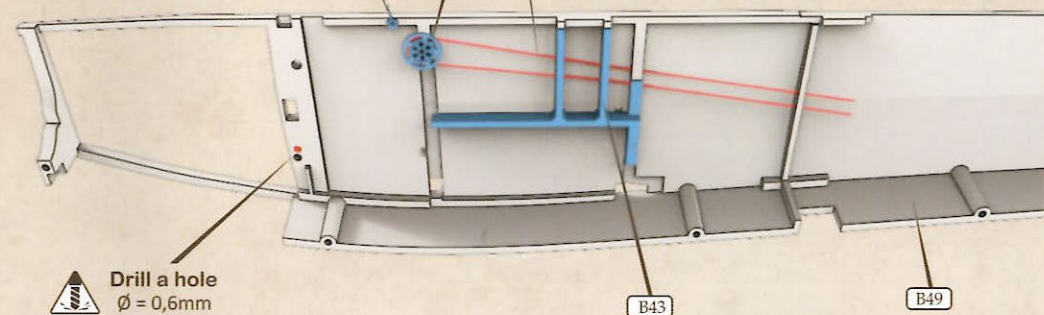
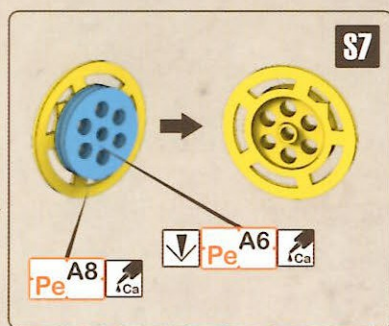

Drill a hole
 $\varnothing = 0,6\text{mm}$

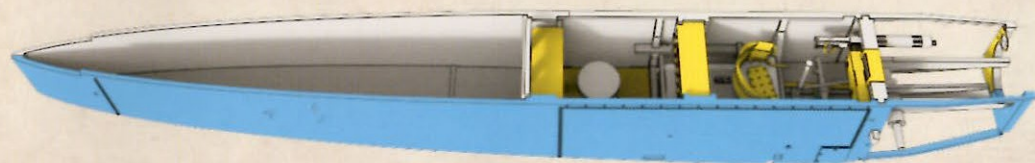

Fuselage and cockpit

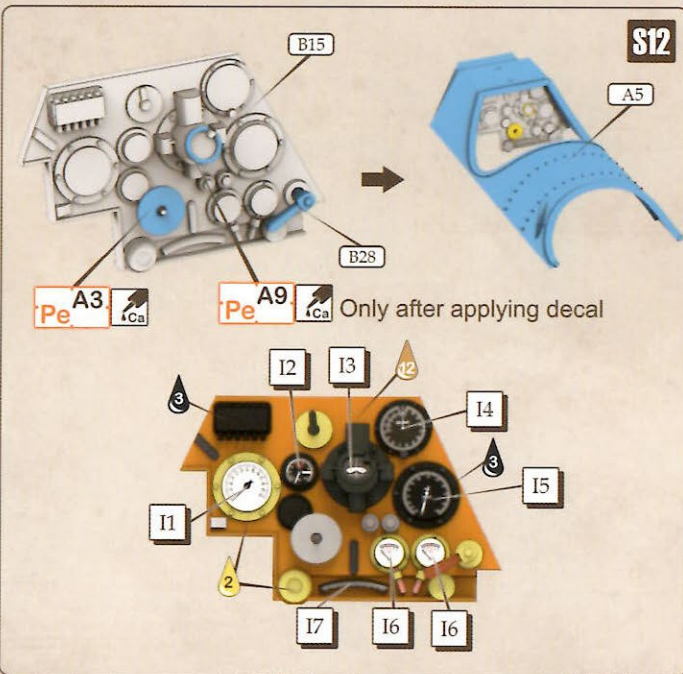
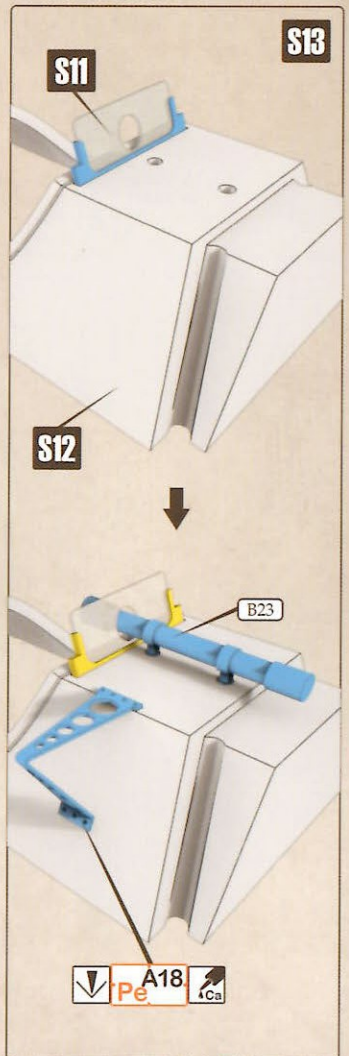
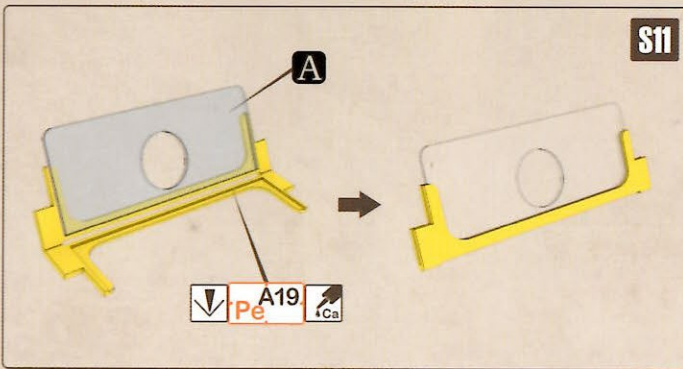
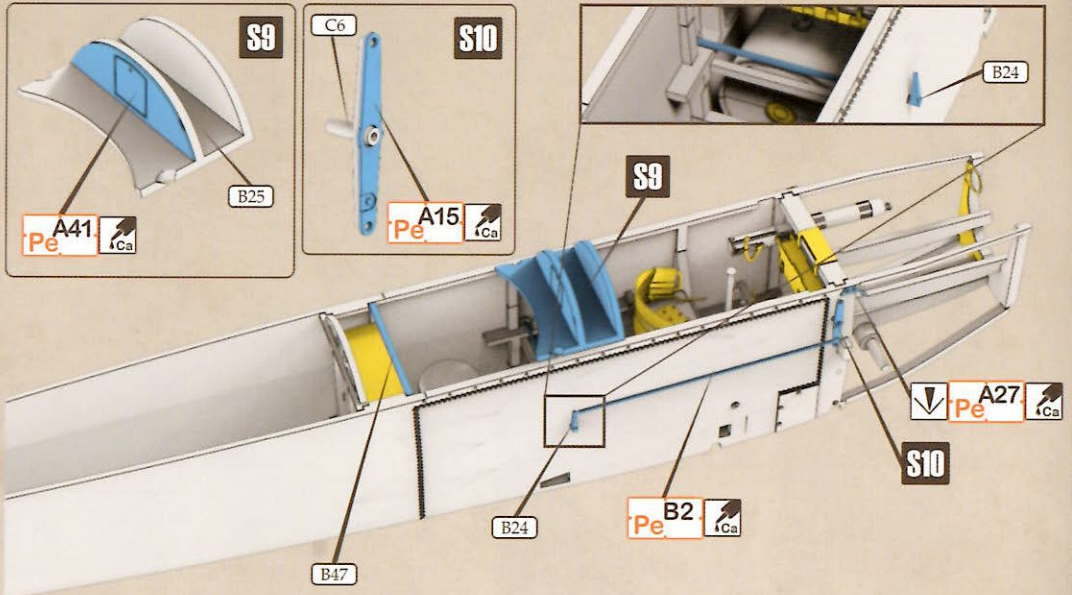

III Fuselage

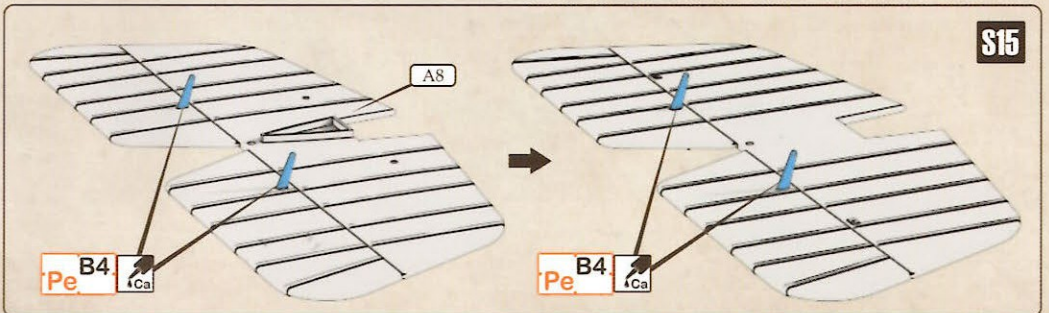
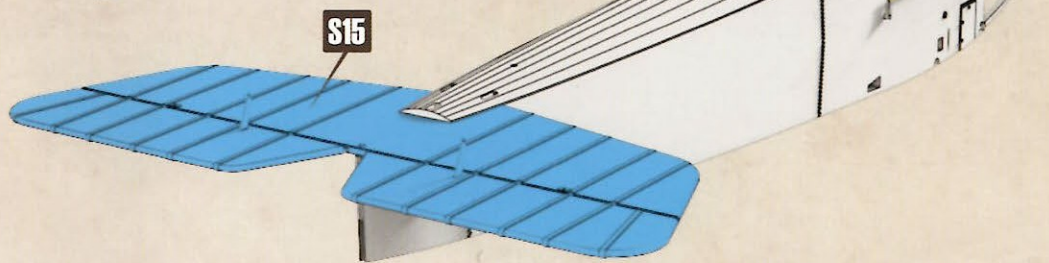
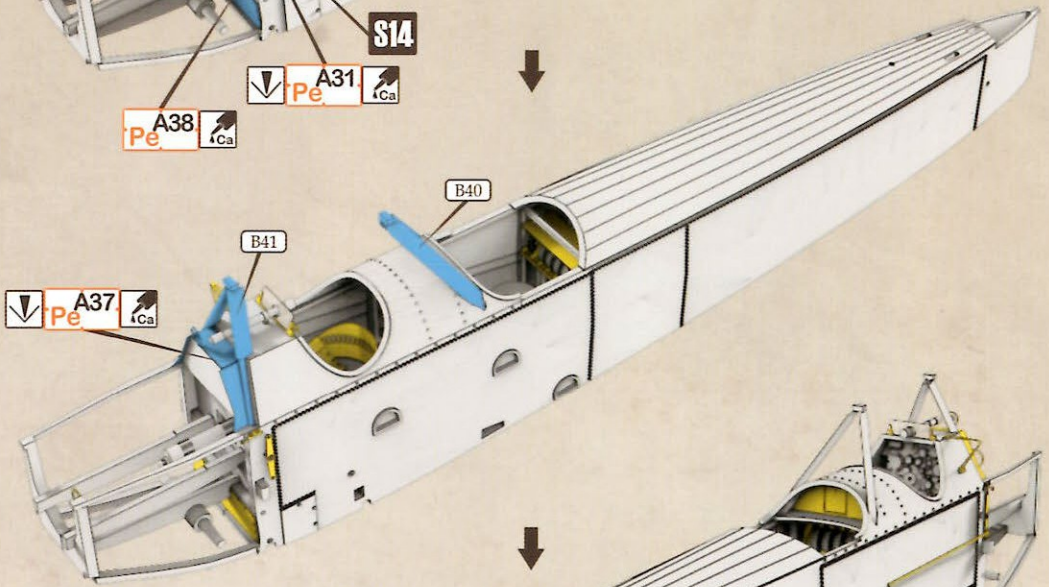
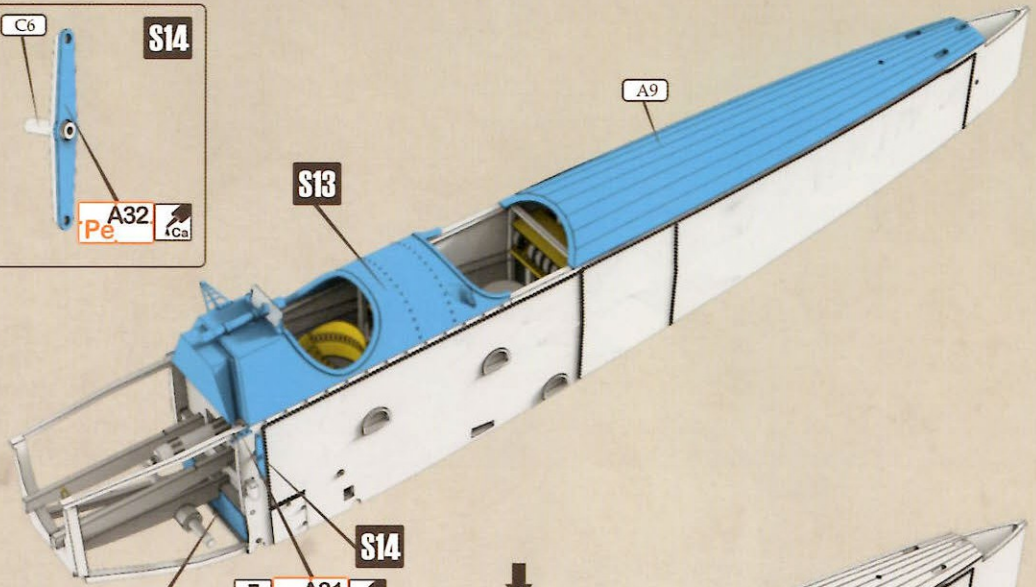

IV Lower wing and rudder

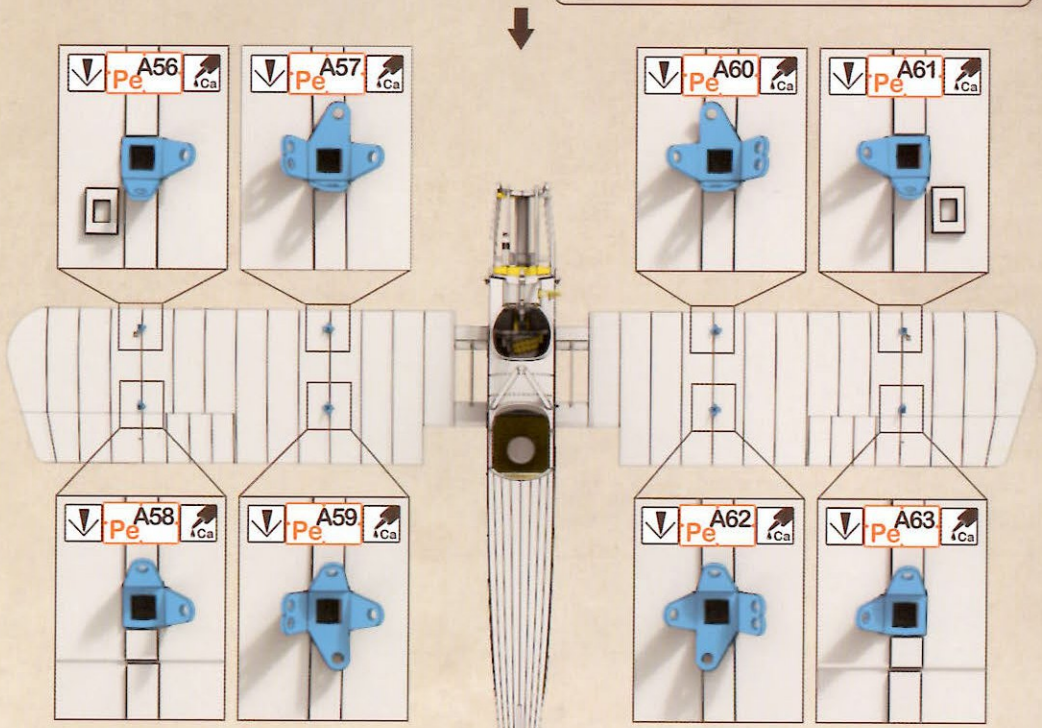
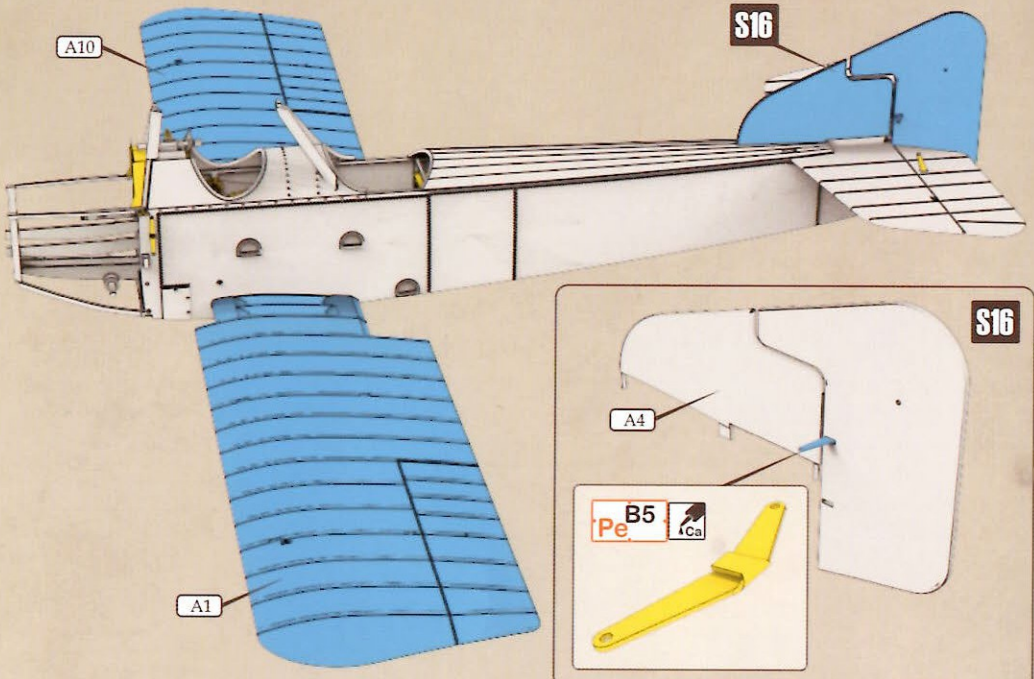

Lower wing aileron horn

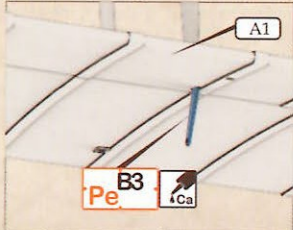

Lower wing aileron horn



V Struts and top wing

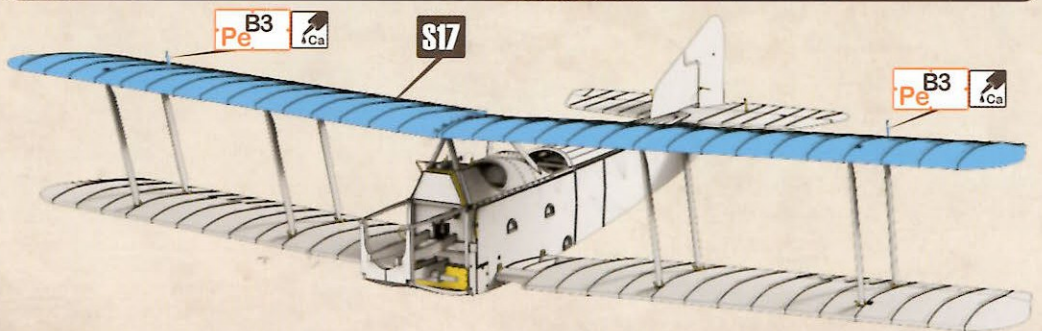
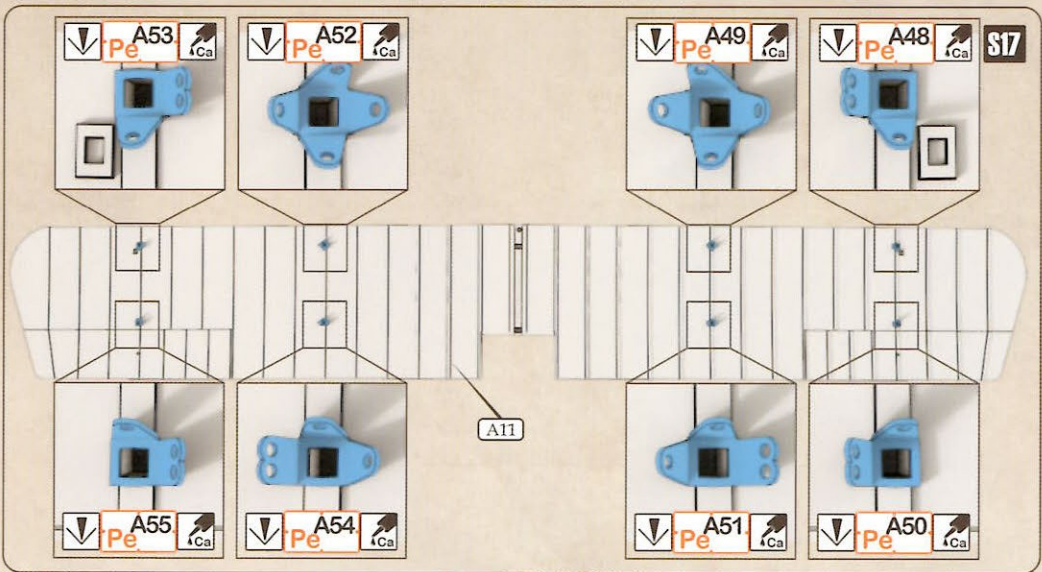
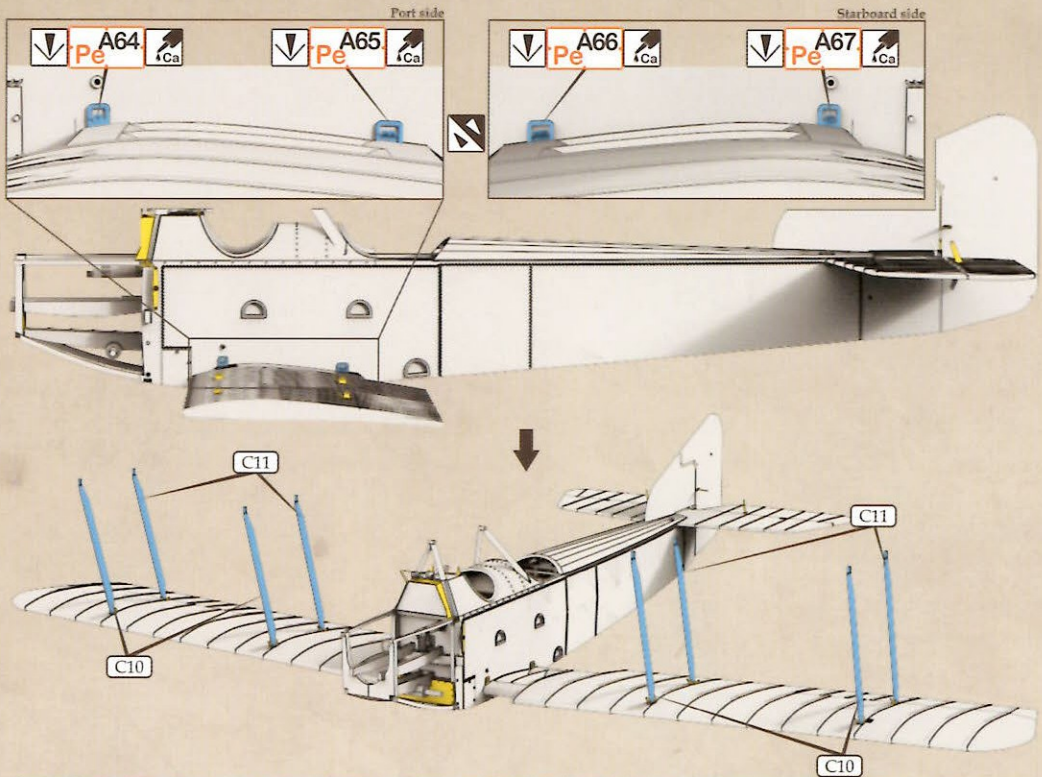

VI Engine

Plastic set engine

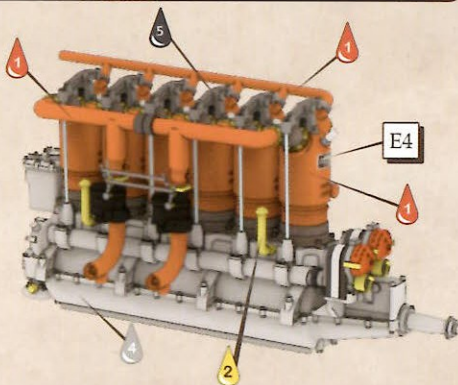
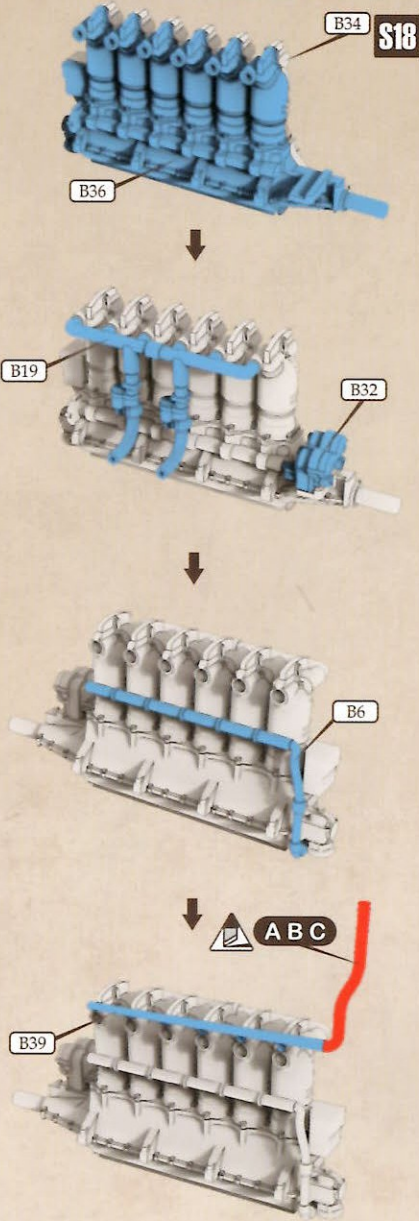

Resin premium set engine

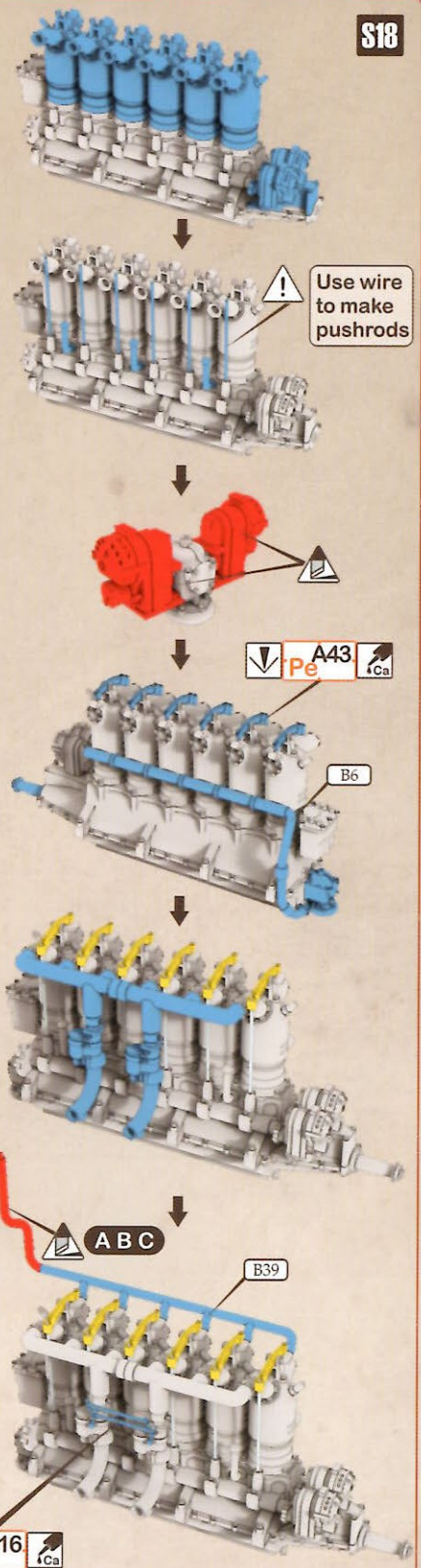

VI Engine compartment

Engine compartment rigging

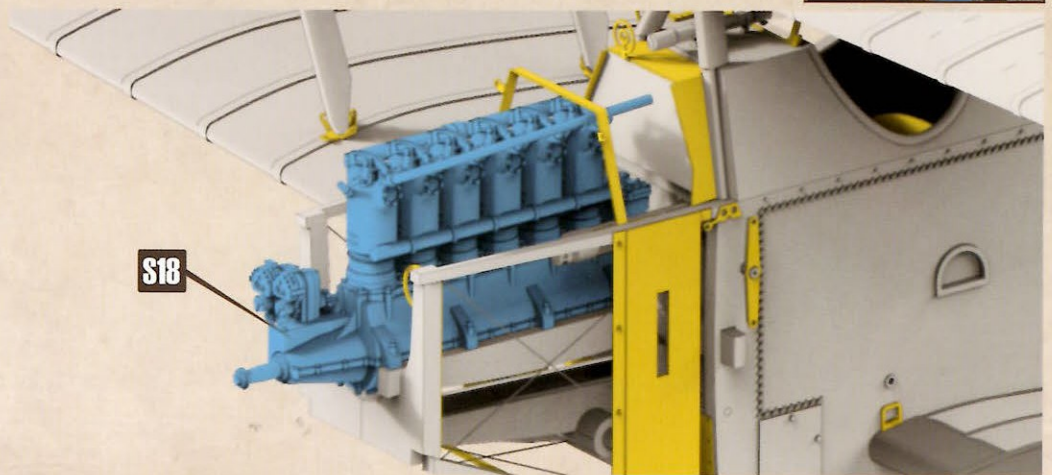
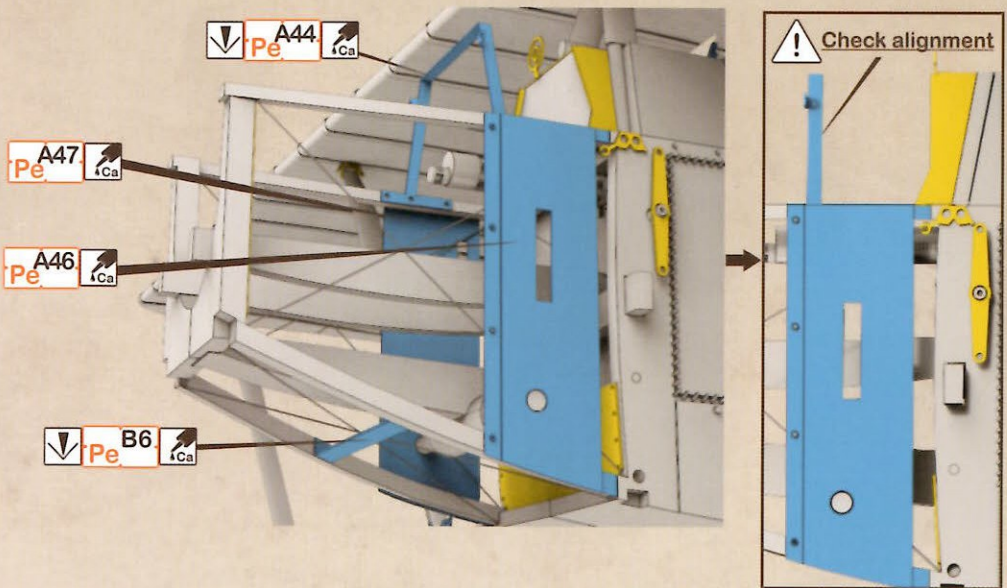
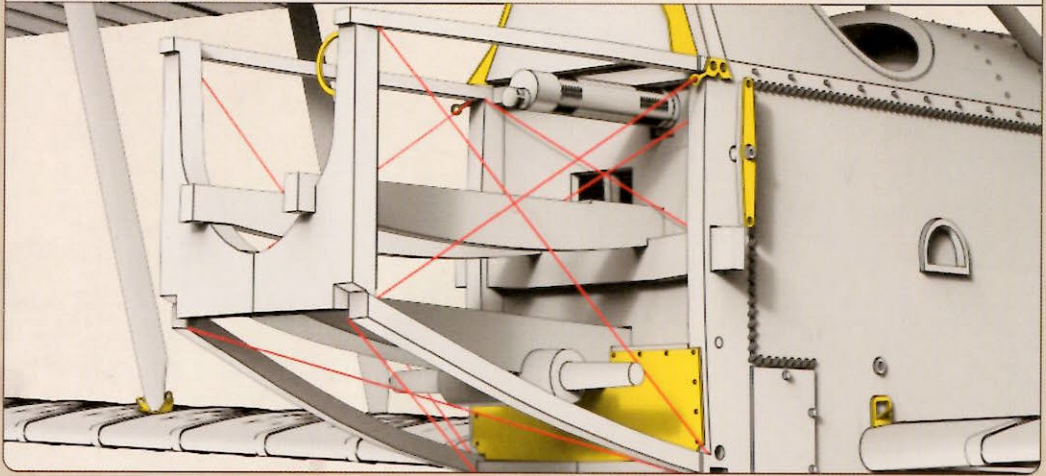

VII Undercarriage and other

S19

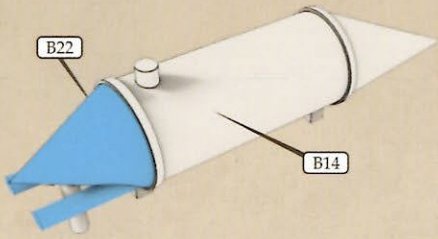

S19

Pe A35 Ca

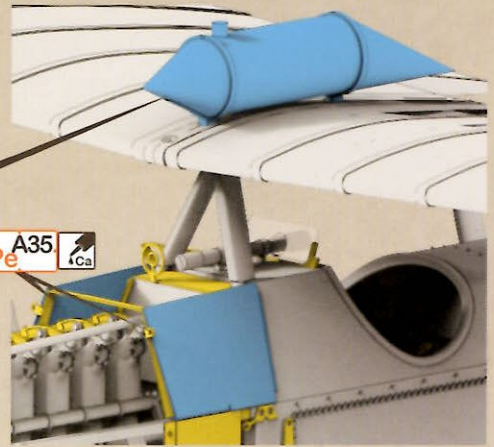

S20

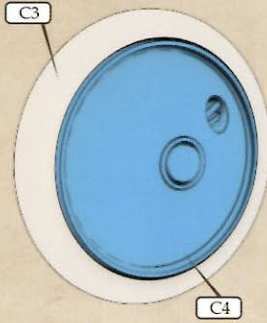

x2

Pe A22 Ca

Pe A21 Ca

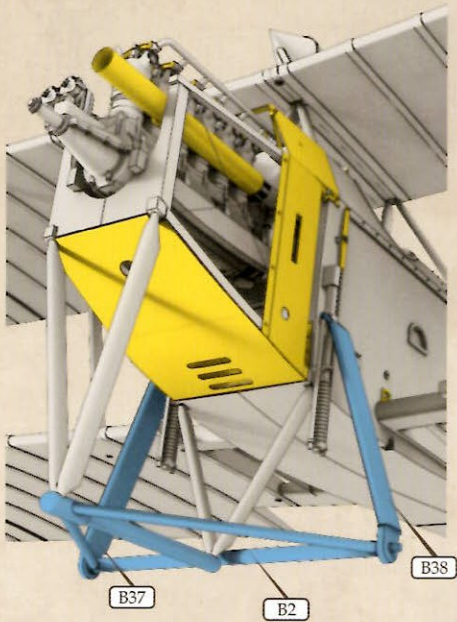
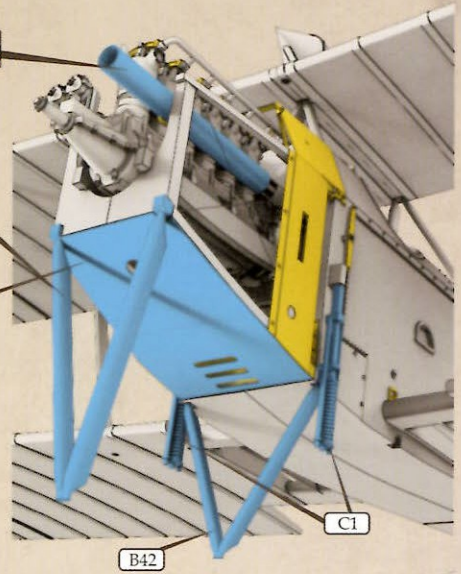

VIII Cowling, radiators and exhaust

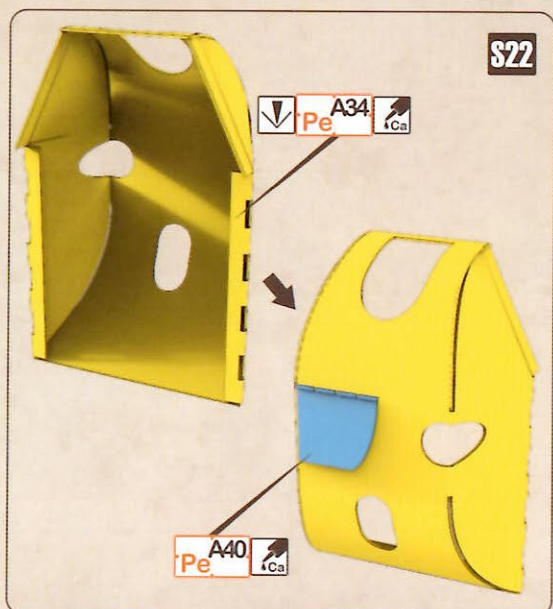
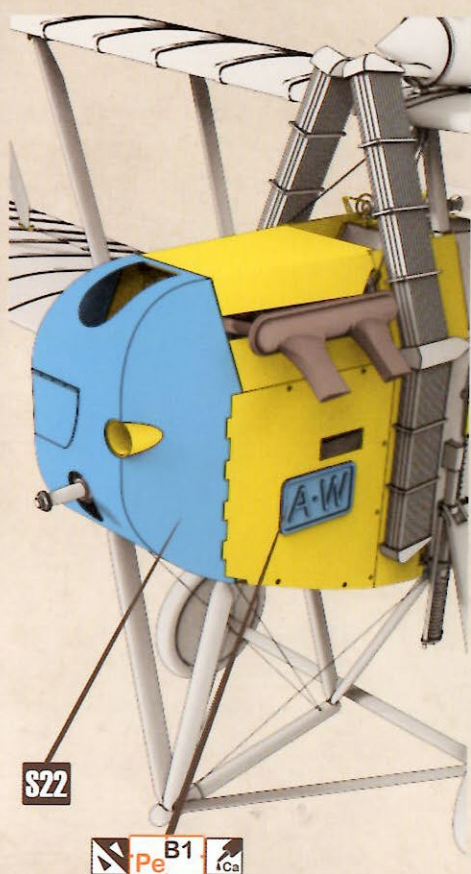
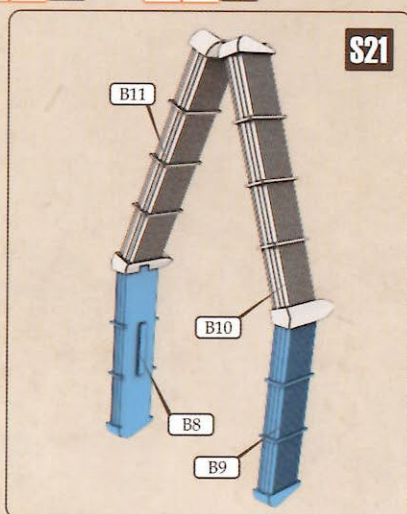
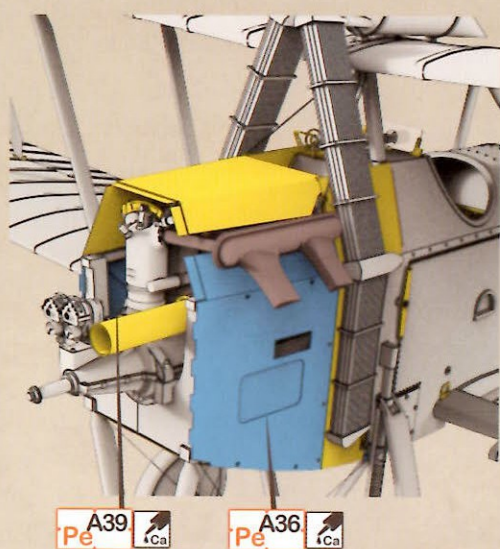
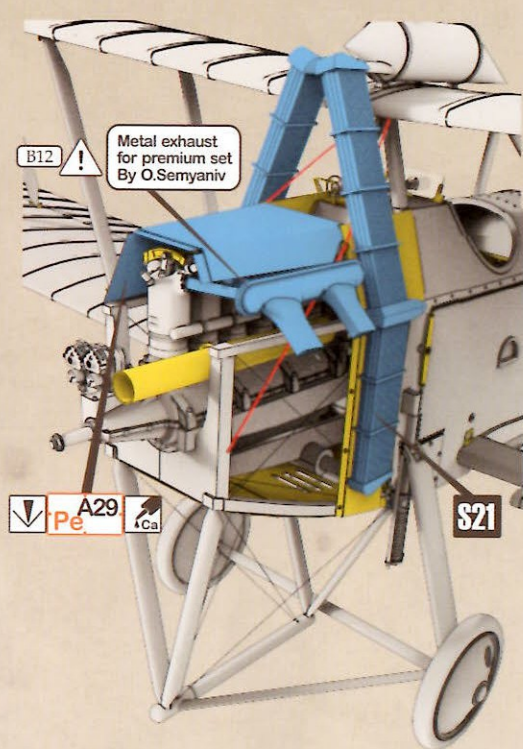

IX Lewis MG and tail skid

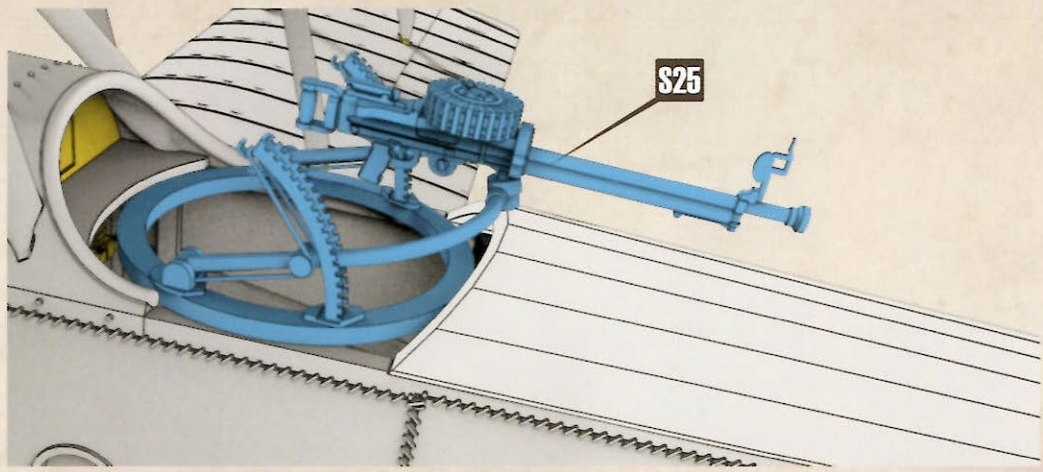
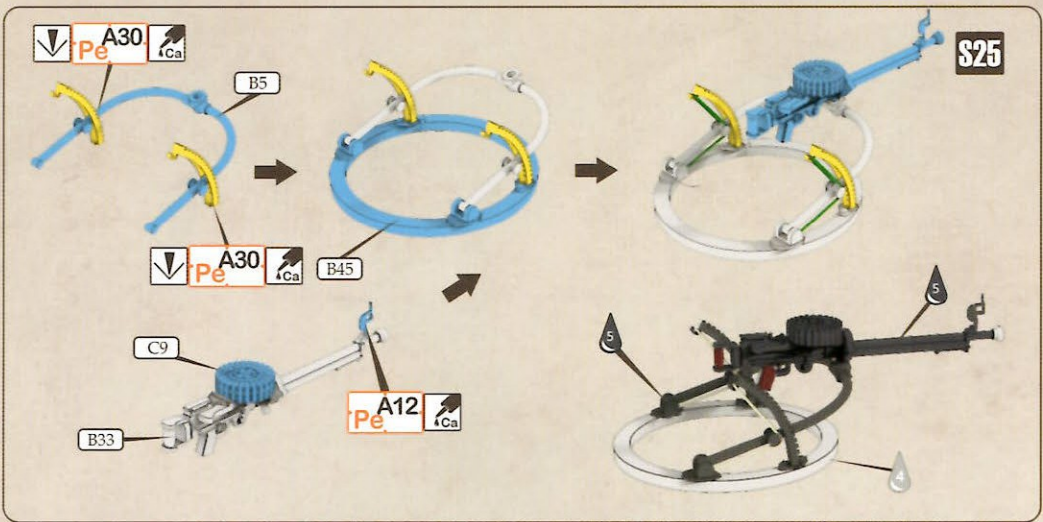
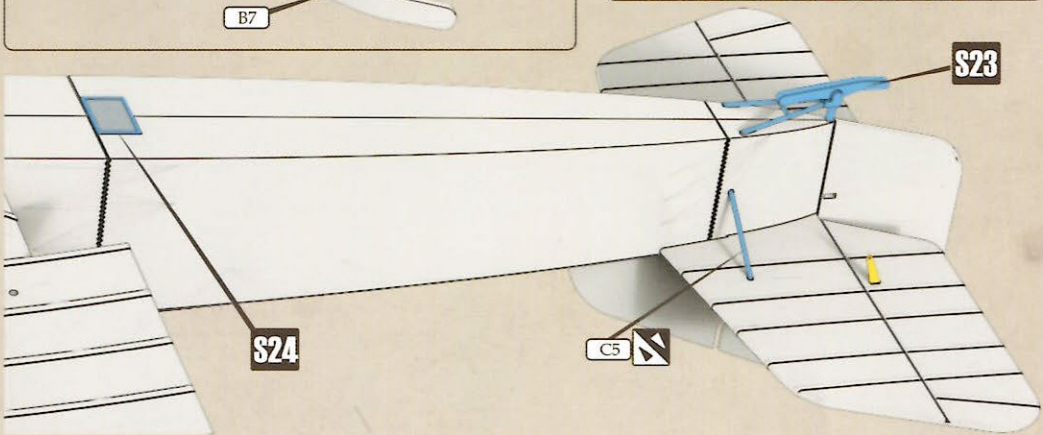
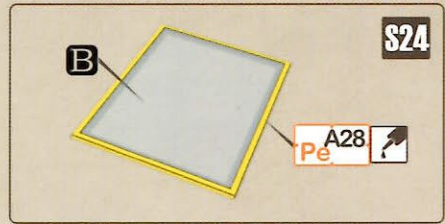
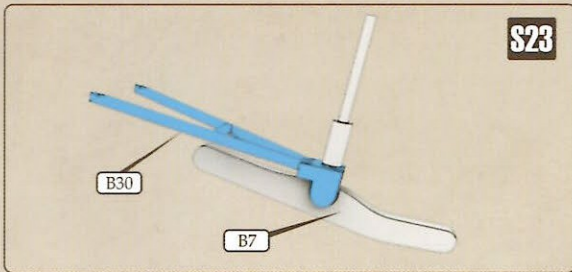

X Bombs and propeller

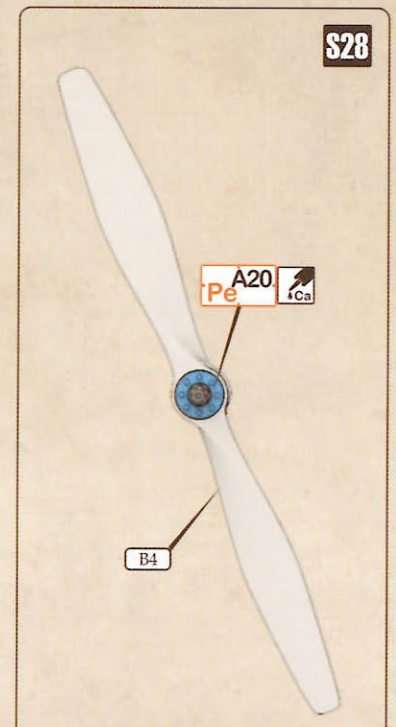
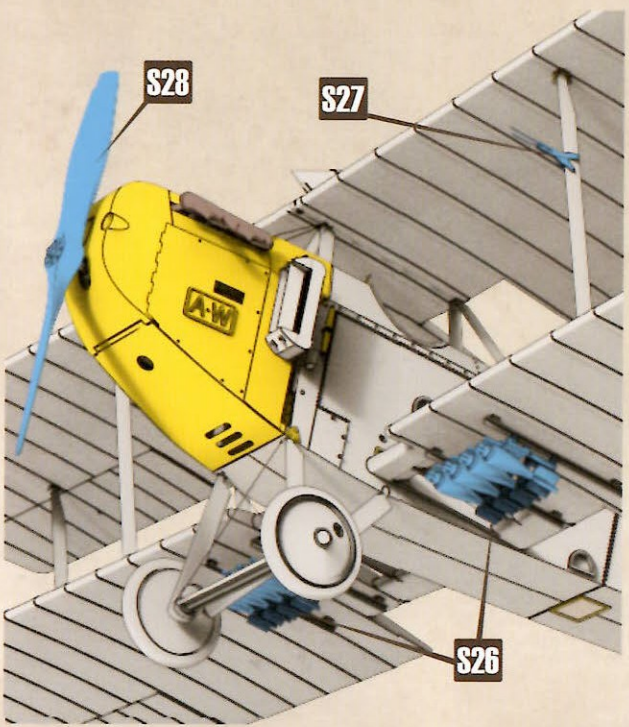
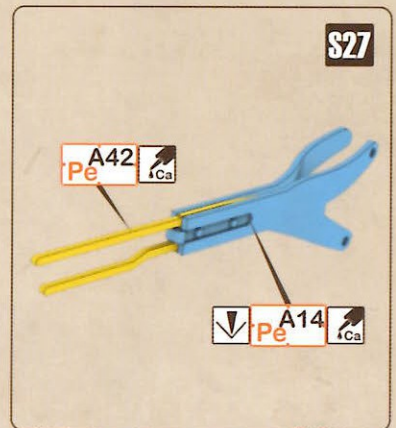
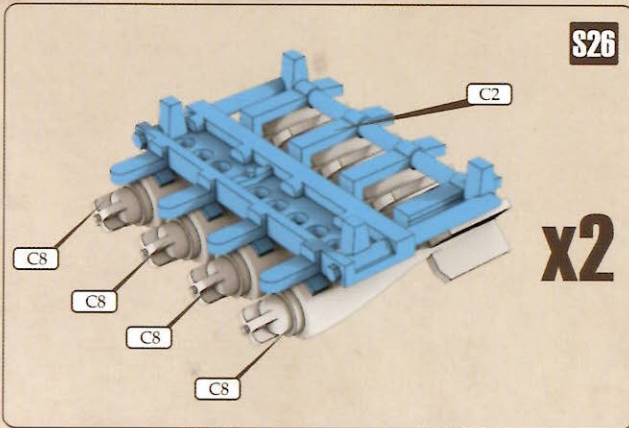
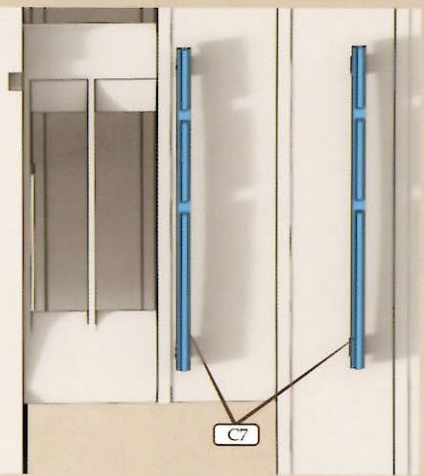
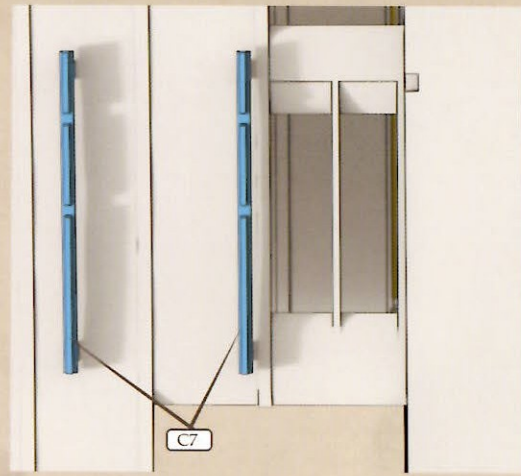

XI Rigging

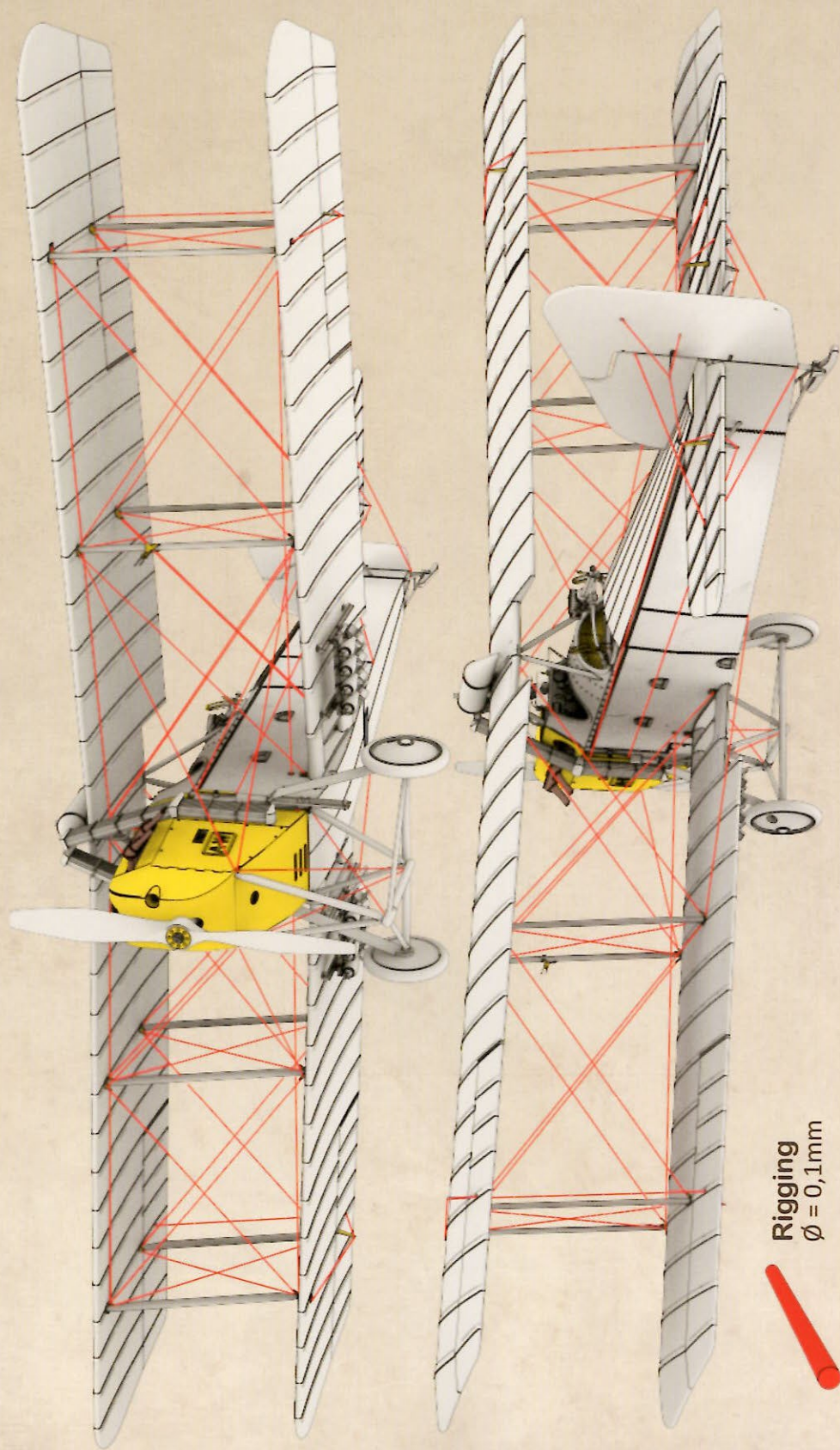

Rigging
 $\varnothing = 0,1\text{mm}$

XII Paint colours and markings

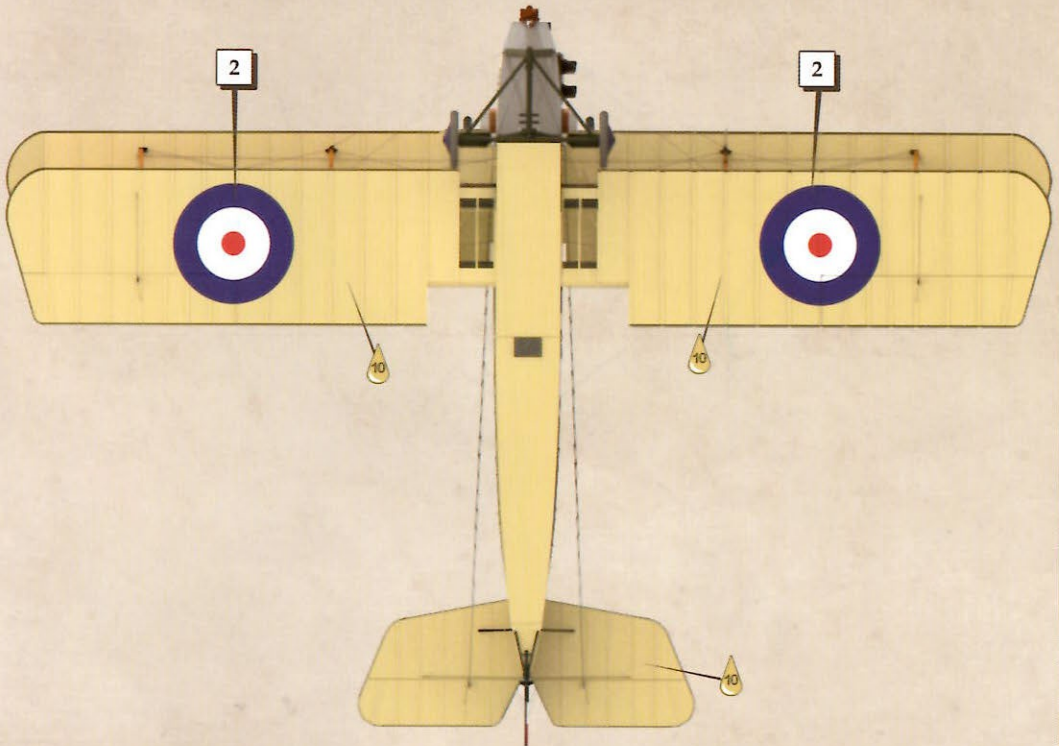
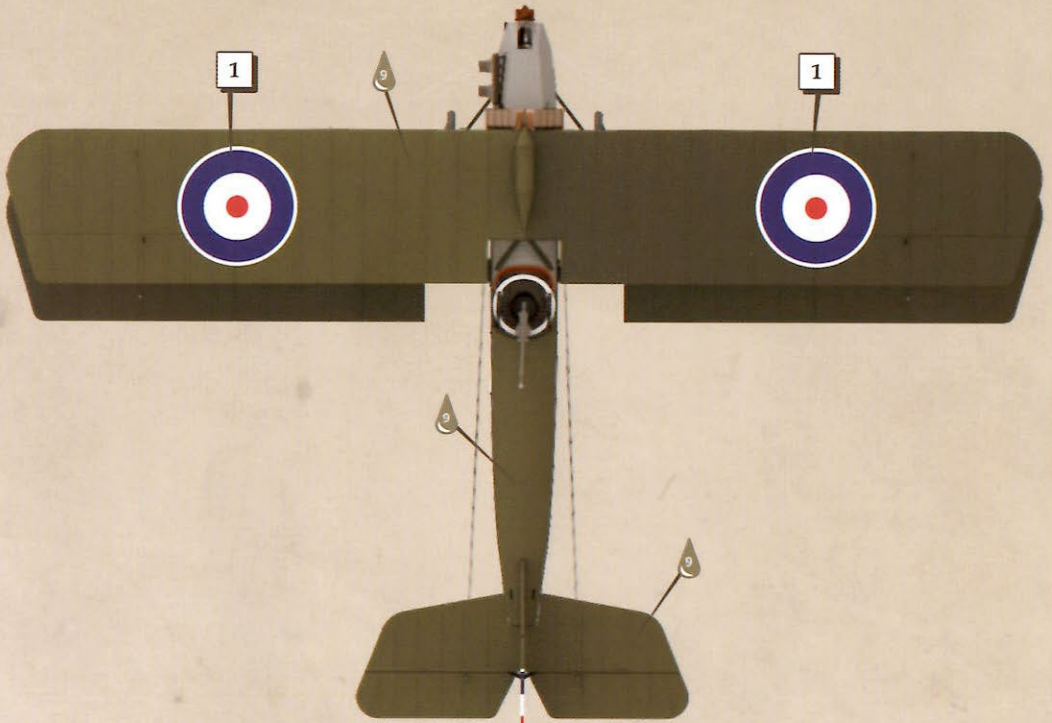
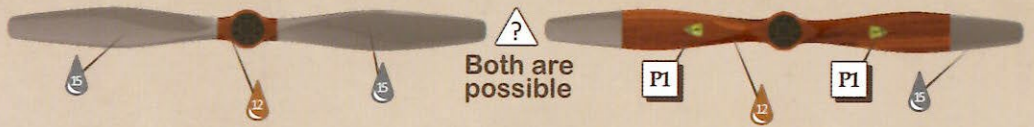

XII Paint colours and markings

A Armstrong Whitworth F.K.8 B-5782 No.2 Sqn RFC, December 1917

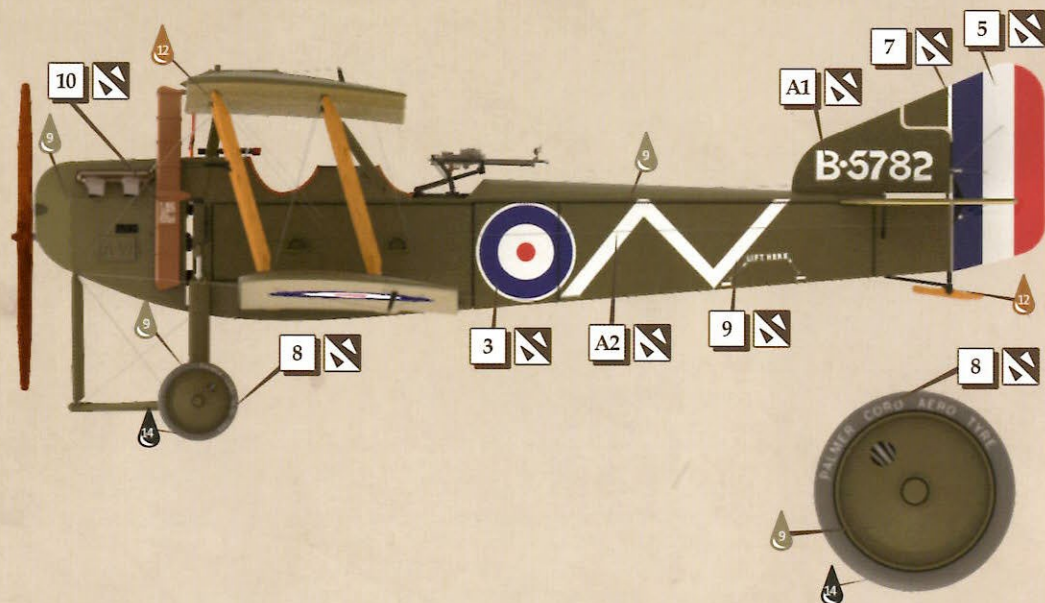

B Armstrong Whitworth F.K.8 B5773 No.2 Sqn RFC, 2Lt. Alan A. McLeod won the Victoria Cross flying this aeroplane on 27 March 1918

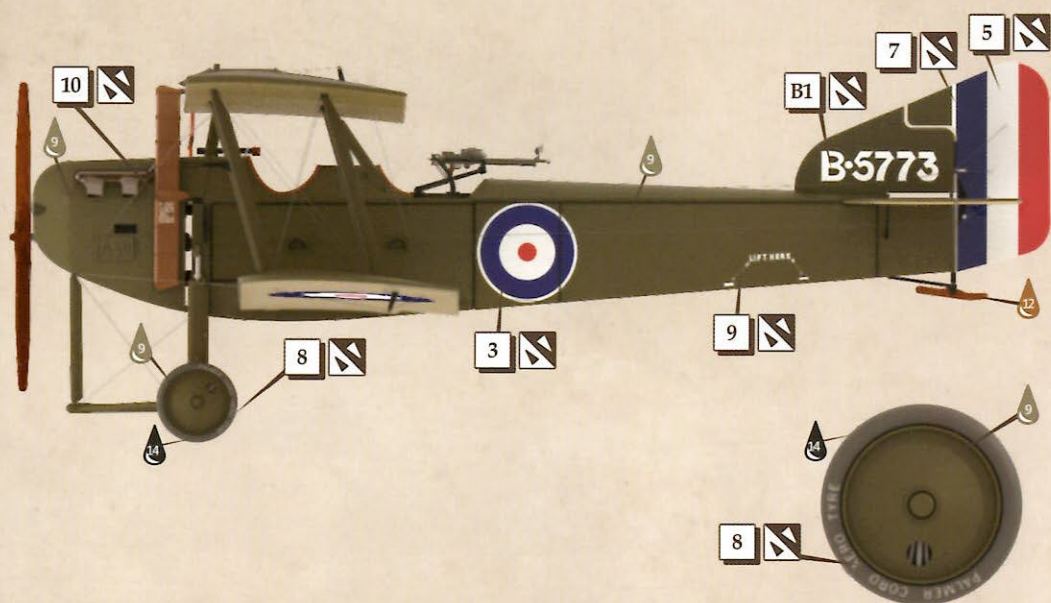

XII Paint colours and markings

C Armstrong Whitworth F.K.8 B-213 No.39 Sqn RFC, June 1917

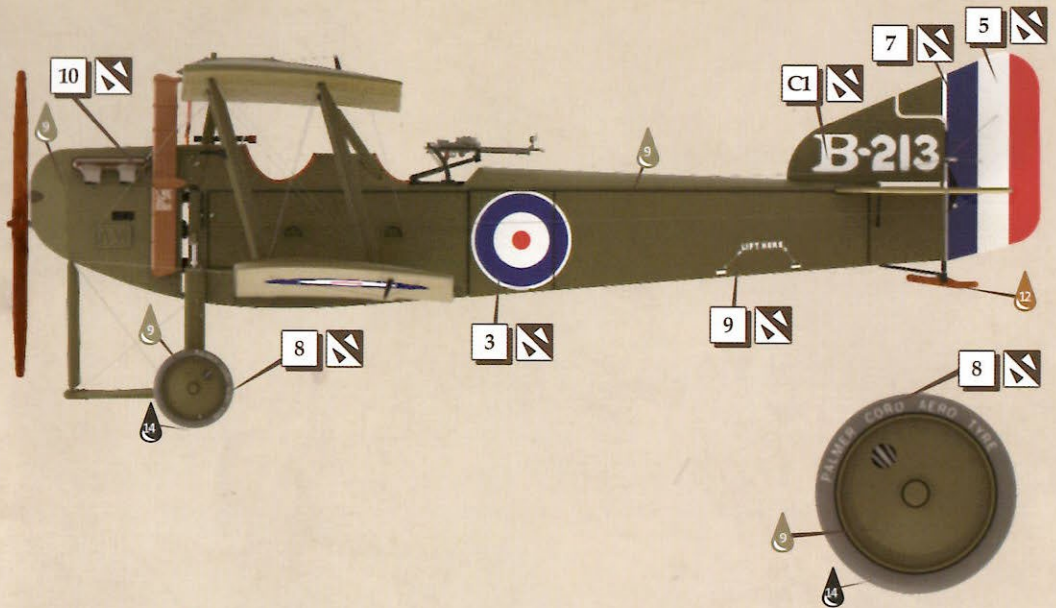

D Armstrong Whitworth F.K.8 C.3549 No.35 Sqn RFC, December 1917

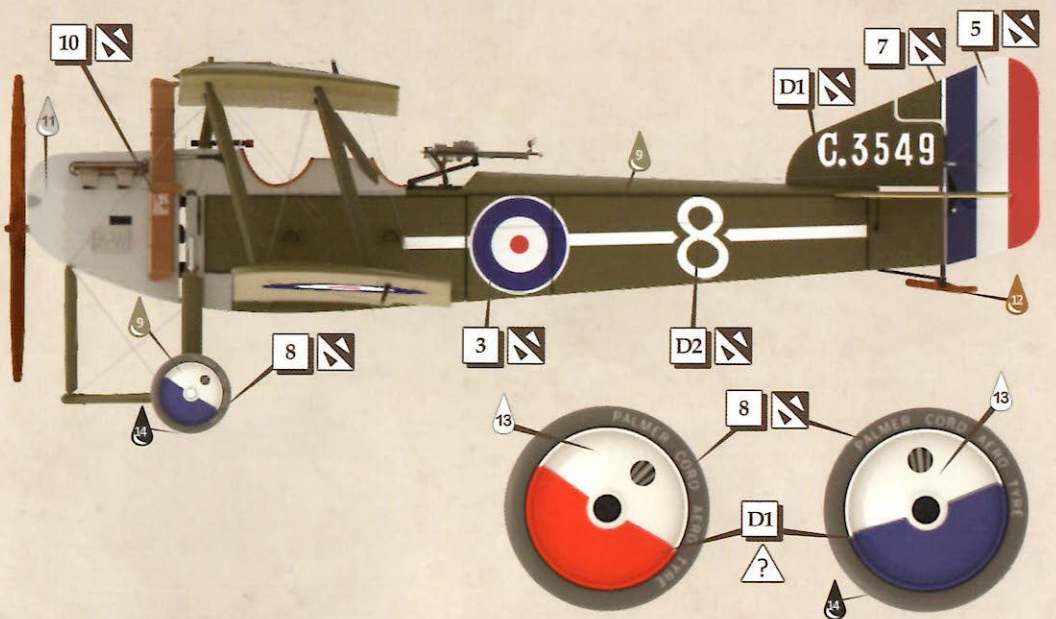



Copper State Models team would like to thank:

Bob Pearson - Canada
David Hooper - England, United Kingdom
David Wilson - Australia
Des Delatorre (ww1aircraftmodels.com) - Australia
Gennady Nechaeff - Russia
Kajetan Schulz (Meliusmanu.pl) - Poland
Oleg Tuleninov - Latvia

for all your help and continued support.

Already at our online store



1026 - Sopwith 5F.1 Dolphin



1027 - Caudron G.IV Late version



1028 - Caudron G.IV Hydravion



1031 - Armstrong-Whitworth
F.K.8 Late production version

www.copperstatemodels.com

 <https://www.facebook.com/copperstatemodels/>