

**eduard**

# Jabo

Fw 190A-5/U3, U8

1/48



**Instruction sheet**

11131-NAD1

ATTENTION



UPOZORNĚNÍ



ACHTUNG



ATTENTION



注意



Carefully read instruction sheet before assembling. When you use glue or paint, do not use near open flame and use in well ventilated room. Keep out of reach of small children. Children must not be allowed to suck any part, or pull vinyl bag over the head.



Před započítím stavby si pečlivě prostudujte stavební návod. Při používání barev a lepidel pracujte v dobře větrané místnosti. Lepidla ani barvy nepoužívejte v blízkosti otevřeného ohně. Model není určen malým dětem, mohlo by dojít k požití drobných dílů.

INSTRUCTION SIGNS \* INSTR. SYMBOL \* INSTRUKTION SINNBILDEN \* SYMBOLES \* 記号の説明

OPTIONAL  
VOLBABEND  
OHNOUTSAND  
BROUSITOPEN HOLE  
VYVRTAT OTVORSYMETRICAL ASSEMBLY  
SYMETRICKÁ MONTÁŽREMOVE  
ODŘÍZNOUTREVERSE SIDE  
OTOČITAPPLY EDUARD MASK  
AND PAINT  
POUŽIT EDUARD MASK  
NABARVIT

PARTS



DÍLY



TEILE



PIÈCES



部品

PLASTIC PARTS

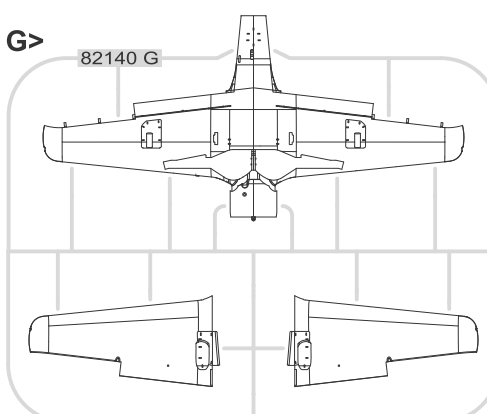
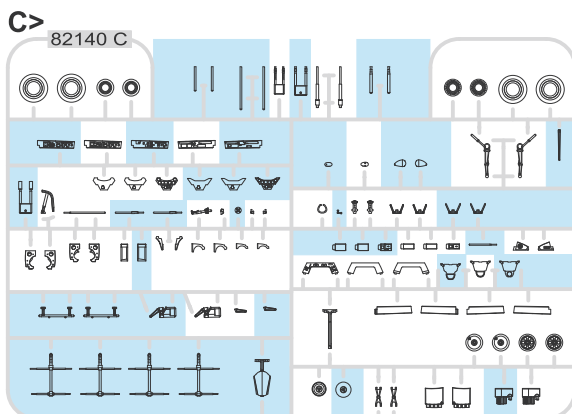
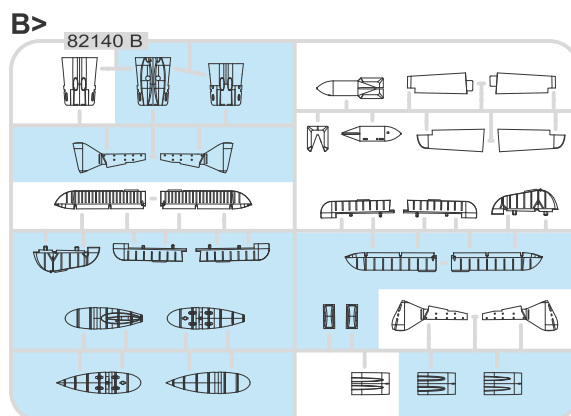
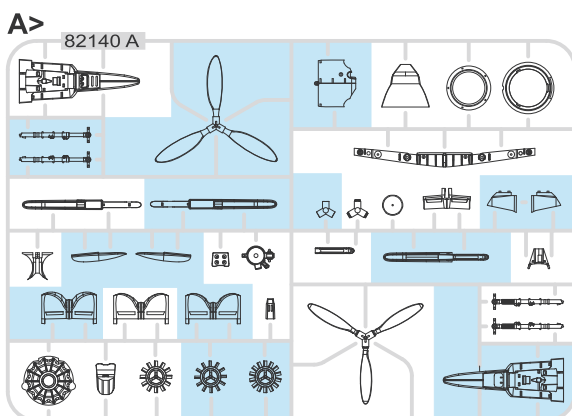

RP - RESIN PARTS

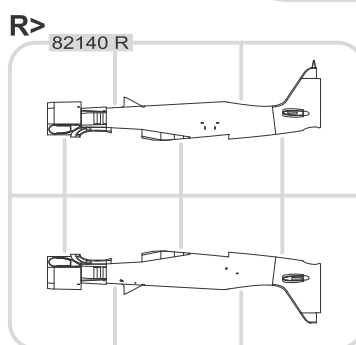
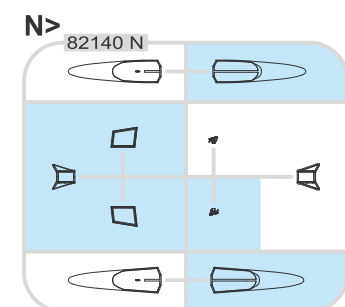
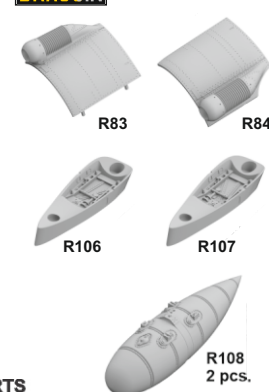

PE - PHOTO ETCHED DETAIL PARTS

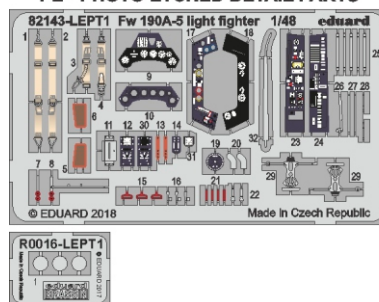

-Parts not for use. -Teile werden nicht verwendet. -Pièces à ne pas utiliser. -Tyto díly nepoužívejte při stavbě. - 使用しない部品

COLOURS



BARVY



FARBEN



PEINTURE



色

GSI Creos (GUNZE)		MISSION MODELS	
AQUEOUS	Mr.COLOR	PAINTS	
H1	C1	[MMP-001]	WHITE
H2	C2	[MMP-047]	BLACK
H11	C62	[MMP-001]	FLAT WHITE
H12	C33	[MMP-047]	FLAT BLACK
H33	C81		RUSSET
H47	C41	[MMP-012]	RED BROWN
H65	C18	[MMP-088]	RLM70 BLACK GREEN
H68	C36	[MMP-049]	RLM74 DARK GRAY
H69	C37	[MMP-050]	RLM75 GRAY
H70	C60	[MMP-056]	RLM02 GRAY
H77	C137	[MMP-040]	TIRE BLACK
H80	C54		KHAKI GREEN

GSI Creos (GUNZE)		MISSION MODELS	
AQUEOUS	Mr.COLOR	PAINTS	
H90	C47		CLEAR RED
H94	C138		CLEAR GREEN
H413	C113	[MMP-090]	RLM04 YELLOW
H414	C114		RLM23 RED
H416	C116	[MMP-089]	RLM66 BLACK GRAY
H417	C117	[MMP-051]	RLM76 LIGHT BLUE
Mr.METAL COLOR		METALLICS	
MC213		[MMM-006]	STEEL
MC214		[MMM-001]	DARK IRON
Mr.COLOR SUPER METALLIC		METALLICS	
SM206/SM06		[MMC-001]	SUPER CHROME SILVER

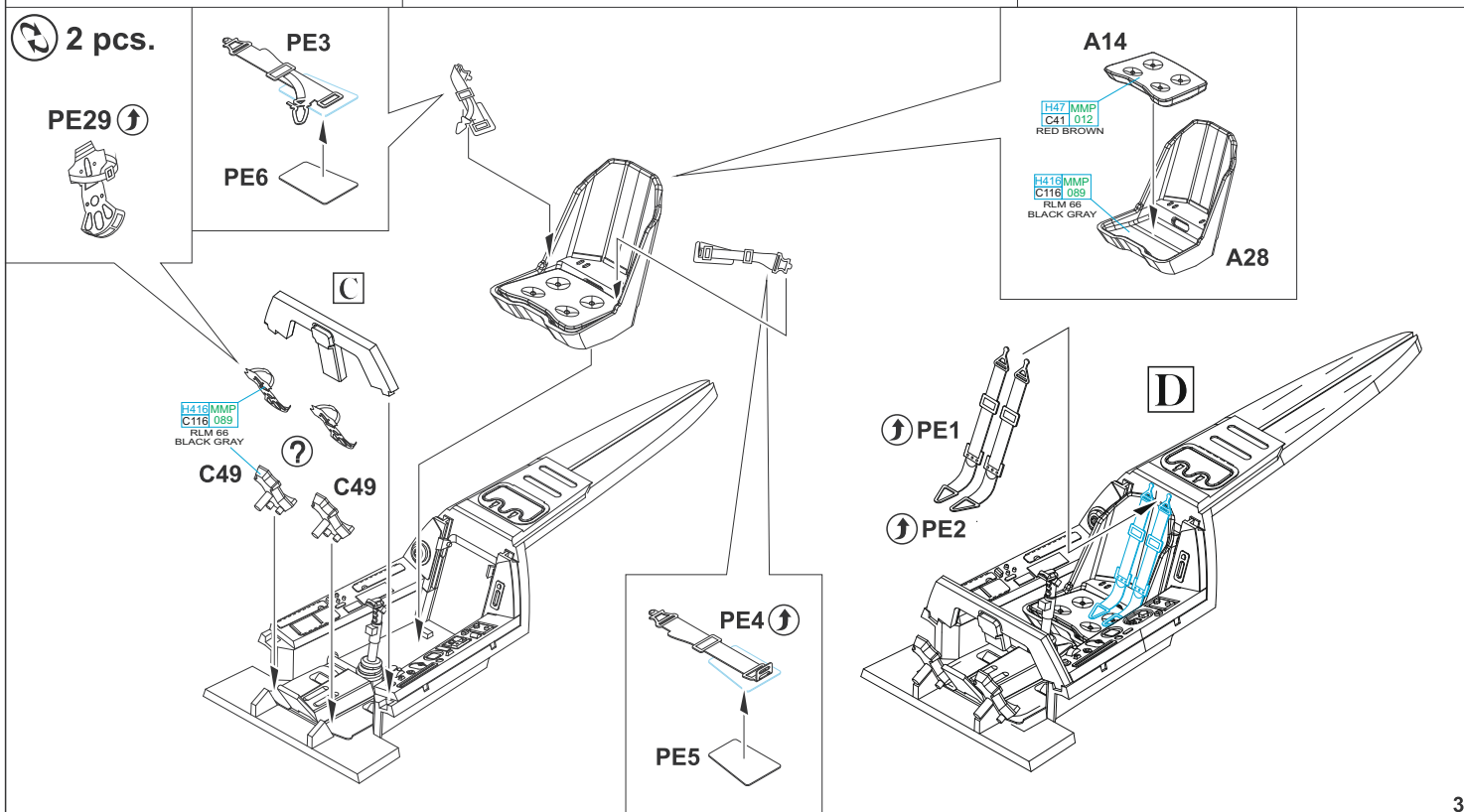
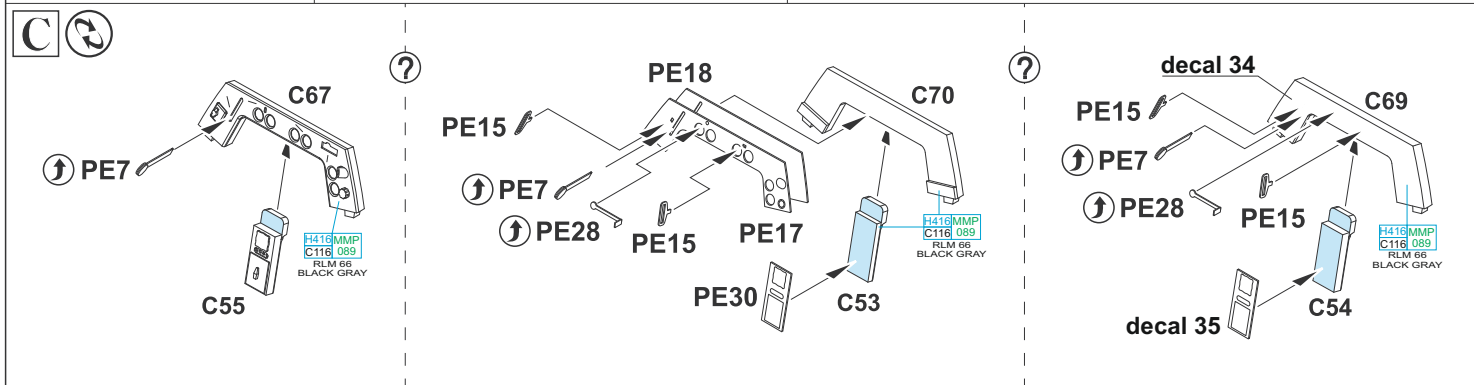
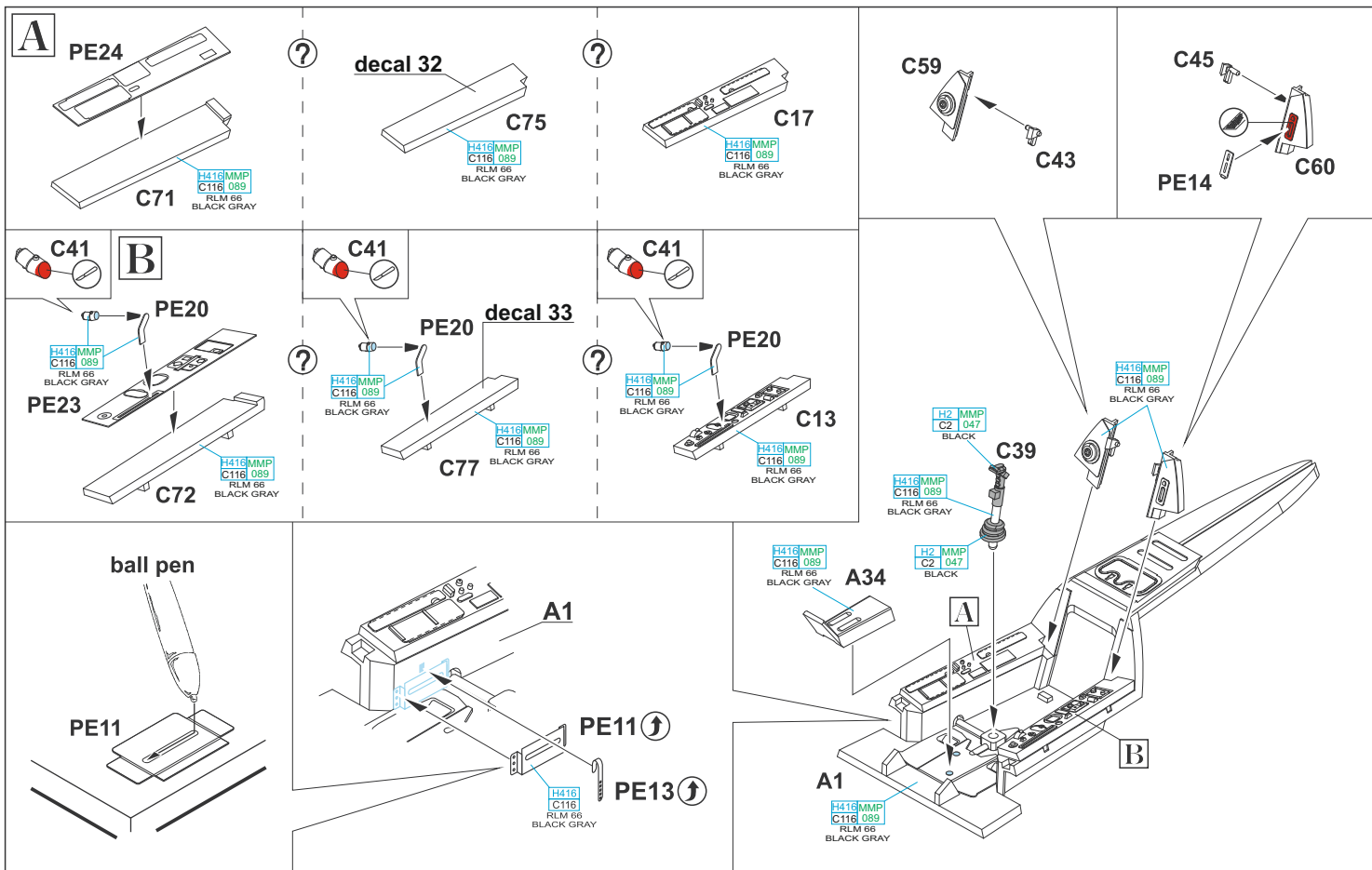

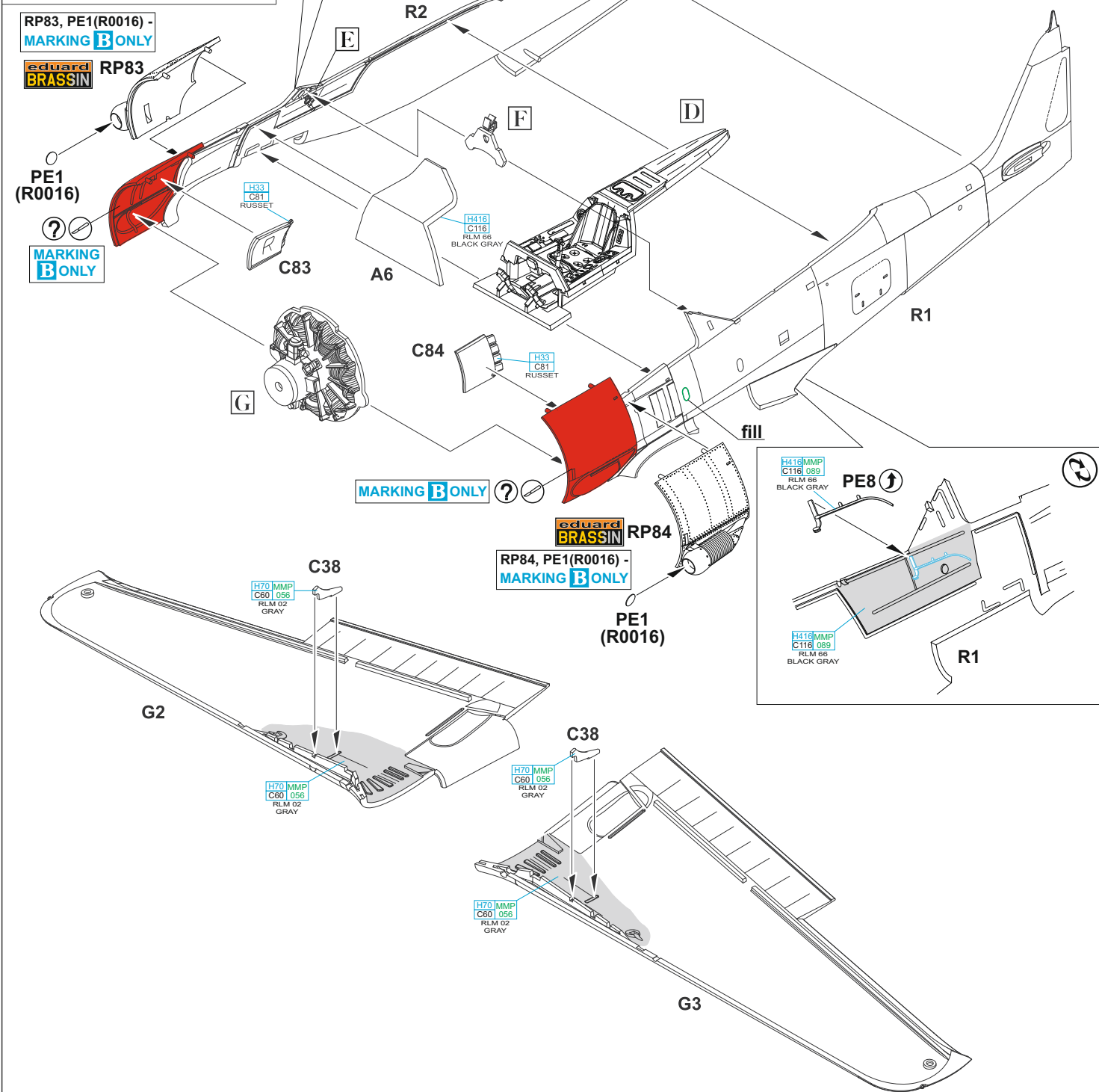
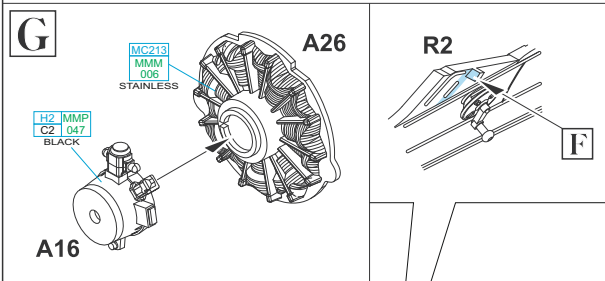
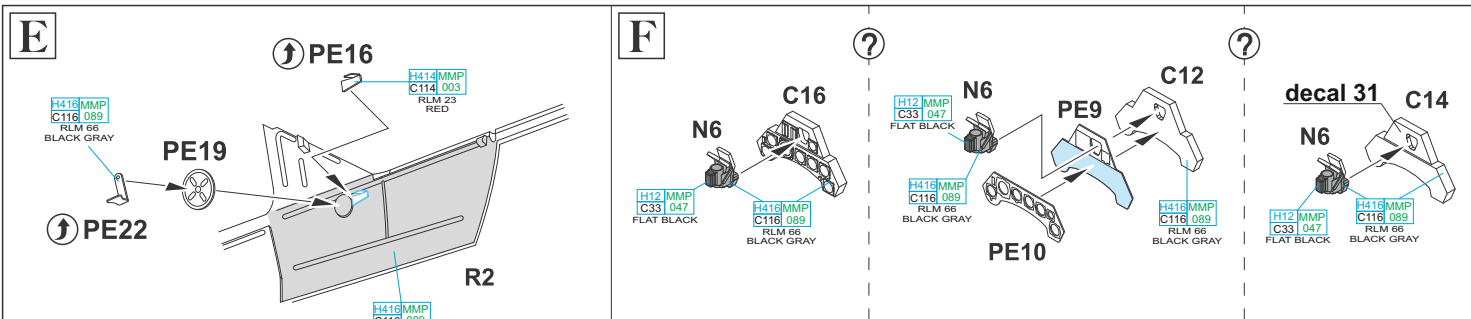

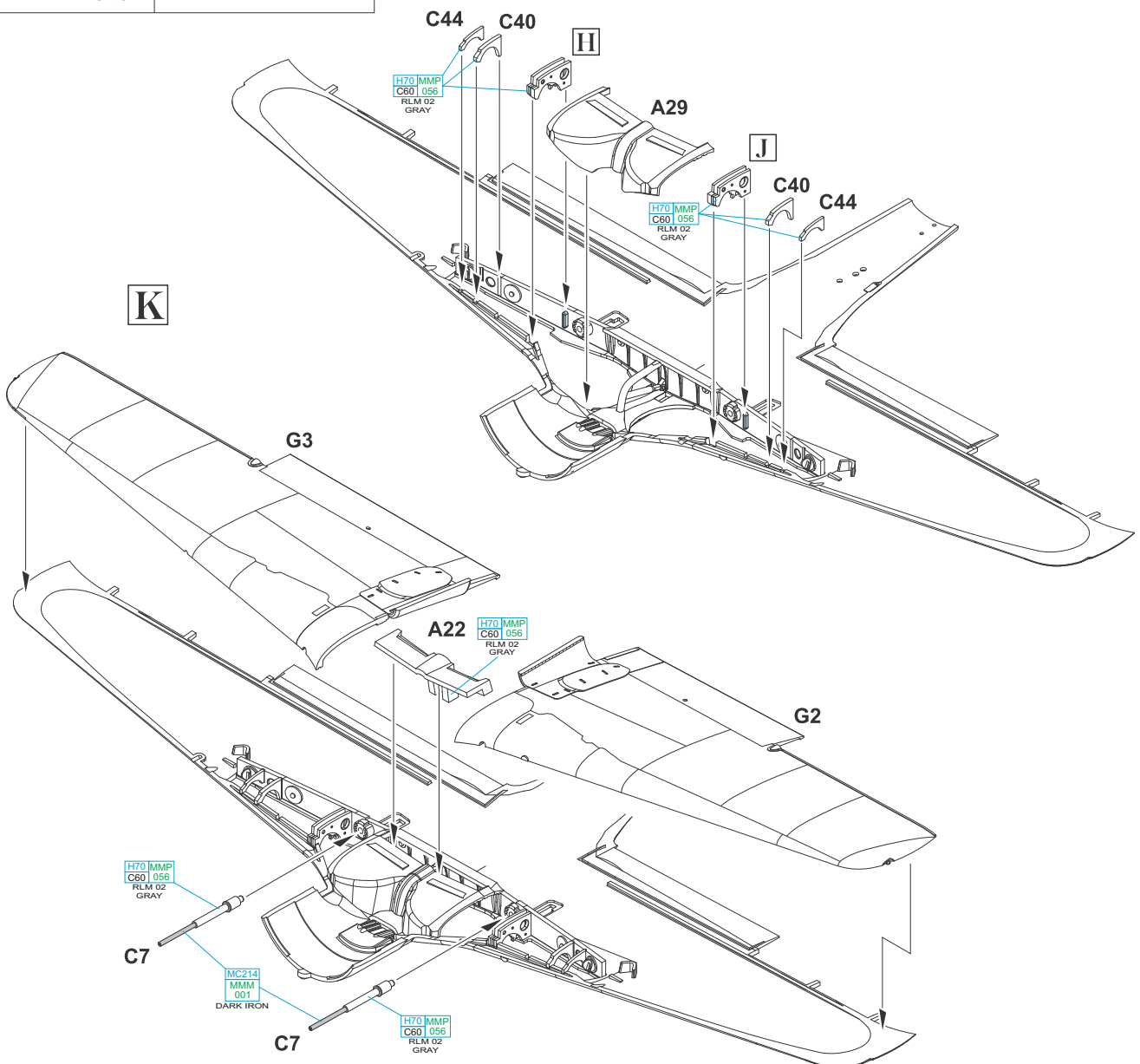
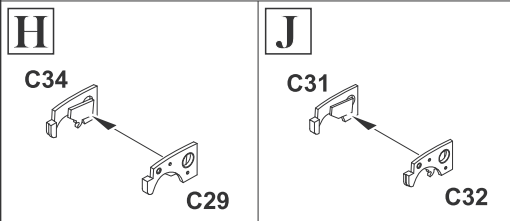
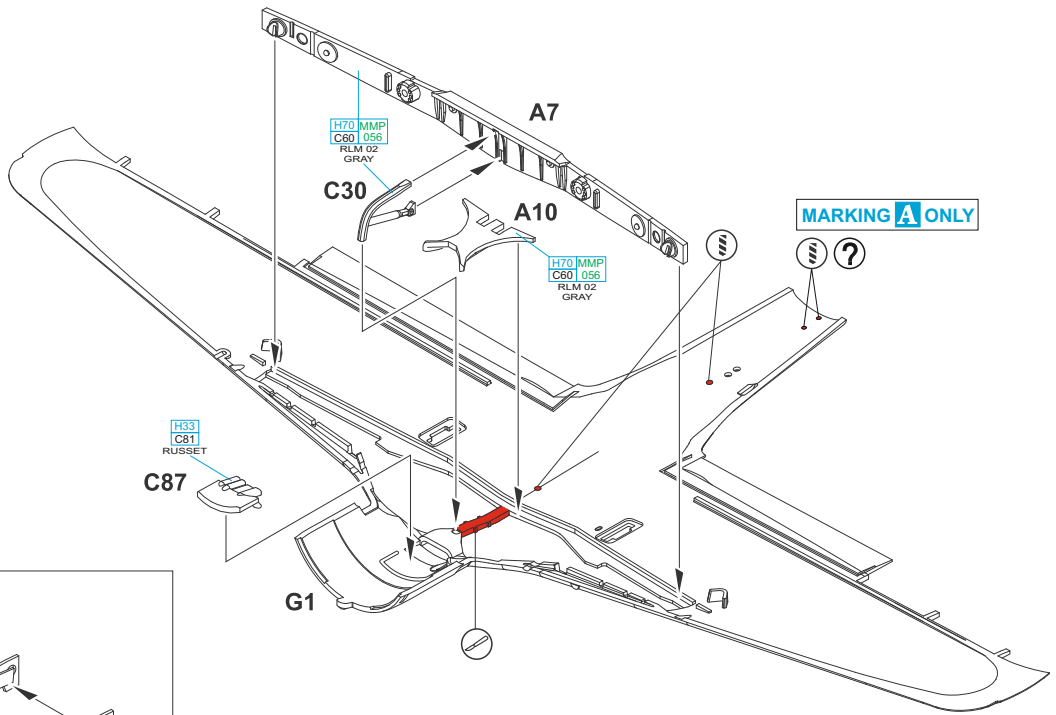

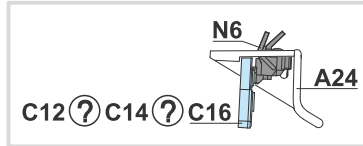
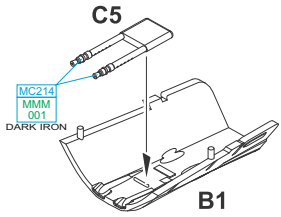

H84  
C138  
CLEAR GREEN

**B29**

H418 MMP  
C116 099  
RLM 66  
BLACK GRAY

**A24**

H47 MMP  
C41 012  
RED BROWN

**K**

H80  
C47  
CLEAR RED

**L**

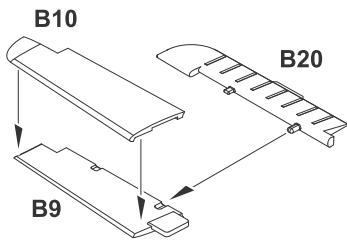

**M**

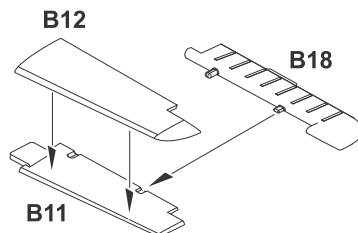

**B22**

H11 MMP  
C1 001  
WHITE

**L**

**M**

**B14**

**A9**

H70 MMP  
C80 056  
RLM 02  
GRAY

**A8**

H70 MMP  
C80 056  
RLM 02  
GRAY

**B16**

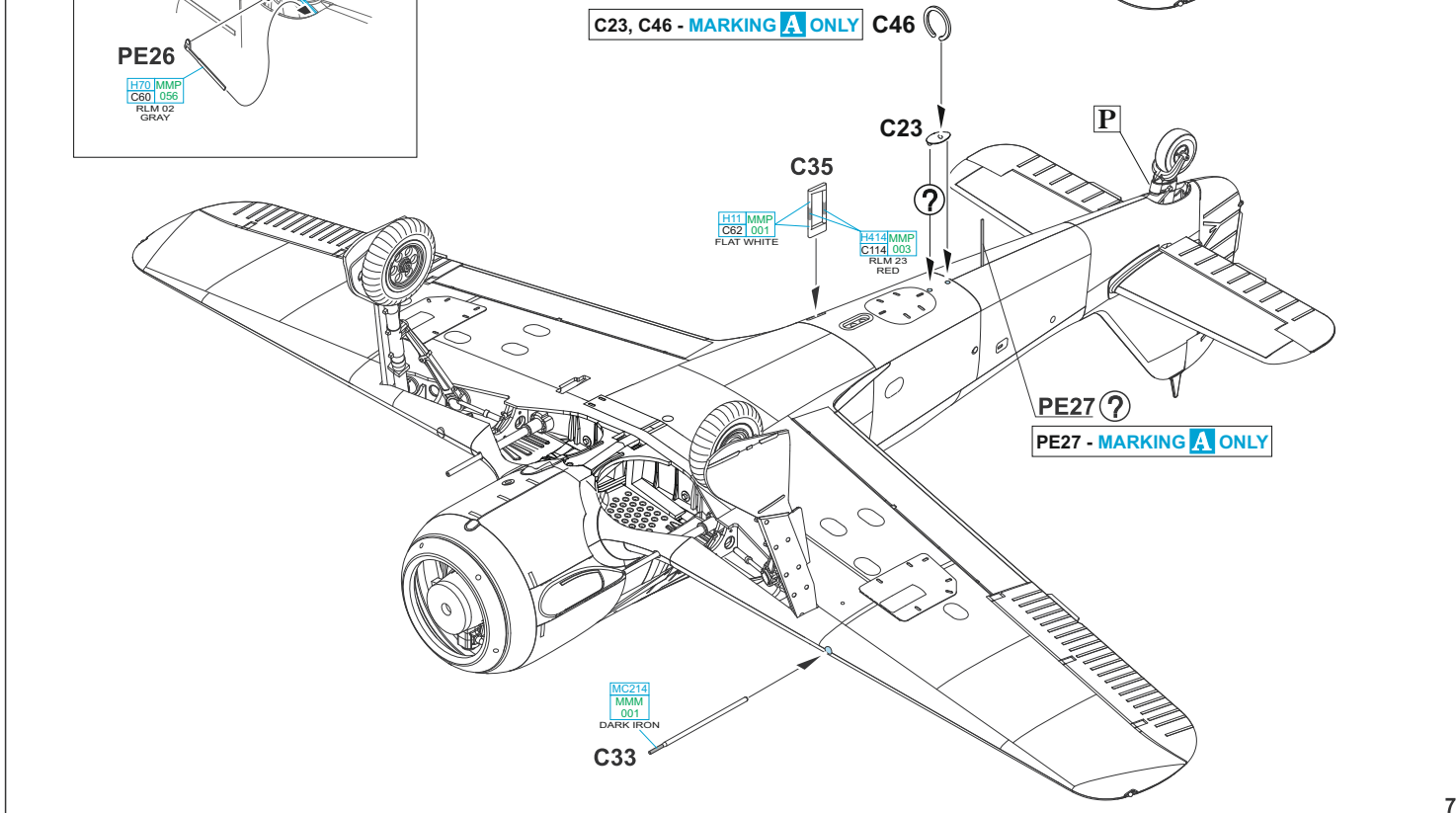
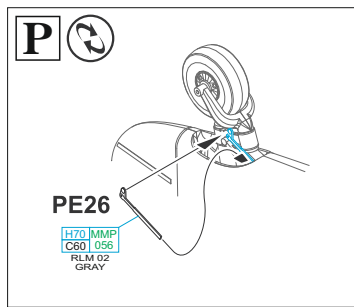
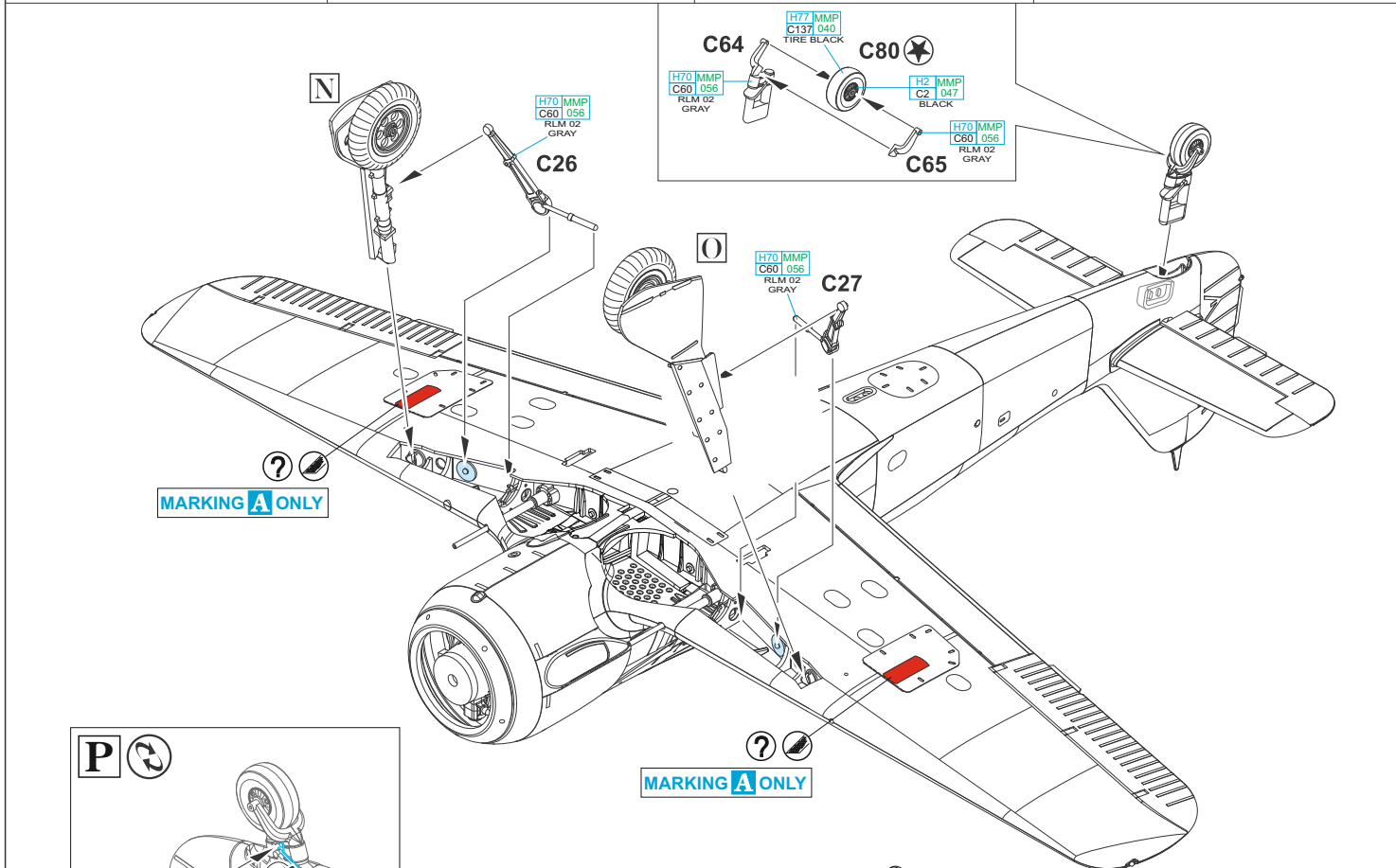
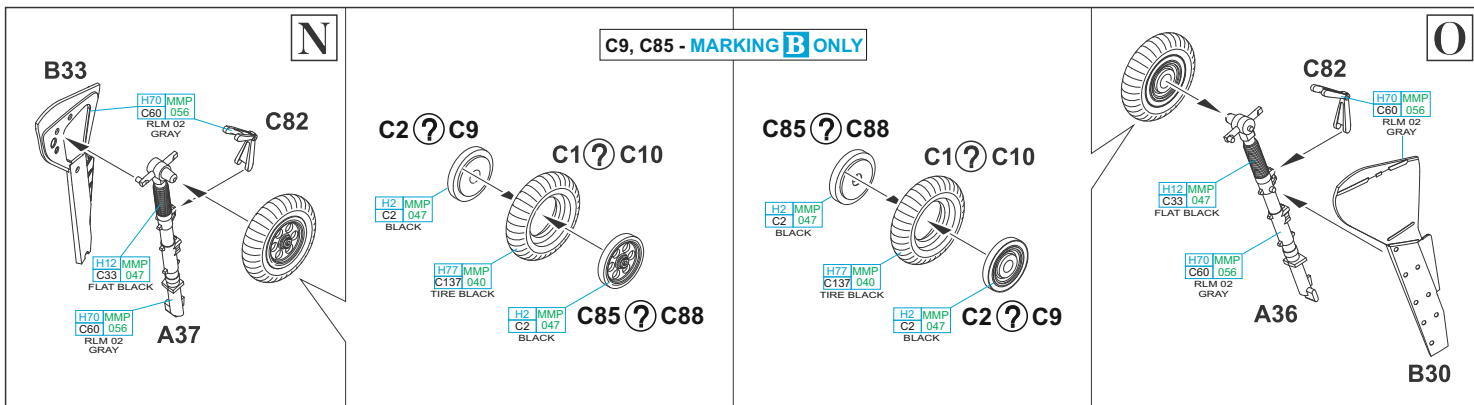

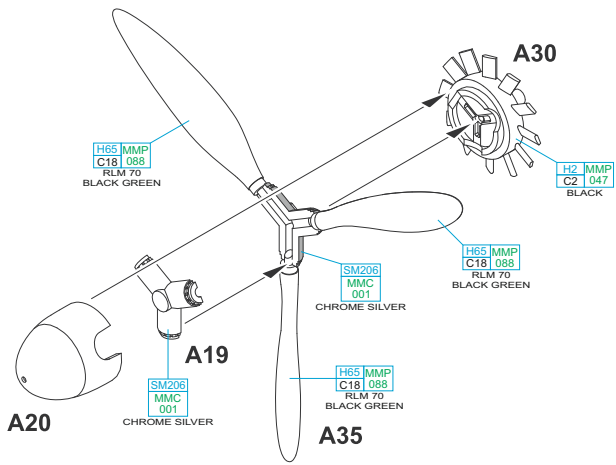
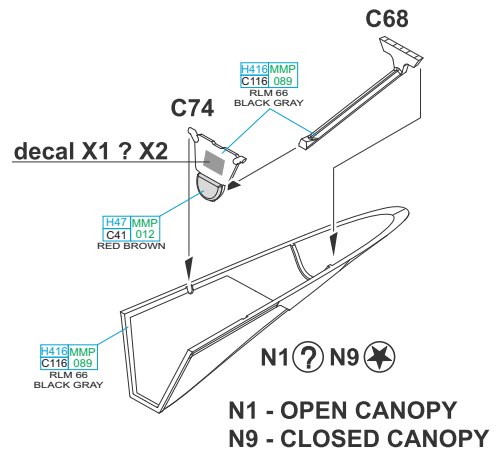
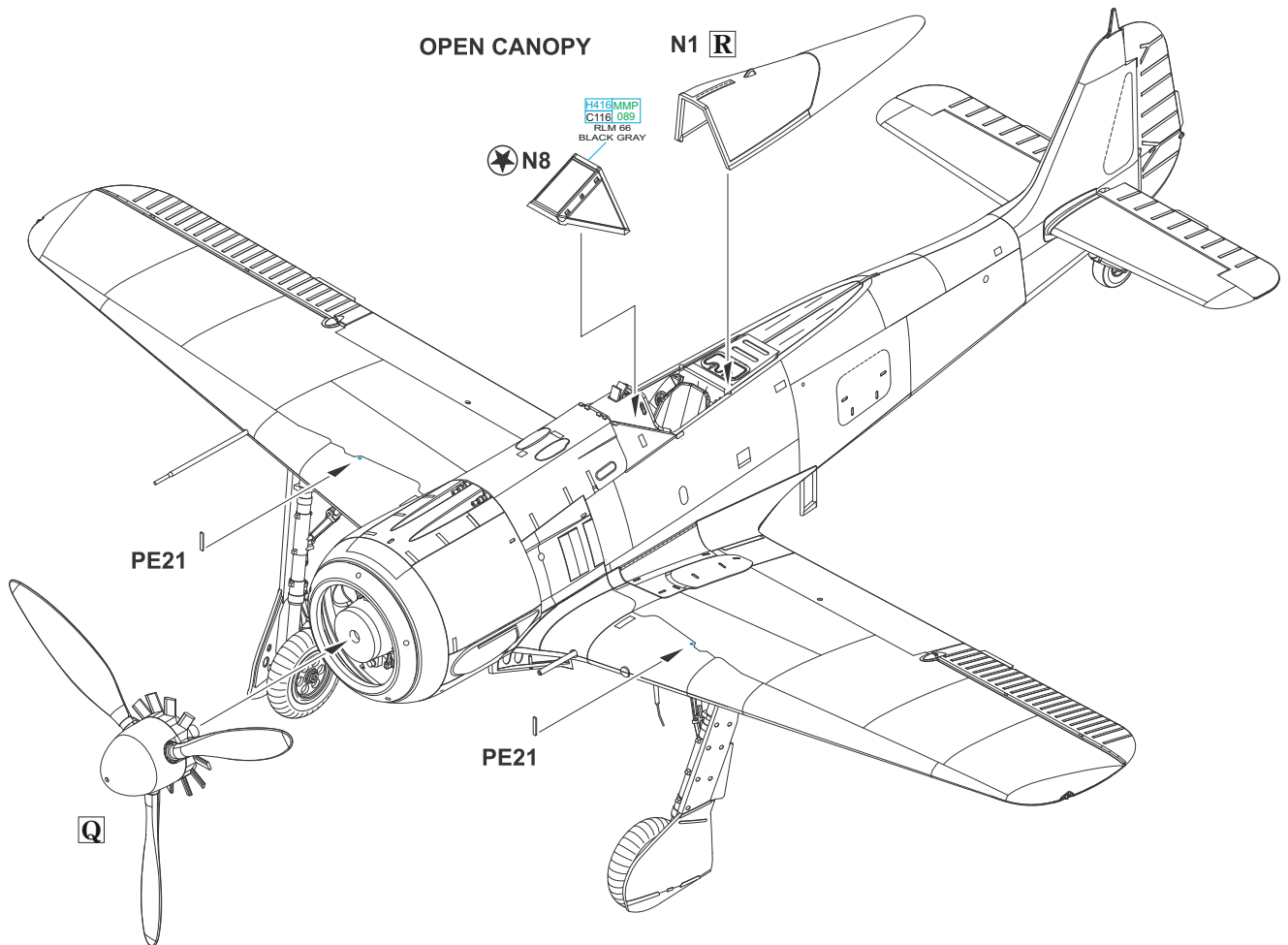
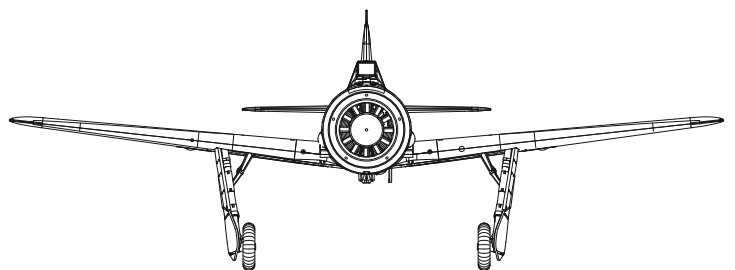
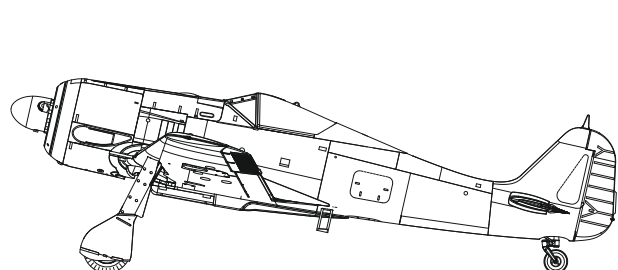
**Q****R****OPEN CANOPY****N1 R****Q**



CLOSED CANOPY

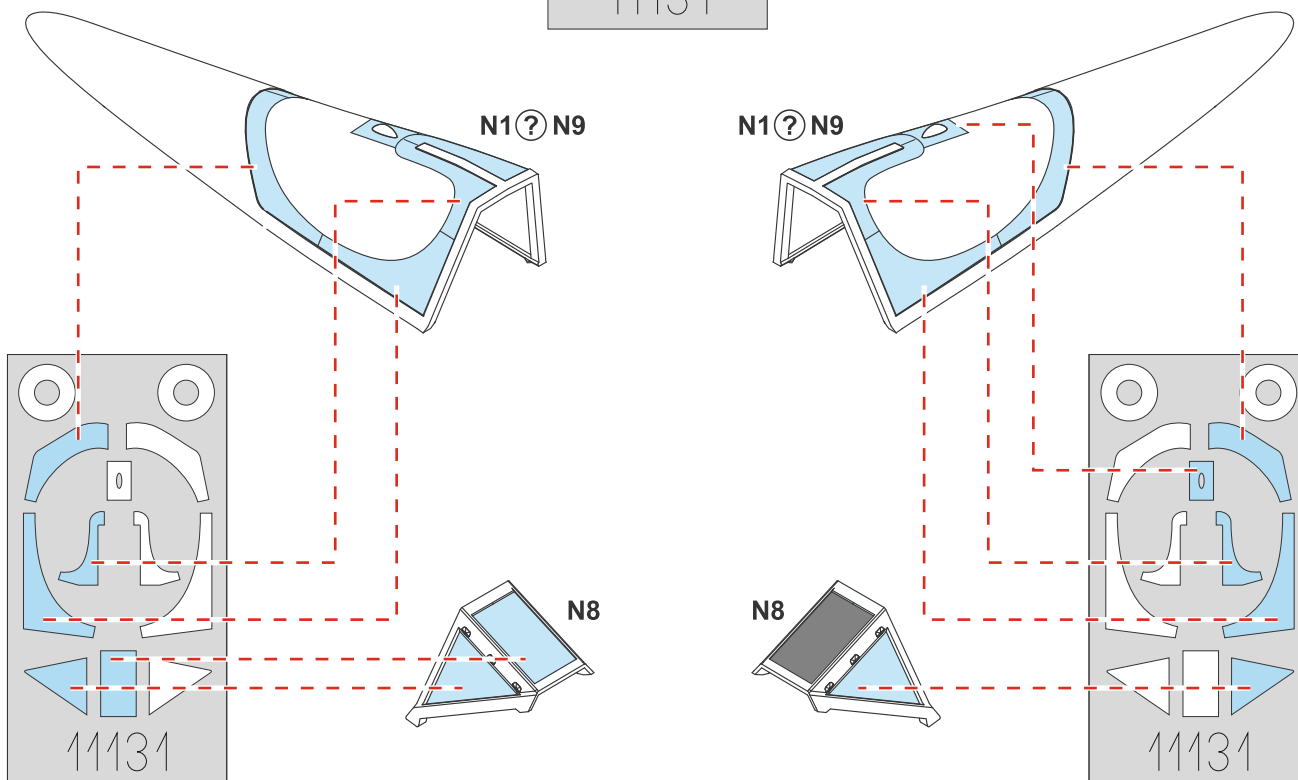
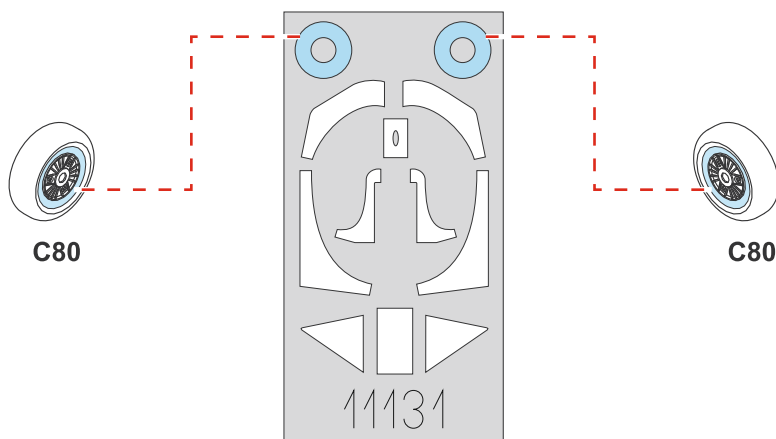
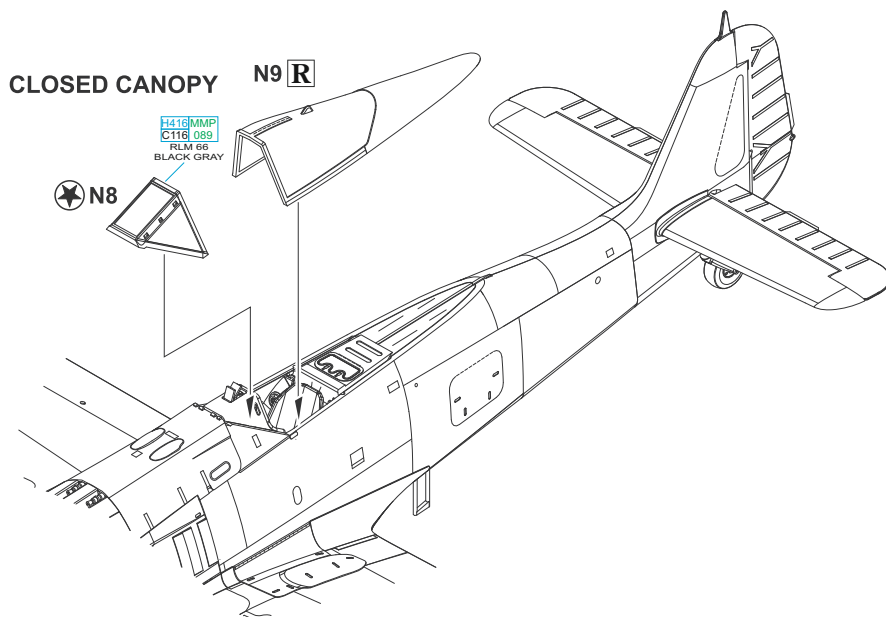

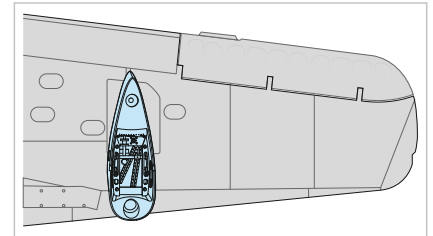
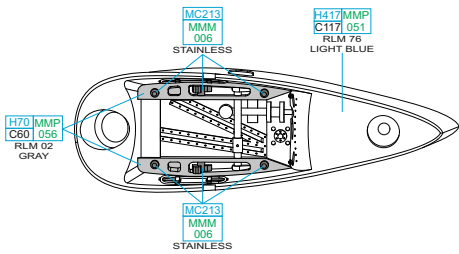
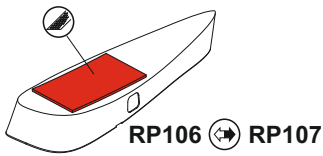
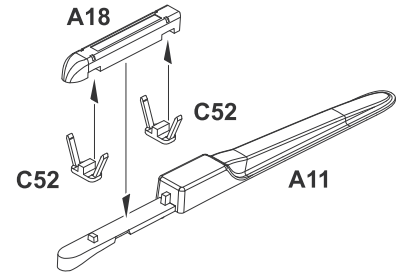
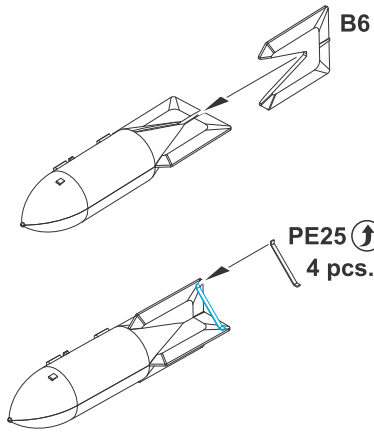
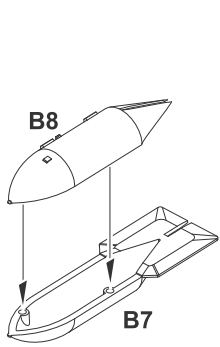

RP106, RP108 - MARKING A ONLY

RP107, RP108 - MARKING A ONLY

RP108

eduard  
BRASSIN

RP107

H80 C54  
KHAKE GREEN

H417 MMP  
C171 051  
RLM 76  
LIGHT BLUE

RP108

eduard  
BRASSIN

RP106

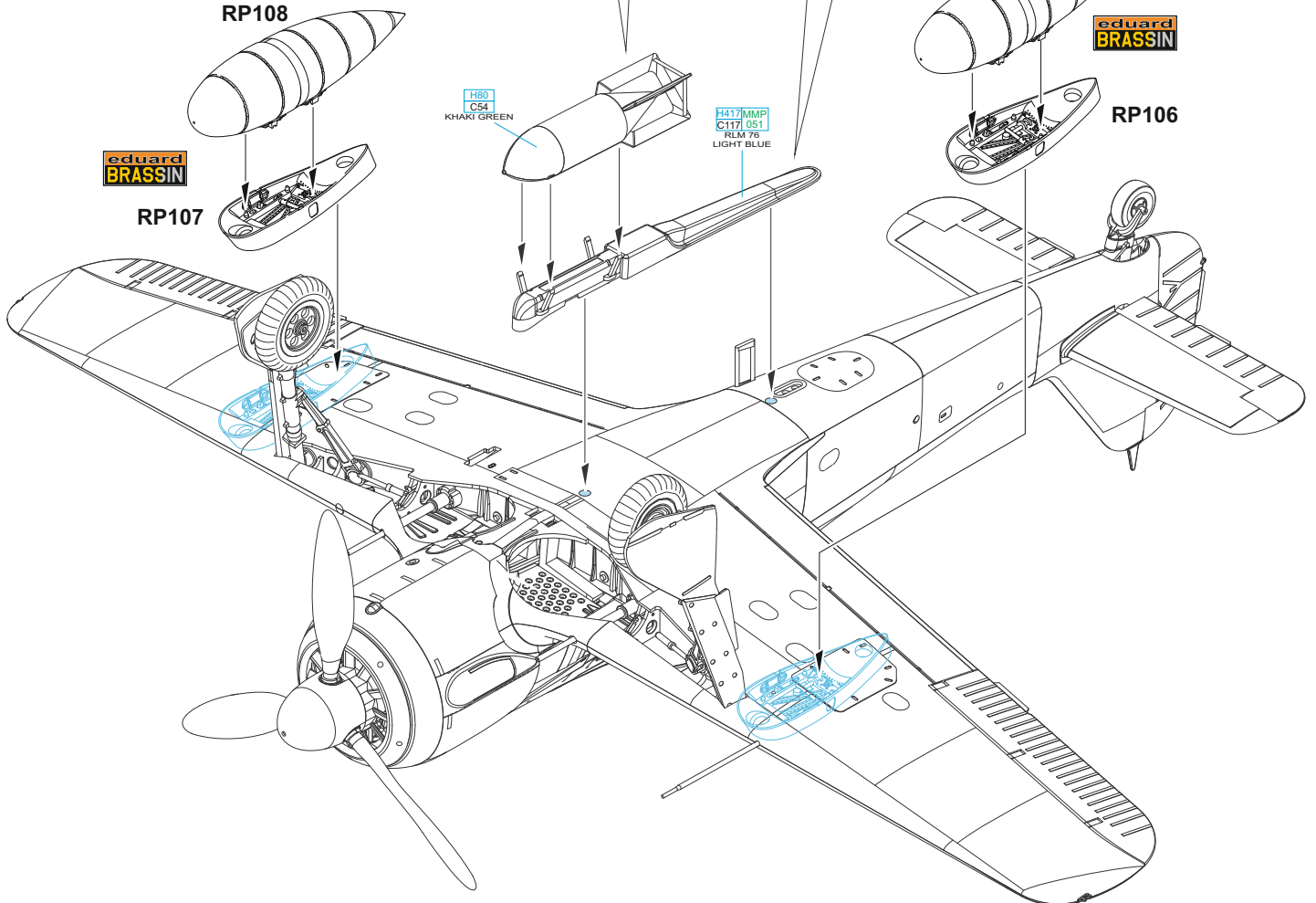

# A Fw 190A-5/U8, W. Nr. 152596, flown by Uffz. Werner Öhne, 1./SKG 10, Poix, France, June 1943

During the night of July 19th -20th, 1943, 1./SKG 10 engaged in the bombing raid against the city of Ramsgate. During the flight Uffz. Öhne lost the radio contact, moreover he soon got lost in the thick clouds. Through the gap in the cloud cover he spotted he was flying over the sea and he noticed the coast in the South. He believed it was the French coast, he headed in that direction and released the bomb on the way. In the reality he was over the wide mouth of the river Thames and further flight brought him to Manston airport when he landed without any damage. Consequently, RAF utilized this aircraft to develop the combat tactics against Focke Wulfs. The aircraft of this unit, used mostly for the night bombing raids, had the lower and partially the side surfaces overpainted in the black color including the crosses on the wing lower surfaces, swastika and the rudder, originally painted yellow. To extend their range the drop tank attachments were installed under the wing, initially developed for the use on Ju 87 aircraft.

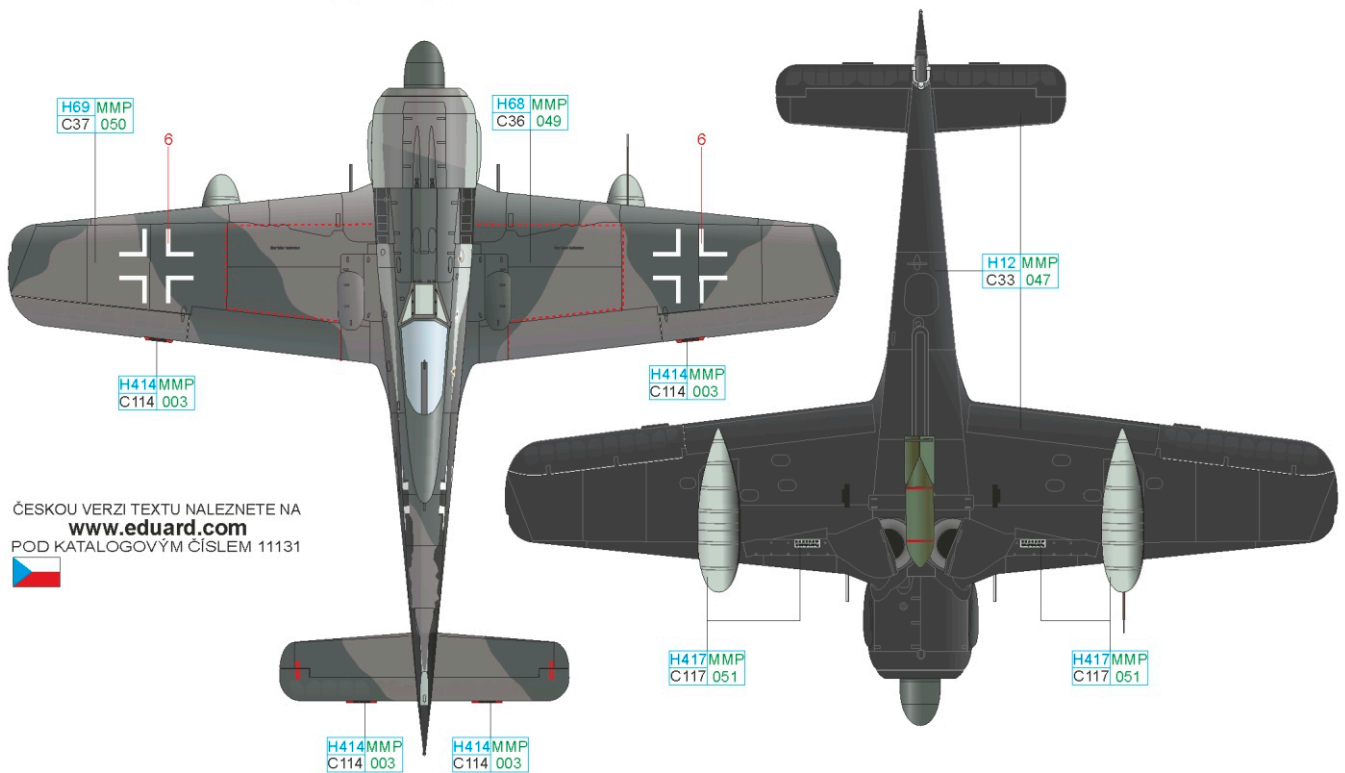
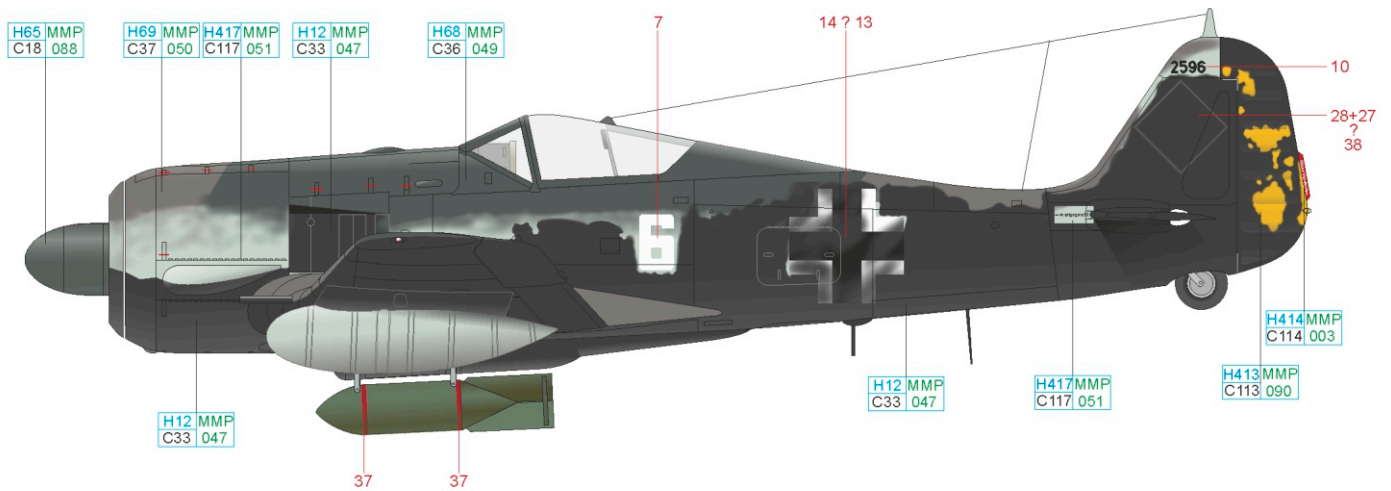

ČESKOU VERZI TEXTU NALEZNETE NA  
[www.eduard.com](http://www.eduard.com)  
POD KATALOGOVÝM ČÍSLEM 11131

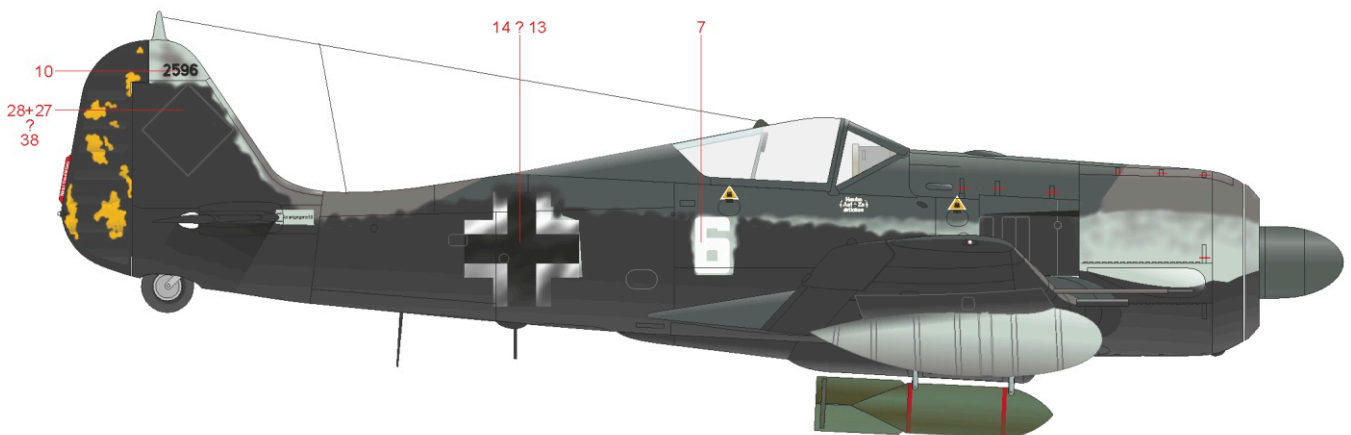

RLM 70	H65 MMP C18 088	RLM 23	H414 MMP C114 003	RLM 04	H413 MMP C113 090
RLM 74	H68 MMP C36 049	RLM 75	H69 MMP C37 050	RLM 76	H417 MMP C117 051
			BLACK	H12 MMP C33 047	

# B Fw 190A-5/U3, W. Nr. 0150 1437, flown by Ofw. Johannsen, 7./SchG. 2, Catania, Sicily, July 1943

After capturing Catania and the nearby airport by British XIII. Corps on August 5th, 1943, this aircraft was discovered on the airbase. Two days ago, Ofw. Johannsen had landed it here due to the engine troubles, the following day the airplane was damaged by Allied aircraft attacking the airport. The aircraft operating with the attack units were marked with the letters as opposed to the fighter units which marked their airplanes with numbers. The letter "O" in yellow, indicating 7. Staffel, was accompanied by the yellow color of the vertical stabilizer and rudder indicating I. and II. Gruppe SchG. 2. On the engine cowling the aircraft carried the II./SchG. 2 insignia – Mickey Mouse sitting on the bomb and holding an ax in the hand.

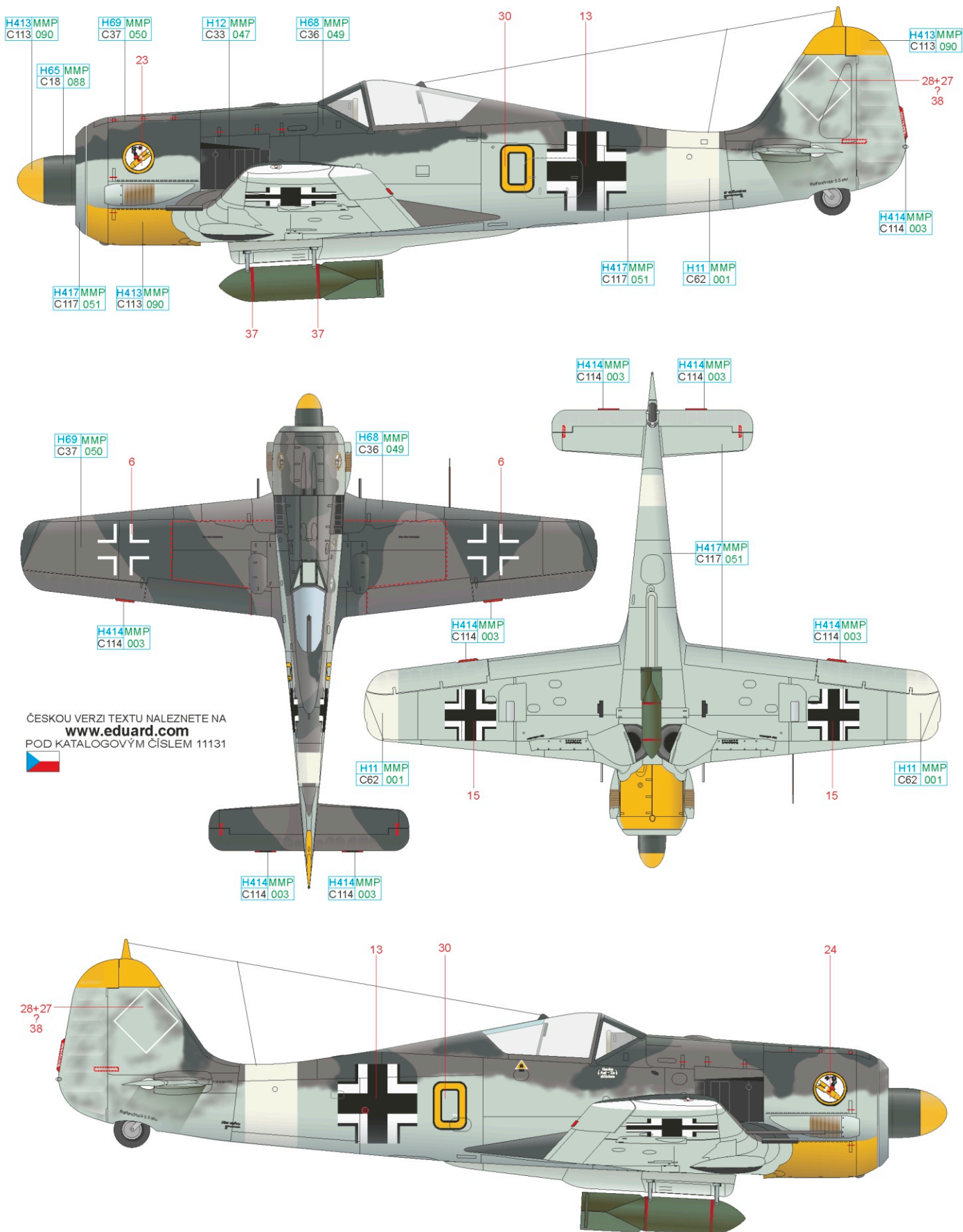

ČESKOU VERZI TEXTU NALEZNETE NA  
[www.eduard.com](http://www.eduard.com)  
 POD KATALOGOVÝM ČÍSLEM 11131



RLM 70	H65 MMP C18 088	RLM 23	H414 MMP C114 003	RLM 04	H413 MMP C113 090	BLACK	H12 MMP C33 047
RLM 74	H68 MMP C36 049	RLM 75	H69 MMP C37 050	RLM 76	H417 MMP C117 051	WHITE	H11 MMP C62 001

# C Fw 190A-5/U3, 1./SchG. 1, Orel, Soviet Union, July 1943

After I. Gruppe Schlachtgeschwader 1 re-equipment with Fw 190A-5/U3 and Fw 190F-3 aircraft, which was completed in May 1943, the whole unit was relocated to the Southern Sector of the Eastern Front to support the ground units in the combat against the Soviet tank units namely at just beginning battle of the Kursk Salient. Schlachtgeschwader 1 aircraft carried so called Infanteriesturmabzeichen (insignia of the infantry attack units) painted under the windshield, the color cannot be determined from the available photograph, it could have been either white or yellow. I./SchG.1 insignia – Panzerbär - was painted by mechanics on the engine cowling. The aircraft sported the Eastern Front markings i.e. yellow wing tips and yellow band surrounding the rear fuselage.

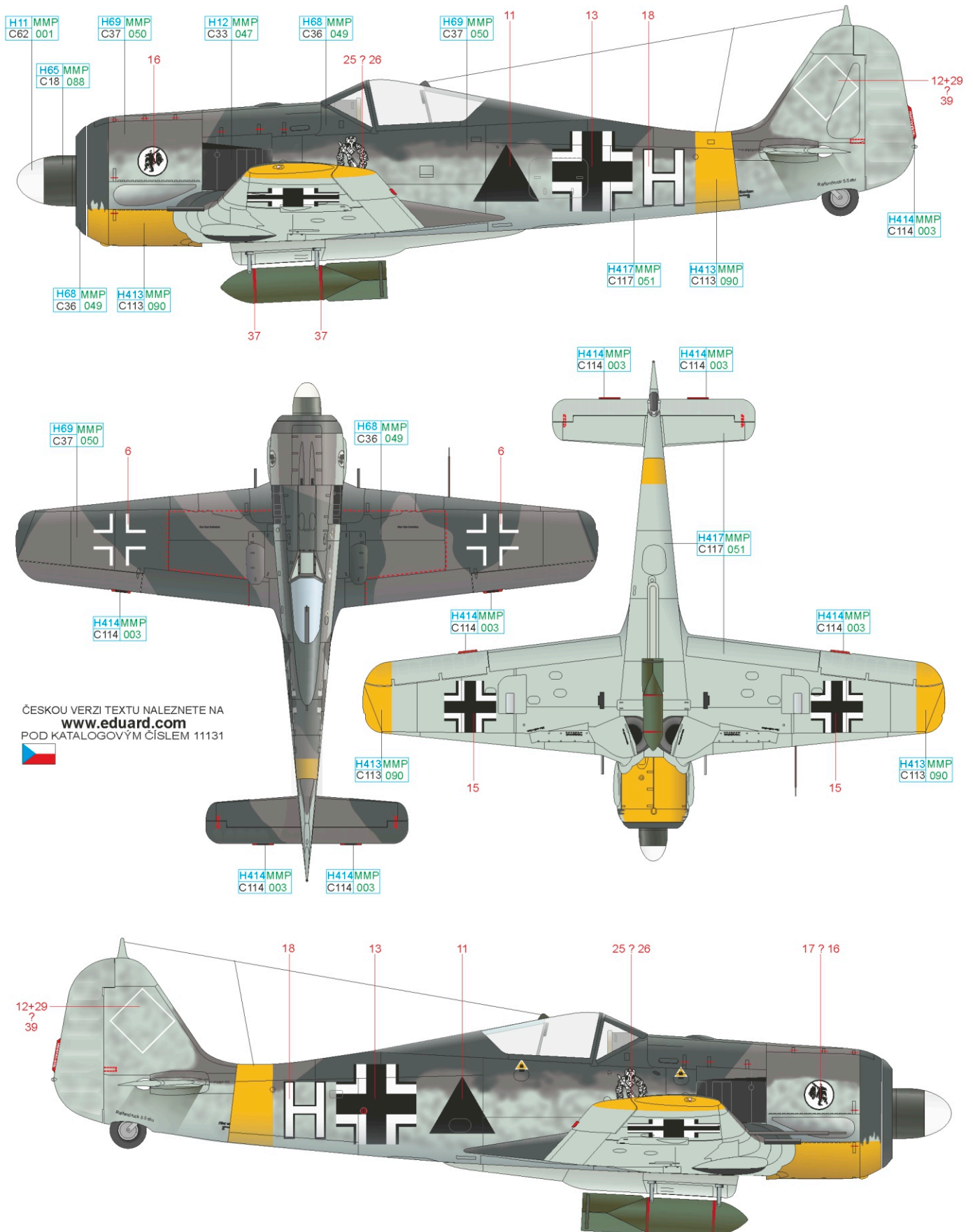

ČESKOU VERZI TEXTU NALEZNETE NA  
**www.eduard.com**  
 POD KATALOGOVÝM ČÍSLEM 11131



RLM 70	H65 MMP C18 088	RLM 23	H414MMP C114 003	RLM 04	H413MMP C113 090	BLACK	H12 MMP C33 047
RLM 74	H68 MMP C36 049	RLM 75	H69 MMP C37 050	RLM 76	H417MMP C117 051	WHITE	H11 MMP C62 001

# D Fw 190A-5/U8, W.Nr. 51353, flown by Oblt. Kurt Hevler, Stab IV./SKG 10, Cognac, France, June 1943

On June 4th, 1943, 18 attack Fw 190s from IV./SKG 10 headed with bombs attached towards the city of Eastbourne. The aircraft carrying Gruppenadjutant markings was hit by anti-aircraft fire, turned back home however the damaged engine could not supply the necessary power and the pilot attempted the emergency landing. That ended in the crash nearby the town of Normans Bay and Oblt. Hevler did not survive. According to the period description of the crashed aircraft yellow rudder and bottom of the engine cowling were over sprayed in the black irregular snakes.

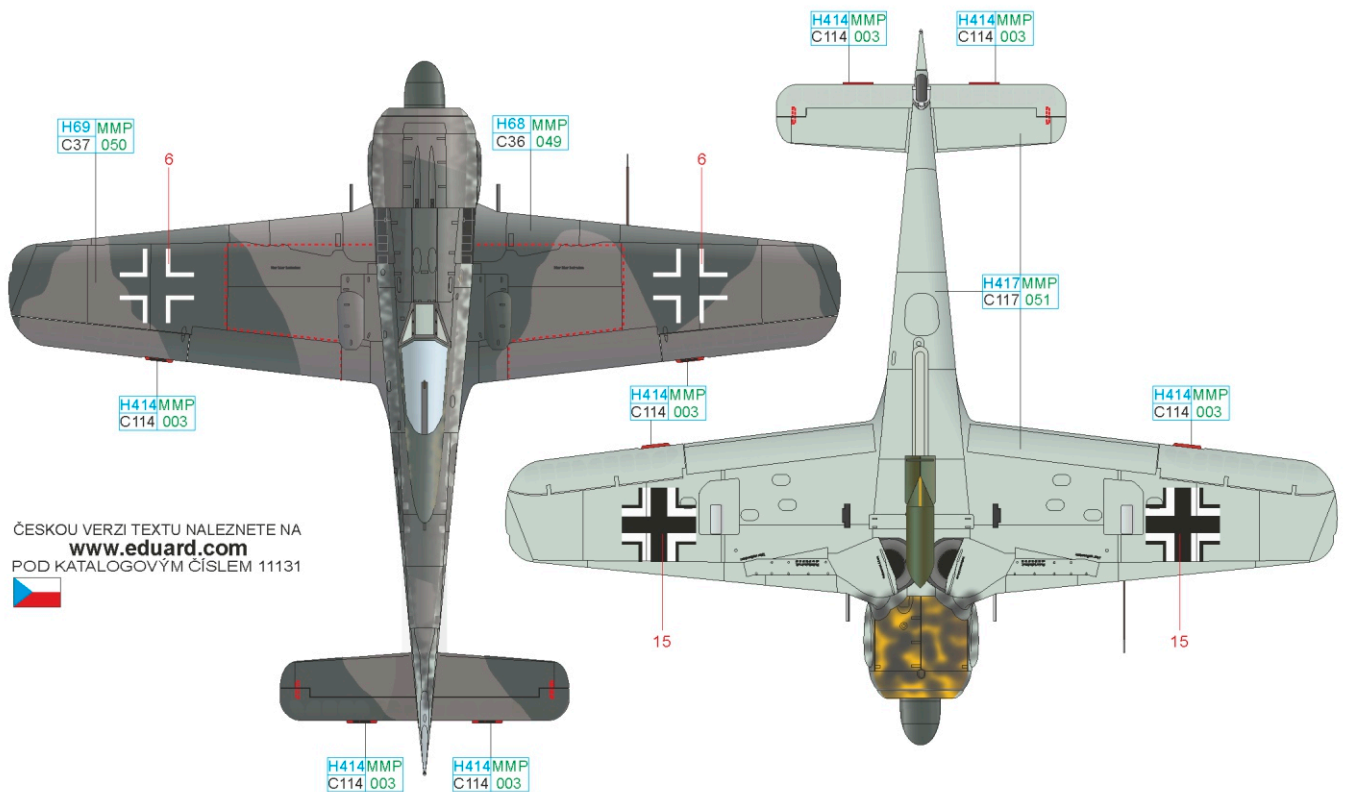
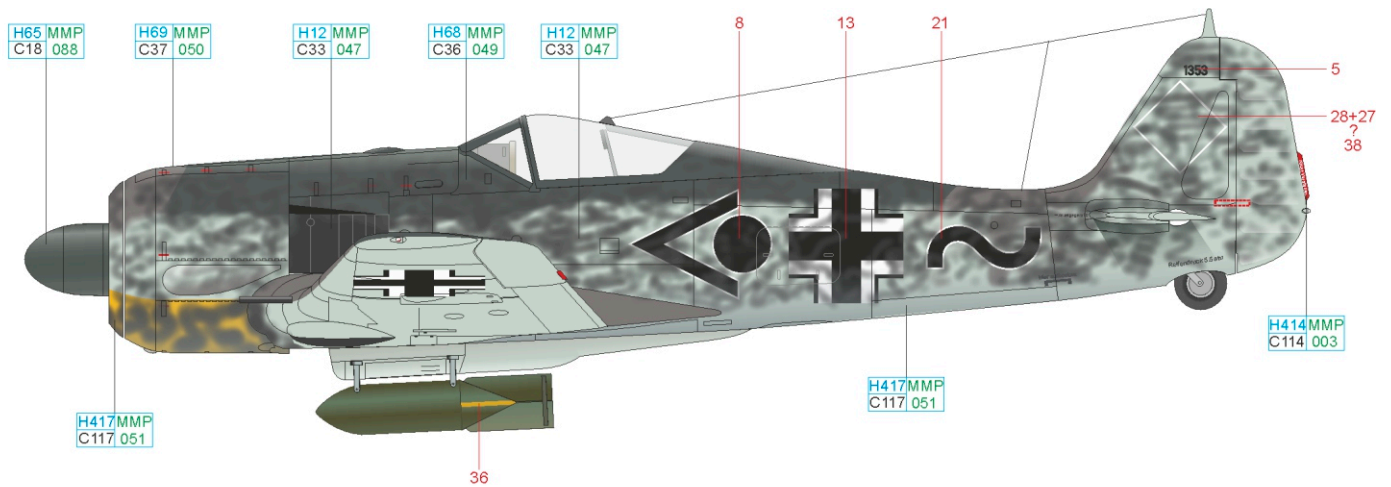

ČESKOU VERZI TEXTU NALEZNETE NA  
[www.eduard.com](http://www.eduard.com)  
POD KATALOGOVÝM ČÍSLEM 11131

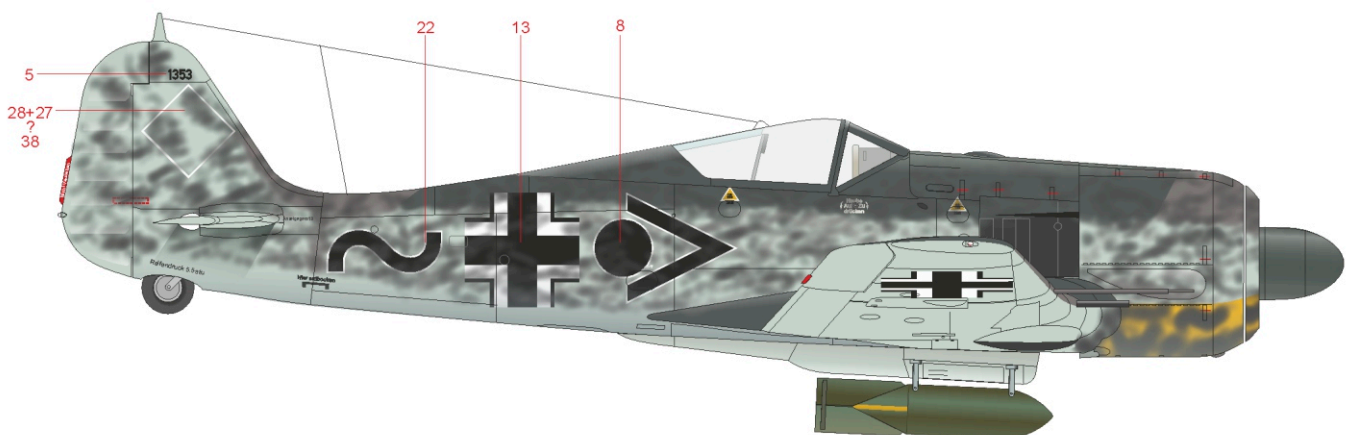

RLM 70	H65 MMP C18 088	RLM 23	H414 MMP C114 003	BLACK	H12 MMP C33 047
RLM 74	H68 MMP C36 049	RLM 75	H69 MMP C37 050	RLM 76	H417 MMP C117 051

# E Fw 190A-5/U3, W. Nr. 0150 1339, 9./SKG10, Gela – Ponte Olivo, Sicily, July 1943

Operation Husky (Sicily landing) commenced during the night of July 9th - 10th, 1943, when British forces landed on the East coast and the American divisions in the South of Sicily, in the vicinity of Licata and Gela towns. 1st US Infantry Division landed in the morning of July 13th, 1943 and captured the nearby airport Gela – Ponte Olivo where, besides other aircraft, this Fw 190A-5/U3 from 9. /SKG 10 was found. The aircraft, in otherwise standard camouflage, sported white propeller spinner and the fuselage in the front of the tail surfaces was surrounded in the white band-South Front aircraft marking. The factory marking R M B K on the wing lower surfaces was not deleted.

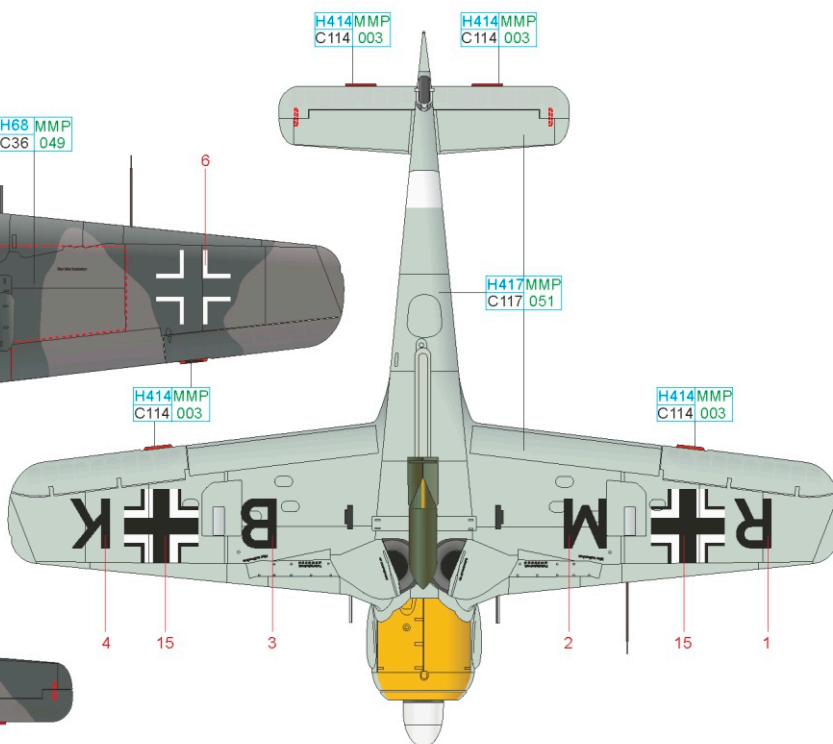
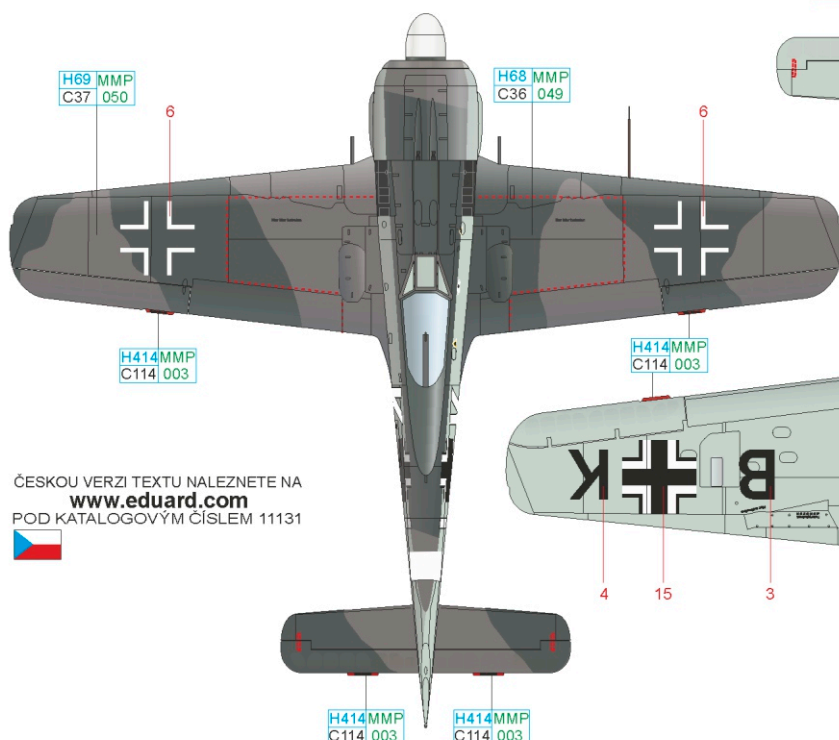
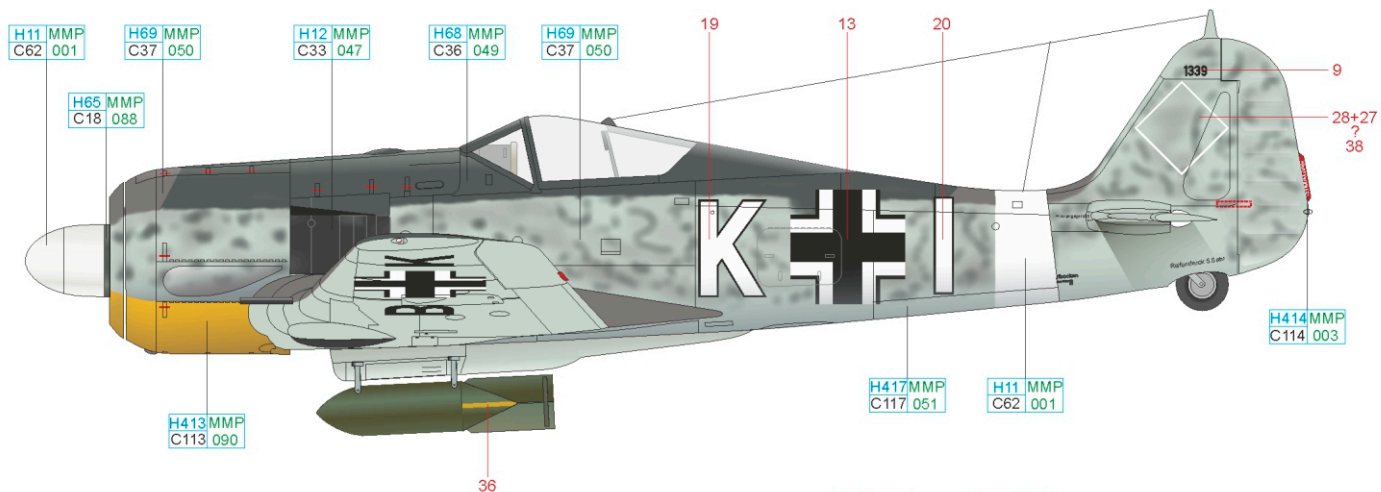

ČESKOU VERZI TEXTU NALEZNETE NA  
[www.eduard.com](http://www.eduard.com)  
POD KATALOGOVÝM ČÍSLEM 11131

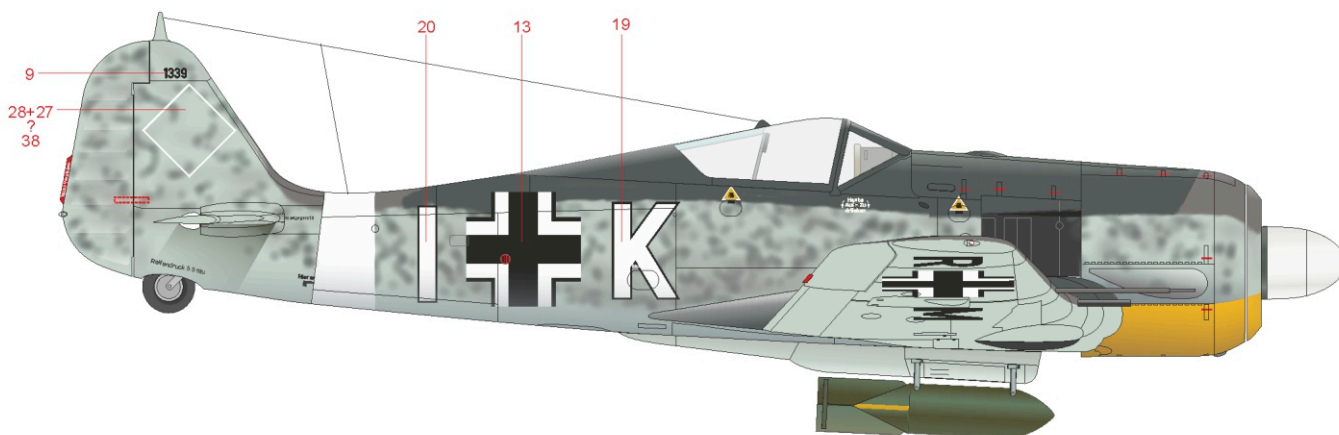

RLM 70	H65 MMP C18 088	RLM 23	H414MMP C114 003	RLM 04	H413MMP C113 090	BLACK	H12 MMP C33 047
RLM 74	H68 MMP C36 049	RLM 75	H69 MMP C37 050	RLM 76	H417MMP C117 051	WHITE	H11 MMP C62 001

