

Revell F-15 EAGLE CONFRONTATION AT MACH II

KIT 4764

REVELL, INC. Des Plaines, IL Copyright © 1987 All rights reserved. Made in U.S.A.

4764-4200

F-15 EAGLE

F-15 EAGLE SPECIFICATIONS

Type: Single-seat all weather air superiority fighter

Dimensions:

Length: 63' 9" (19.4m)

Wingspan: 42' 10" (13.1m)

Height: 18' 6" (5.6m)

Powerplant: Two Pratt & Whitney F100 turbofan engines

Performance: Max. speed mach 2.5 +
Service ceiling 63,000' (19,200m)

Armament: One 20mm M-61 cannon plus four AIM-9 sidewinder air-to-air missiles and four AIM-7 Sparrow air-to-air missiles

The Soviet MiG-25 "Foxbat" and the USAF F-15 Eagle are two of the most formidable combat planes in the skies today. Although they are very similar in appearance, they actually serve two very different purposes. The Russian plane is more suitable in high-speed intercept or recon roles. It was originally designed to intercept the tri-sonic B-70 bomber, and is limited to high-speed intercept, using its missiles for destruction. In close-range combat, the Foxbat is virtually useless because of its great weight and lack of maneuverability and guns.

On the other hand, the McDonnell F-15 Eagle was developed specifically for close-up dog fighting, using its two powerful engines for vertical climbs and its 20mm rotary cannon and mis-

siles for the kill. Ideally suited as a dog fighter, the F-15 carries up to eight air to air missiles in addition to the cannon.

What might happen if the two planes met in combat? The MiG would probably fire its missiles from long range, then use its superior Mach 3.2 speed to escape. The F-15 would try to approach as close as practical, using its homing missiles for the attack. However, due to the Foxbat's superior speed, a successful attack would have to be a surprise encounter. Another important factor in the outcome would be pilot experience.

The markings on the F-15 model in this kit are for an Eagle of the 33rd TFW, based at Elgin AFB, Florida.

ENGLISH: ASSEMBLY DRAWINGS SHOULD BE REVIEWED BEFORE PROCEEDING WITH CONSTRUCTION. A NUMBER IDENTIFIES EACH PLASTIC PART FOR YOUR CONVENIENCE. PAINT SMALL PARTS ON RUNNER BEFORE REMOVING. ALLOW PAINT TO DRY THOROUGHLY BEFORE CONTINUING ASSEMBLY OF KIT. SCRAPE CHROME OR PAINT AT AREA TO BE GLUED. WASH PLASTIC IN MILD DETERGENT SOLUTION. RINSE AND LET DRY FOR BETTER PAINT AND DECAL ADHESION.

FRANÇAIS: ÉTUDIEZ LES SCHÉMAS DE MONTAGE AVANT DE COMMENCER LA CONSTRUCTION. UN NUMÉRO IDENTIFIE CHAQUE PIÈCE EN PLASTIQUE POUR PLUS DE FACILITÉ. PEIGNEZ LES PETITES PIÈCES SUR LE COUREUR AVANT DE LES ENLEVER. LAISSEZ SÉCHER LA PEINTURE AVANT DE CONTINUER LE MONTAGE DU KIT. GRATTEZ LE CHROME OU LA PEINTURE DANS LES ZONES QUI DOI-

VENT ÊTRE COLLÉES. PUIS, LAVEZ LE PLASTIQUE DANS UNE SOLUTION FAIBLE DE DÉTERGENT. RINCEZ ET LAISSEZ SÉCHER À L'AIR POUR ASSURER UNE MEILLEURE ADHÉRENCE DE LA PEINTURE ET DES DÉCALCOMANIES.

ESPAÑOL: ESTUDIE LOS PLANOS DE MONTAJE ANTES DE INICIAR LA CONSTRUCCION. PARA FACILITAR LAS COSAS, CADA PIEZA DE PLASTICO LLEVA UN NUMERO DE IDENTIFICACION. PINTE LAS PIECITAS DEL CORREDOR ANTES DE QUITARLAS. PERMITA QUE LA PINTURA SE SEQUE BIEN ANTES DE PROSEGUIR EL MONTAJE DEL EQUIPO. RASPE EL CROMO O LA PINTURA DE LAS ZONAS QUE SE VAYAN A ENCOLAR LAVE EL PLASTICO EN UNA SOLUCION LIGERA DE DETERGENTE, ENJUAGUELO Y DEJELO SECAR AL AIRE PARA OBTENER UNA MEJOR ADHERENCIA DE LA PINTURA Y LAS CALCOMANIAS.



GLUE
COLLE
COLA



NO GLUE REQUIRED
PAS BESOIN DE COLLE
NO SE REQUIERE COLA



DO IT THIS MANY TIMES
LE FAIRE CE NOMBRE DE FOIS
HAGALO TODAS ESTAS VECES



OPTIONAL
OPTIONNEL
OPCIONAL

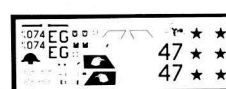

APPLY DECALS
COLLEZ LES DÉCALCOMANIES
PEGUE LAS CALCOMANIAS



SHOWN ASSEMBLED
PRÉSENTE ASSEMBLÉ
SE PRESENTA MONTADO



CLEAR
TRANSPARENT
TRANSPARENTE



LIGHT GRAY
GRIS CLAIR
GRIS CLARO

A <	OLIVE GREEN	VERT OLIVE	VERDE OLIVA
B <	LIGHT GRAY FS 36375	GRIS CLAIR FS 36375	GRIS CLARO FS 36375
C <	DARK GRAY FS 36320	GRIS FONCE FS 36320	GRIS OSCURO FS 36320
D <	WHITE	BLANC	BLANCO
E <	MATT BLACK	NOIR MAT	NEGRO MATE

F <	HULL RED	ROUGE COQUE	ROJO CASCO
G <	METALLIC GRAY	GRIS METALLISE	GRIS METALICO
H <	SILVER	ARGENT	PLATA
I <	TAN	BRUN	TOSTADO
J <	GLOSS BLACK	NOIR VERNIS	NEGRO BRILLANTE

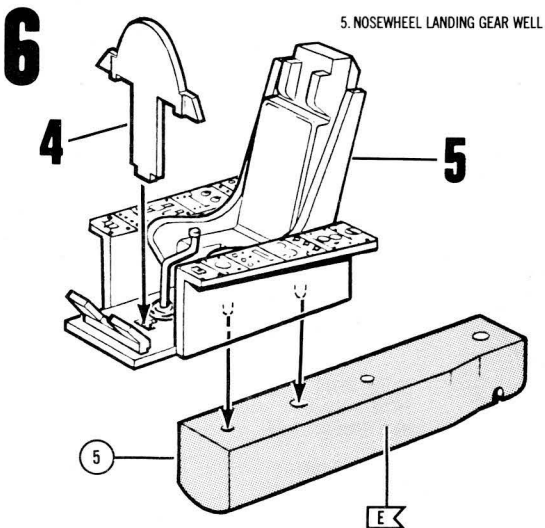
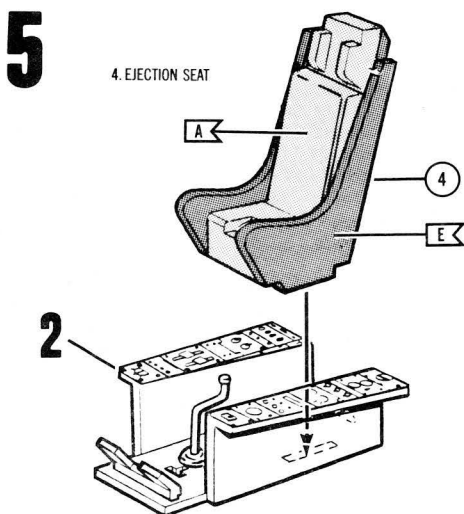
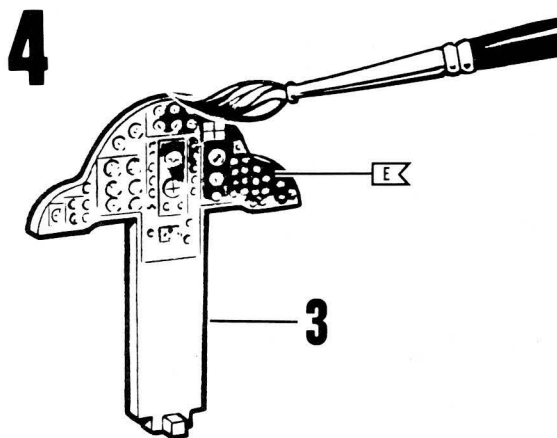
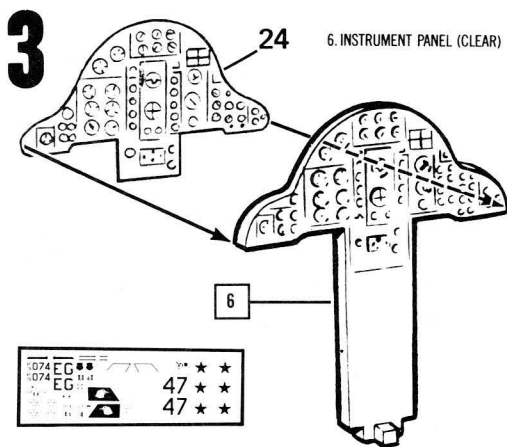
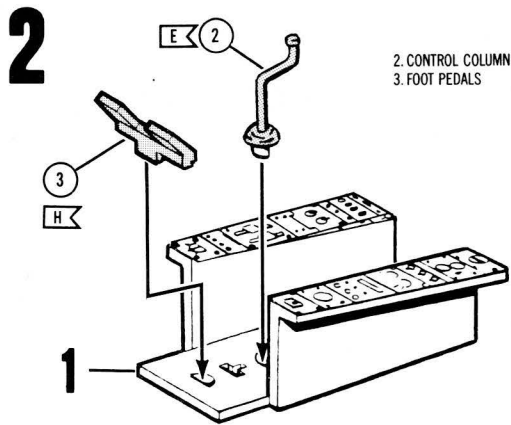
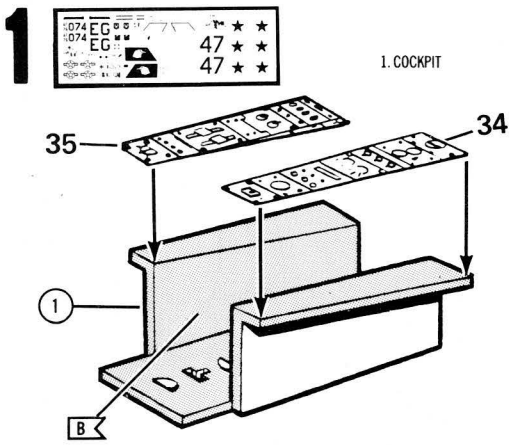

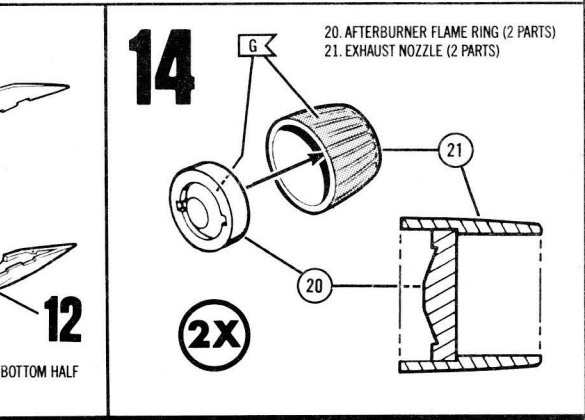
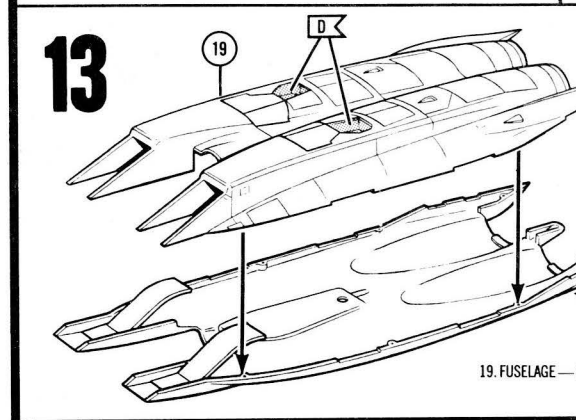
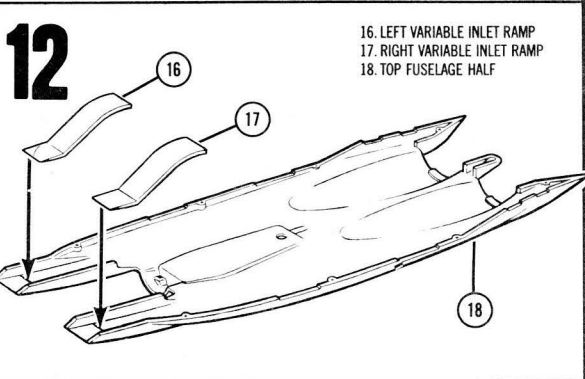
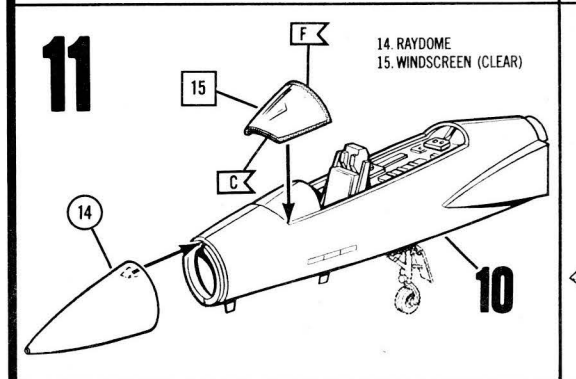
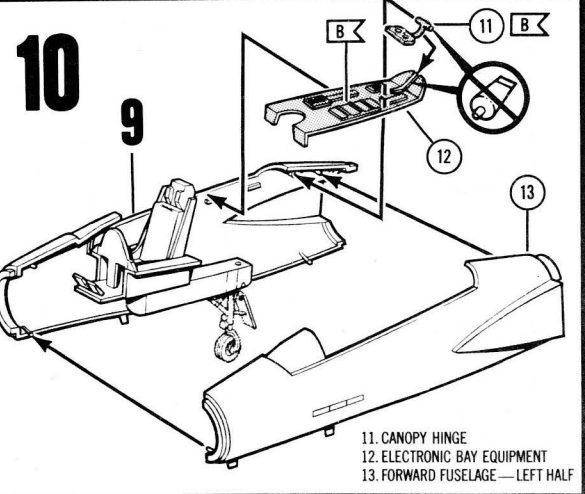
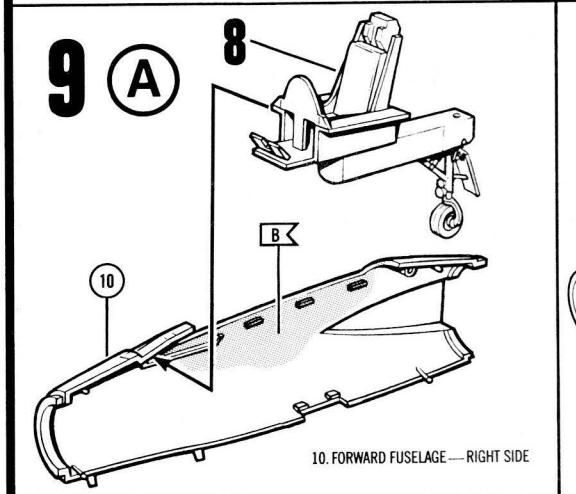
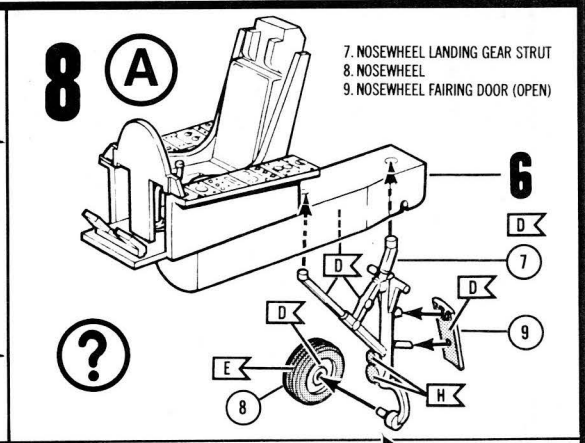
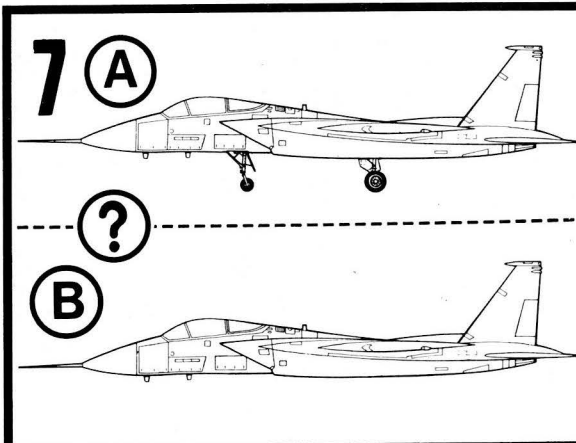

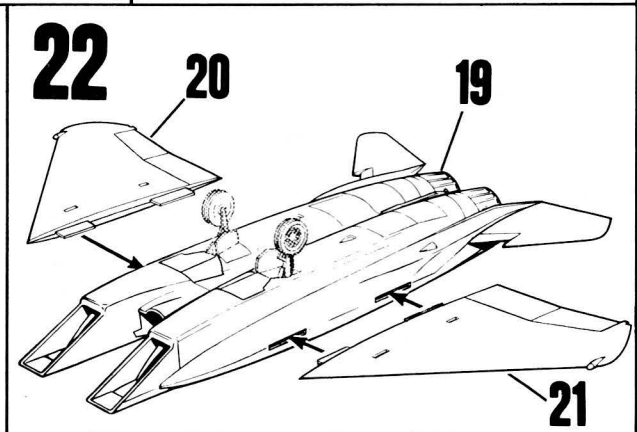
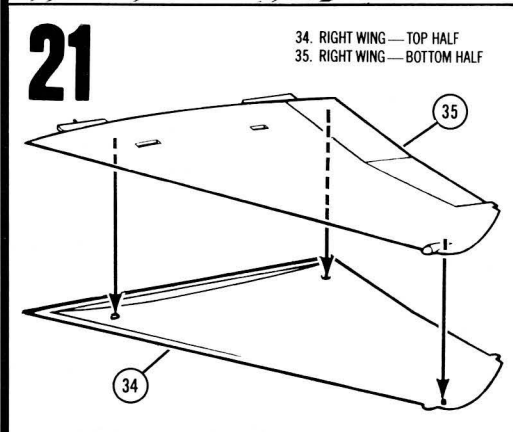
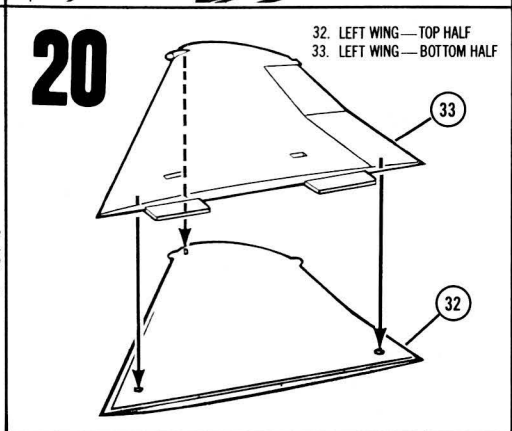
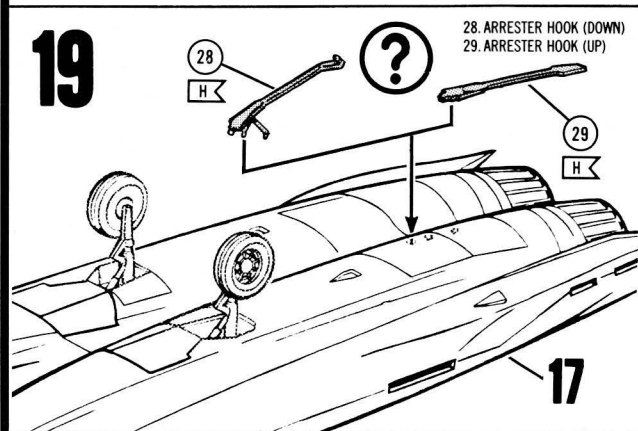
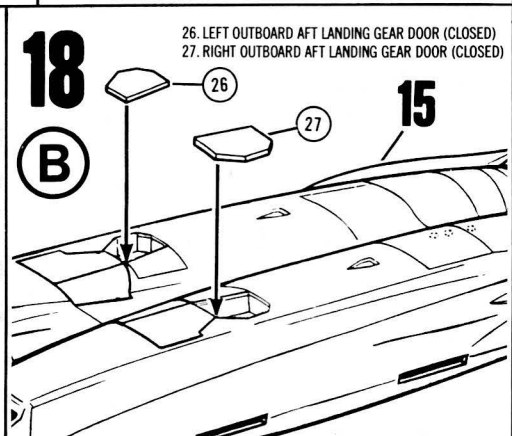
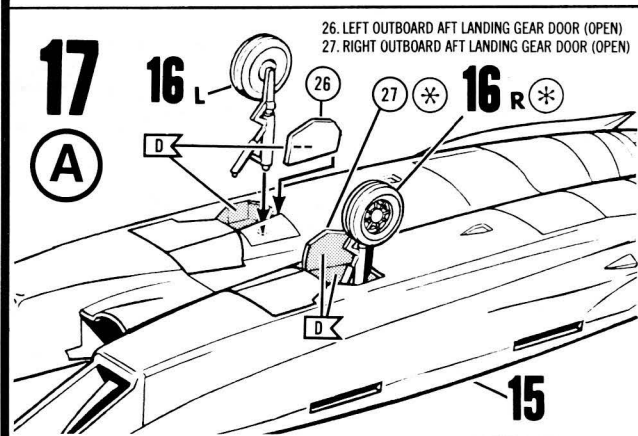
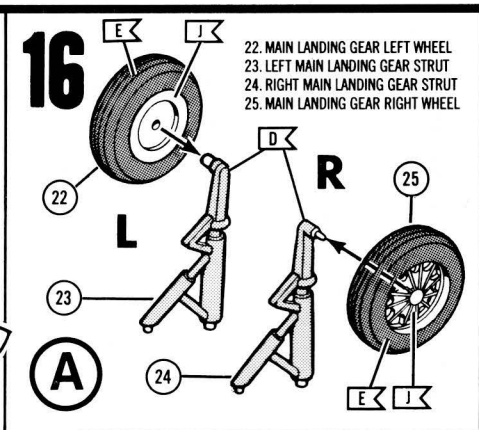
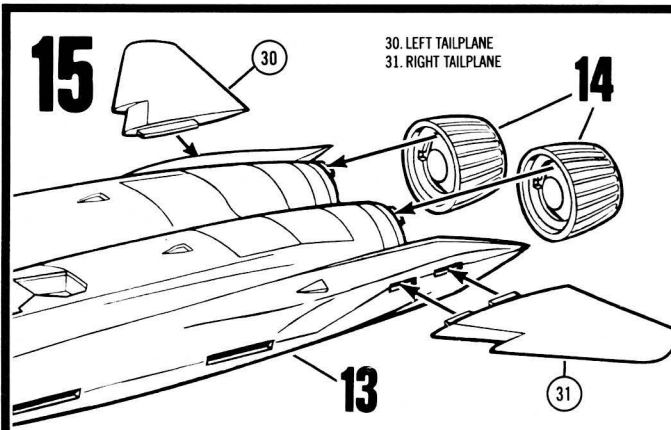

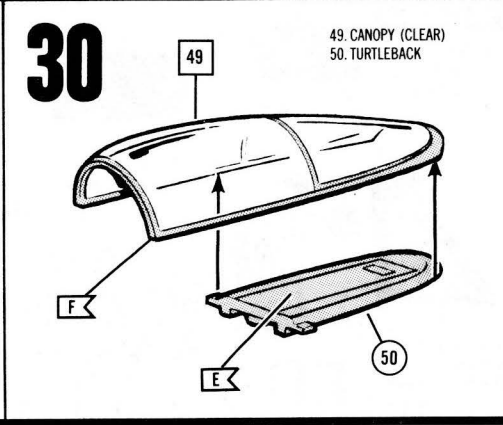
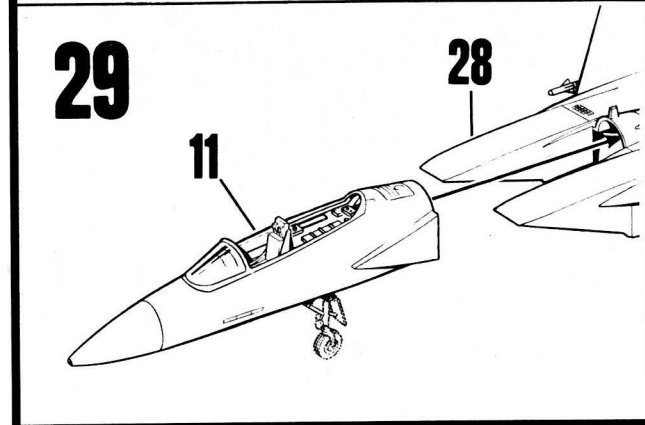
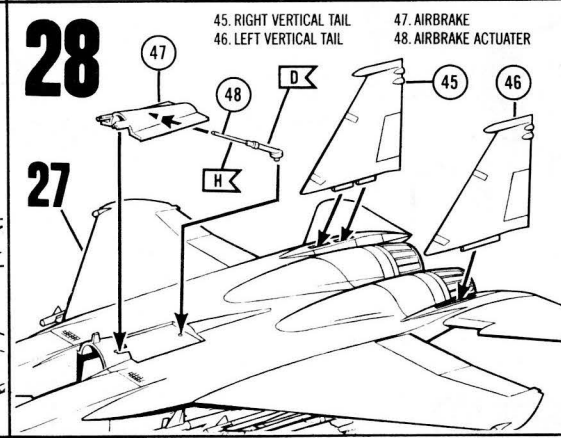
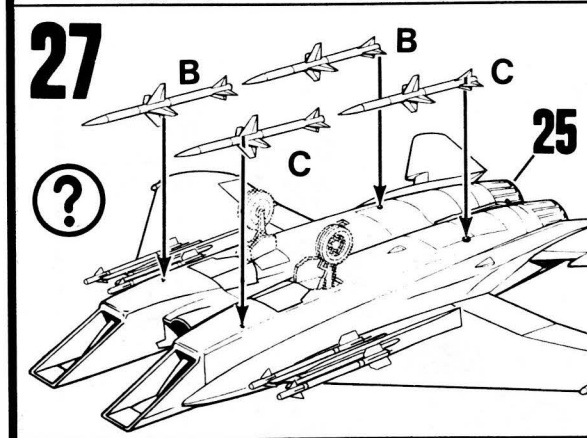
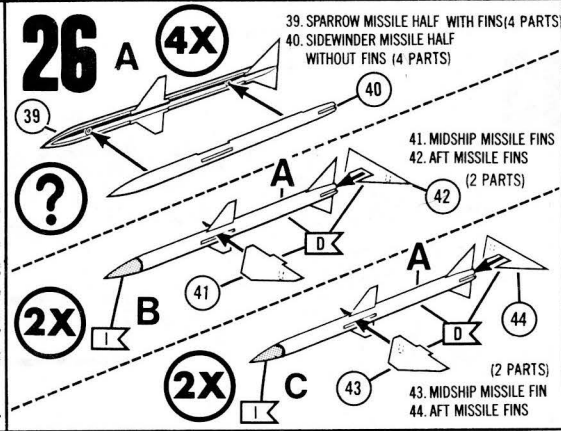
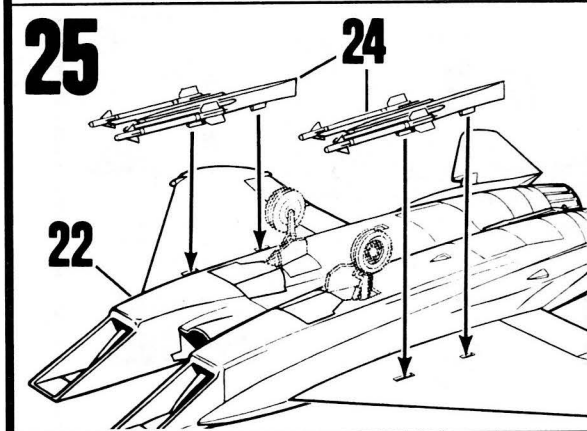
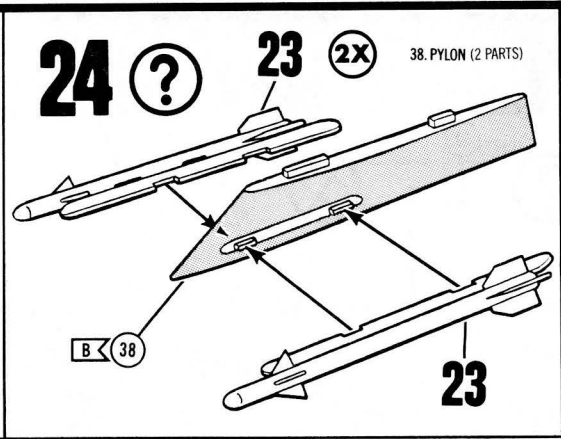
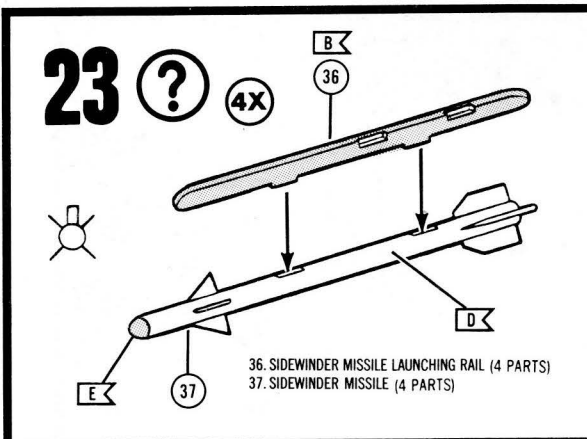

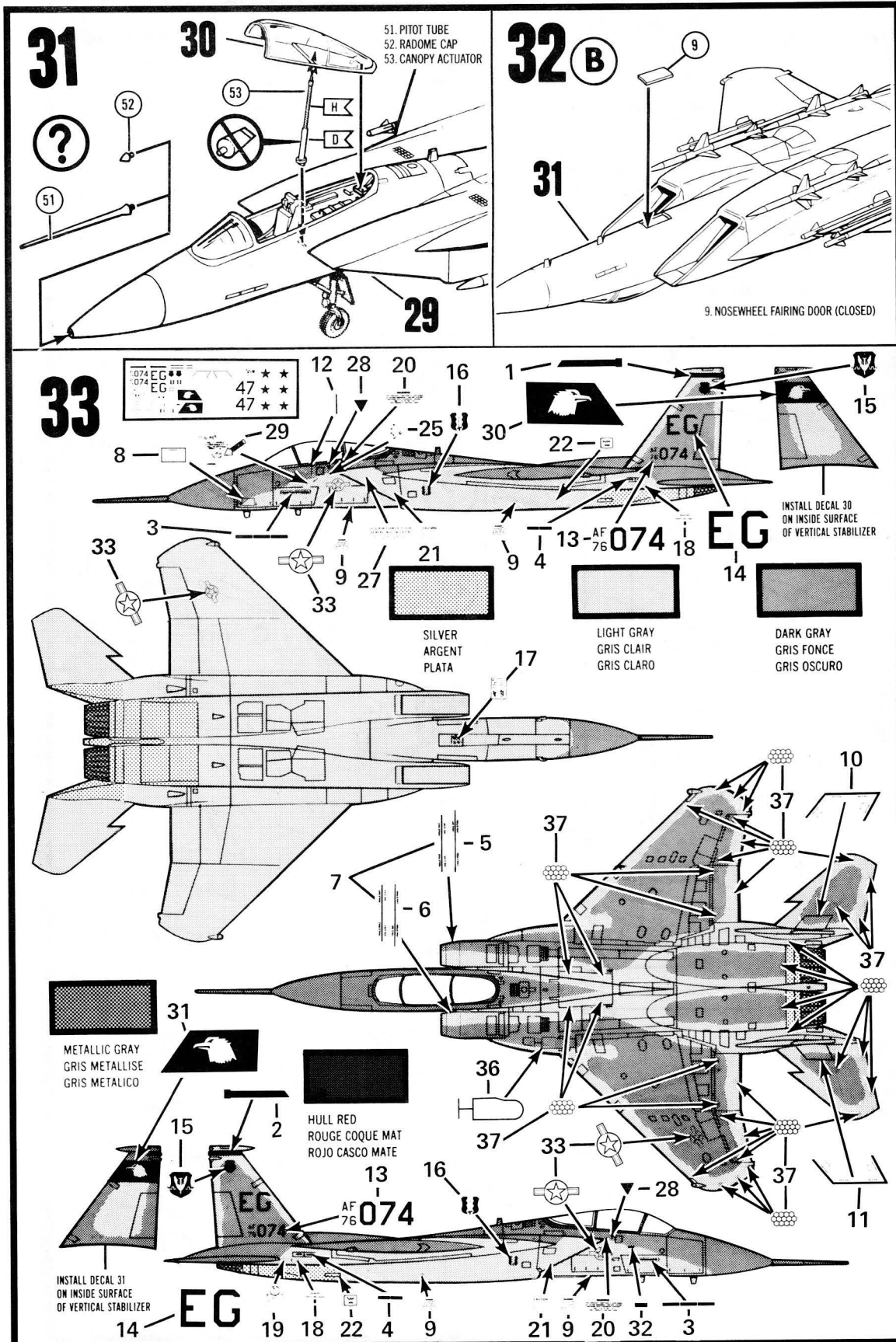



MIG-25 FOXBAT CONFRONTATION AT MACH II

KIT 4764

REVELL, INC. Des Plaines, IL Copyright © 1987 All rights reserved. Made in U.S.A.

4764-4200

MIG-25 FOXBAT

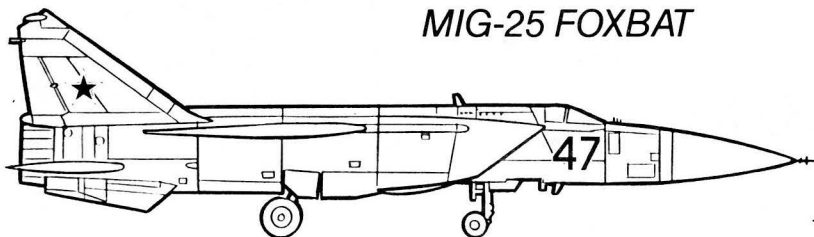

MIG-25 FOXBAT SPECIFICATIONS

Type: Single seat all-weather interceptor

Dimensions:

Length: 73' 2" (22.3m)

Wingspan: 46' (14.0m)

Height: 18' 6" (5.63m)

Powerplant: Two Tumansky R-31 turbojet engines

Performance: Max. speed mach 2.8
Service ceiling 75,000' (23,000m)

Armament: Four underwing pylons with four AA-6 air-to-air missiles

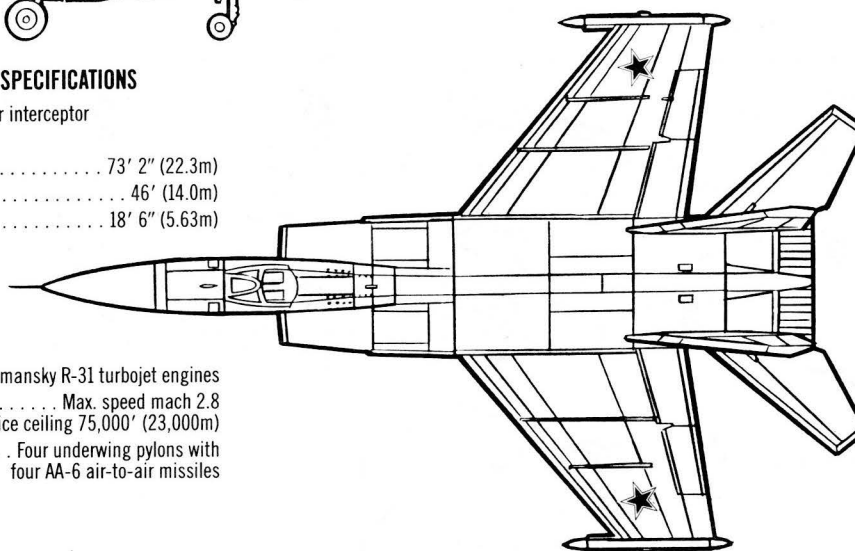

ENGLISH: ASSEMBLY DRAWINGS SHOULD BE REVIEWED BEFORE PROCEEDING WITH CONSTRUCTION. A NUMBER IDENTIFIES EACH PLASTIC PART FOR YOUR CONVENIENCE. PAINT SMALL PARTS ON RUNNER BEFORE REMOVING. ALLOW PAINT TO DRY THOROUGHLY BEFORE CONTINUING ASSEMBLY OF KIT. SCRAPE CHROME OR PAINT AT AREA TO BE GLUED. WASH PLASTIC IN MILD DETERGENT SOLUTION. RINSE AND LET DRY FOR BETTER PAINT AND DECAL ADHESION.

FRANÇAIS: ÉTUDIEZ LES SCHÉMAS DE MONTAGE AVANT DE COMMENCER LA CONSTRUCTION. UN NUMÉRO IDENTIFIE CHAQUE PIÈCE EN PLASTIQUE POUR PLUS DE FACILITÉ. PEIGNEZ LES PETITES PIÈCES SUR LE COUREUR AVANT DE LES ENLEVER. LAISSEZ SÉCHER LA PEINTURE AVANT DE CONTINUER LE MONTAGE DU KIT. GRATTEZ LE CHROME OU LA PEINTURE DANS LES ZONES QUI DOI-

VENT ÊTRE COLLÉES. PUIS, LAVEZ LE PLASTIQUE DANS UNE SOLUTION FAIBLE DE DÉTERGENT, RINCEZ ET LAISSEZ SÉCHER À L'AIR POUR ASSURER UNE MEILLEURE ADHÉRENCE DE LA PEINTURE ET DES DÉCALCOMANIES.

ESPAÑOL: ESTUDIE LOS PLANOS DE MONTAJE ANTES DE INICIAR LA CONSTRUCCION. PARA FACILITAR LAS COSAS, CADA PIEZA DE PLASTICO LLEVA UN NUMERO DE IDENTIFICACION. PINTA LAS PIECITAS DEL CORREDOR ANTES DE QUITARLAS. PERMITA QUE LA PINTURA SE SEQUE BIEN ANTES DE PROSEGUIR EL MONTAJE DEL EQUIPO. RASPE EL CROMO O LA PINTURA DE LAS ZONAS QUE SE VAYAN A ENCOLAR. LAVE EL PLASTICO EN UNA SOLUCION LIGERA DE DETERGENTE. ENJUAGUELO Y DEJELO SECAR AL AIRE PARA OBTENER UNA MEJOR ADHERENCIA DE LA PINTURA Y LAS CALCOMANIAS.



GLUE
COLLE
COLA



NO GLUE REQUIRED
PAS BESOIN DE COLLE
NO SE REQUIERE COLA



DO IT THIS MANY TIMES
LE FAIRE CE NOMBRE DE FOIS
HAGALO TODAS ESTAS VECES



OPTIONAL
OPTIONNEL
OPCIONAL

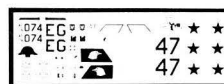

APPLY DECALS
COLLEZ LES DÉCALCOMANIES
PEGUE LAS CALCOMANIAS



SHOWN ASSEMBLED
PRÉSENTÉ ASSEMBLÉ
SE PRESENTA MONTADO



CLEAR
TRANSPARENT
TRANSPARENTE



LIGHT GRAY
GRIS CLAIR
GRIS CLARO

A	RED	ROUGE	ROJO
B	WHITE	BLANC	BLANCO
C	GUN METAL	MÉTAL D'ARMES	GRIS REVOLVER
D	MATT BLACK	NOIR MAT	NEGRO MATE
E	MATT LIGHT GREY	GRIS CLAIR MAT	GRIS PALIDO MATE

F	OLIVE GREEN	VERT OLIVE	VERDE OLIVA
G	SILVER	ARGENT	PLATA
H	DARK GRAY	GRIS FONCE	GRIS OSCURO
I	MATT DARK GREEN GRAY	VERT-DE-GRIS FONCE MAT	VERDE GRISOSO OSCURO MATE

1

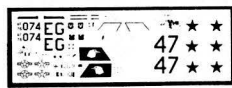

49. INSTRUMENT PANEL

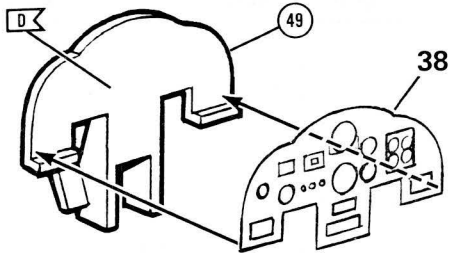

2

4. EJECTION SEAT
5. COCKPIT
6. CONTROL COLUMN

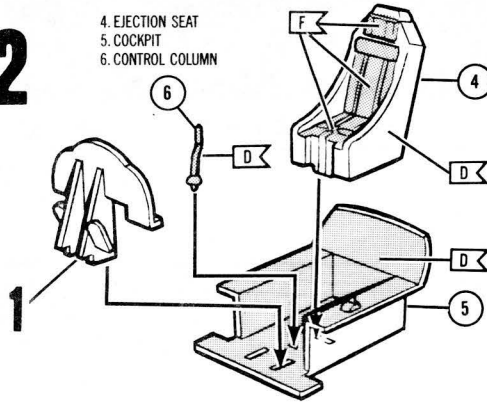

3

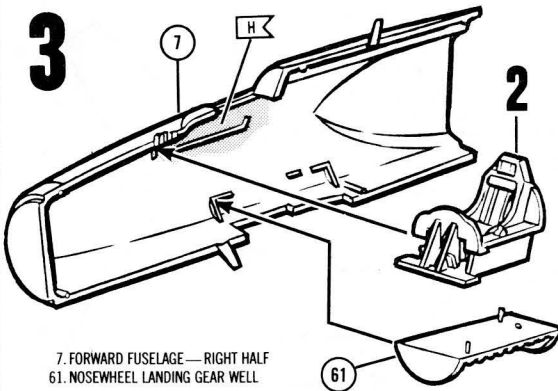

7. FORWARD FUSELAGE — RIGHT HALF
61. NOSEWHEEL LANDING GEAR WELL

4

8. FORWARD FUSELAGE — LEFT HALF
11. INTAKE INBOARD SIDEWALL — LEFT
12. INTAKE INBOARD SIDEWALL — RIGHT

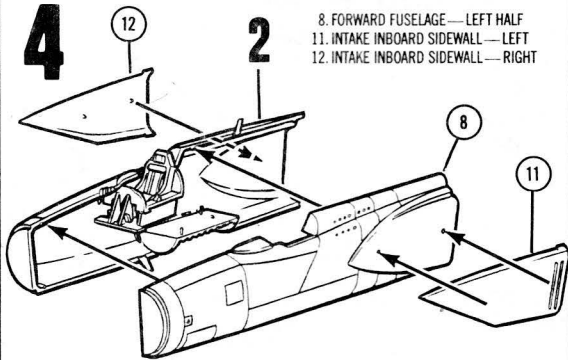

5

2. LEFT RADOME HALF
3. PITOT TUBE
60. RIGHT RADOME HALF

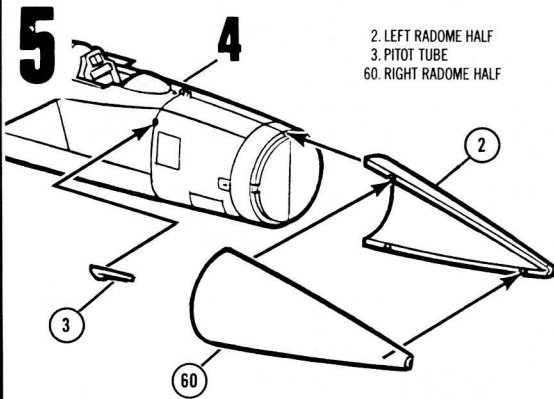

6

20. AFT FUSELAGE — TOP HALF
21. AFT FUSELAGE — BOTTOM HALF

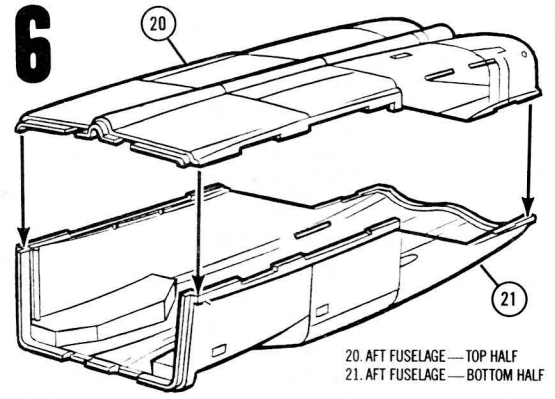

7

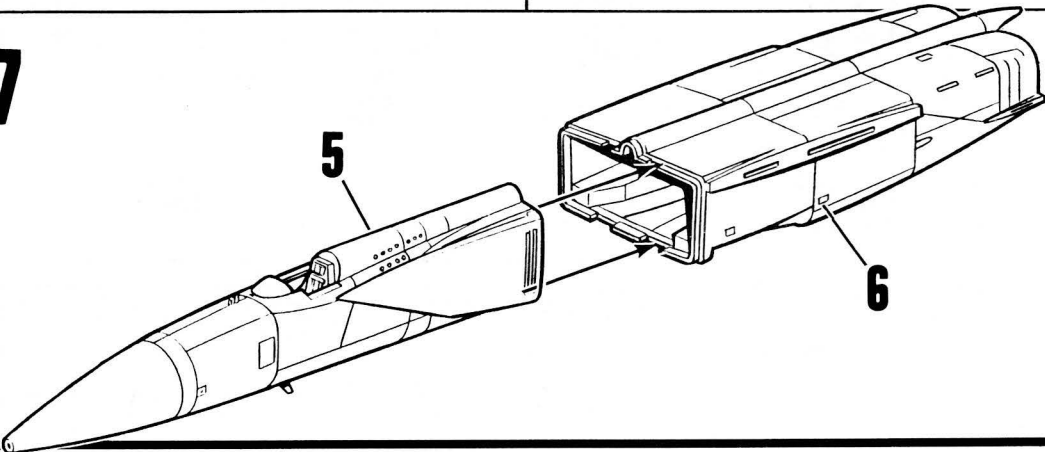

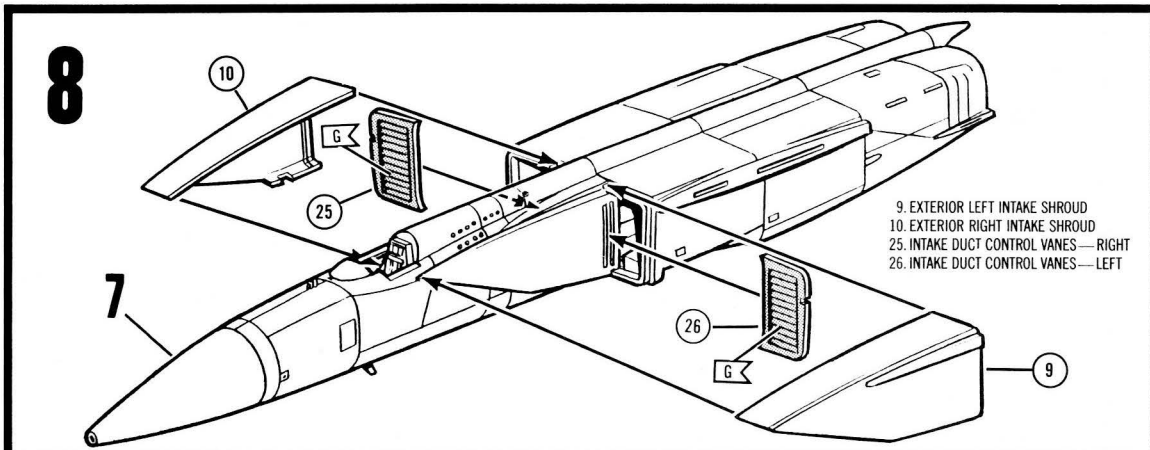

9. EXTERIOR LEFT INTAKE SHROUD
 10. EXTERIOR RIGHT INTAKE SHROUD
 25. INTAKE DUCT CONTROL VANES—RIGHT
 26. INTAKE DUCT CONTROL VANES—LEFT

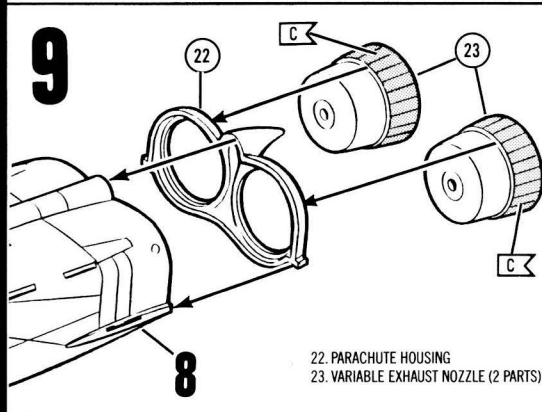

22. PARACHUTE HOUSING
 23. VARIABLE EXHAUST NOZZLE (2 PARTS)

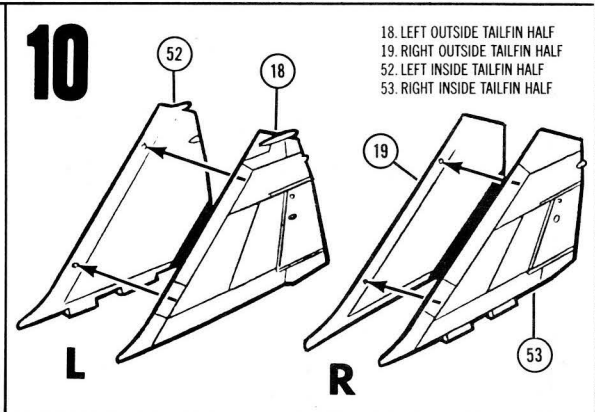

18. LEFT OUTSIDE TAILFIN HALF
 19. RIGHT OUTSIDE TAILFIN HALF
 52. LEFT INSIDE TAILFIN HALF
 53. RIGHT INSIDE TAILFIN HALF

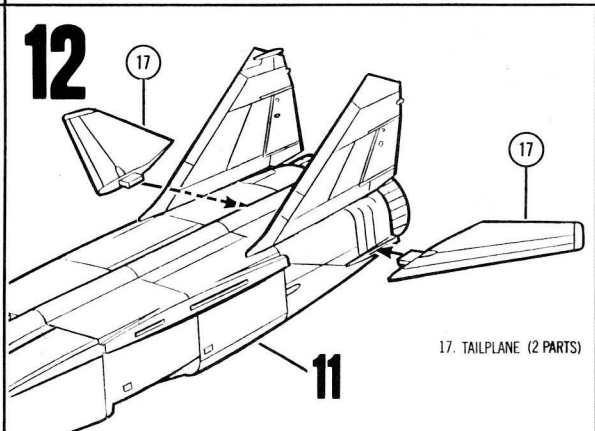
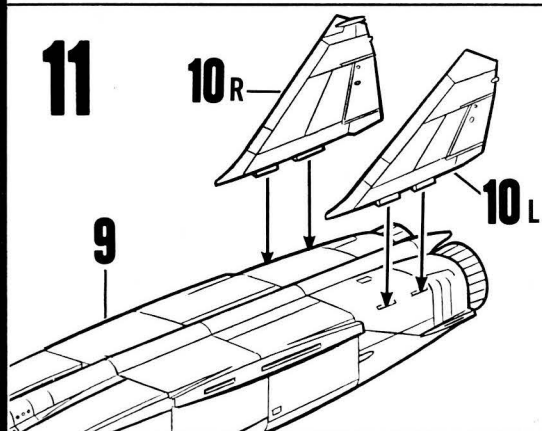

17. TAILPLANE (2 PARTS)

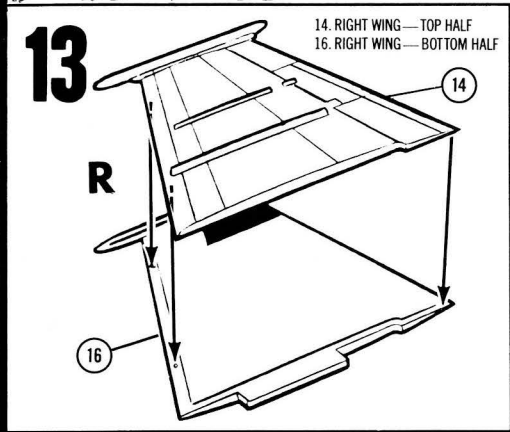

14. RIGHT WING—TOP HALF
 16. RIGHT WING—BOTTOM HALF

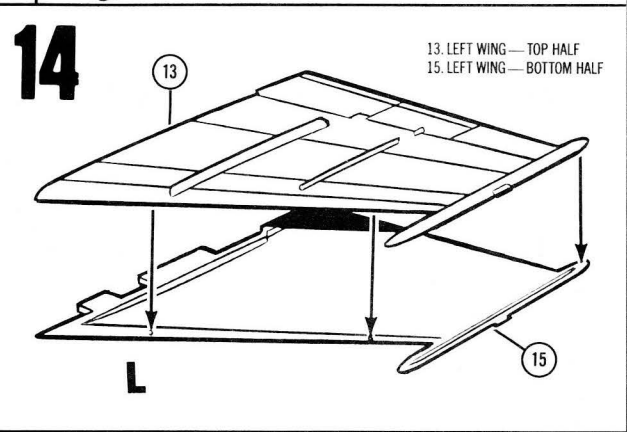

13. LEFT WING—TOP HALF
 15. LEFT WING—BOTTOM HALF

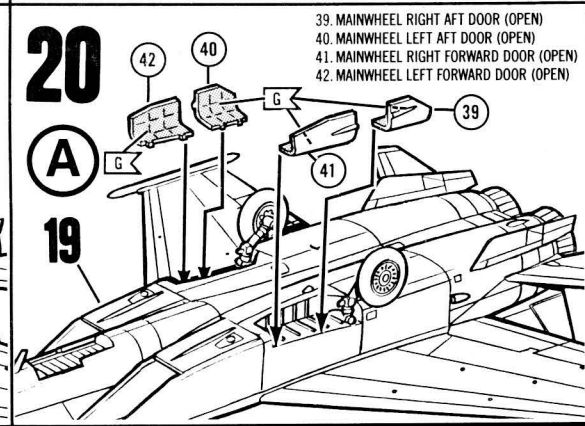
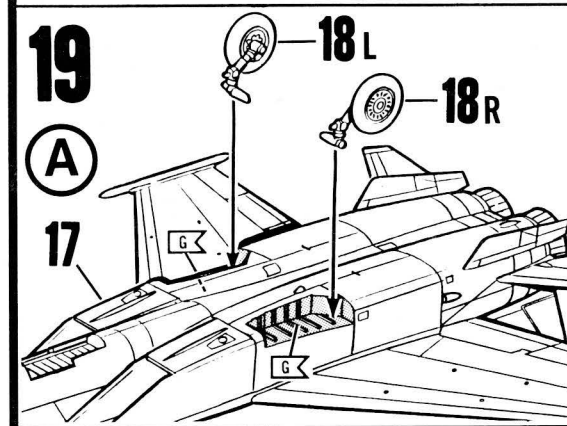
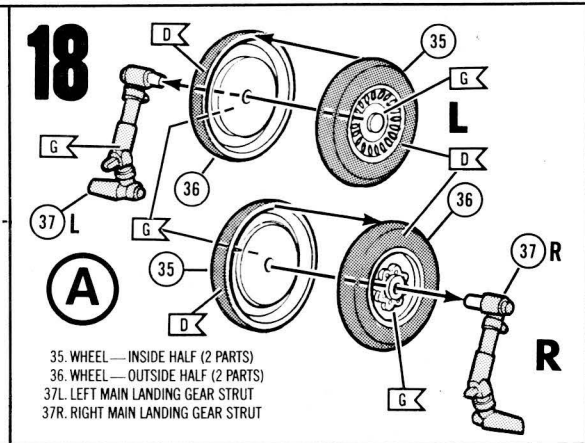
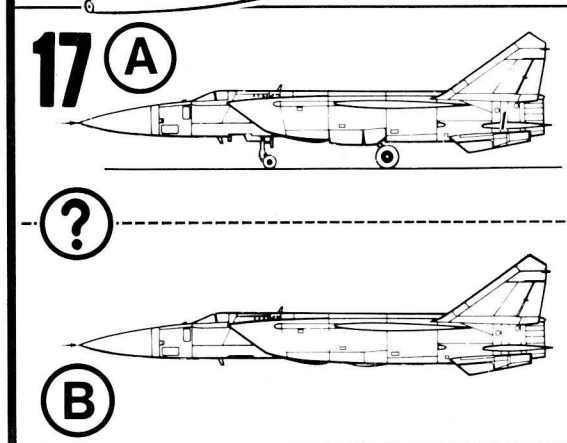
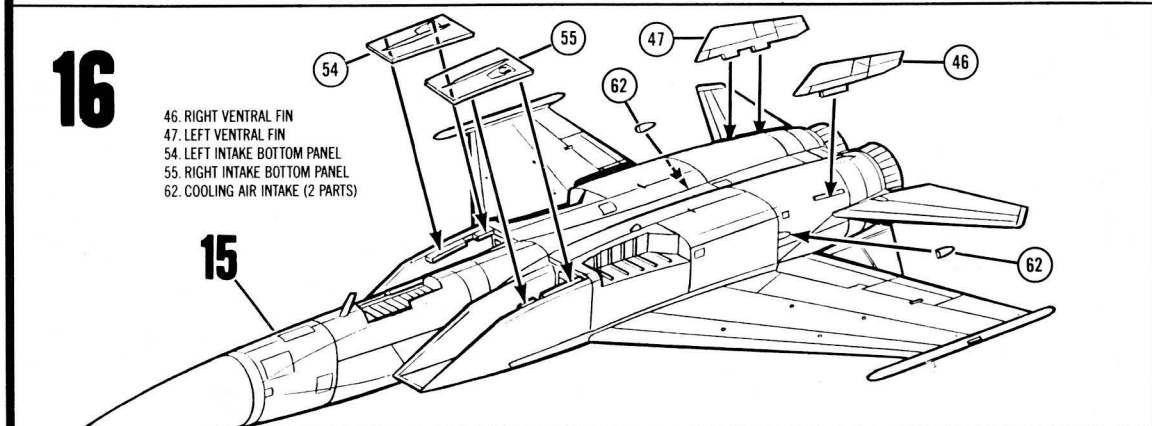
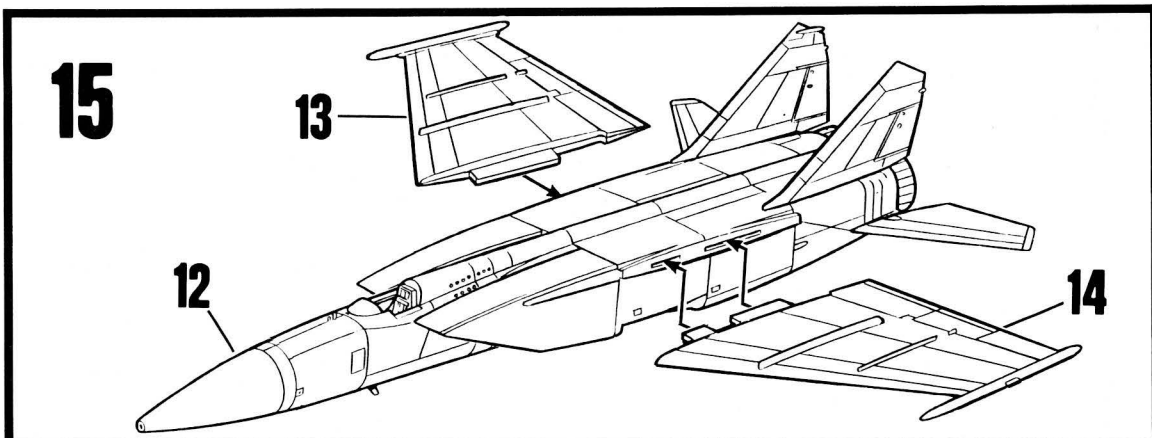

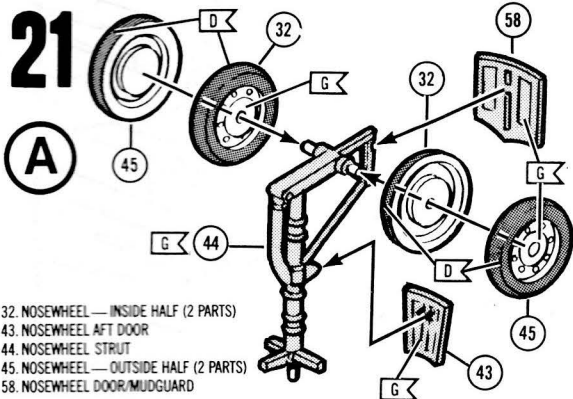

32. NOSEWHEEL — INSIDE HALF (2 PARTS)
 43. NOSEWHEEL AFT DOOR
 44. NOSEWHEEL STRUT
 45. NOSEWHEEL — OUTSIDE HALF (2 PARTS)
 58. NOSEWHEEL DOOR/MUDGUARD

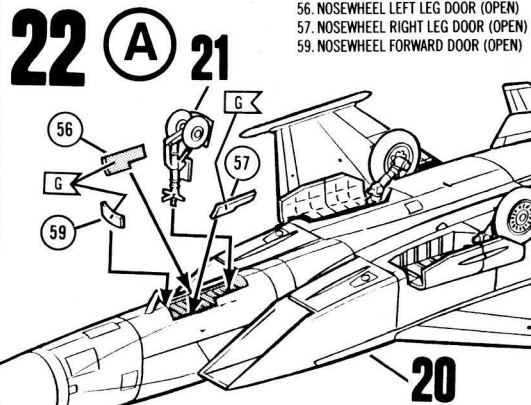

56. NOSEWHEEL LEFT LEG DOOR (OPEN)
 57. NOSEWHEEL RIGHT LEG DOOR (OPEN)
 59. NOSEWHEEL FORWARD DOOR (OPEN)

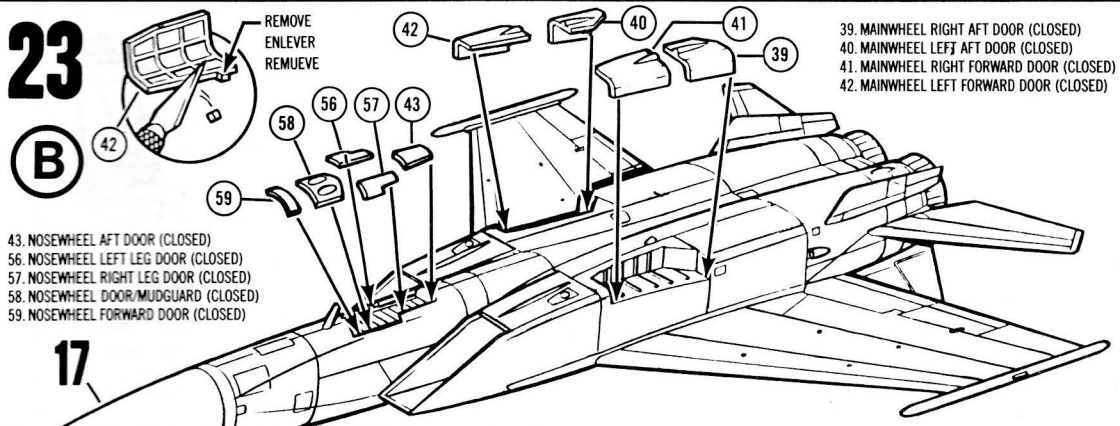

39. MAINWHEEL RIGHT AFT DOOR (CLOSED)
 40. MAINWHEEL LEFT AFT DOOR (CLOSED)
 41. MAINWHEEL RIGHT FORWARD DOOR (CLOSED)
 42. MAINWHEEL LEFT FORWARD DOOR (CLOSED)
43. NOSEWHEEL AFT DOOR (CLOSED)
 56. NOSEWHEEL LEFT LEG DOOR (CLOSED)
 57. NOSEWHEEL RIGHT LEG DOOR (CLOSED)
 58. NOSEWHEEL DOOR/MUDGUARD (CLOSED)
 59. NOSEWHEEL FORWARD DOOR (CLOSED)

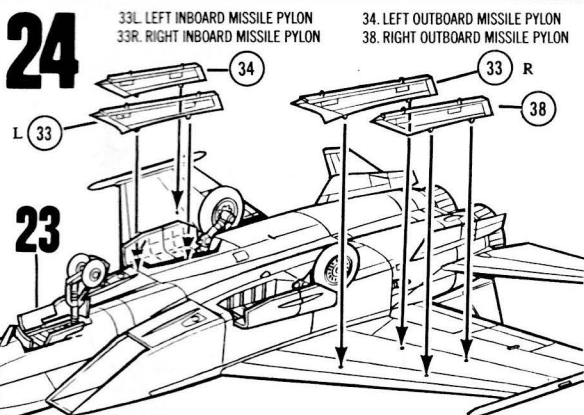

- 33L. LEFT INBOARD MISSILE PYLON
 33R. RIGHT INBOARD MISSILE PYLON
 34. LEFT OUTBOARD MISSILE PYLON
 38. RIGHT OUTBOARD MISSILE PYLON

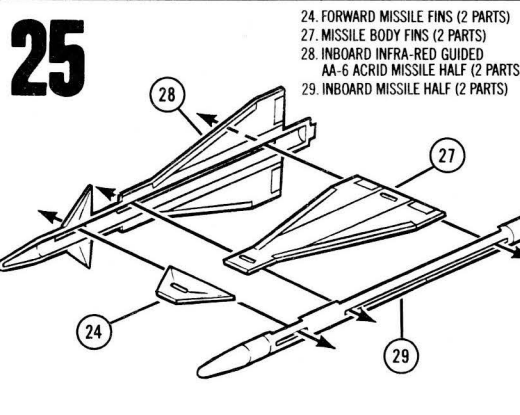

24. FORWARD MISSILE FINS (2 PARTS)
 27. MISSILE BODY FINS (2 PARTS)
 28. INBOARD INFRA-RED GUIDED AA-6 ACRID MISSILE HALF (2 PARTS)
 29. INBOARD MISSILE HALF (2 PARTS)

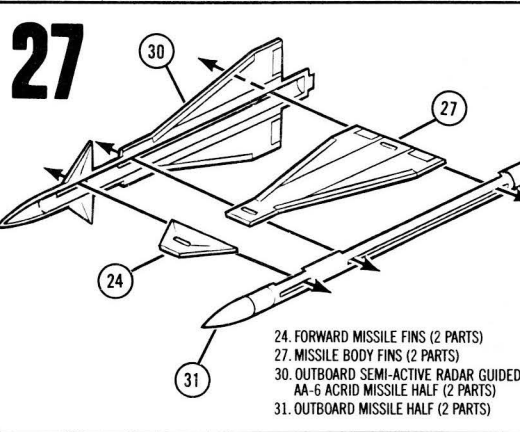
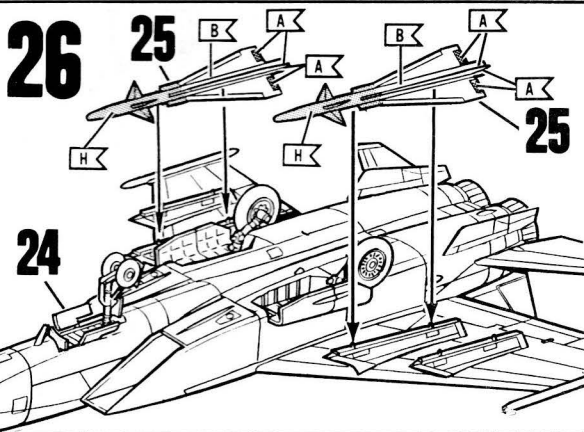

24. FORWARD MISSILE FINS (2 PARTS)
 27. MISSILE BODY FINS (2 PARTS)
 30. OUTBOARD SEMI-ACTIVE RADAR GUIDED AA-6 ACRID MISSILE HALF (2 PARTS)
 31. OUTBOARD MISSILE HALF (2 PARTS)

