

ACADEMY

HOBBY MODEL KITS

F-86F SABRE "MIG KILLER"



1/48TH SCALE

F-86F 세이버 "미그킬러"

FA187
#2183

F-86F SABRE "MIG KILLER"

Taking advantage of captured German data regarding swept-wing technology, North American designed the F-86 Sabre for the U.S. Air Force shortly after the Second World War. First flown on October 1, 1947, the F-86 was intended for use as a dive bomber or an escort fighter. A powerful thrust afterburning General Electric J47-GE-17B powerplant, capable of producing 7,500 lb of thrust, gave the Sabre the ability to fly at speeds in excess of Mach 1. The F-86 saw extensive use during the Korean War, where it was matched up against the feared Soviet-designed MiG-15. Combat experience quickly pointed out the Sabre's limited maneuverability, and the F-86F, with new redesigned and lengthened "6-3" wings, was developed. This new version, combined with the superior training and experience of American pilots, allowed the F-86 to regain control of the Korean skies and maintain an enormous advantage over the MiG-15.

Mit dem Nutzen der erfassten deutschen Daten von Schwung-Flügel-Technologie haben Nordamerikaner den F-86 Sabre für die U.S. Air Force kurz nach dem 2. Weltkrieg entworfen. Er flog zum ersten Mal am 1. Oktober 1947. Der F-86 wurde als ein Sturzkampfbomber oder ein Begleitjäger entworfen. Der eine kraftvolle Triebkraft nachbrennende General Electric J47-GE17B Motor, der 7,500 lb Triebkraft produzieren kann, gab dem Sabre die Fähigkeit, auf der Mach 1 überschreitenden Geschwindigkeit zu fliegen. Der F-86 sah umfangreiche Verwendung im koreanischen Krieg, wo er gegen den befürchteten vom Sowjetunion entworfenen MiG-15 zusammenpaßte. Die kombaterfahrung zeigte schnell auf die begrenzte Manövermöglichkeit des Sabres. Und dann wurde der F-86F mit neu entworfenen und verlängerten "6-3" Flügeln entwickelt. Diese neue version, zusammen mit der höheren Übung und Erfahrung der amerikanischen Piloten, ermöglichte den F-86, die Kontrolle im koreanischen Himmel zurückzugewinnen und einen großen Vorteil dem MiG-15 gegenüber aufrechtzuerhalten.

Tirant profit des avions allemands capturés avec leurs ailes en "V" bien spécifiques, North American dessina le F-86 Sabre peu après la 2ème G. M.

Effectuant son premier vol en octobre 1947, il fut désigné comme un chasseur d'escorte bombardier.

Sa puissante turbine de 7,500 lb, lui offrait la possibilité de voler à Mach 1.

Il fut très utilisé dans la guerre de Corée, où il descendit nombre de Mig-15, avant que les soviétiques ne reprennent la supériorité technique. Le F-86 fut remanié et de nouvelles ailes furent étudiées.

Cette version associée au talent et à l'expérience des pilotes américains, rendit au F-86 le contrôle du ciel de Corée et son avantage face aux Mig-15.

F-86 세이버는 한국전쟁기간중 공산군측의 미그15를 상대로 사상최초의 제트기 대 제트기의 대규모 공중전을 펼친 끝에, 최종적으로 10:1이라는 압도적인 격추율 스코어로 승리를 거둔 미국의 걸작 제트전투기이다. 2차대전에서 패배한 독일이 비밀리에 연구 중이던 후퇴의 항공기의 개발자료를 입수하여 기본설계에 들어간 세이버는, 1947년 10월 1일, 첫 시제기인 XP-86이 처녀비행에 성공을 거두었으며, 수차례의 시험평가를 통해 급강하 폭격 및 호위, 요격 전투기로서의 우수한 잠재성을 인정받아 본격적인 양산화의 궤도에 오르게 되었다. 특히 당시로서는 상당히 고성능이던 제너럴 일렉트릭사의 J47-GE-17B 제트엔진(추력 7,500파운드)과 후퇴익이 조합된 기체 설계는, 뛰어난 비행성능과 더불어 마하1에 육박하는 최고속도를 발휘할 수 있게 한 결정적인 성공의 열쇠가 되었다. 한국전쟁에 돌입 등 장한 미그 15를 상대하기 위해 서둘러 실전 투입된 세이버는, 공산군 측에 비해 상대적으로 우수했던 미군 조종사들의 기량에 힘입어 확실한 전과를 올려 나아갔지만, 반면 몇 가지 면에서 개선요구사항이 지적되기도 하였다. 이에 따라 새로운 개량모델로 등장한 것이 F-86F형으로서, 보다 출력이 향상된 J47-GE-27엔진을 채택한 외에, 방탄능력의 강화나 외부 무장탑재 능력의 향상 등이 중점적으로 이루어졌다. 특히 F-86F-25형 및 -30형부터는 종전까지 쓰이던 주날개를 대신하여 이른바 '6-3'형 날개로 불리는 신형 주날개를 새로이 장착하게 되는데, 이날개의 채용으로 인해 공중전에서의 비행성능이 크게 향상된 세이버는 보다 확실한 미그기에 대한 성능상의 우위를 차지할 수 있게 되어 일선 조종사들로부터 큰 호평을 받았다. 또한 신규 생산기체 이외에도 이미 생산되어 사용 중이던 많은 기체가 현지개수를 통해 '6-3'형 날개로 전환함에 따라 이 형식은 세이버 시리즈의 가장 대표적인 모델로 자리잡게 되었다.

 Component Parts Liste des pièces Haben Haben Haben Haben Haben	 Component Parts Liste des pièces Haben Haben Haben Haben Haben	 3 수단용 도형 Reiser operation Reiser operation Vorlag wandelzeichen Reiser operation Reiser operation Reiser operation	 Decals Decalcomanias Abziehbild 전사지를 붙인다. Decals Decalcomanias Abziehbild	 9 Add-weight Laster Gewicht 무중량을 넣는다. Add-weight Laster Gewicht	 Use file Metallfeile Schleifen 구멍이나 홈을 채워준다. Use file Metallfeile Schleifen
 Cap Cap Cap Cap Cap	 ? Direction Direction Direction Direction Direction	 ? Repeat for opposite side Wiederholung für gegenüberliegende Seite 반대쪽도 도형한다. Repeat for opposite side Wiederholung für gegenüberliegende Seite	 Holes Holes Holes Holes Holes	 ! Holes Holes Holes Holes Holes	 ! Holes Holes Holes Holes Holes

<READ THIS BEFORE YOU BEGIN>

- Study the instructions before assembling.
- Check the fit of each piece before cementing into place.
- Do not use too much cement to join parts.
- Never use cement or paint near open flame.
- Open a window or make area well ventilated when cement or paint is in use.
- Tear up and throw away the empty plastic bags to avoid danger of suffocation for little children.

<LISEZ CE QUI SUIT AVANT DE COMMENCER LE MONTAGE>

- Étudier les schémas d'assemblage.
- Contrôler que chaque pièce soit bien conforme avant de la coller à sa place.
- N'utilisez pas trop de colle pour réunir les pièces.
- Ne faites manipuler la colle ou peinture à proximité d'une flamme.
- Aérer soigneusement la pièce où vous peignez (ouvrez la fenêtre).
- Après avoir sorti les pièces du sac en plastique, déchirer le sac afin d'éviter que les enfants ne le mettent sur la tête et ne s'étouffent.

<ALLGEMEINE HINWEISE>

- Die Anordnung der Bauteile ist aus den Zeichnungen der Anleitung ersichtlich.
- Die Teile vor dem Verleimen ungeleimt zusammenhalten, um ihren paßbüß zu prüfen.
- Klebstoff nicht zu dick auftragen.
- Klebstoff und Farben niemals in der Nähe einer Flamme verwenden.
- Während der Bemalung mit Spritzpistole oder Pinsel für frische Luftzufuhr, z.B. öffnen des Fensters, sorgen.
- Bausatz von Kleinen Kindern fernhalten. Verhüten Sie, daß Kinder irgendwelche Bauteile in den Mund nehmen oder Plastiktüten über den Kopf ziehen.

■ 조립하기 전에

- 부품을 조립하기 전에 설명서를 잘 읽어본 후 조립한다.
- 부품을 자를 때에는 칼이나 나뭇로 깨끗이 잘라준다.
- 접착제를 사용할 곳과 사용하지 않는 곳에 주의하고 너무 많이 바르지 않도록 한다.
- 접착하기 전에 부품을 맞추어 확인한 후 조립한다.
- 에나멜 페인트나 접착제를 사용할 때는 창문을 열어 환기를 시키고 화기를 멀리한다.
- 사용 후 남은 부품은 어린이들의 손에 닿지 않도록 잘 처리한다.

pit : interior green puis interior gray (FS 26231)
 en mi ou fin 1953
 bases de train et intérieur AF : interior green
 intérieur portes bagages train : métal nu/silver
 ou pit tout noir appaître rouge

1

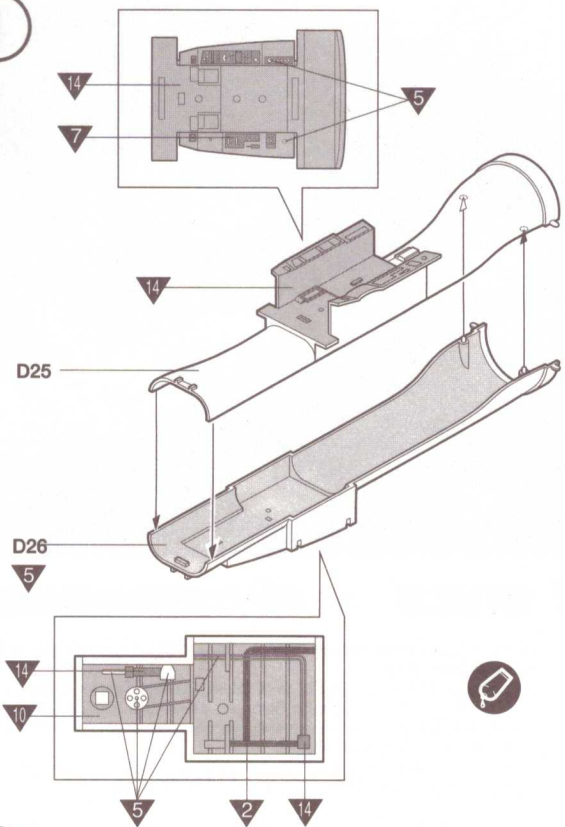

2

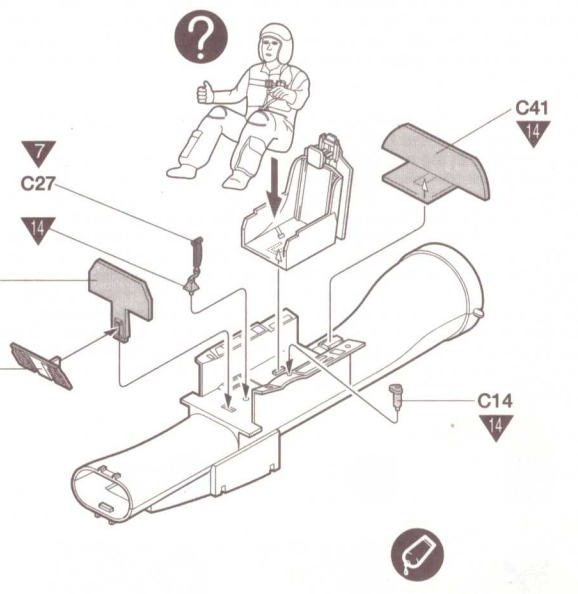
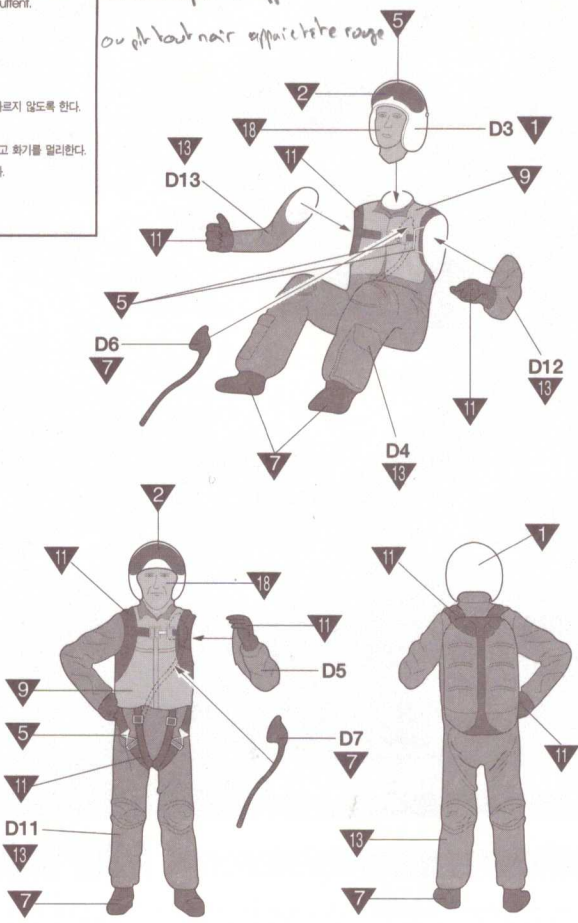
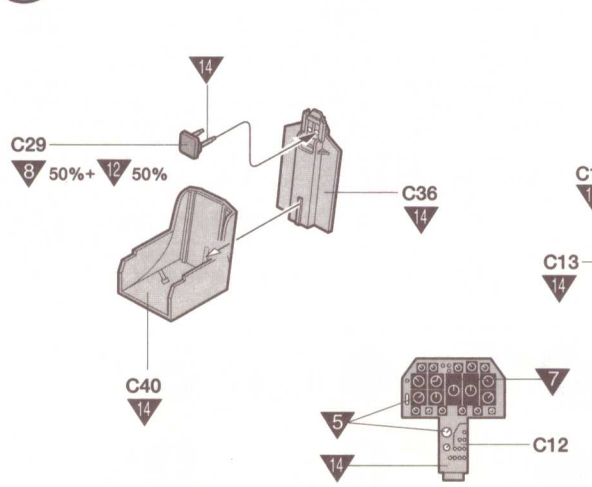

3

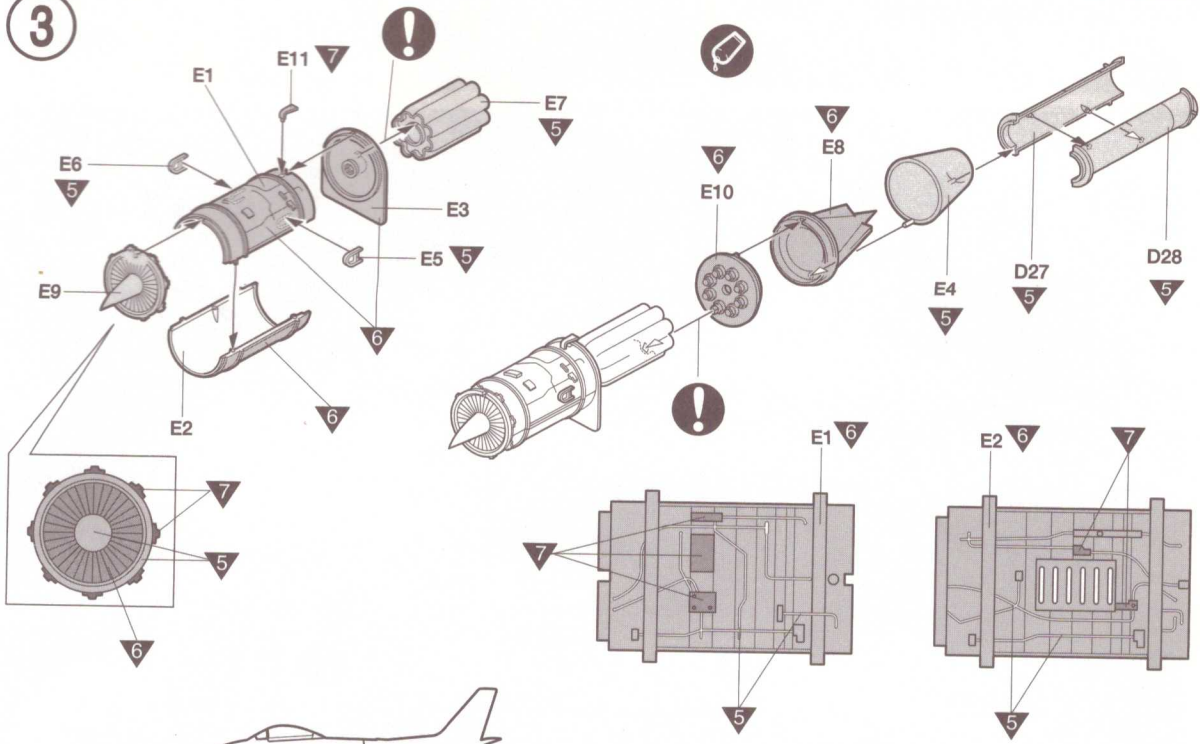

4

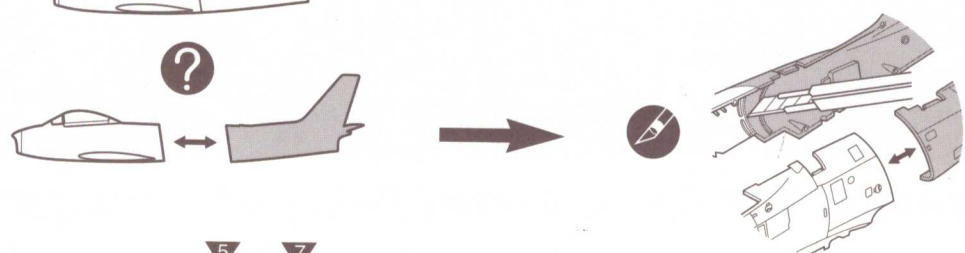

* See step 15.
 정비상태로 조립할 경우에는 동체를
 절단해 준다. (참조 15)

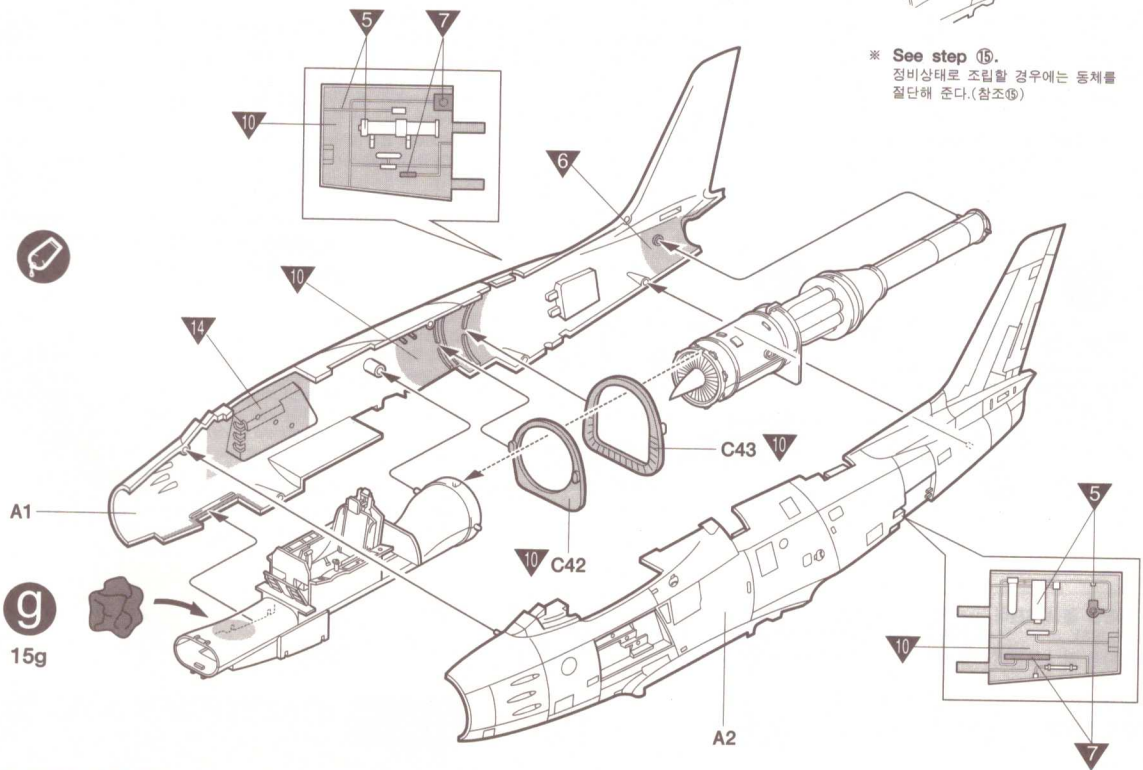

5

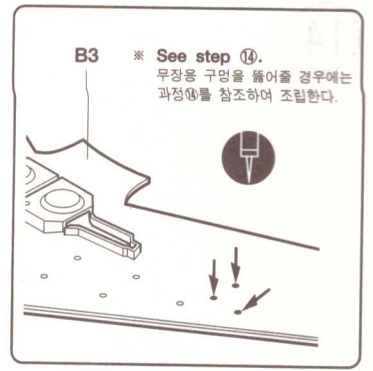
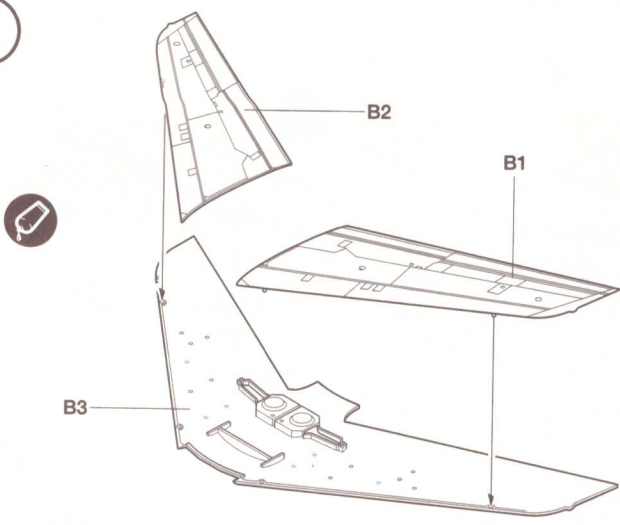

B3 * See step ④.
무장용 구멍을 뚫어줄 경우에는
과정④를 참조하여 조립한다.

6

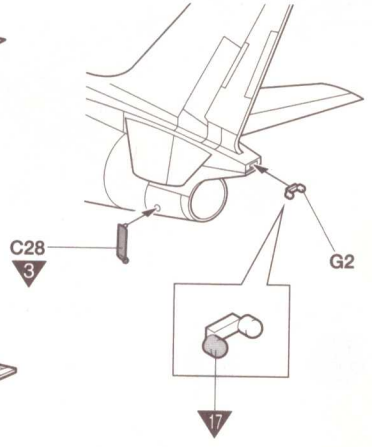
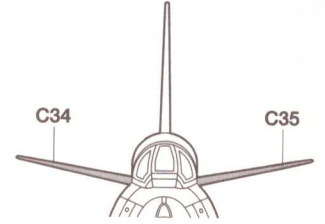
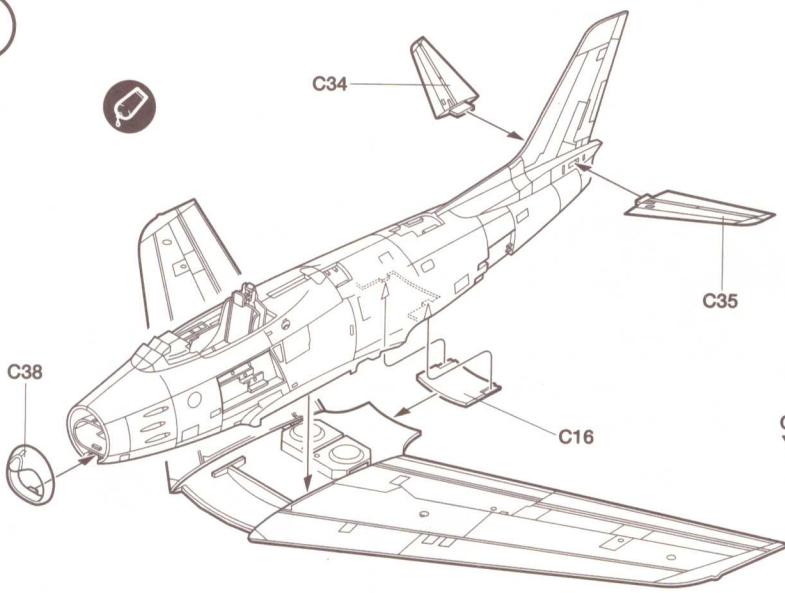

7

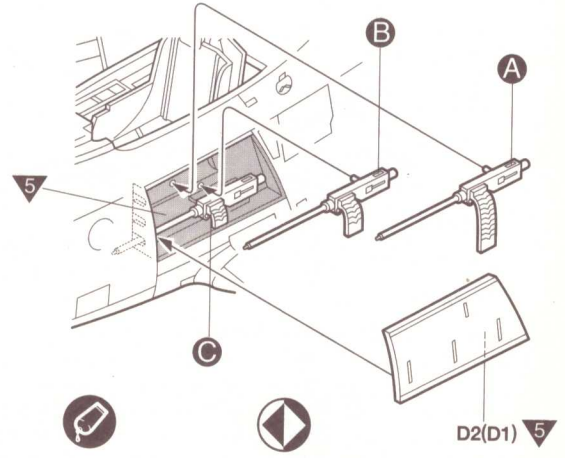
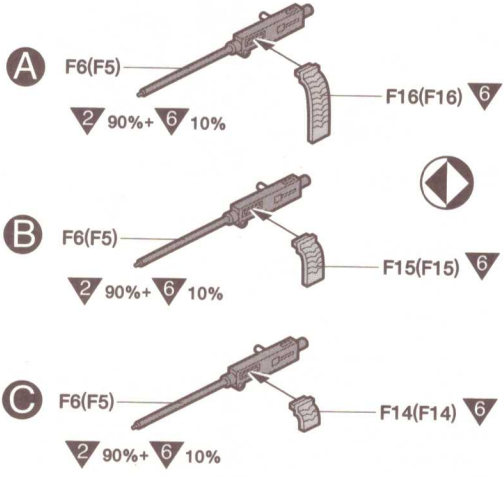

8

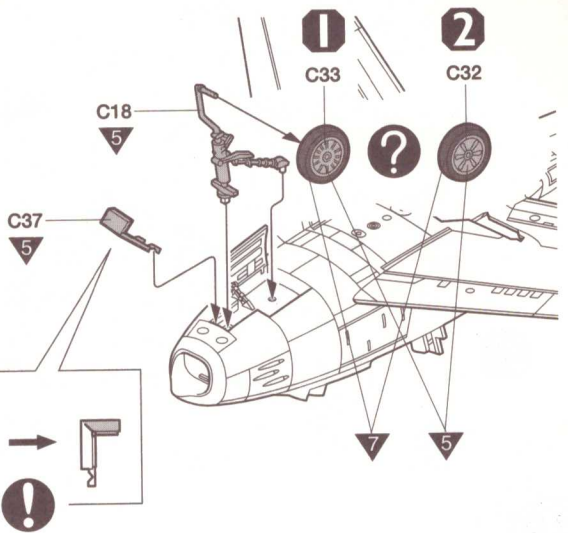
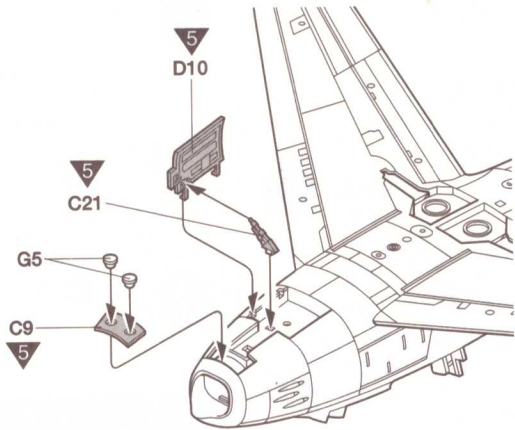

9

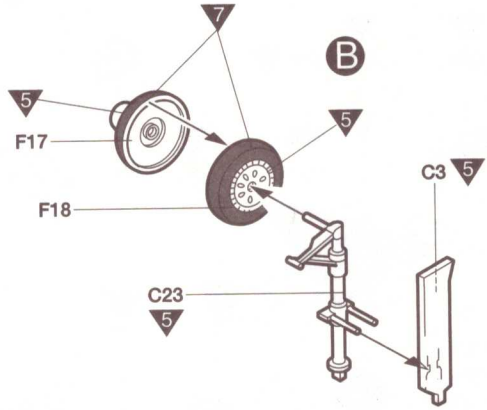
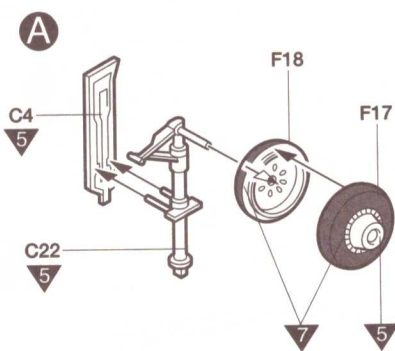

10

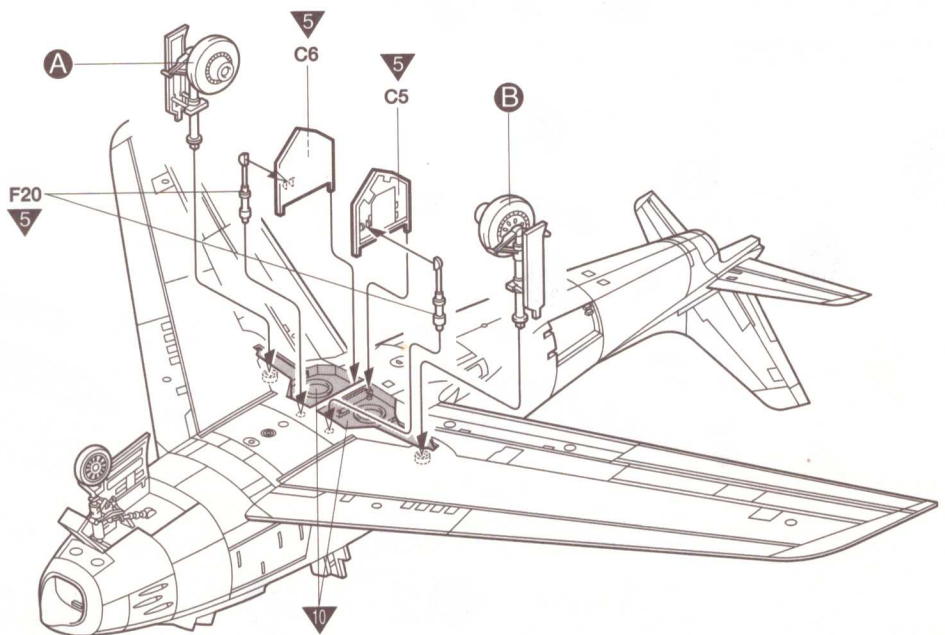

11

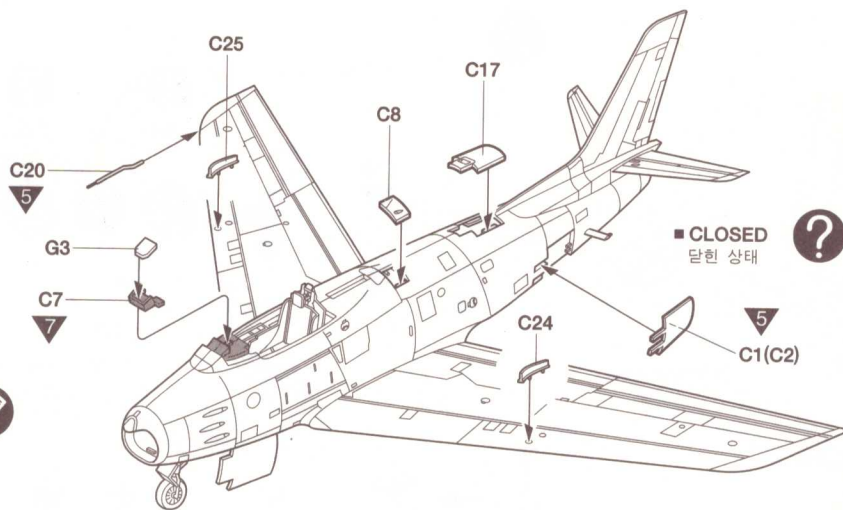

■ OPEN 열린 상태

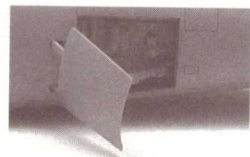
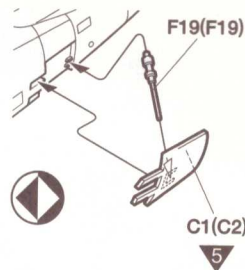
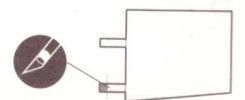

■ CLOSED 닫힌 상태



12

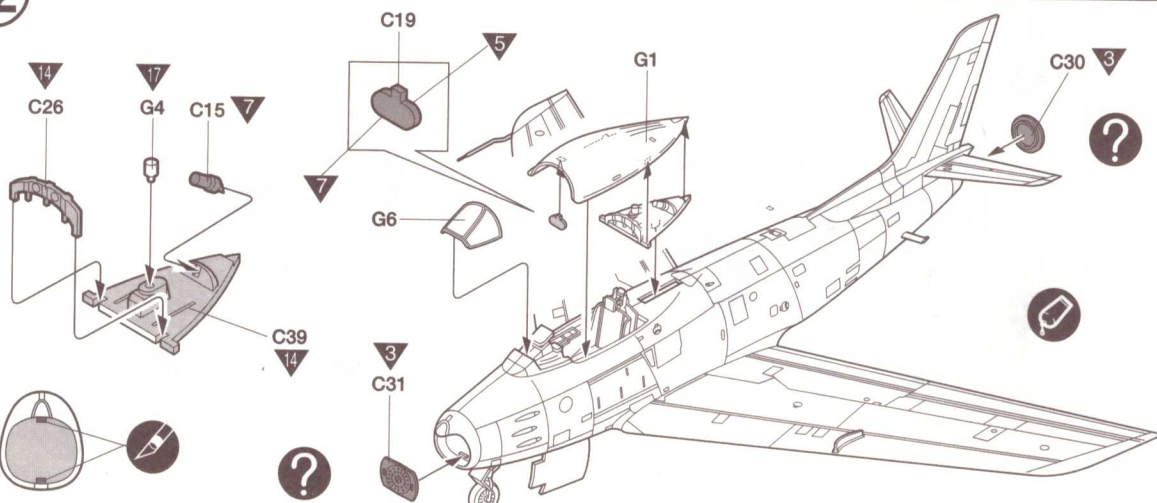

※ Remove for open intake.
 먼지덮개(C31)를 조립하지않을때는
 잘라준다.

13

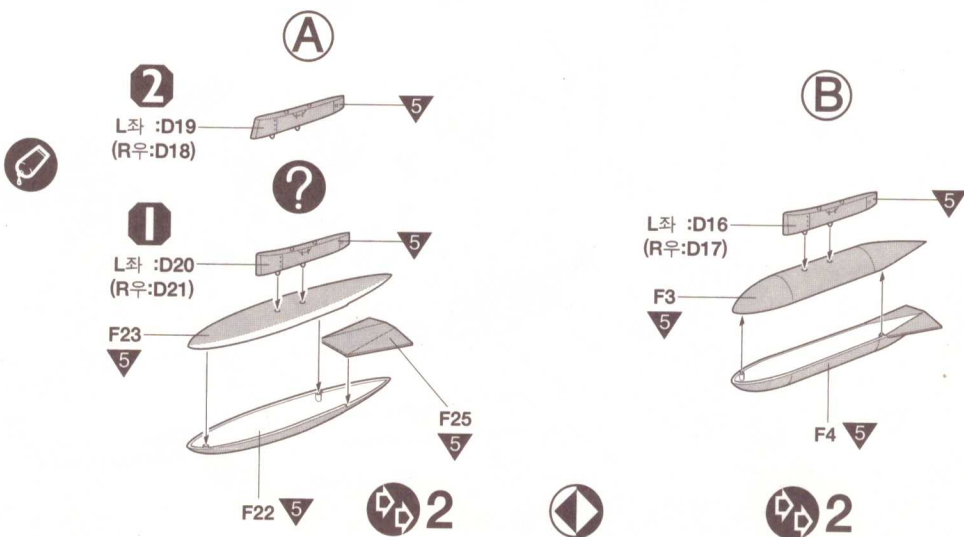

14

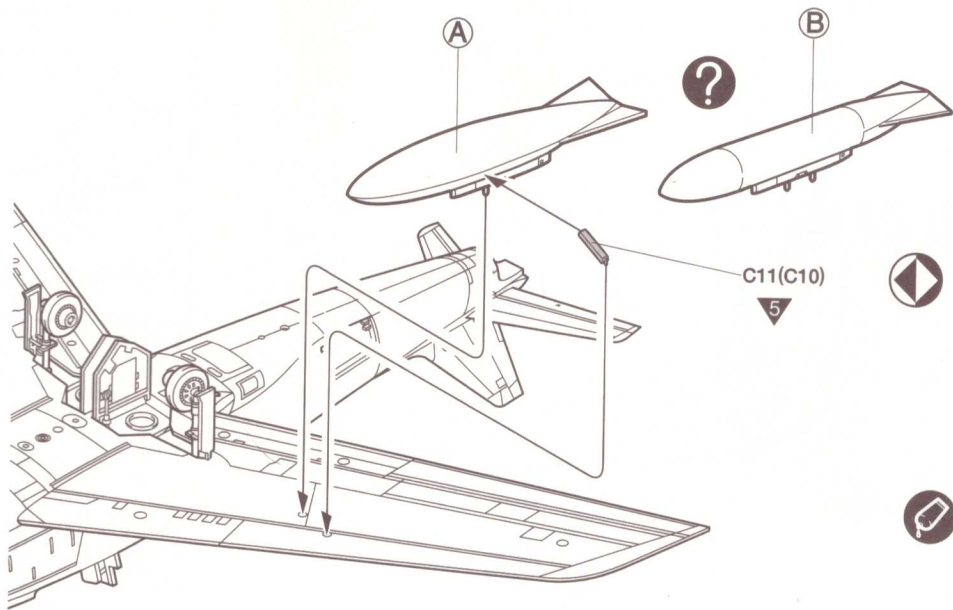

15

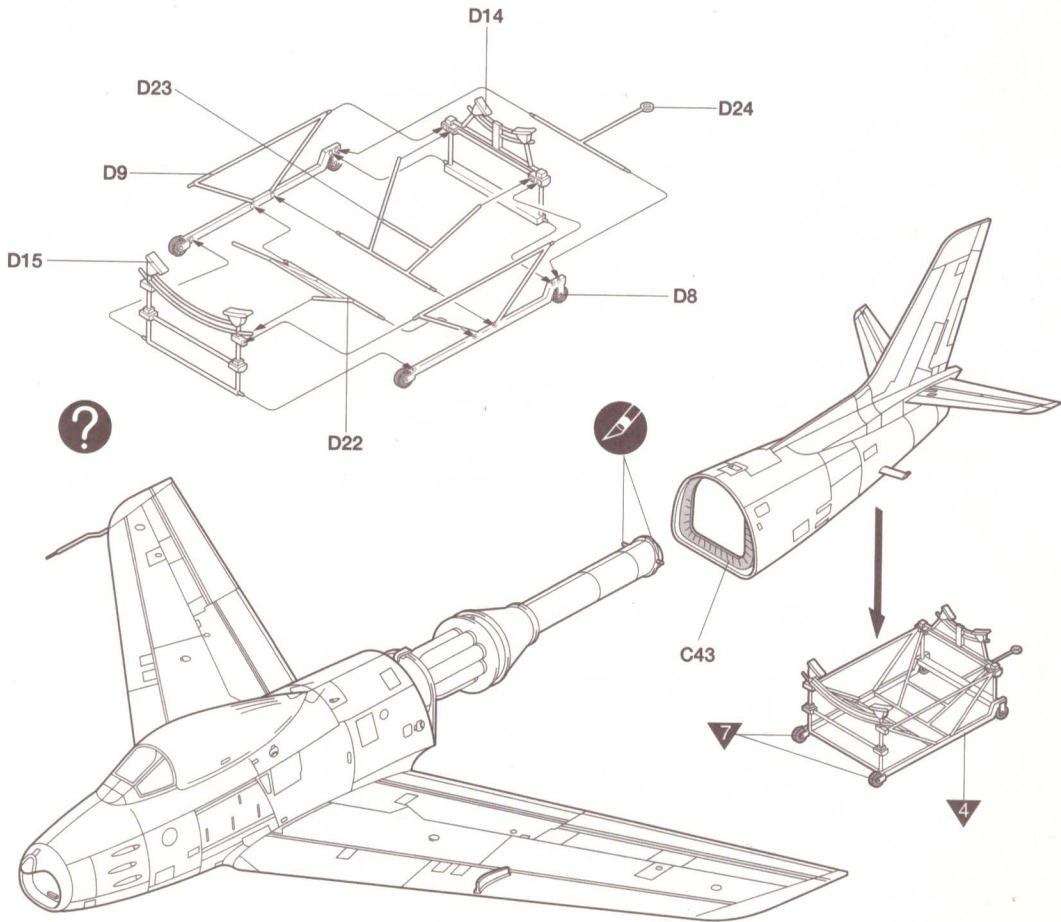

1	WHITE	WEISS	BLANC	ホワイト	유광 흰색	6	GUN METAL	METALL-GRAU	GRIS ACIER	ガンメタル	건재탈	11	KHAKI	KHAKI	KHAKI	카키	카키색	12	CLEAR BLUE	BLAU REIN	BLEU CLAIR	クリア블루	클리어 블루
2	BLACK	SCHWARZ	NOIR	블랙	유광 검정색	7	FLAT BLACK	MATT SCHWARZ	NOIR MAT	つや無しブラック	무광 검정색	13	RED BROWN	ROT BRAUN	ROUGE BRUN	레드브라운	레드 브라운	13	CLEAR ORANGE	ORANGE REIN	ORANGE CLAIR	クリア오렌지	클리어 오렌지
3	RED	ROT	ROUGE	레드	유광 빨강색	8	FLAT RED	MATT ROT	ROUGE MAT	つや無し레드	무광 빨강색	14	KHAKI GREEN	KHAKI GRÜN	VERT KHAKI	카키그린	카키 그린	14	FLAT FLESH	HAUTFARBE	CHAIR	민색(フラッシュ)	살색
4	YELLOW	GELB	JAUNE	イエロー	유광 노랑색	9	FLAT YELLOW	MATT GELB	JAUNE MAT	つや無しイエロー	무광 노랑색	15	DARK GRAY	DUNKEL GRAU	GRIS FONCE	다크그레이	다크 그레이	15	OLIVE GRAB	OLIV GRÜN	VERT OLIVE	올리브드랍	국방색
5	SILVER	SILBER	ARGENT	실버	은색	10	INTERIOR GREEN	INNEN GRÜN	VERT INTERIEUR	인테리어그린	인테리어 그린	16	CLEAR RED	ROT REIN	ROUGE CLAIR	클리어 레드	클리어 레드	16	ARCAMT GRAY	FLUGZEUGGRAU	GRIS AVION	에어크래프트그레이	에어크래프트 그레이

Parts Locating Diagram 부품도

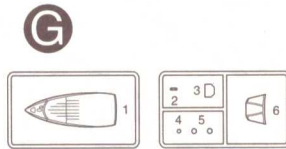
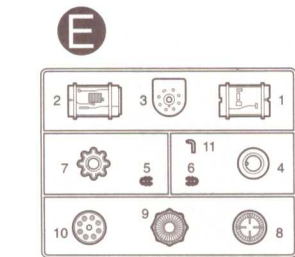
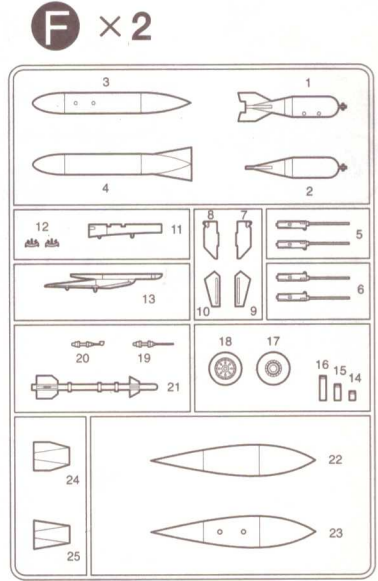
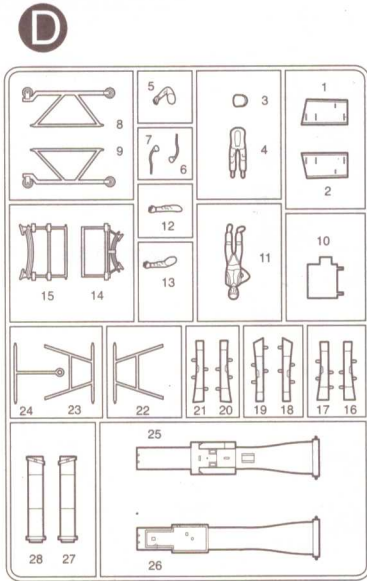
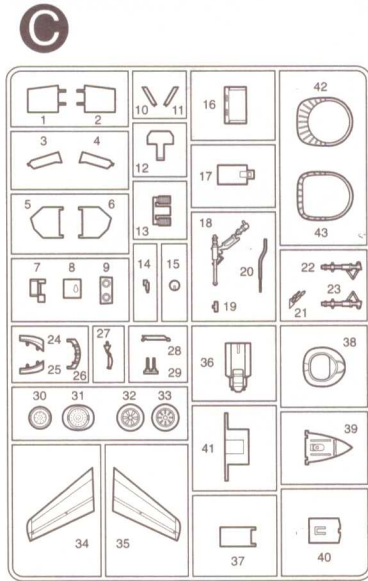
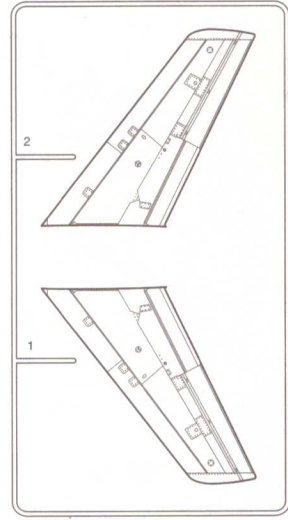
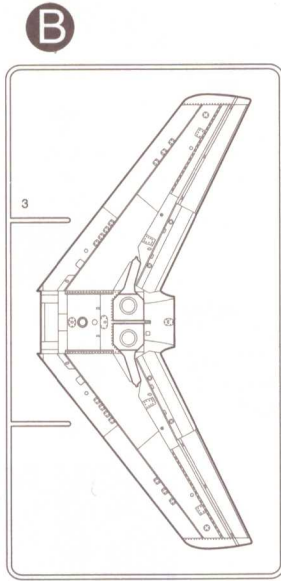
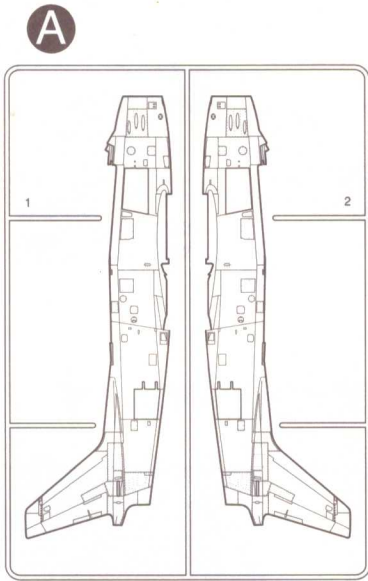

- DECAL 전사지 × 1
- CEMENT 접착제 × 1

■ Unused parts
 Nicht verwenden
 Pièces non utilisées
 不要部品
 불필요 부품

F1, F2, F5×1, F6×1,
 F9, F10, F11, F12,
 F13, F21, F24

- 직매점 겸 A/S센터
- A/S센터
- 총판점 겸 A/S센터
- 홈페이지
- ♣고객상담문의

삼선교: 742-9293, 대치동: 552-9293, 양재동: 575-9997, 용산: 796-1214, 아셈하비센터: 6002-6293
 본사: 908-7000(교환147), 동대문: 745-9293, 천호동: 473-9293
 노원아카데미: 907-0940, 양천아카데미: 691-7108, 강남아카데미: 485-6884, 강북아카데미: 762-0980,
 경기아카데미: (0343)458-5591, 부산아카데미: (051)293-7449, 대구아카데미: (053)744-9293
<http://www.academyhobby.com> <http://www.academy.co.kr>
 080-969-7000

ACADEMY HOBBY MODEL KITS
ACADEMY PLASTIC MODEL CO., LTD.
 273-64, Suyu-dong, Kangbuk-gu, Seoul, Korea
 TEL:82-2-908-7000 FAX:82-2-997-3003

1 F-86F(#51-2910), Capt. Joseph McConnell, 39th FIS/51st FIW, Korea, 1953
 F-86F(#51-2910), 제 51 전투요격비행대 제 39 전투요격비행대 소속 조셉 맥코넬 대위 탑승기, 1953년 한국

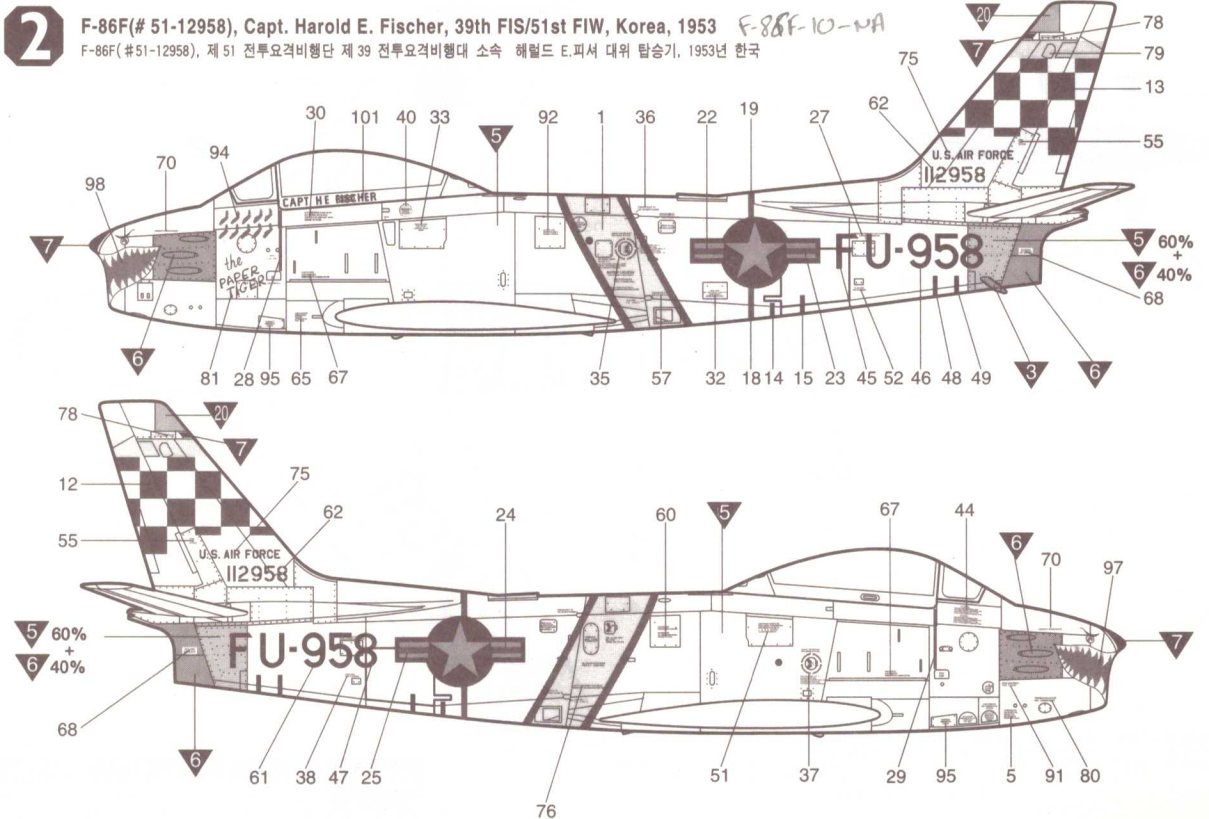
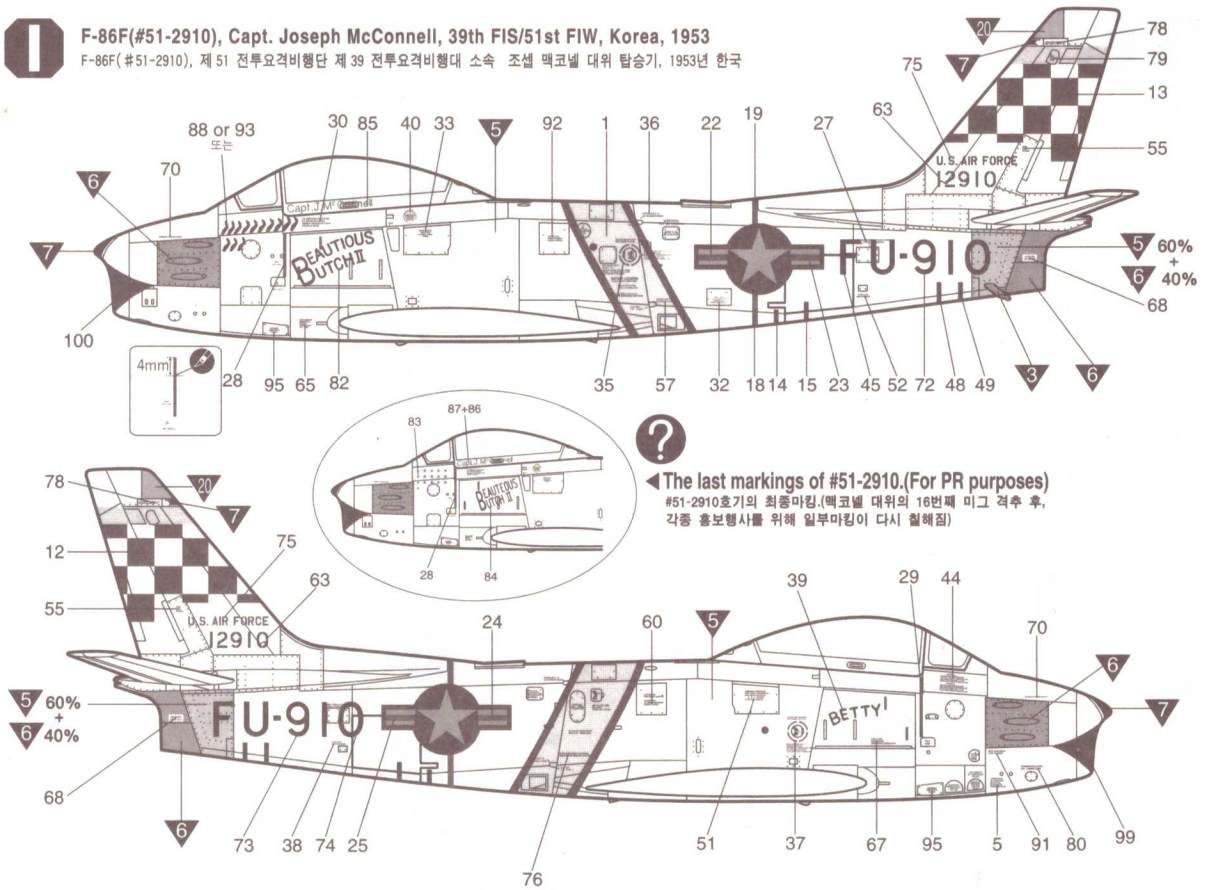

1 2

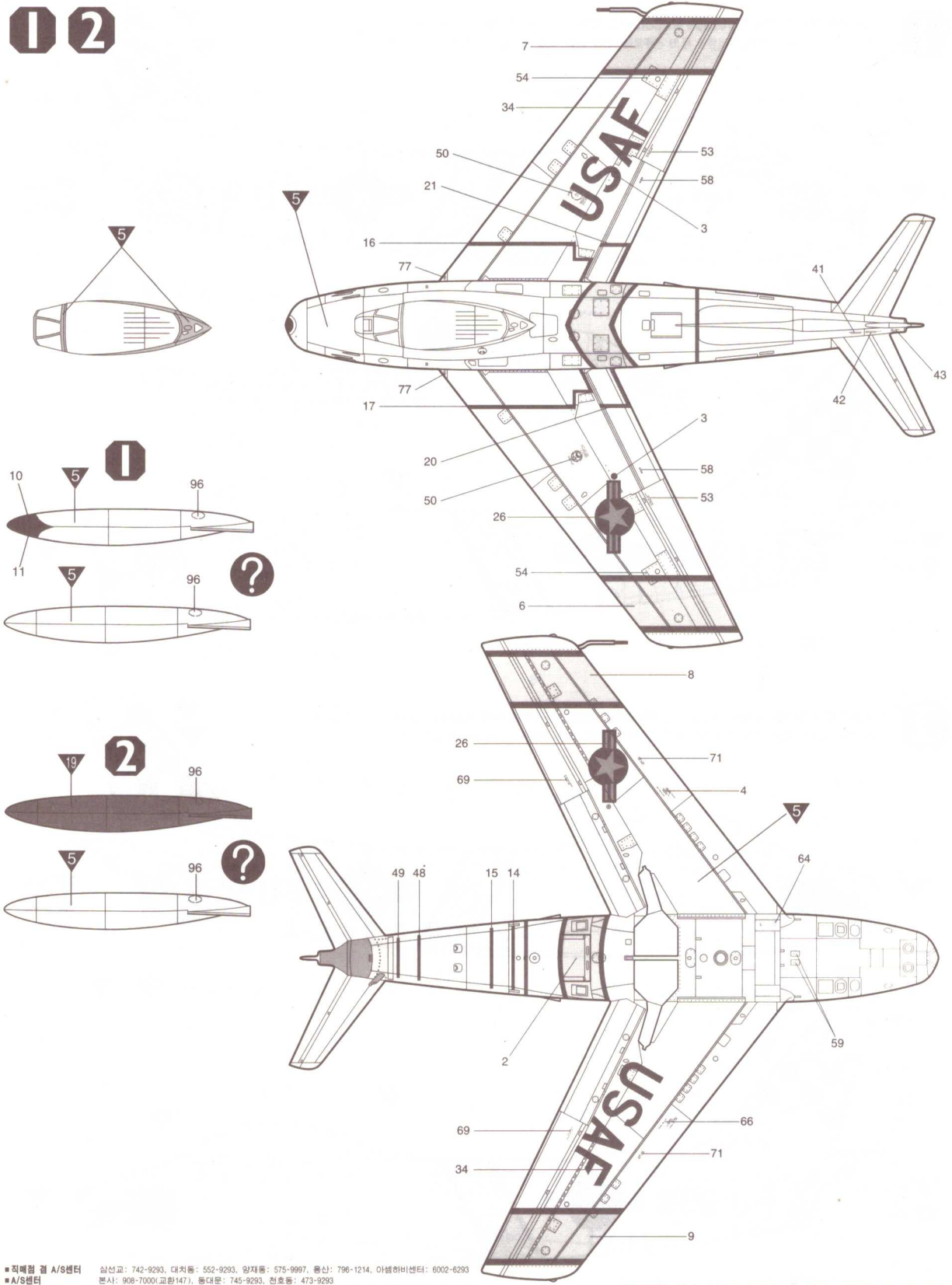

■ 직매점 겸 A/S센터 심선교: 742-9293, 대치동: 552-9293, 양재동: 575-9997, 홍산: 796-1214, 아셈허비센터: 6002-6293
 ■ A/S센터 본사: 908-7000(교황147), 동대문: 745-9293, 천호동: 473-9293
 ■ 출판점 겸 A/S센터 노원아카데미: 907-0940, 양천아카데미: 691-7108, 강남아카데미: 485-8884, 관북아카데미: 762-0880,
 경기아카데미: (0343)458-5591, 부산아카데미: (051)293-7449, 대구아카데미: (053)744-9293
 ■ 홈페이지 http://www.academyhobby.com http://www.academy.co.kr
 ■ 고객센터 080-969-7000

ACADEMY HOBBY MODEL KITS **ACADEMY PLASTIC MODEL CO., LTD.**
 273-64, Suyu-dong, Kangbuk-gu, Seoul, Korea
 TEL: 82-2-908-7000 FAX: 82-2-997-3003