

VOUGHT F4U-7 CORSAIR

Art No72/024

**F4U-7 - Flottille 12F
KAROUBA & INDOCHINE (PA La Fayette) - 1955**

Bleu Nuit
Sea Blue Gloss

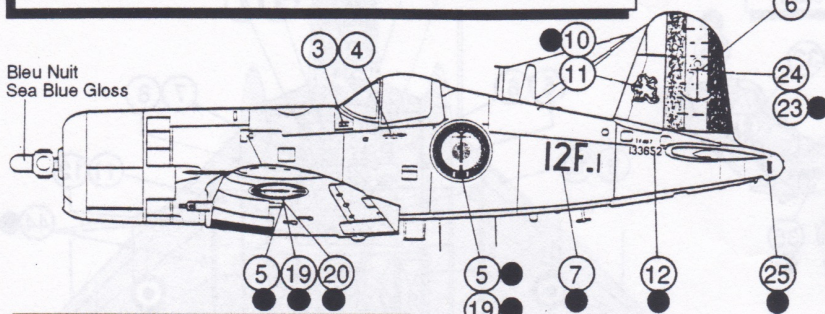

**F4U-7 - Flottille 14F
SUEZ (PA Arromanchs) - 1956**

Blanc
White

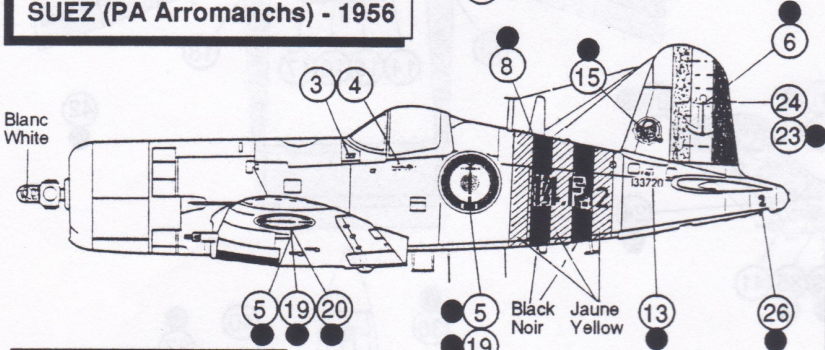

**F4U-7 - Flottille 17F
BIZERTE - 1959**

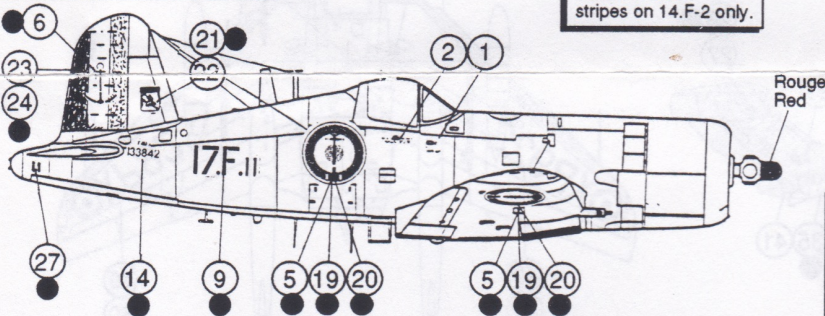

● indique marquage des deux côtés.
indicates marking on both sides.

Tous les appareils sont entièrement Bleu Nuit Brillant.
All machines overall Sea Blue Gloss.

Décal 1 2 3 4 sur tous les appareils.
Transfers 1 2 3 4 on all aircraft.

Flottille 14F

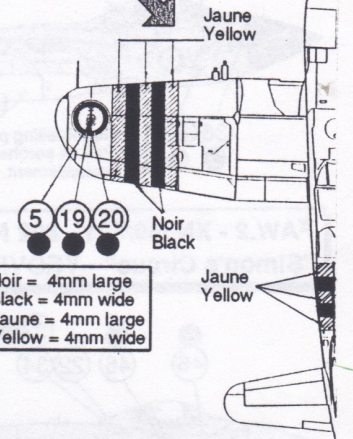

Noir = 4mm large
Black = 4mm wide
Jaune = 4mm large
Yellow = 4mm wide

Noter que les appareils avaient souvent un aspect délavé dû aux effets de l'environnement marin dans lequel ils opéraient.
Note that aircraft had worn out finish and numerous scuff marks on wings & access panels.

Flottilles 12F & 17F

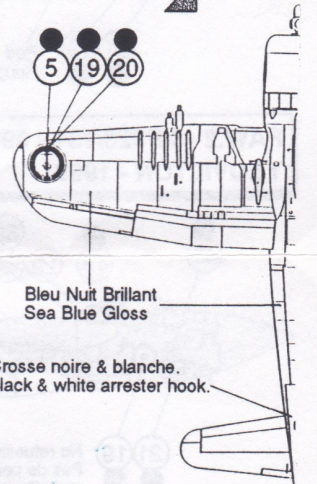

Bleu Nuit Brillant
Sea Blue Gloss

Crosse noire & blanche.
Black & white arrester hook.

Hélices: noir mat, bouts de pales jaunes, casserole Bleu Nuit sur tous les appareils.
Matt black propellers, yellow tips & Sea Blue Gloss boss on all machines.

EMBRAER EMB-312F TUCANO

Art No72/024

**D.V.05/312 - École de l'Air
SALON DE PROVENCE - 1995**

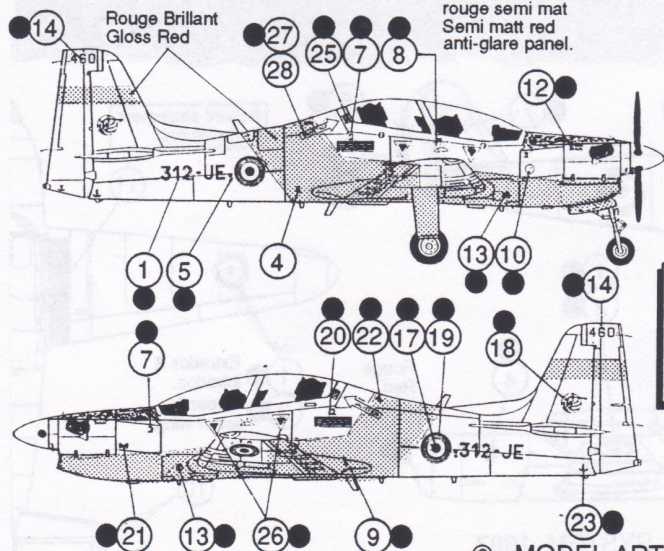

Panneau anti-reflets rouge semi mat
Semi matt red anti-glare panel.

Hélice: face avant gris métallisé, face arrière noir mat. Bouts de pales et bande orange.
Propeller: metallic grey front, matt black rear, orange tip & stripe.

Métal poli.
Polished metal.
Métal brûlé
Burnt metal

Blanc Brillant
Gloss White

La position des marquages est identique sur tous les appareils.
Pour "312-JJ/465" et "312-JL/467" utiliser les décalques 2, 3, 15 & 16.
Markings in identical position on all aircraft. Use decals 2, 3, 15 & 16 for "312-JK/465" "312-JL/467".

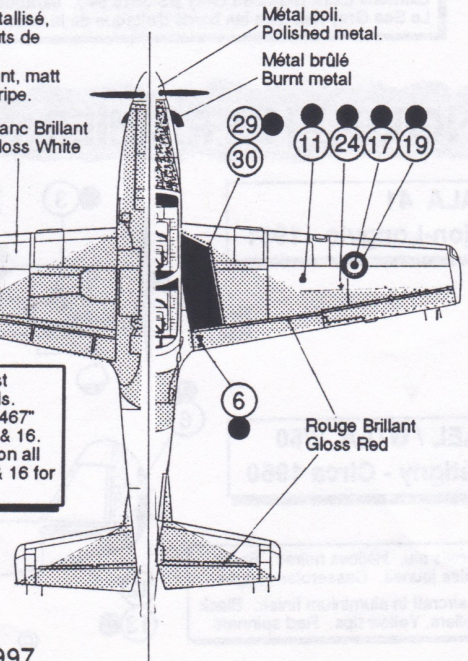

Rouge Brillant
Gloss Red

DE HAVILLAND SEA VIXEN

Art No72/024

**FAW.1 - XN647/490/VL - 899 NAS
YEOVILTON - 1962**

Semi-gloss
Black
Noir semi-brillant

Gloss White
canopy frame.
Montants de verrière
Blanc Brillant.

● indicates marking
on both sides.
indique marquage
des deux côtés.

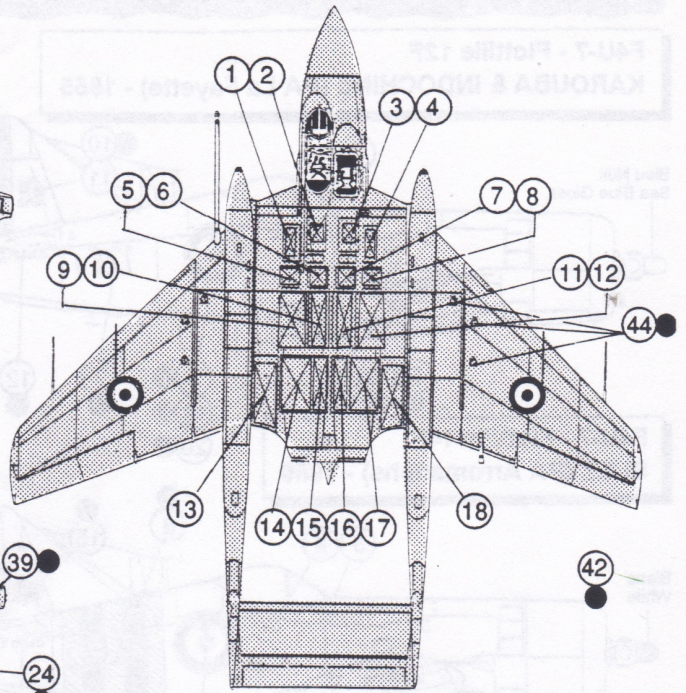
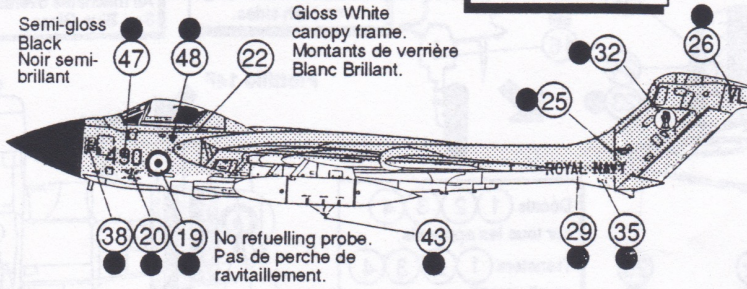

**FAW.2 - XN650/301 - 892 NAS
"Simon's Circus" - YEOVILTON - 1968**

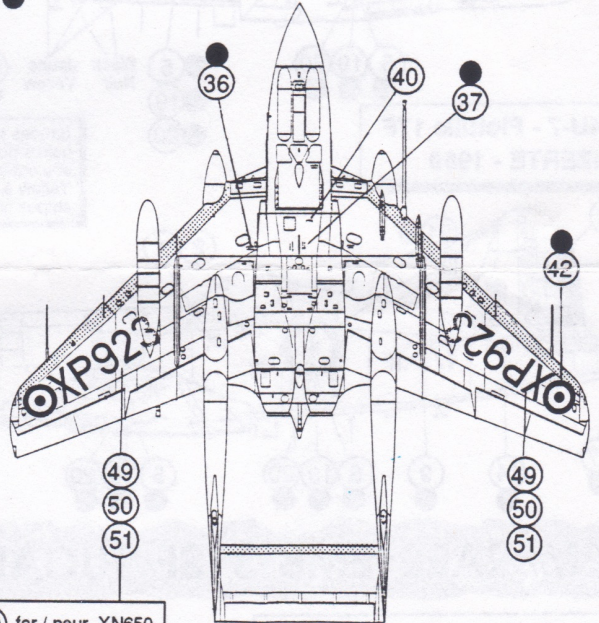
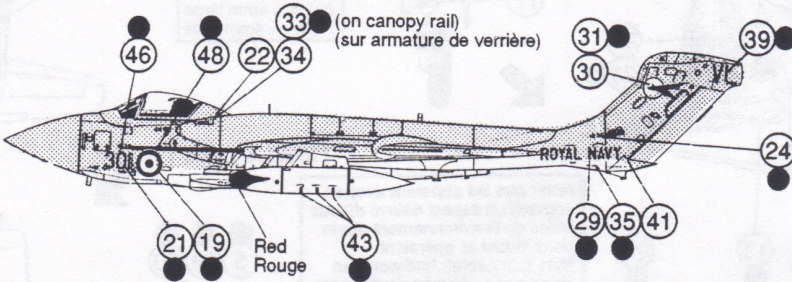

**FAW.2 - XP923/751 - 890NAS
YEOVILTON - 1968**

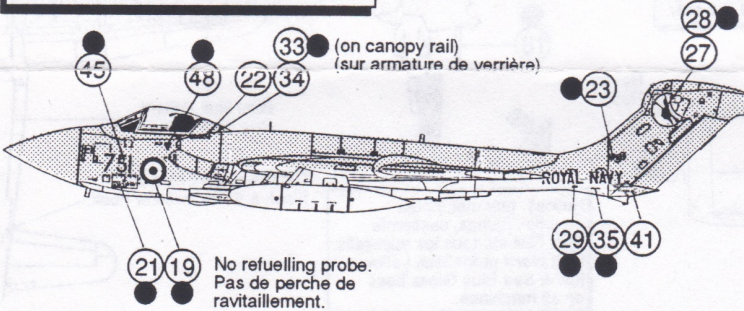

Upper surfaces Extra Dark Sea Grey BS.381c/640. Gloss White lower surfaces. Sea Grey overlaps wing & tail surfaces leading edges.
Extrados Extra Dark Sea Grey BS.381c/640. Intrados Blanc Brillant.
Le Sea Grey recouvre les bords d'attaque de la voilure et du stabilo.

50 for / pour XN650
51 for / pour XN647

NORD 1101 RAMIER

Art No72/024

**EALA 41
Dijon-Longvic - 1961**

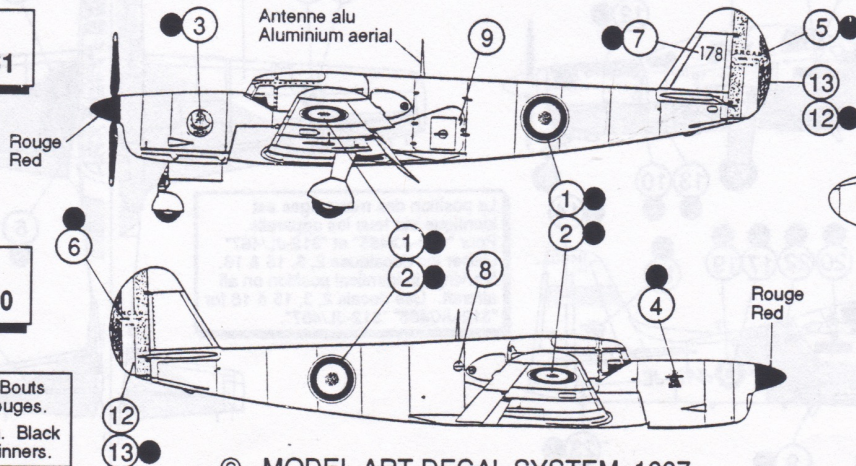

Bâbord seulement
Port side only

**GAEL / GTLA 2/60
Brétigny - Circa 1960**

Appareils alu. Hélices noires. Bouts de pales jaunes. Casseroles rouges.
Both aircraft in aluminium finish. Black propellers. Yellow tips. Red spinners.

1 Extrados & intrados.
2 Upper & lower wing.