

ACADEMY

HOBBY MODEL KITS

P-40C TOMAHAWK



P-40C 토마호크

1/48th Scale

P-40C Hawk series fighters of Curtiss Wright had been supplied to Great Britain, France, China, Australia, South Africa, New Zealand and Russia and they served as a workhorse during WW II over whole battle field. Due to the lack of output of the Allison engine, it was considered as a 2nd class fighter in the climbing power, turning performance and the speed. However, many ace pilots could have been born thanks to its solid fuselage structure, reliable equipment and pilots' excellent strategic technique.

P-40C Tomahawk (as the company called No. Hawk 81A-2/3) is an early model of P-40 series and the when it was exported, it was called as Mk. II B. Its first flight was done on April 10, 1941. It was equipped with a new fuel supplying system and the radio equipment so it could bring much more fuels by 134 gallons, which finally enlarged the fighting range. All 16,802 P-40s of 12 kinds were produced and the C-type among these were 1705. Currently only one of these were restored to be able to fly again and this had its flying test on September 1, 1998.

<SPECIFICATION>

| | | |
|--|--|--|
| Wingspan : 11.37m | Powerplant : Allison V-1710-33(Watercooled) | Armament : Nose guns 12.7mm × 2(each 380 rounds), |
| Length : 9.68m | Max. output : 1,040hp | main wing 7.7mm × 4(outer guns 480 rounds, |
| Height : 3.77m | Max. speed : 555km/h | internal guns each 500 rounds), |
| Wing area : 21.92m ² | Rising time : 808m/min | Bombs |
| Empty weight : 2,636kg | Absolute ceiling : 8,990m | |
| Max. take-off weight : 3,424kg | Cruising range : 1,287km | |

커티스 라이트사의 P-40호크계열 전투기는 미국군 항공대 및 영국·프랑스·중국·호주·남아공·뉴질랜드·소련 등에 대량으로 공여되어 제 2차 세계대전 중 전 기간 전 지역에 걸쳐 사용된 연합군의 주력 전투기이다. 탑재된 엘리스 엔진의 고질적인 출력부족으로 인해 상승력, 선회성능, 속도 등에서 2류급 전투기로 취급되었으나 튼튼한 기체구조와 정비의 신뢰성, 우수한 조종사의 전술 기량 등을 바탕으로 각 전선에서 추축국의 항공기들과 대결하여 다수의 에이스 파일럿을 배출했다.

P-40C 토마호크(커티스사 사내명 Hawk 81A-2/3)는 P-40 시리즈의 초기형으로 수출모델은 토마호크 Mk.II로 불리며 1941년 4월 10일에 첫 비행을 실시했다. 이전의 B형에 비해 새로운 연료공급 시스템과 무전장비가 탑재되었고 134갤런의 연료를 더 실을 수 있어 전투행동반경이 증대되었다.

P-40 시리즈는 실험기를 포함하여 총 12종 16,802대가 생산되었으며 이중 C형은 1,705대를 차지한다. 현재 비행 가능한 기체로는 최근 복원이 완료되어 1998년 9월 1일에 첫 비행을 실시한 단대의 기체가 존재하고 있다.

<재원>

| | |
|-----------------------------------|--------------------------------|
| 폭 : 11.37m | 엔진 : 엘리스 V-1710-33(수냉식) |
| 길이 : 9.68m | 최대출력 : 1,040hp |
| 높이 : 3.77m | 최대속도 : 555km/h(4,570m) |
| 날개면적 : 21.92m ² | 상승시간 : 808m/min |
| 자중 : 2,636kg | 실용상승한도 : 8,990m |
| 전비중량 : 3,424kg | 항속거리 : 1,287km |

무장 : 기수 12.7mm × 2(각 380발),
주날개 7.7mm × 4(바깥쪽 각 480발,
안쪽 각 500발),
폭탄류

<READ THIS BEFORE YOU BEGIN>

- Study the instructions before assembling.
- Do not use too much cement to join parts.
- Open a window or make area well ventilated when cement or paint is in use.
- Check the fit of each piece before cementing into place.
- Never use cement or paint near open flame.
- Tear up and throw away the empty plastic bags to avoid danger of suffocation for little children.

<ALL GEMEINE HINWEISE>

- Die Anordnung der Bauteile ist aus den Zeichnungen der Anleitung ersichtlich.
- Die Teile vor dem Verkleben ungleichzeitig zusammenhalten, um ihren paß zu prüfen.
- Klebstoff nicht zu dick auftragen.
- Klebstoff und Farben niemals in der Nähe einer Flamme verwenden.
- Während der Bemalung mit Spritzstoke oder Pinsel für frische Luftzufuhr, z.B. öffnen des Fensters, sorgen.
- Bausatz von kleinen Kindern fernhalten. Verhüten Sie, daß Kinder irgendwelche Bauteile in den Mund nehmen oder Plastiküten über den Kopf ziehen.

<LISEZ CE QUI SUIT AVANT DE COMMENCER LE MONTAGE>

- Etudier les schémas d'assemblage. - Contrôler que chaque pièce soit bien conforme avant de la coller à sa place.
- N'utilisez pas trop de colle pour réunir les pièces. - Ne laissez pas la colle ou peinture à proximité d'une flamme.
- Aérer soigneusement la pièce où vous peignez(ouvrir la fenêtre). - Après avoir sorti les pièces du sac en plastique, déchirer le sac afin d'éviter que les enfants ne le mettent sur la tête et ne s'étouffent.

<組み立てる前に>

- 組み立てる前に説明書をお読み下さい。 - 部品をランナーから切りはなす時は模型用ニッパーとカッターを使用します。
- 接着剤を少なめに使うことがきれいに仕上げるコツです。 - 接着する前に部品を合わせて確かめます。
- 接着剤や塗料を使用する時はときどき窓を開けて換気に気を付けましょう。
- 組み立て後の部品やビニール袋は小さな子供の届かない安全所に保管して下さい。

■조립하기 전에

- 부품을 조립하기 전에 설명서를 잘 읽어본 후 조립한다. - 정착하기 전에 부품을 맞추어 확인한 후 조립한다.
- 부품을 자를 때에는 칼이나 나이프로 깨끗이 잘라낸다. - 에폭시 페인트나 접착제를 사용할 때는 창문을 열어 환기를 시키고 화기를 멀리한다.
- 접착제를 사용할 곳과 사용하지 않는 곳에 주의하고 너무 많이 바르지 않도록 한다. - 시공 후 남은 부품은 어린 아이들의 손에 닿지 않도록 잘 처리한다.

#2182/F015

1

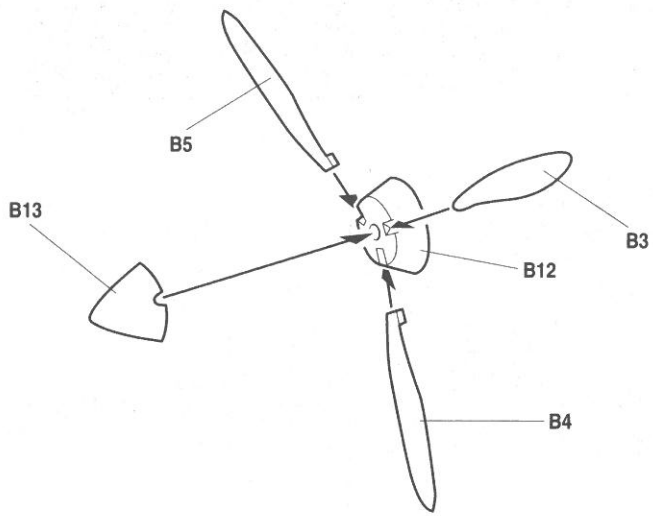

2

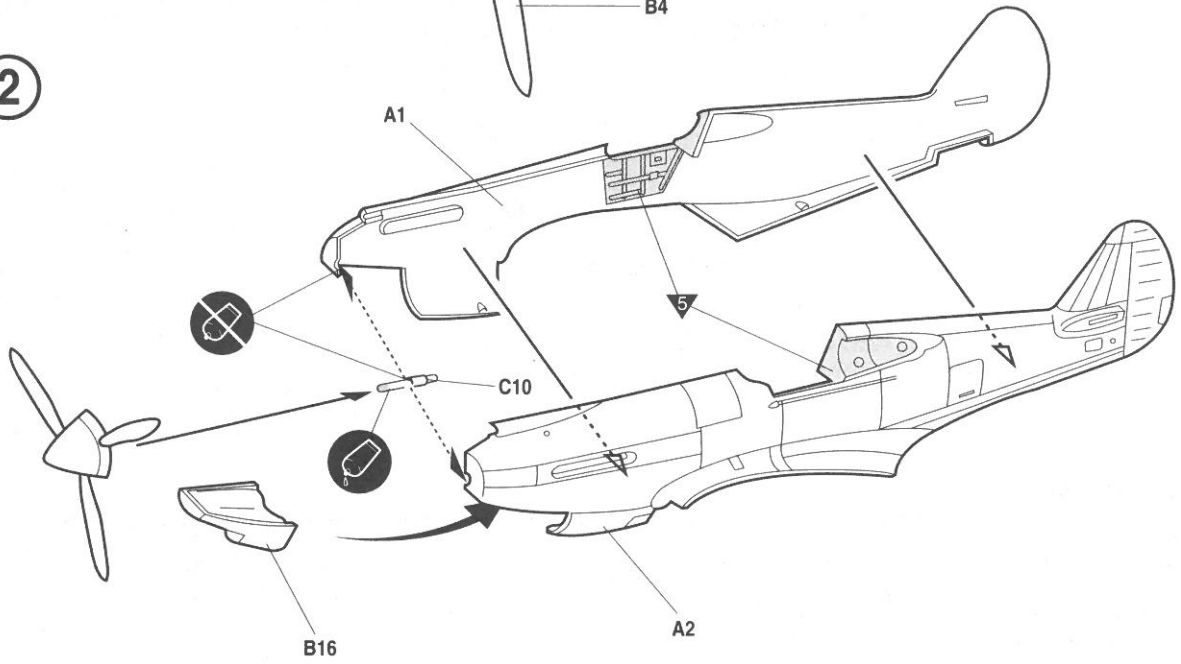

3

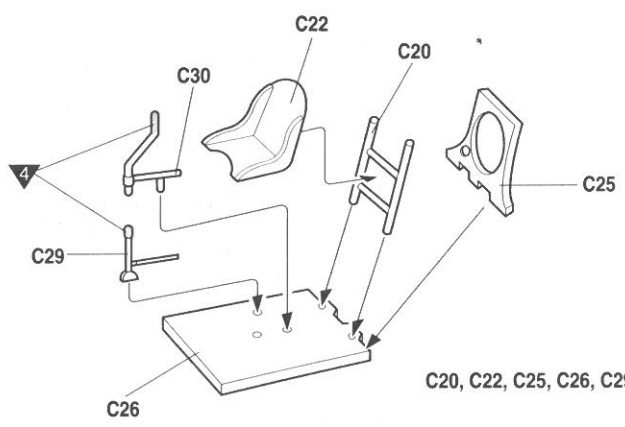

C20, C22, C25, C26, C29, C30: 5



점착제
Cement parts
Glue
Kleben
Pegar
Incollare
Colar
Kleven



점착제 사용 금지
Do not cement
Ne pas coller
Nicht kleben
No pegar
Non incollare
Nao colar
Niet kleven



반복 작업
Repeat operation
Répéter l'opération
Vorgang wiederholen
Repetir la operación
Repitire
Repita a operação
Herhalen



스티커를 붙이지 마세요
Do not stick
Ne pas coller
Nicht kleben
No pegar
Non incollare
Nao colar
Niet kleven



무게를 더하세요
Add weight
Lester
Gewicht



구멍을 뚫으세요
Make hole
Mastiquer
Schleifen



잘라주세요
Cut away
Couper
Schneiden
Cortar
Tagliare
Cortar
Snyden



선택 부품
Optional parts
Choix
Auswahlmöglichkeit
Elección
Scelta
Opcao
Keuze



반대쪽도 작업하세요
Repeat for opposite side
Répétition de la page
Wiederholung für gegenüberliegende Seite



구멍을 뚫어주세요
Make hole
Faire un trou
Öffnen



주의하세요
Be careful
Faire attention
Hier Vorsicht



색상 및 디자인 번호
Painting scheme number
Lackerschemanummer

4

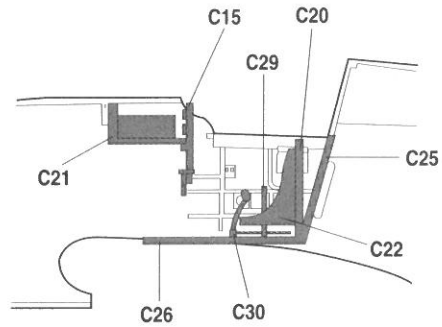
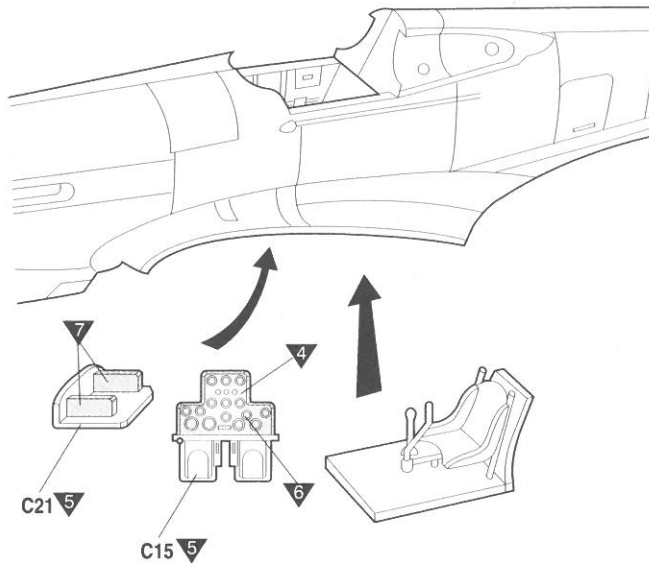

5

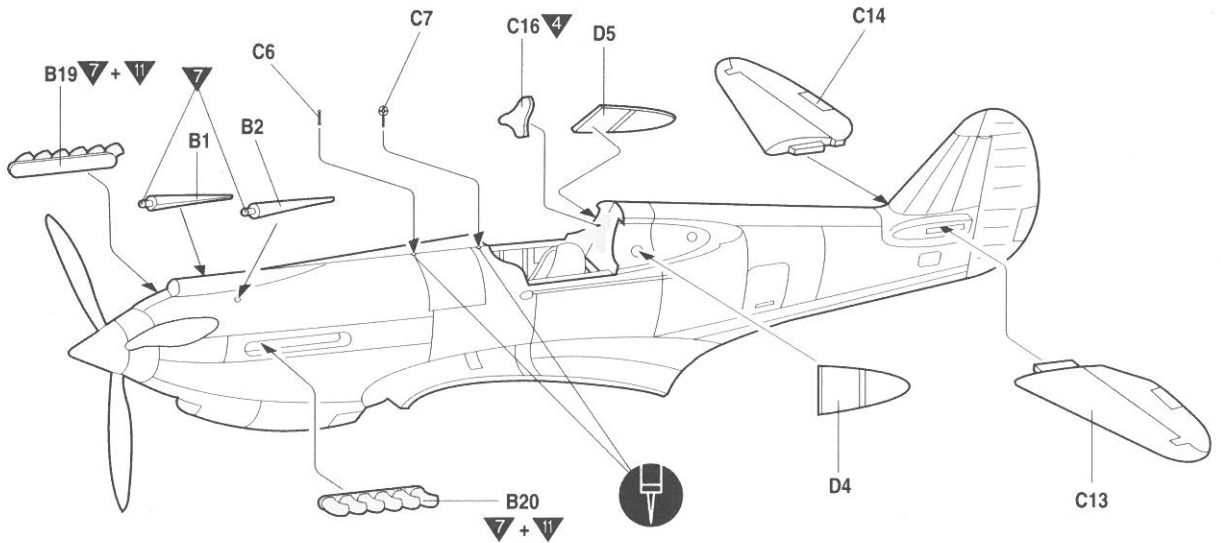

| | | | | | | | | | | | |
|---|--------------------------|-------------|-------------|----------|--------|---|------------------------------|-------------|-----------------|-----------|--------|
| 1 | DARK GREEN (FS 34092) | DUNKELGRÜN | VERT FONCÉ | ダークグリーン | 다크그린 | 5 | INTERIOR GREEN (FS 34151) | INNENGRÜN | VERT INTERIEUR | インテリアグリーン | 인테리어그린 |
| 2 | DARK EARTH (FS 30118) | ERDBRAUN | TERRE FONCÉ | ダークアース | 다크어스 | 6 | SILVER | SILBER | ARGENT | 실버 | 은색 |
| 3 | SKY GRAY (FS 36473) | HIMMELGRAU | GRIS CIEL | 스카이그레이 | 스카이그레이 | 7 | METALLIC GRAY | EISENFARBIG | GRIS MÉTALLIQUE | 메탈릭그레이 | 흑철색 |
| 4 | FLAT BLACK | MATTSCHWARZ | NOIR MAT | つや消しブラック | 무광검정색 | 8 | CLEAR RED | ROT,REIN | ROUGE CLAIR | 클리어레드 | 클리어레드 |

6

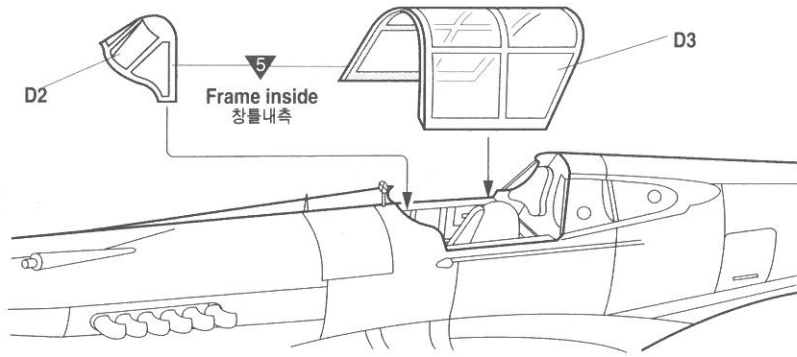

7

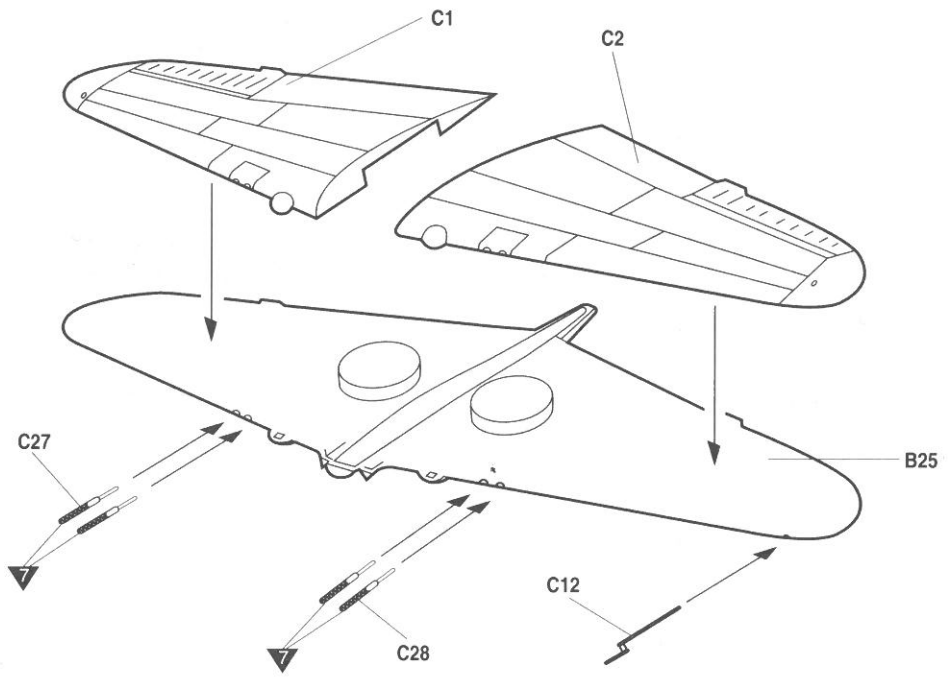

| | | | | | | | | | | | |
|----|----------------|--------------------|-------------|---------|-------|----|--------|------|-------|------|-------|
| 9 | CLEAR BLUE | BLAU, REIN | BLEU CLAIR | クリアーブルー | 클리어블루 | 13 | YELLOW | GELB | JAUNE | イエロー | 유광노랑색 |
| 10 | SEMGLOSS BLACK | SEDEINGLANZSCHWARZ | NOIR SATINÉ | 세미글로스블랙 | 반광검정색 | | | | | | |
| 11 | BROWN | BRAUN | BRUN | 브라운 | 갈색 | | | | | | |
| 12 | WHITE | WEIß | BLANC | 화이트 | 유광흰색 | | | | | | |

8

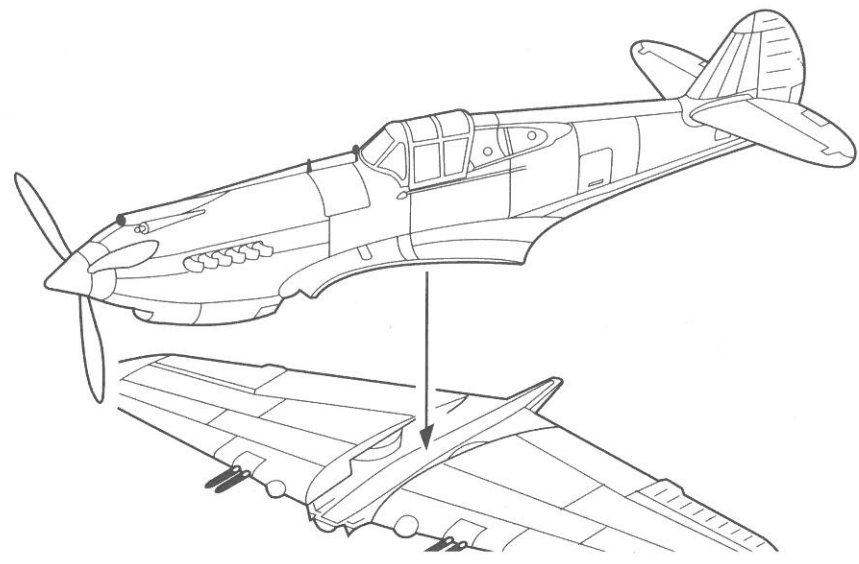

9



■ L/좌

■ R/우

- 1 : 12
- 2 : 6

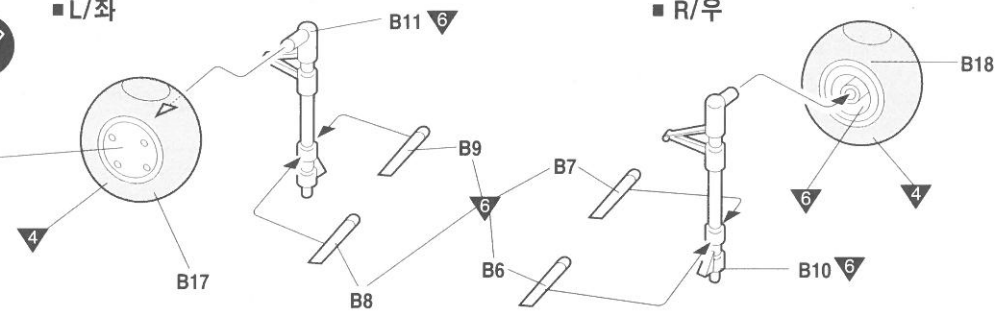

10



Inside
Innenseite
Intérieur
內側
내측면

Inside
Innenseite
Intérieur
內側
내측면

Inside
Innenseite
Intérieur
內側
내측면

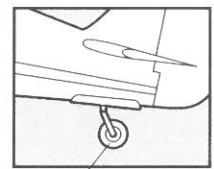

C18

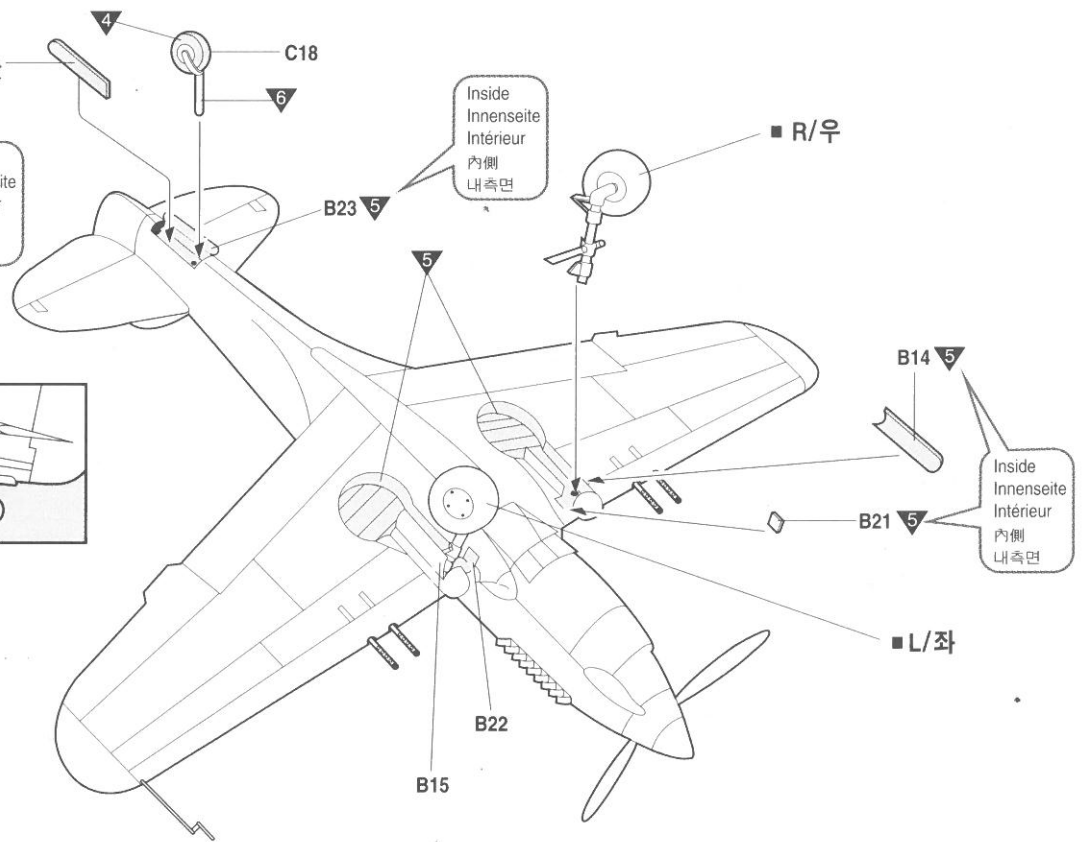

■ Painting & Decal placement 색칠 및 전사지 붙이기

I Curtiss Hawk 81-A2 (P-40C), flown by Squadron Leader Robert H. Neale, 1st PS "Adam and Eves", AVG, June 1942
 커티스 호크 81-A2(P-40C 토마호크), 미의용항공공부대 "플라이잉 타이거즈" 제 1추격 비행대 "아담과 이브" 지휘관 로버트 H. 니일 탑승기. 1942년 6월

1
 DARK GREEN(FS36032)
 다크그린

2
 DARK EARTH(FS30118)
 다크아스

3
 SKY GRAY(FS36073)
 스카이그레이

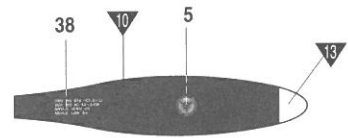
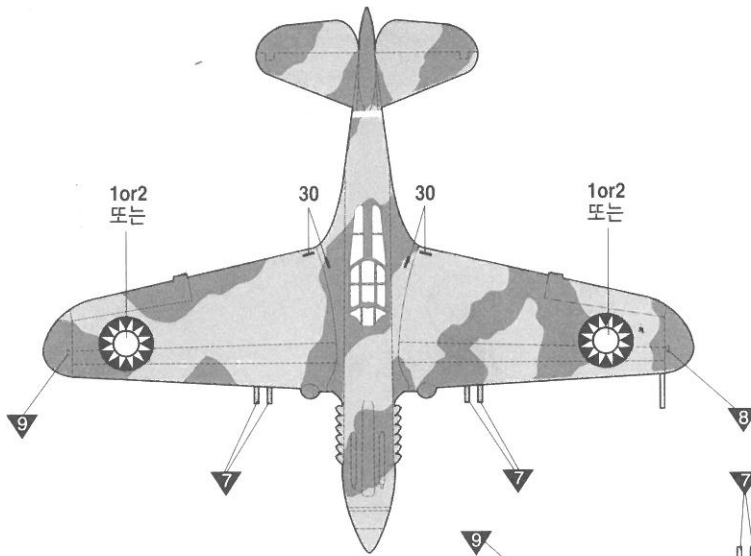
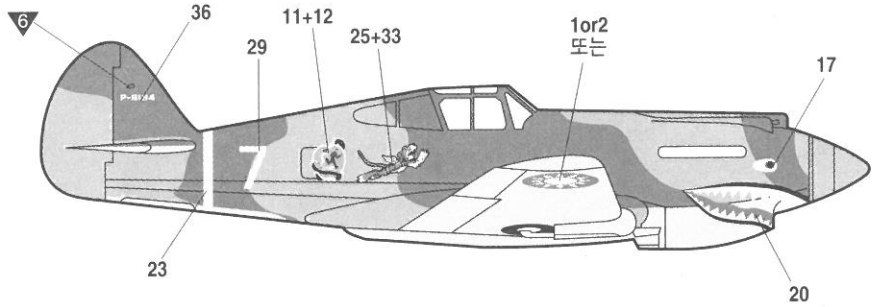
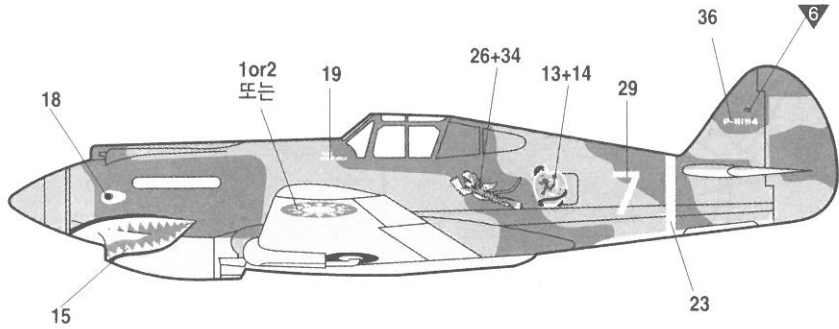

PROPELLER
 프로펠러



MAIN GEAR WHEEL
 주 기어 바퀴

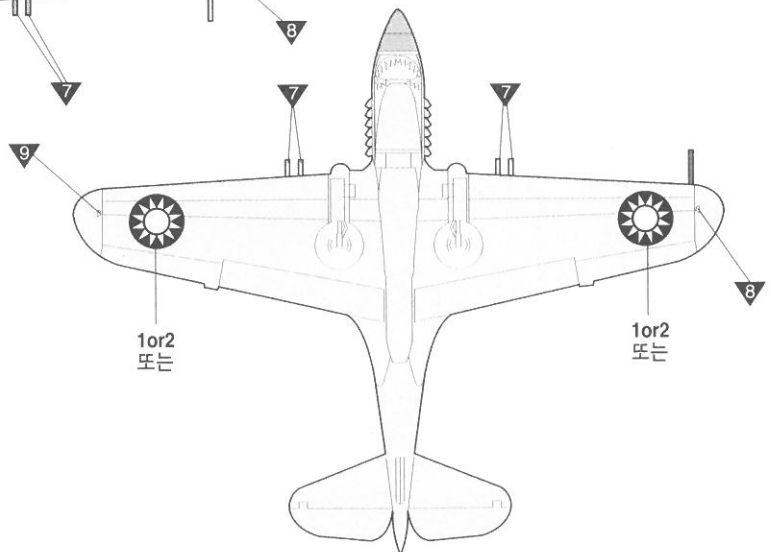

2 Curtiss Hawk 81-A2 (P-40C), flown by Charles Older, 3rd PS "Hell's Angels", AVG, May, 1942

커티스 호크 81-A2(P-40C 토마호크), 미의용항공부대 "플라잉 타이거즈" 제 3추격 비행대 "지옥의 천사" 소속 찰스 올더 탑승기. 1942년 5월



1
DARK GREEN(FS34092)
다크그린



2
DARK EARTH(FS30118)
다크어스



3
SKY GRAY(FS36473)
스카이그레이

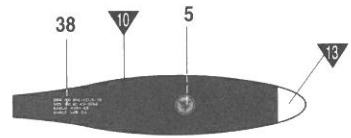
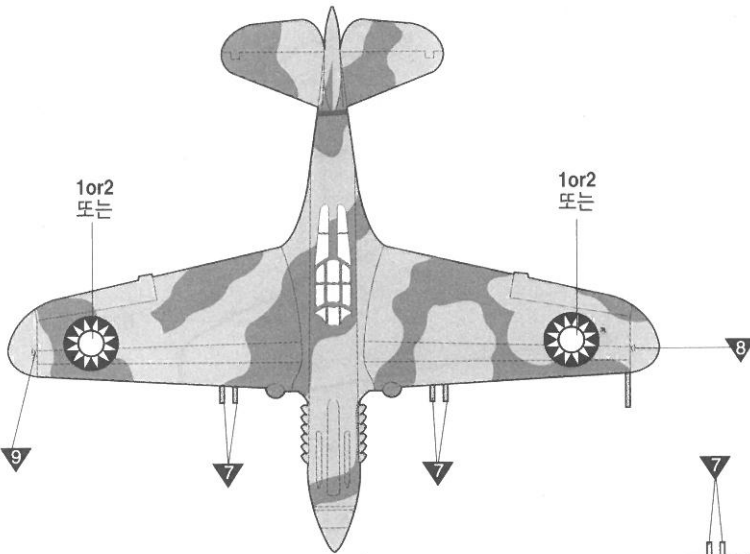
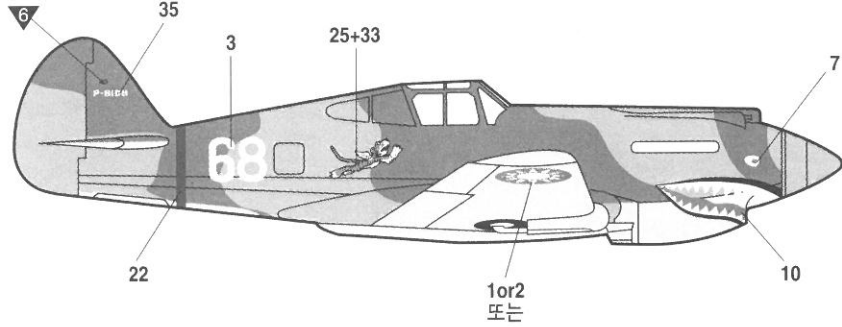
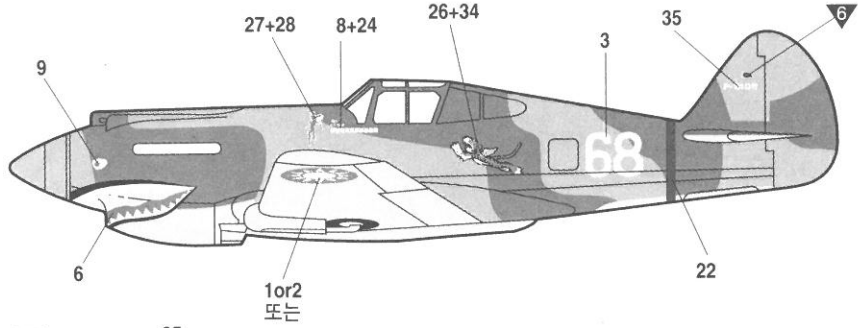

PROPELLER
프로펠러



MAIN GEAR WHEEL
주 기어 바퀴

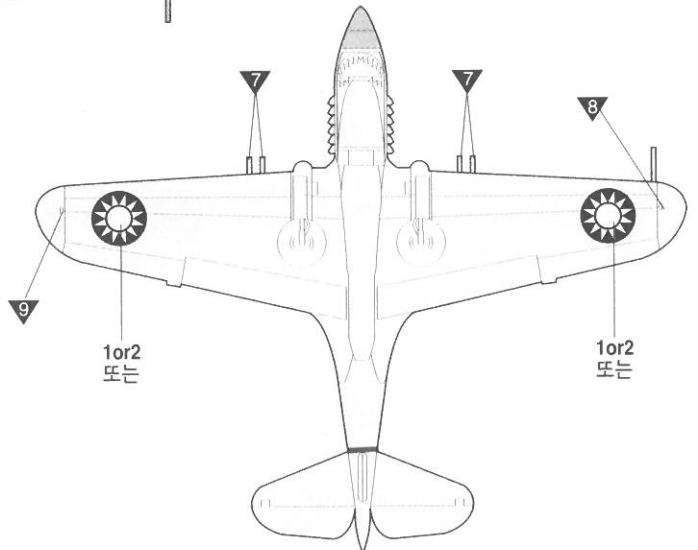

■ Parts Locating Diagram 부품도

A

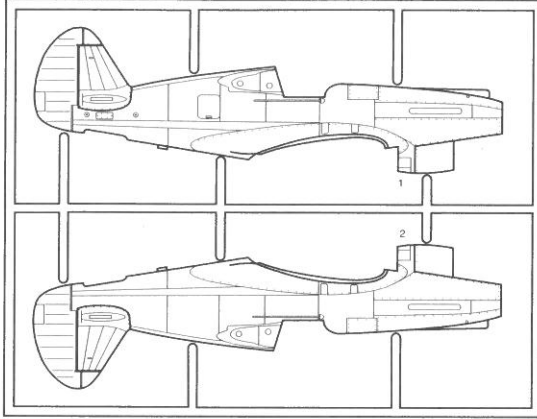

D

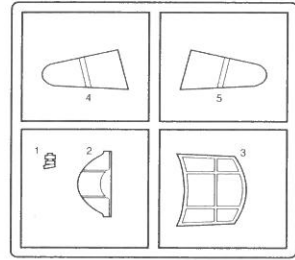

B

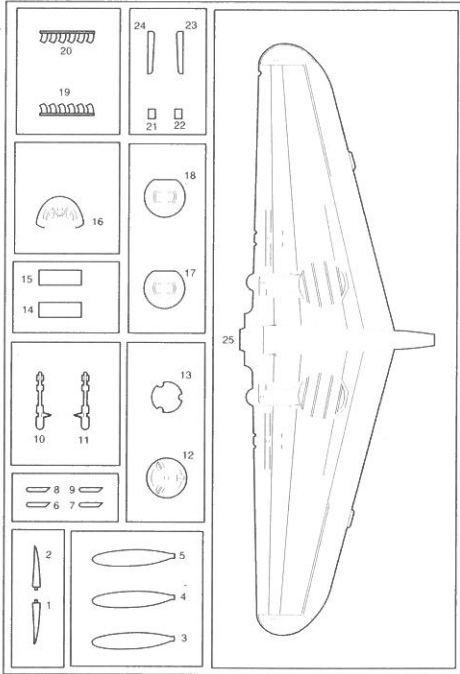

C

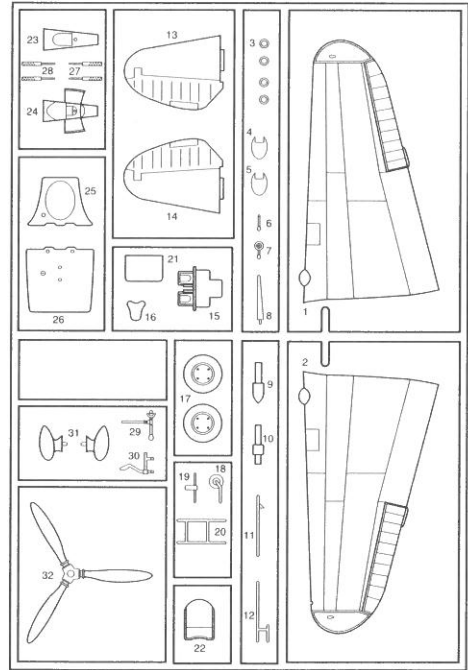

■ Unused parts

Nicht verwenden

Pièces non utilisées

不要部品

불필요 부품

C3, C4, C5, C8, C9, C11, C17, C19, C23, C24, C31, C32, D1

■ 직매점 겸 A/S센터 상선교:742-9293, 아셈학비센터:6002-8293, 학비관(용산전자랜드):701-4293
 ■ A/S센터 본사:908-7000(교훈147), 풍대문:745-8293, 관훈동:485-6884
 ■ 송문점 겸 A/S센터 강남아카데미:465-6884, 강북아카데미:782-0960, 강서아카데미:211-5200, 경남아카데미(창릉):055298-6940
 대구아카데미:053744-9293, 대구R/C:053741-8326, 서면아카데미:051818-9773, 서울아카데미:907-0940,
 아티(주):031527-8601, 강제아카데미:979-9997, 용산아카데미:796-1214, 용산R/C:711-0922
 http://www.academy.co.kr
 ■ 홈페이지 050-969-7000
 ■ 고객상담센터 소 서울시 강북구 수유 2동 273-64
 ■ 우

ACADEMY ACADEMY PLASTIC MODEL CO., LTD.
 HOBBY MODEL KITS 273-64, Suyu-dong, Kangbuk-gu, Seoul, Korea
 TEL:82-2-908-7000 FAX:82-2-997-3003

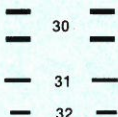
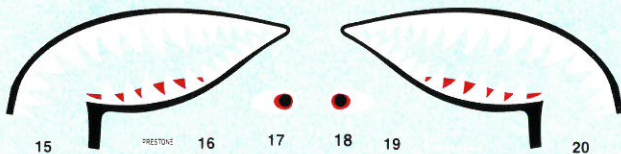
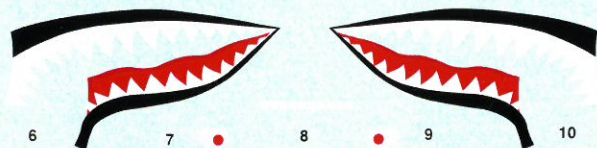
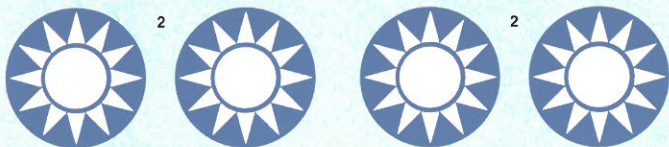

35

36

NO STEP 37

NO STEP

57511 57512 57513