

涂装同标贴指示 Painting & Marking guide

PAINT REFERENCE COLOUR

Color	Mr.Hobby	Vallejo	Model Master	Tamiya	Humbrol	Color	Mr.Hobby	Vallejo	Model Master	Tamiya	Humbrol
Light Green 绿色	H 303 303	-	1713	XF20	117	Clear Red 透明红	H 90 47	934	-	XF27	-
Sandy Brown 砂黄色	H 79 39	842	-	XF59	93	Flat Black 黑(哑光)	H 12 33	950	1749	XF1	33
Tire Black 胎黑色	H 77 137	-	-	-	-	Flesh 肤色	H 44 51	955	1516	XF15	61
Metal Black 黑铁色	H 18 28	864	1402	-	-	Yellow 黄色	H 4 4	953	1514	XF8	69
Yellow 黄色	H 313 313	819	1706	-	121	Yellow 白色	H 1 1	842	1745	X5	22

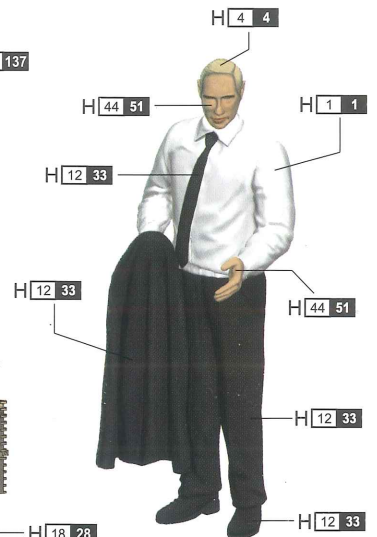

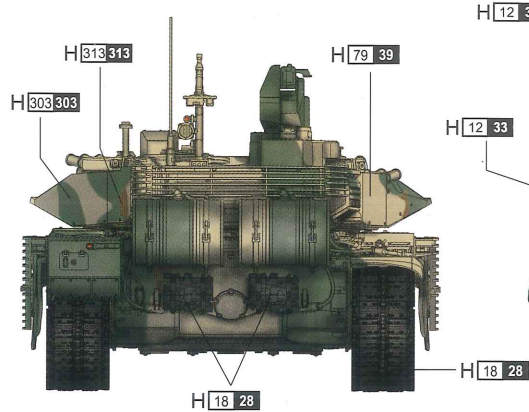
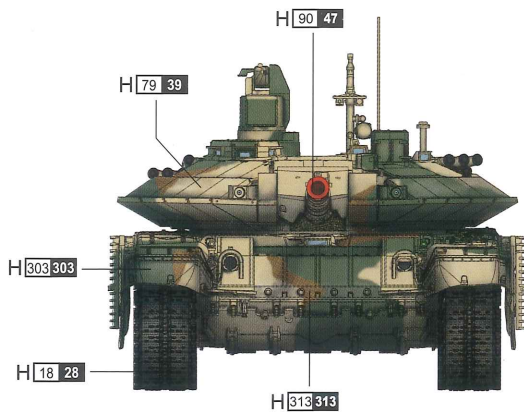
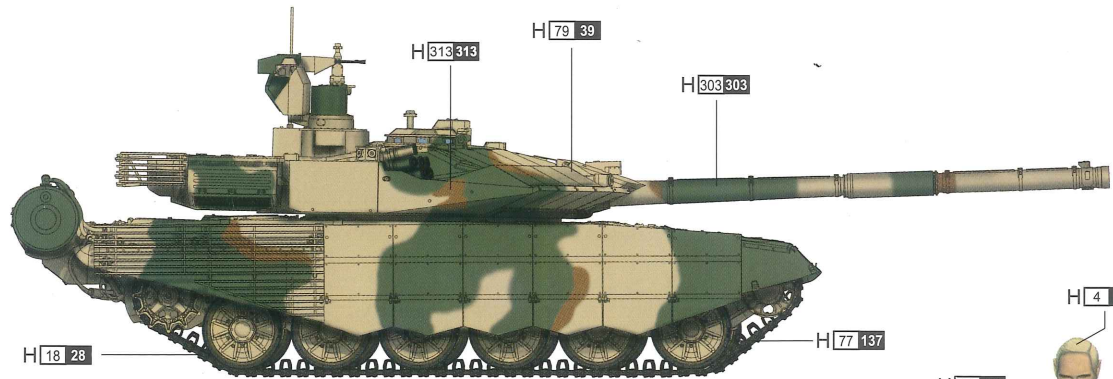
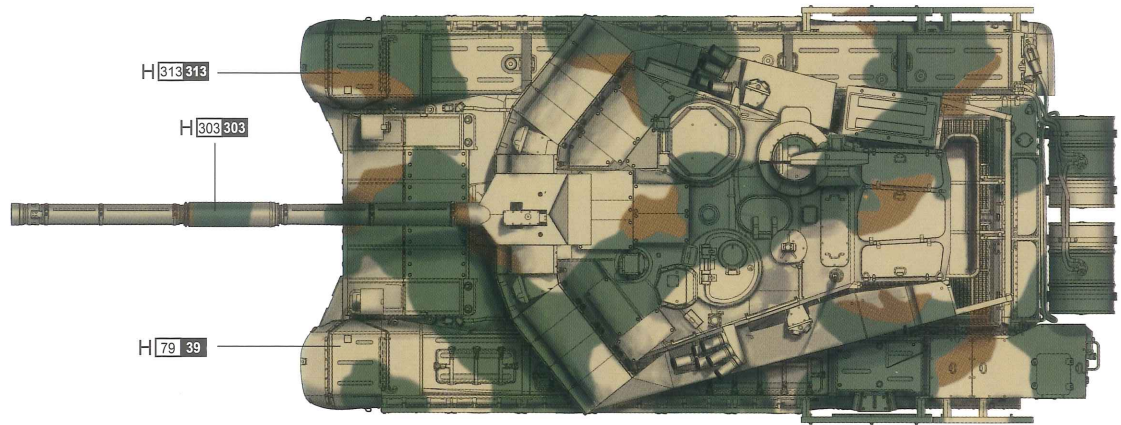
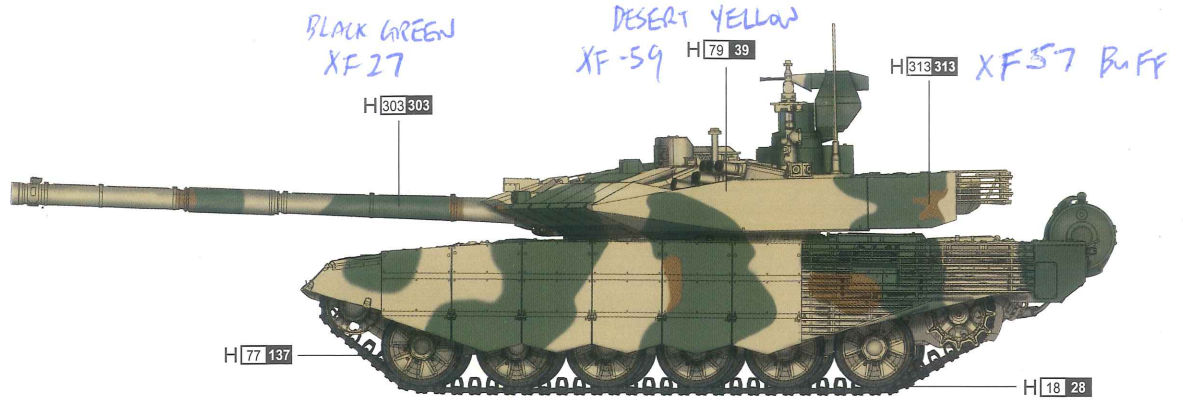
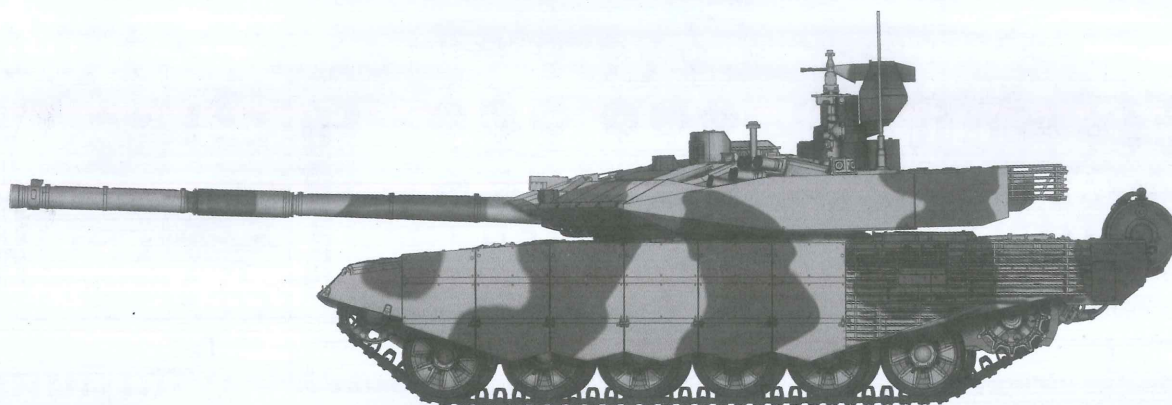

Russian T-90S Modernized

俄罗斯T-90S主战坦克(现代化升级)

READ BEFORE ASSEMBLY:

- Study and understand these instructions thoroughly before beginning assembly
- When needed, remove photo-etch parts carefully using a modeling knife or photo etch sprue cutter, being careful not to damage or lose small parts.
- Take extra care in handling photo etch parts in order to avoid injury
- Apply instant cement sparingly to photo etch parts where instructed
- Tools recommended(not included in kit):Plastic and instant cements, sprue cutters,long nose pliers,modeling knife, small files, tweezers, pin vise & scissors. Soft cloth and sandpaper will also assist in construction
- Glue and paint are not included in the kit. Use plastic cement and hobby paints only. Color guide for purchasing paint is included in the kit.

装配之前仔细阅读

- 小心用模型锉刀锉平所有零件表面的注射浇口。
- 小心用刀片切下蚀刻片零件，不要遗失小零件。
- 用强力快干胶水粘合蚀刻片零件和金属轴。过量快干胶水使用可能导致可动零件会粘住，小心涂胶。
- 取蚀刻片时应特别注意安全，防止利边划伤手指。
- 某些零件表面需贴水上贴纸，请选择在装配的同时进行。
- 推荐模型工具(自备)：胶水，水口剪刀，长咀钳，刀片，锉刀，镊子，钳，钻，剪刀，瞬间快干胶。
- 软布同砂纸同时也应该是必备工具。
- 请使用塑料胶水和油漆，模型内不含。



配重
Weight



使用强力胶
Cyanoacrylate glue



钻孔
Make hole



切除
Cut / Remove



贴纸
Decal



锉平
File / Sand



选择
Option



不涂胶水
No cement



弯曲
Bend

水贴纸的使用:

- 1.从水贴纸上剪下印花;
- 2.将印花放入温水中浸10秒, 然后放在干净布上。
- 3.拿着印花纸板将印花移到模型上;
- 4.手指蘸水将印花移到适当的位置;
- 5.用软布轻压印花直至水干, 气泡消失

DECAL APPLICATION

- 1.Cut decals from sheet as needed
- 2.Dip the decal in warm water for about 10 seconds and then place on soft clean cloth.
- 3.Hold the decal backing sheet edge and gently slide the decal onto the model in its proper position.

- 4.While still wet,decal can be adjusted for better fit on model by dampening it gently with your finger.
- 5.When placed in the proper position,gently press decal down with a soft cloth until excess water and air bubbles are gone.
- 6.Allow decal to dry completely before handling model

部品图 Parts

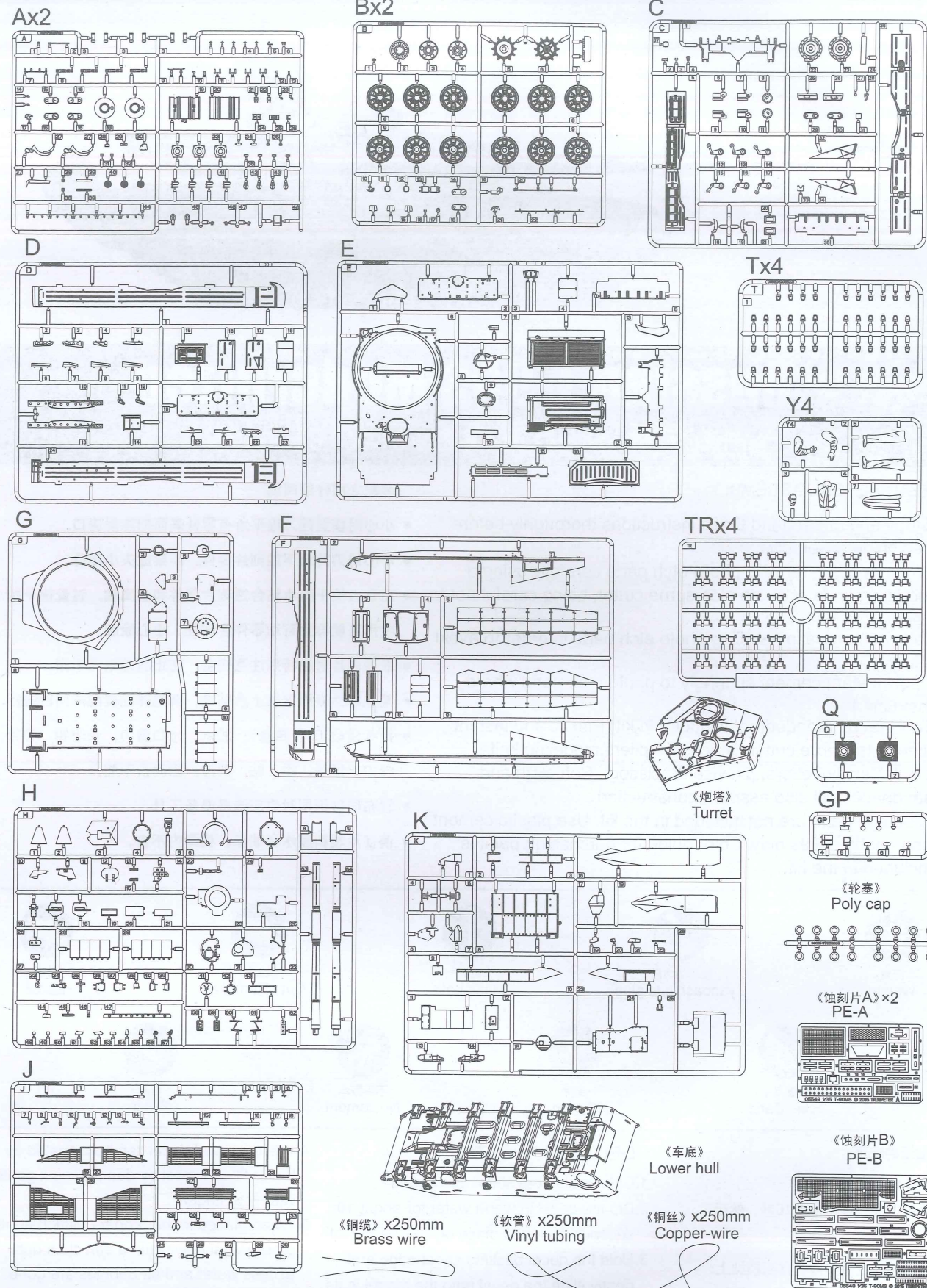

不用部品: C1 C2 C3 C4 C20 C21 C24 C25 C27 C31 C35 D2 D3 D15 D16 D19 D20 D24 H55 H58 H59 J4 J19 J20 G8
Unused parts

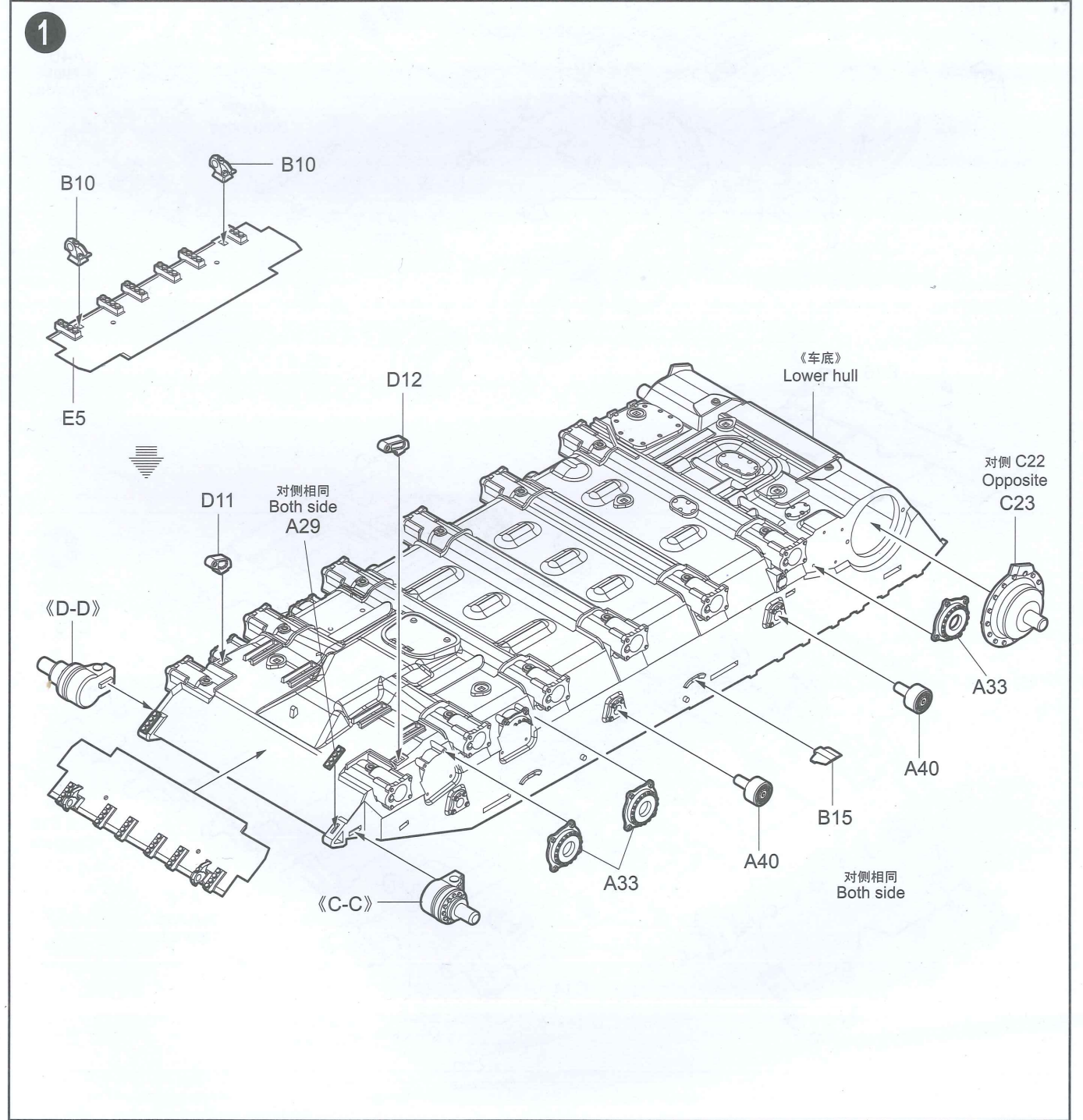
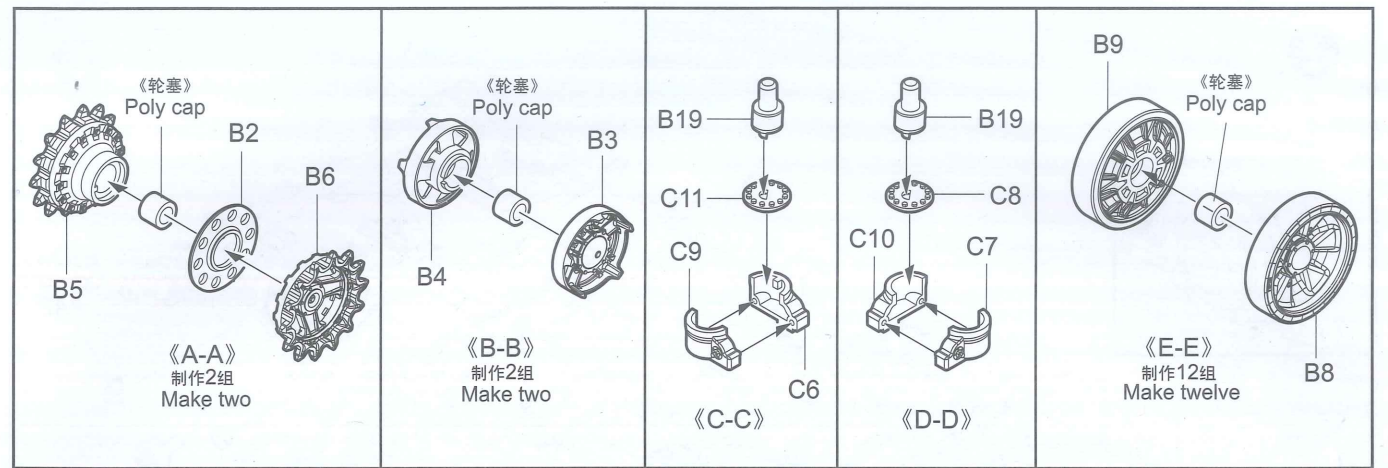

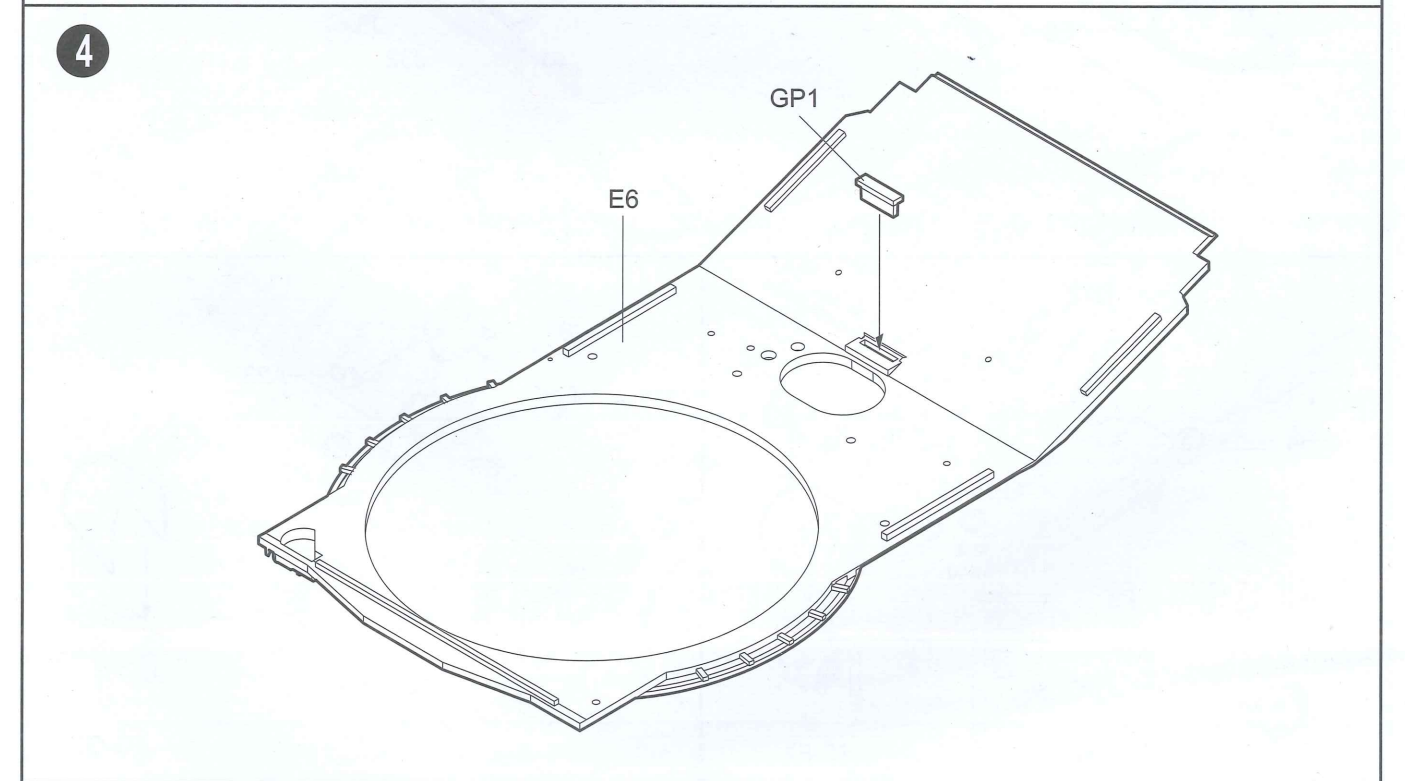
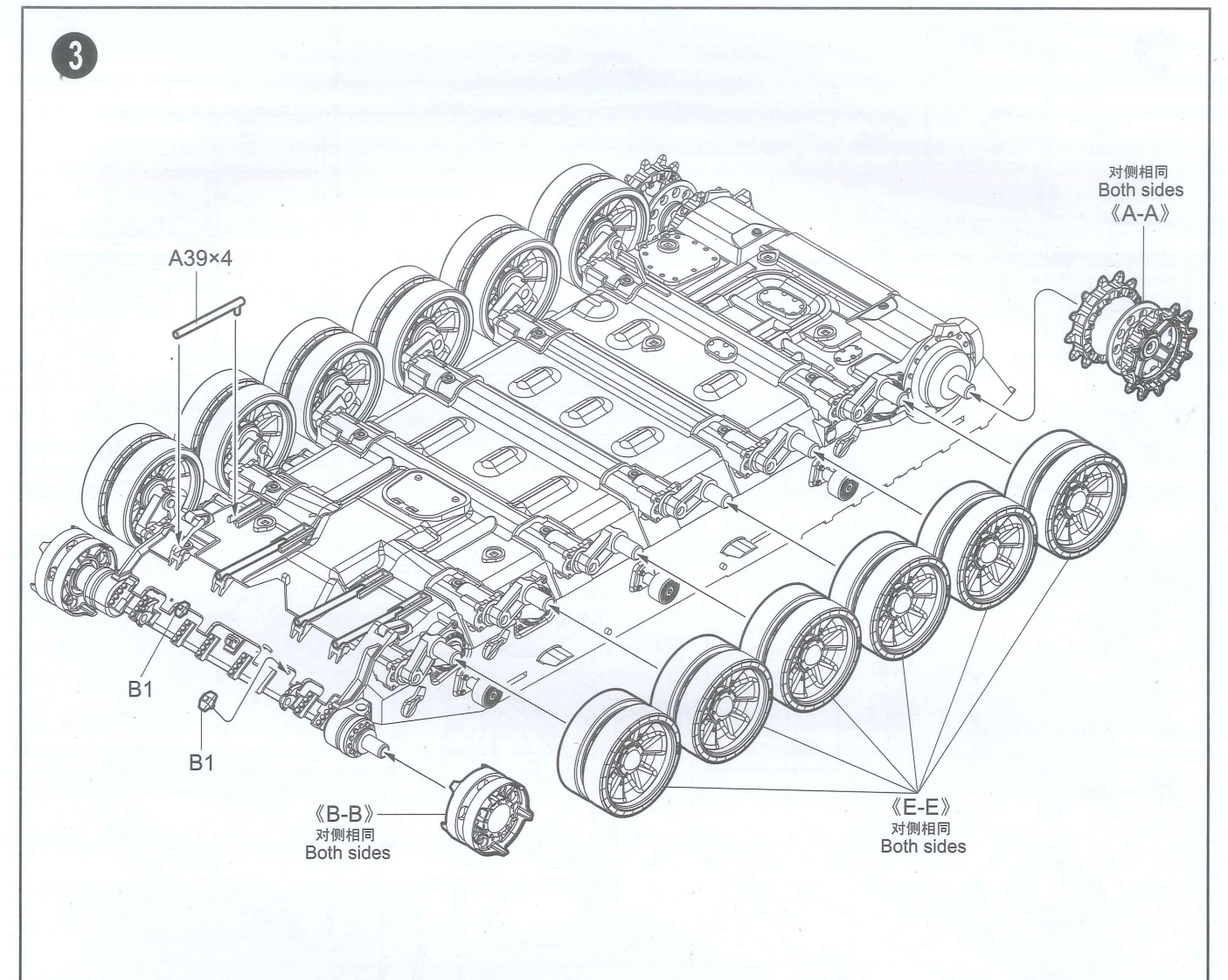
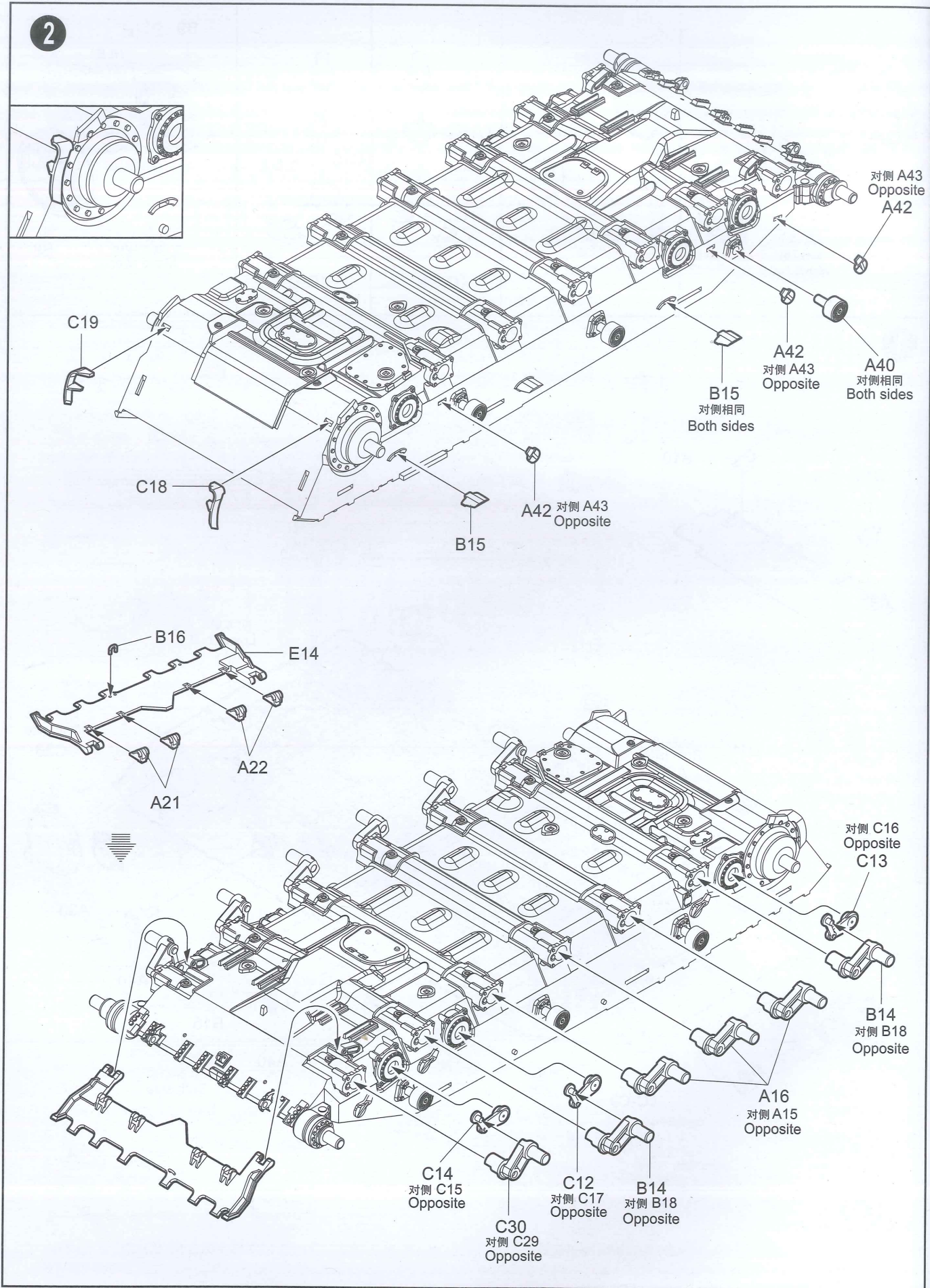

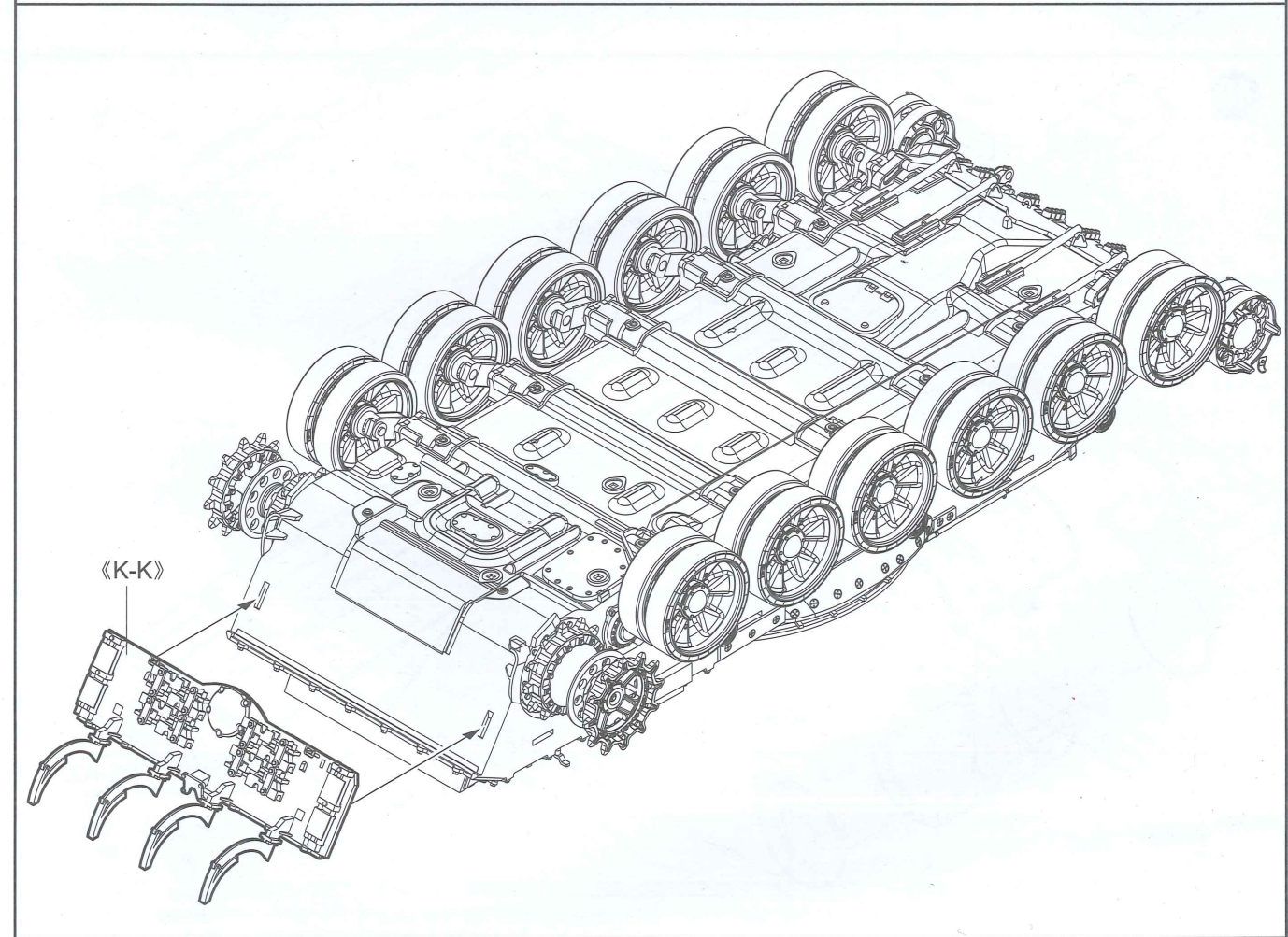
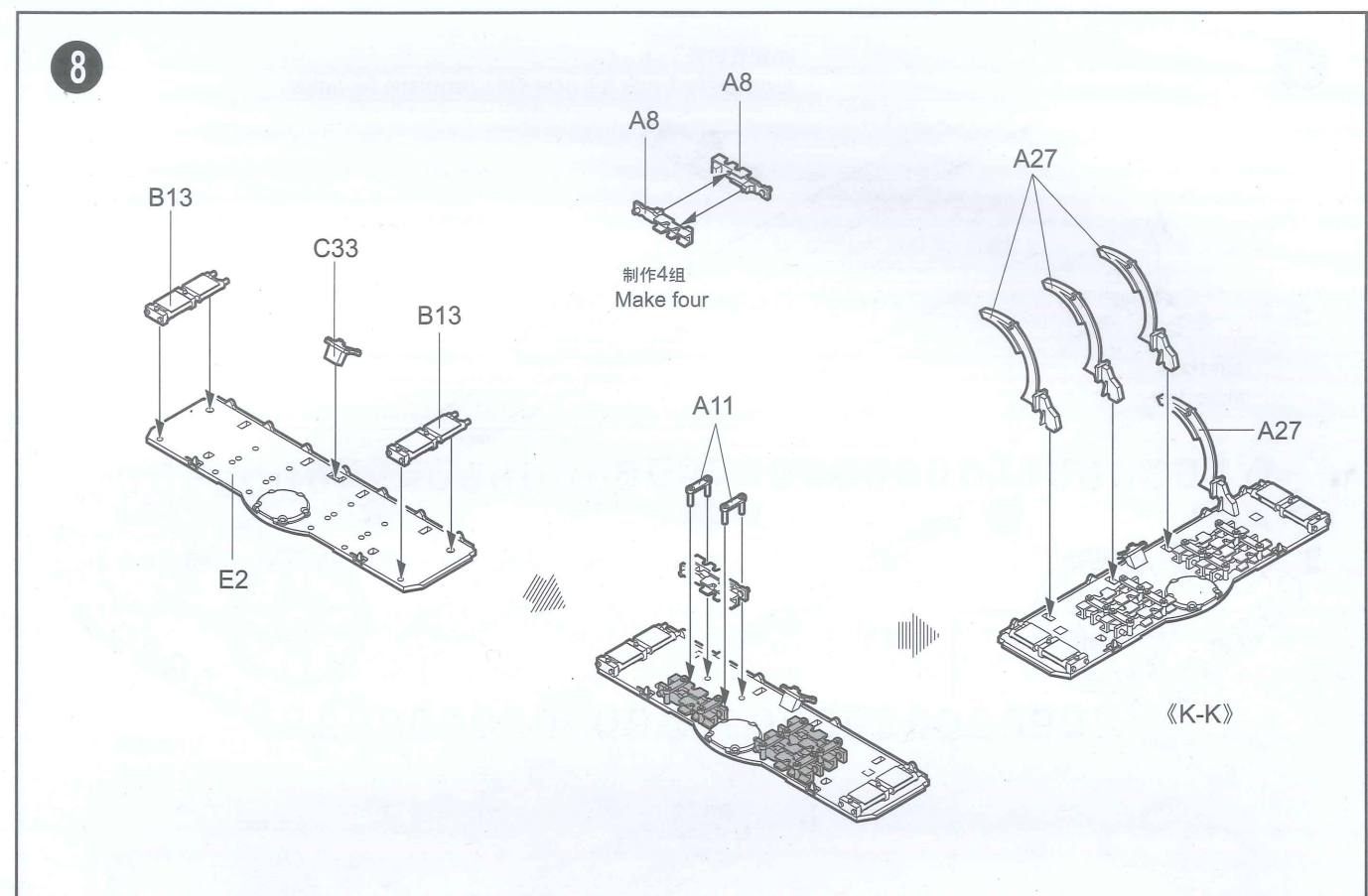
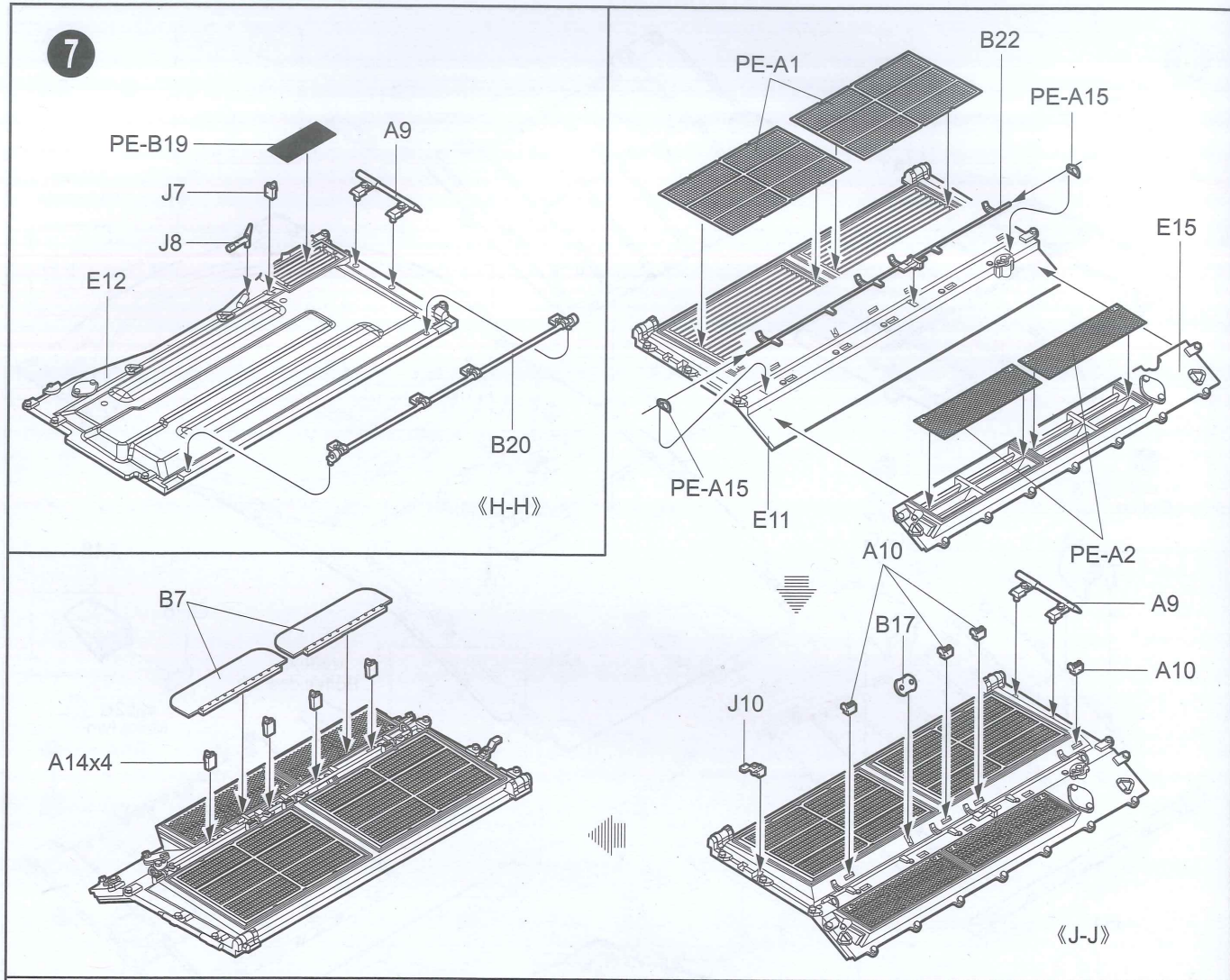

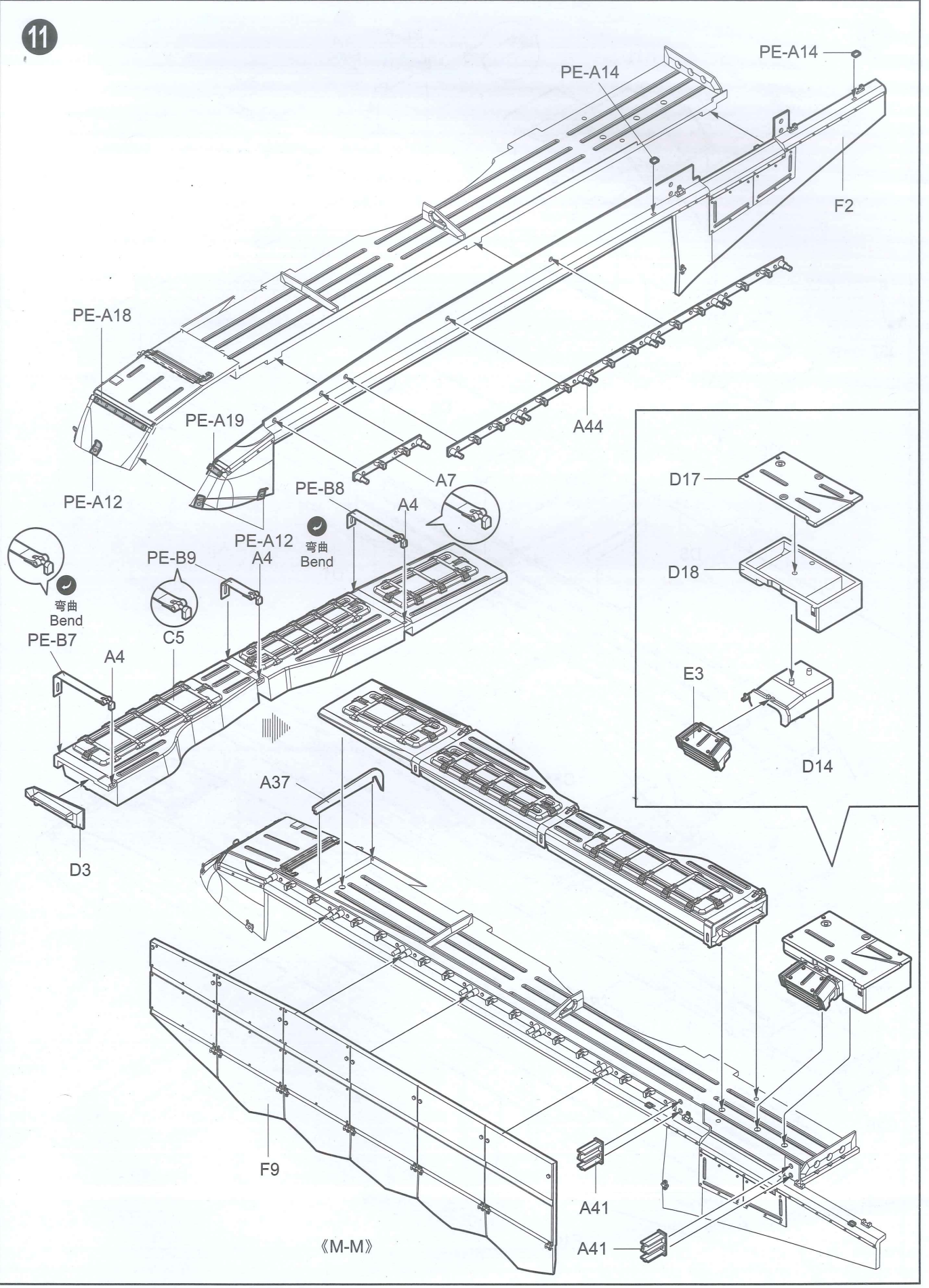
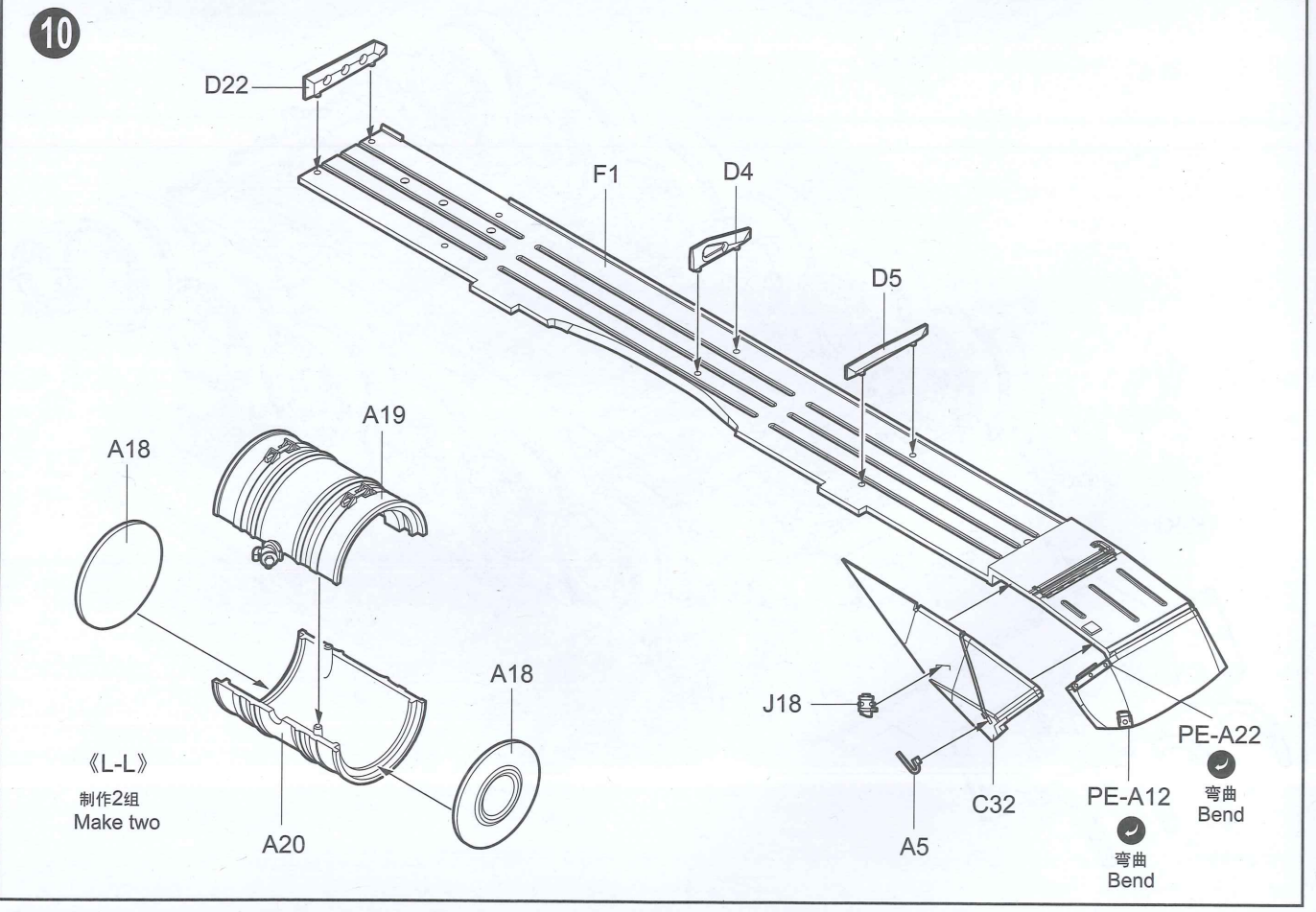
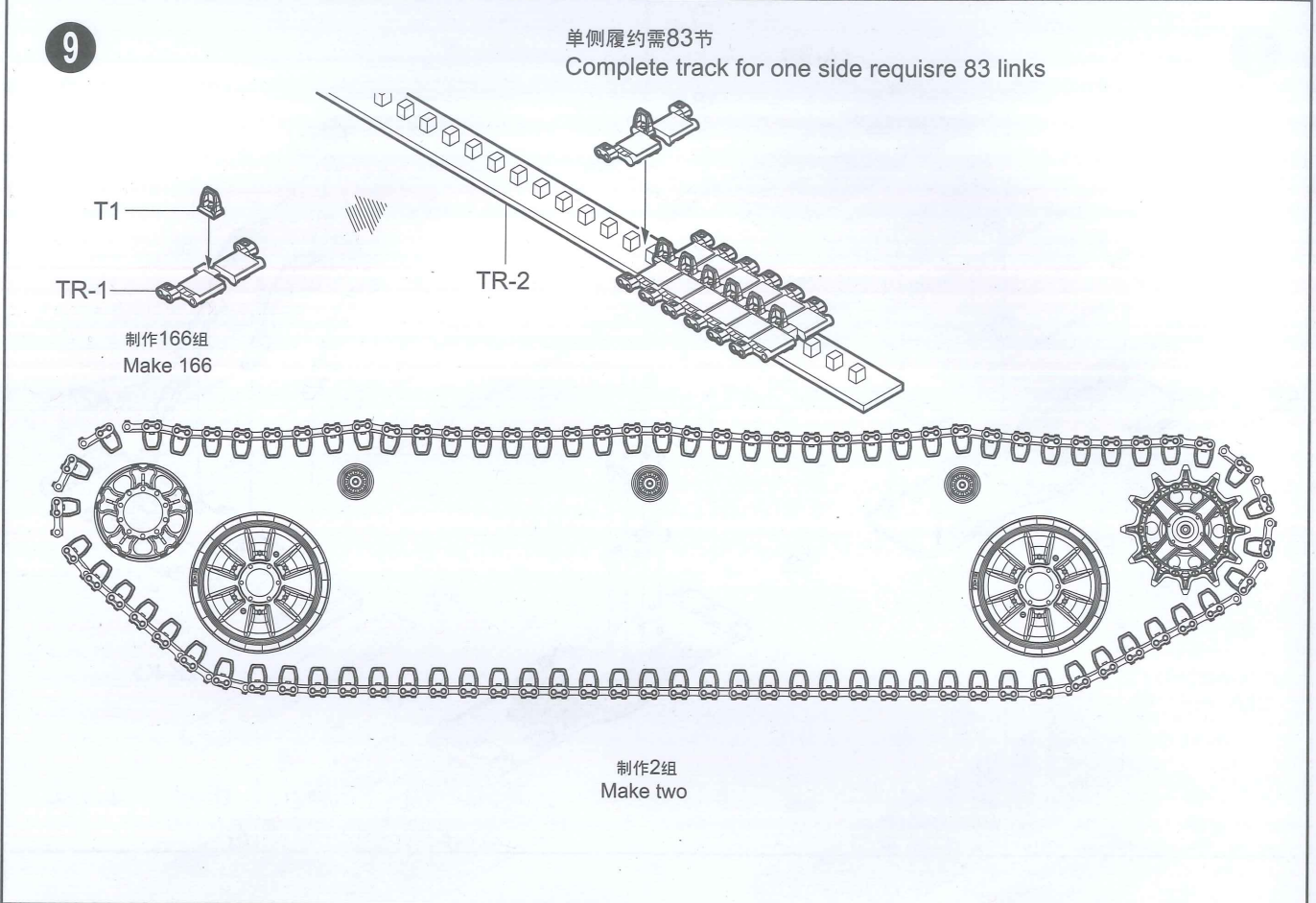

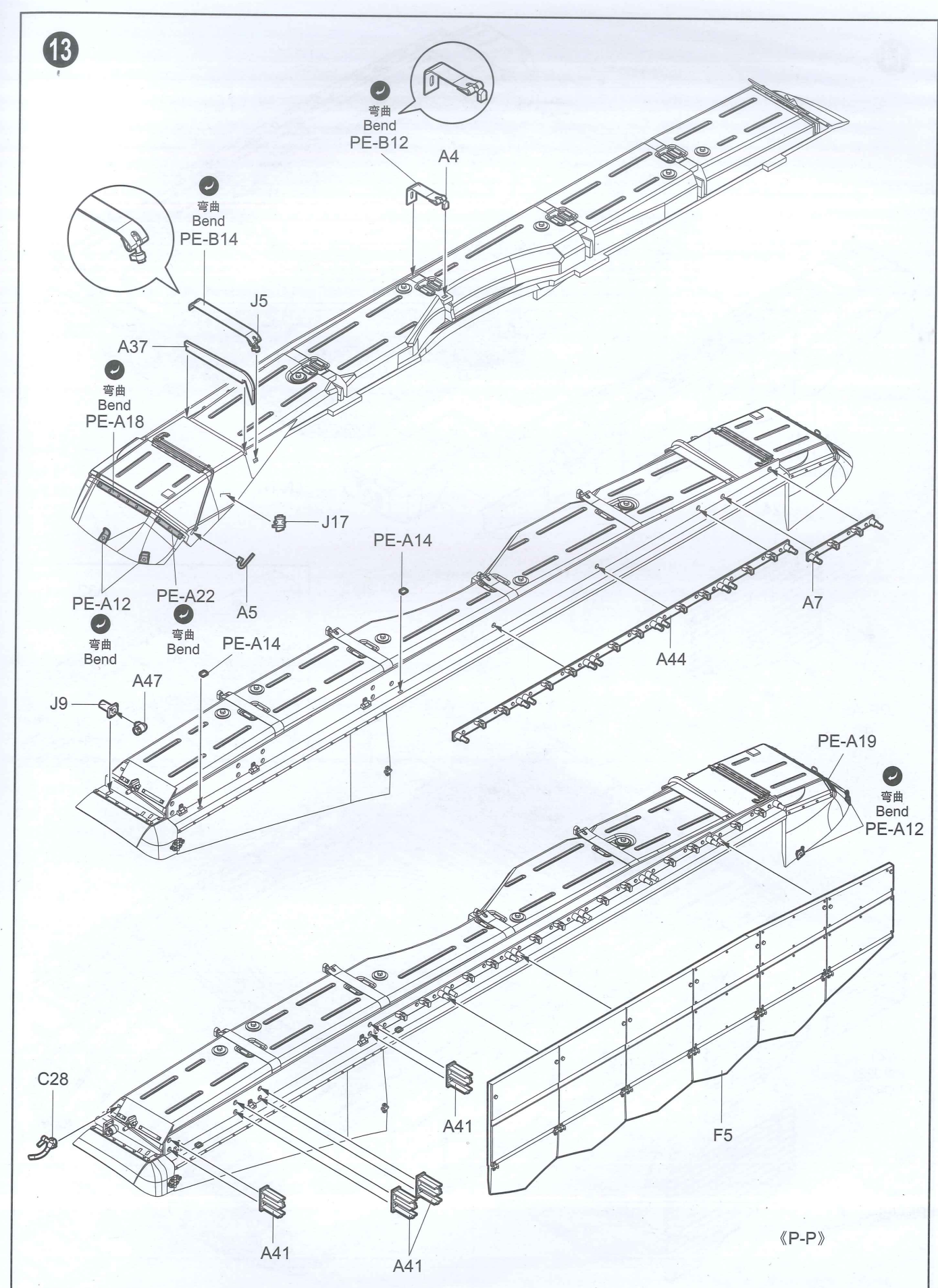
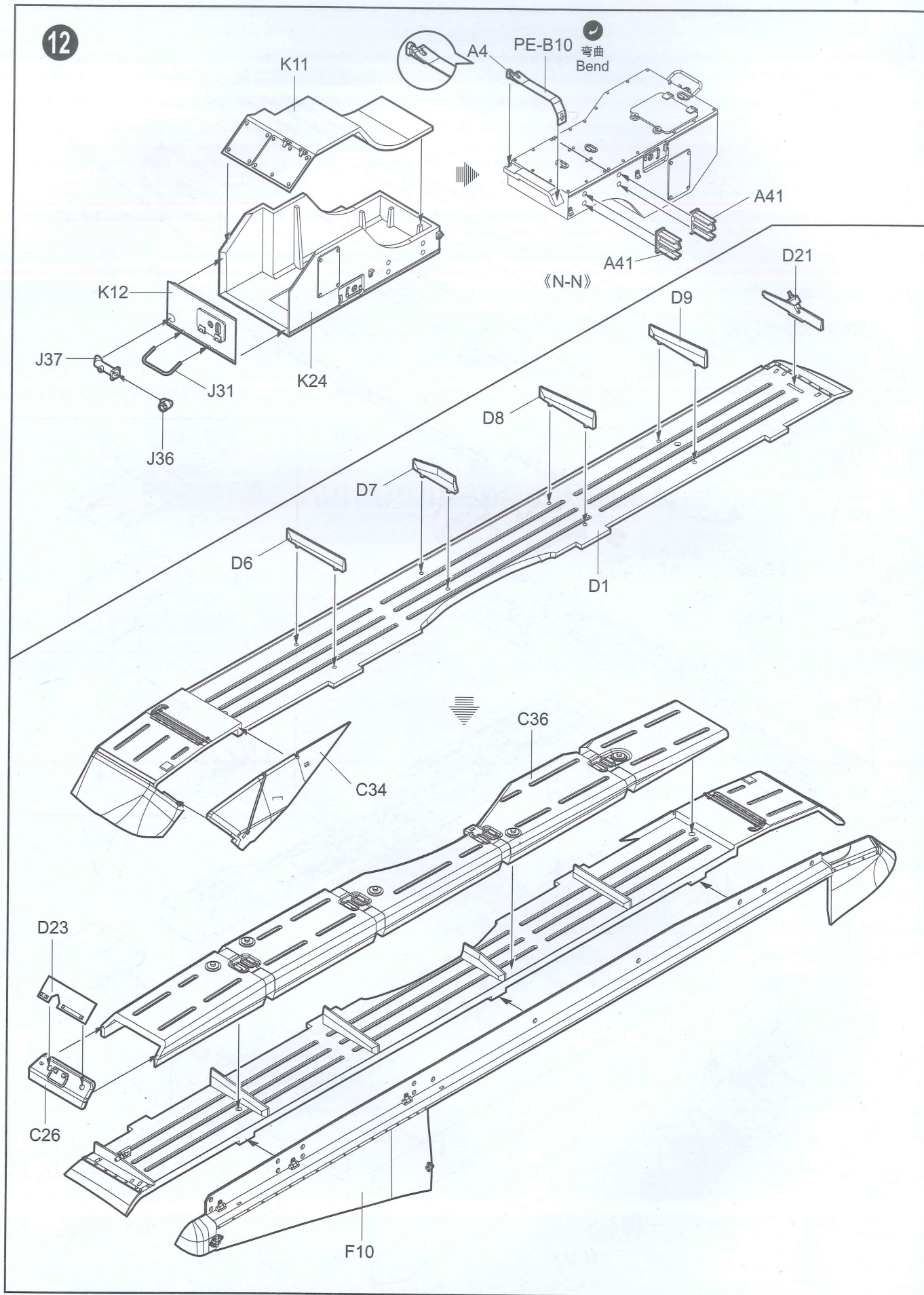

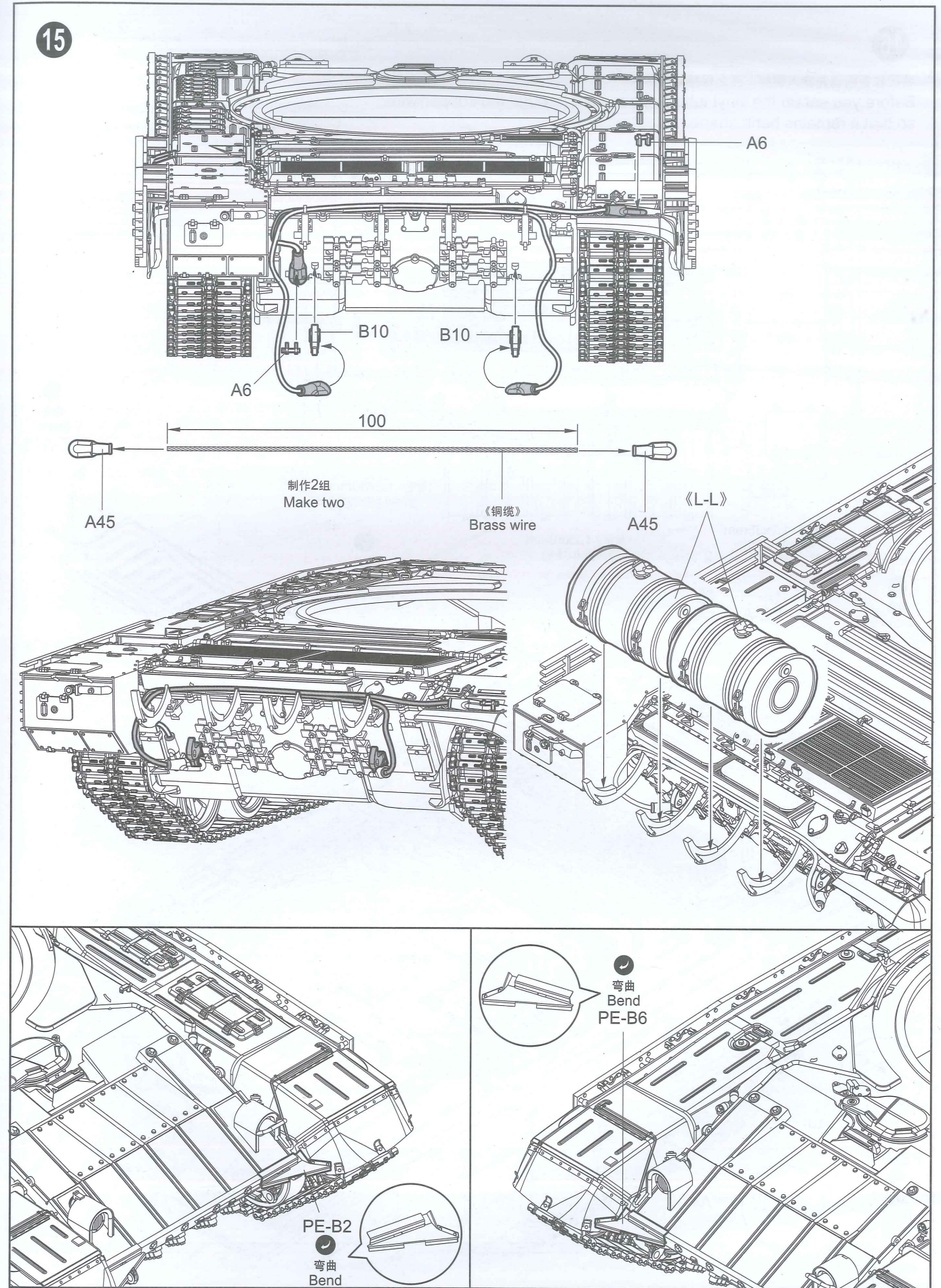
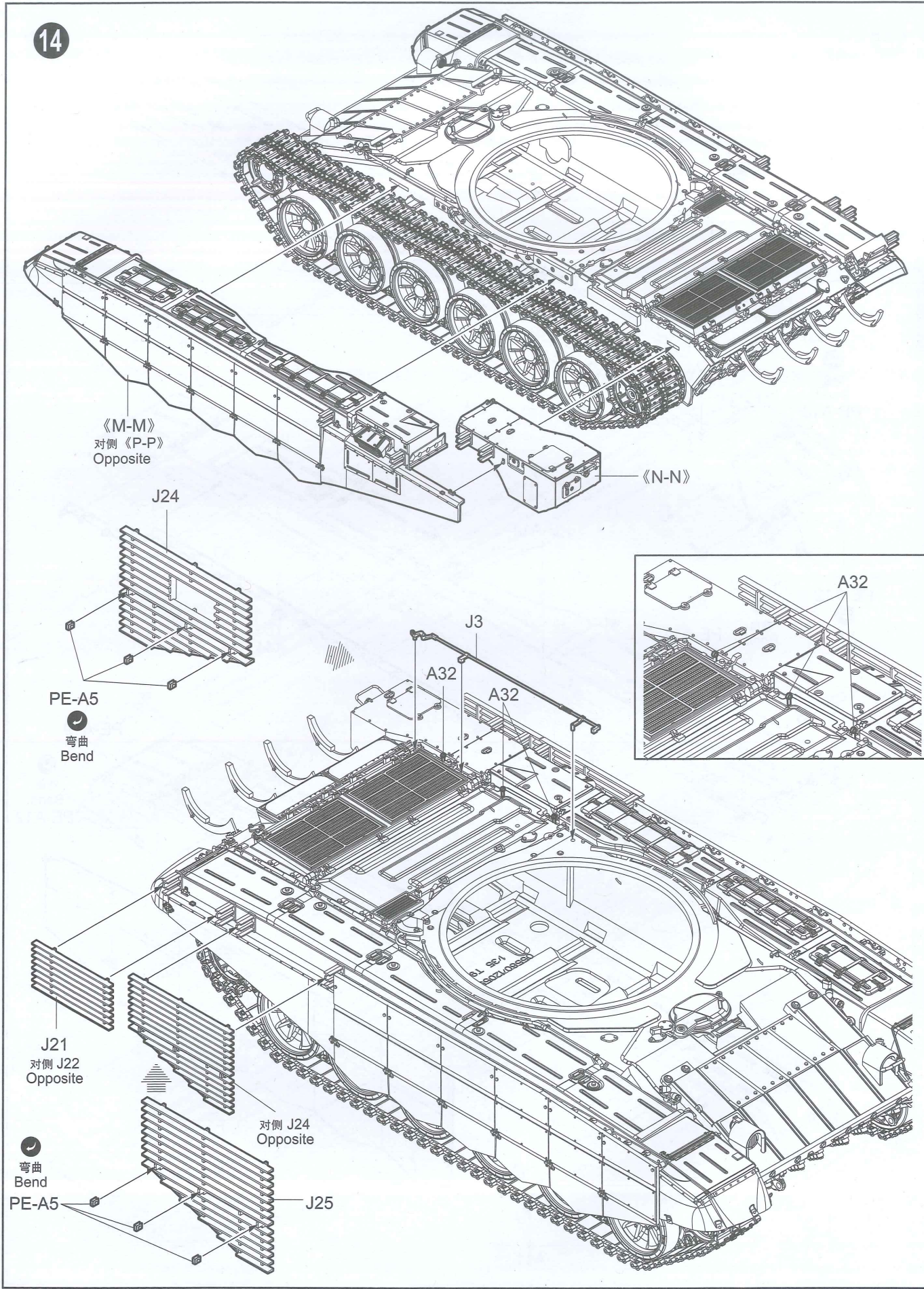

16

装配软管前请先穿入铜丝，使之保持弯曲形状。
Before you set up the vinyl tubing, please get through the copper-wire, so that it remains bend shape.

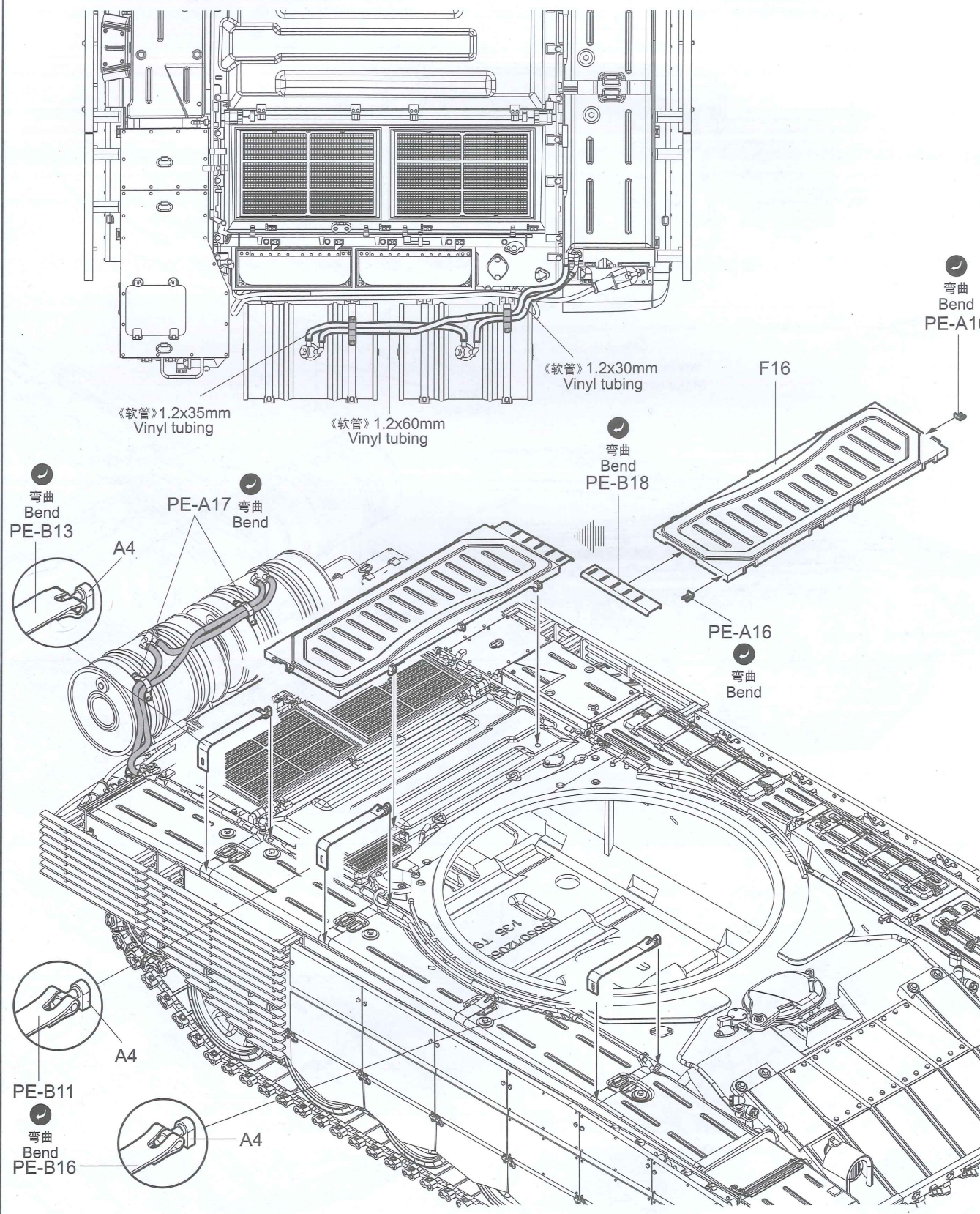
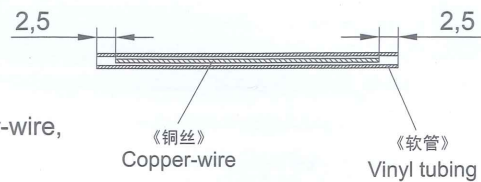

17

