

ACADEMY
HOBBY MODEL KITS

P-26A/C PEASHOOTER

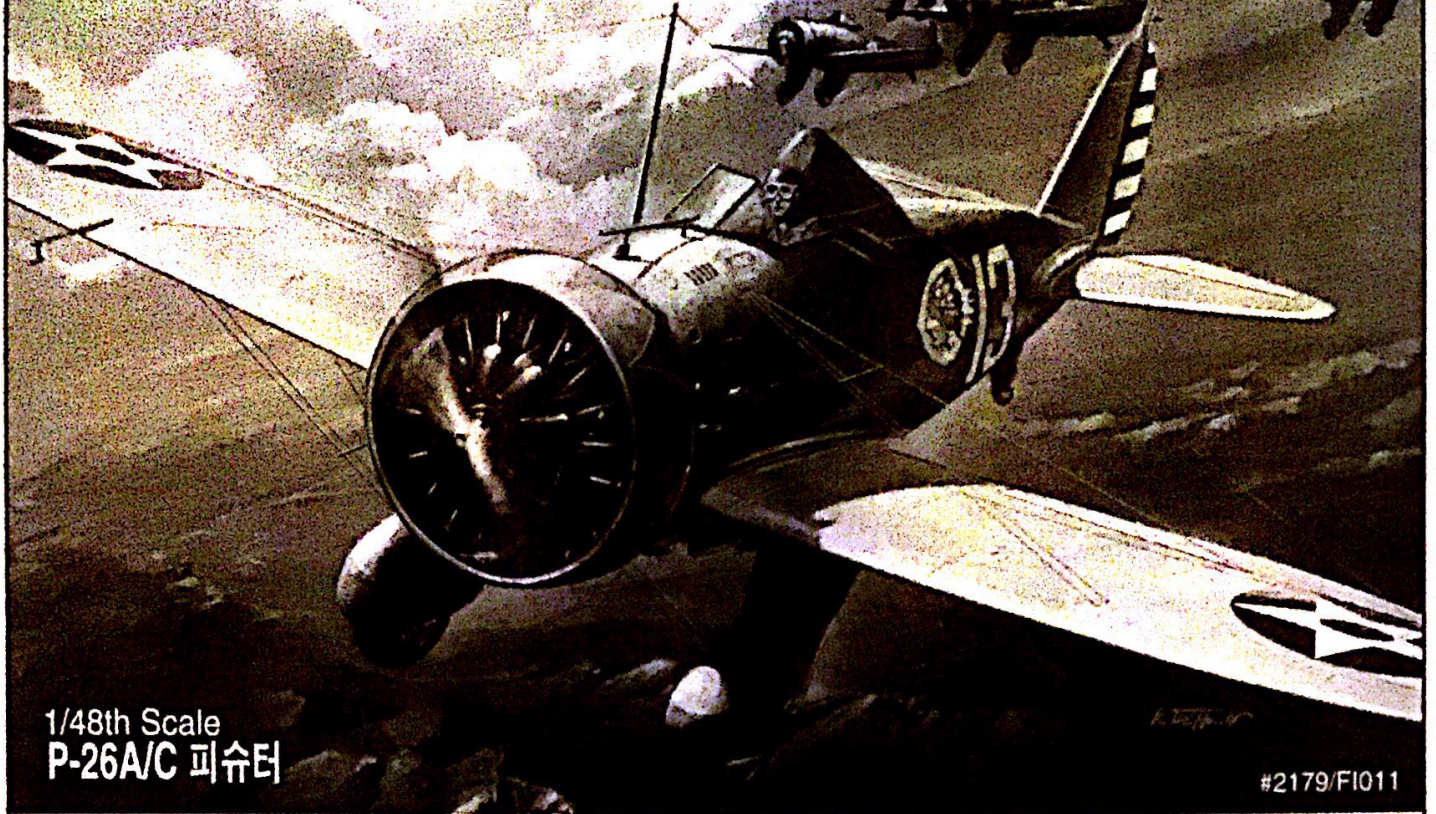

1/48th Scale
P-26A/C 피슈터

#2179/FI011

<P-26A SPECIFICATION>

LENGTH: 7.17m
WINGSPAN: 8.5m
HEIGHT: 3.05m
EMPTY WEIGHT: 996kg
MAX.WEIGHT: 1,358kg
POWERPLANT: Pratt & Whitney R-1340-27
air cooled engine x 1(525hp)
MAX.SPEED: 377km/h
SERVICE CEILING: 8,350m
RANGE: 1,020km
ARMAMENT: Two .30 caliber machine gun
plus two 100-lb or five 30-lb bombs

<P-26A형 주요 제원>

전장: 7.17m
전폭: 8.5m
전고: 3.05m
기체중량: 996kg
최대 이륙 중량: 1,358kg
동력원: 프랫 앤드 휘트니 R-1340-27
공냉식 엔진(525마력)
최대 속도: 시속377km/h
실용 상승 한도: 8,350m
항속거리: 1,020km
무장: 캘리버30 기관총(구경7.62mm)2문 외
2발의 45kg 또는 5발의 13.6kg폭탄 탑재가능

<READ THIS BEFORE YOU BEGIN>

- Study the instructions before assembling. - Check the fit of each piece before cementing into place.
- Do not use too much cement to join parts. - Never use cement or paint near open flame.
- Open a window or make area well ventilated when cement or paint is in use.
- Tear up and throw away the empty plastic bags to avoid danger of suffocation for little children.

<ALLGEMEINE HINWEISE>

- Die Anordnung der Bauteile ist aus den Zeichnungen der Anleitung ersichtlich.
- Die Teile vor dem Verleimen ungleichmäßig zusammenstellen, um ihnen perfekt zu prüfen.
- Klebstoff nicht zu dick auftragen. - Klebstoff und Farben niemals in der Nähe einer Flamme verwenden.
- Während der Bemalung mit Spritzpistole oder Pinsel für frische Luftzufuhr, z.B. öffnen des Fensters, sorgen.
- Bauzeit von kleinen Kindern fernhalten. Verhüten Sie, daß Kinder irgendwelche Bauteile in den Mund nehmen oder Plastikfolien über den Kopf ziehen.

※조립하기 전에

- 부품을 조립하기 전에 설명서를 잘 읽어본 후 조립한다.
- 접착제나 페인트나 염색제를 사용할 때는 장갑을 얹어 화기를 사용하고 화기를 멀리한다.

부품을 지를 때에는 밑이나 나뭇잎이 깔려있다.

에어캡 확인이나 염색제를 사용할 때는 장갑을 얹어 화기를 사용하고 화기를 멀리한다.

- 접착제를 사용할 곳과 사용하지 않는 곳을 주의하고 너무 많이 바르지 않도록 한다.
- 사용 후 남은 부품은 어린 아이들의 손에 닿지 않도록 잘 치러낸다.

<LISEZ CE QUI SUIT AVANT DE COMMENCER LE MONTAGE>

- Etudier les schémas d'assemblage. - Contrôler que chaque pièce soit bien conforme avant de la coller à sa place.
- N'utilisez pas trop de colle pour relier les pièces. - Ne laissez manipuler la colle ou peinture à proximité d'une flamme.
- Admirez soigneusement la pièce ou vous peignez(ouvrez la fenêtre).
- Après avoir sorti les pièces du sac en caoutchouc, déchirez le sac afin d'éviter que les enfants ne le mettent sur la tête et ne s'étouffent.

<組み立てる前に>

- 組み立てる前に説明書をお読み下さい。 - 部品をランナーから取り出す時は慣用ニッパーとカッターを使用します。
- 接着剤を少しなめに使うことがきれいに仕上げるコツです。 - 塗装する前に部品を合わせて確かめます。
- 接着剤や塗料を使用する時はときどき窓を開けて換気をお願いします。
- 組み立て後の部品やビニール袋は小さな子供の手の届かない安全な所に保管して下さい。

1/48th Scale P-26A PEASHOOTER

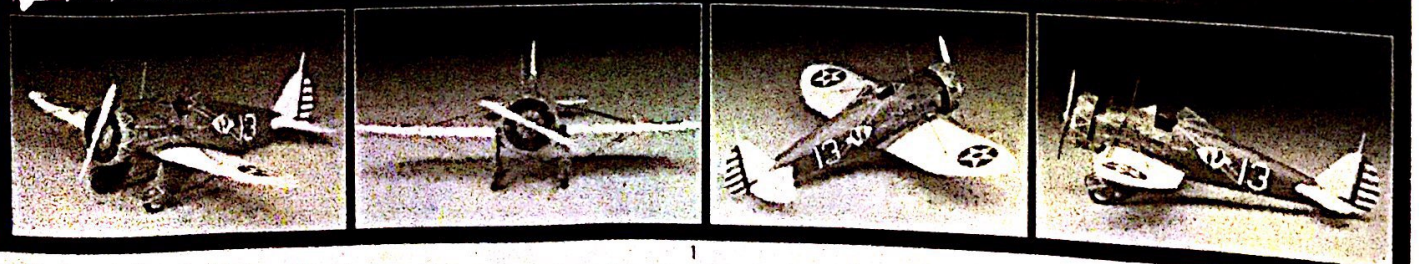

1

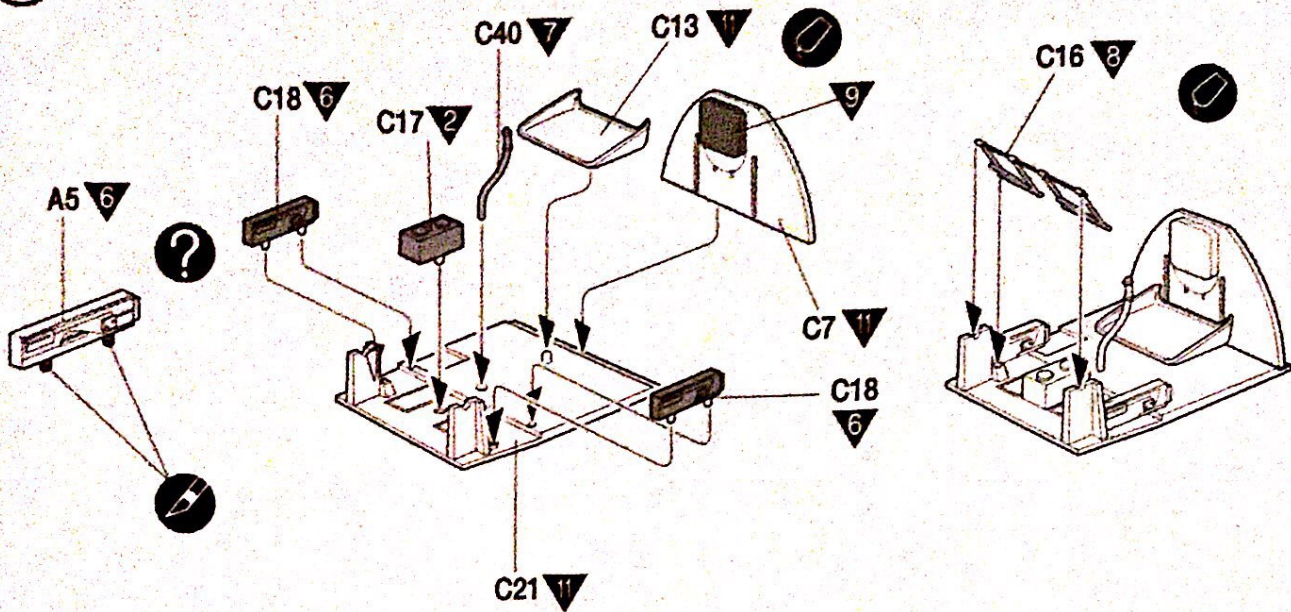

2

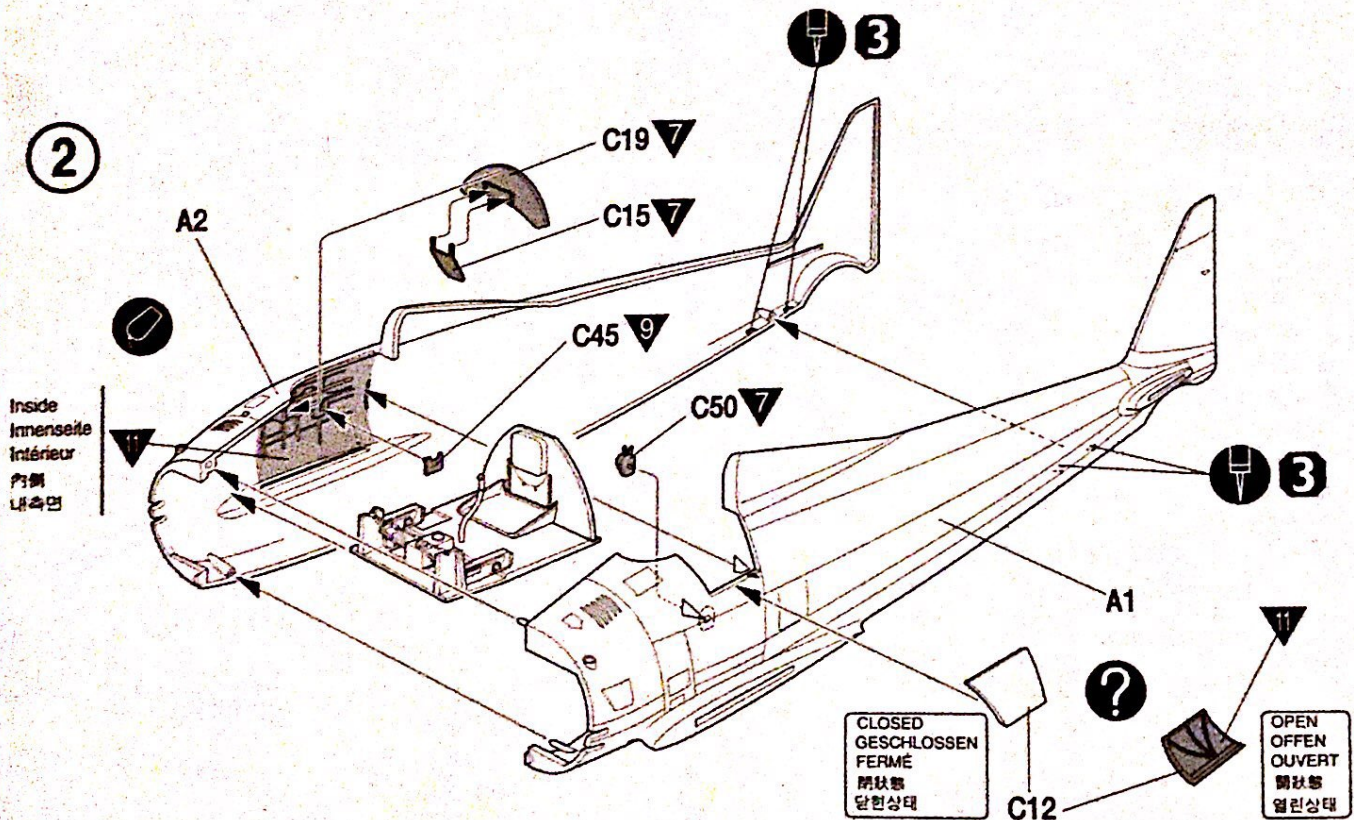

SWITCH
Control Panel
Cover
Mounting
Plate
Mounting
Cover
Mounting



SWITCH
SWITCH
SWITCH
SWITCH
SWITCH
SWITCH
SWITCH
SWITCH



SWITCH
SWITCH
SWITCH
SWITCH
SWITCH
SWITCH
SWITCH
SWITCH



SWITCH
SWITCH
SWITCH
SWITCH
SWITCH
SWITCH
SWITCH
SWITCH



SWITCH
SWITCH
SWITCH
SWITCH
SWITCH
SWITCH
SWITCH
SWITCH



SWITCH
SWITCH
SWITCH
SWITCH
SWITCH
SWITCH
SWITCH
SWITCH



SWITCH
SWITCH
SWITCH
SWITCH
SWITCH
SWITCH
SWITCH
SWITCH



SWITCH
SWITCH
SWITCH
SWITCH
SWITCH
SWITCH
SWITCH
SWITCH



SWITCH
SWITCH
SWITCH
SWITCH
SWITCH
SWITCH
SWITCH
SWITCH



SWITCH
SWITCH
SWITCH
SWITCH
SWITCH
SWITCH
SWITCH
SWITCH



SWITCH
SWITCH
SWITCH
SWITCH
SWITCH
SWITCH
SWITCH
SWITCH



SWITCH
SWITCH
SWITCH
SWITCH
SWITCH
SWITCH
SWITCH
SWITCH

3

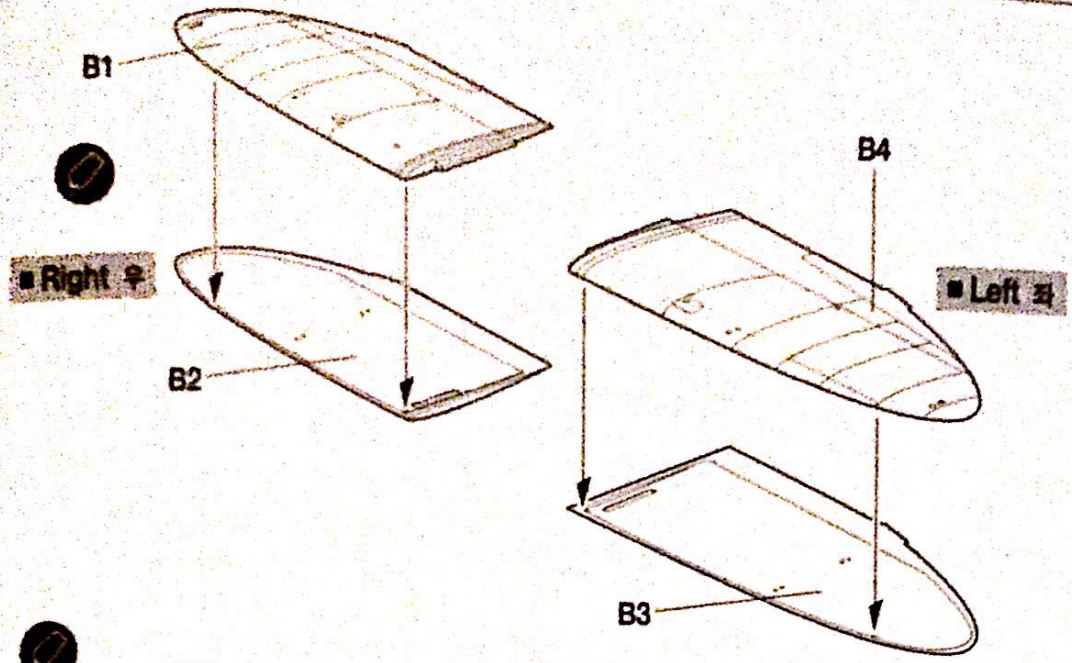

4

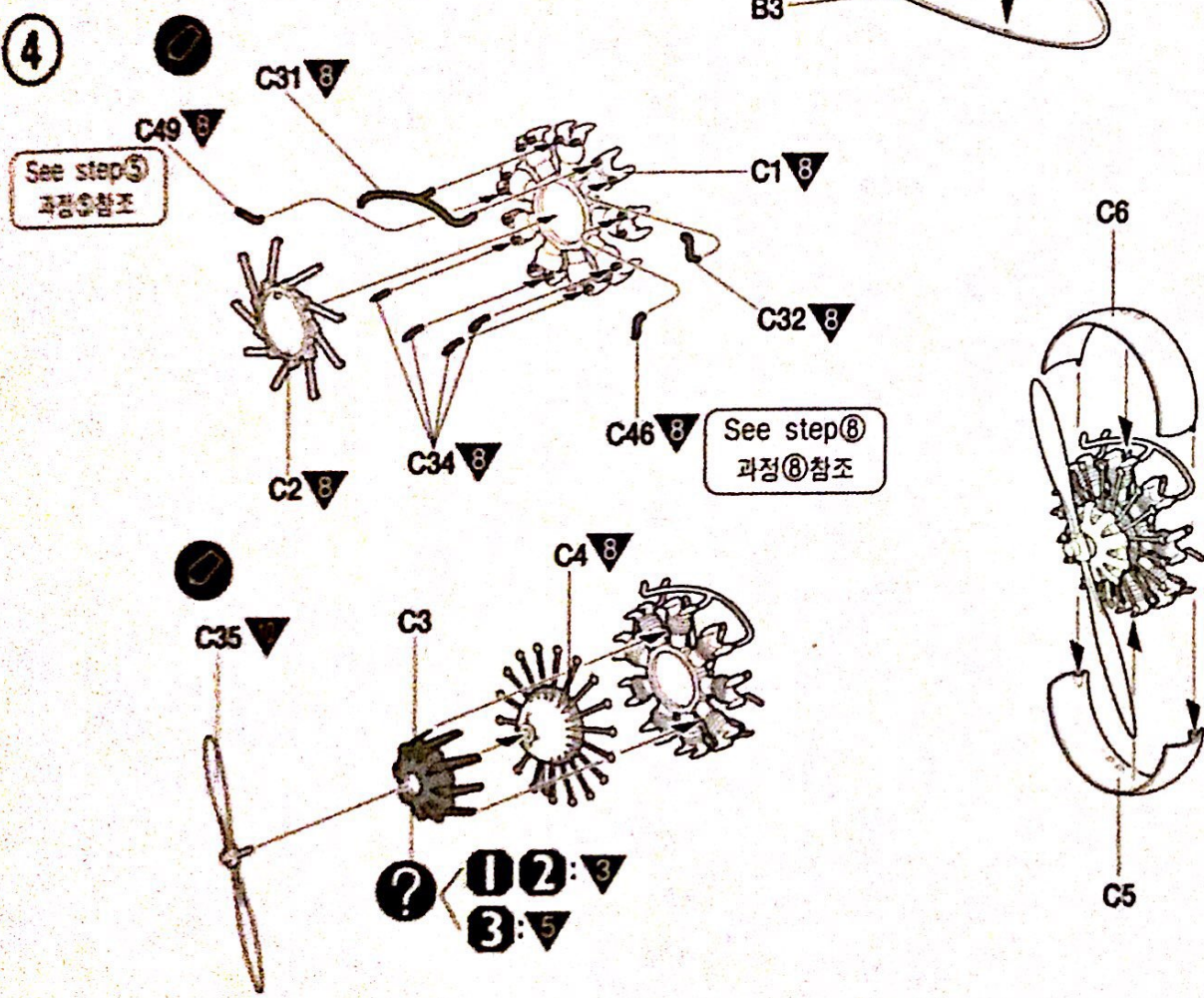

EXHAUST PIPE ASSEMBLY/배기관 조립

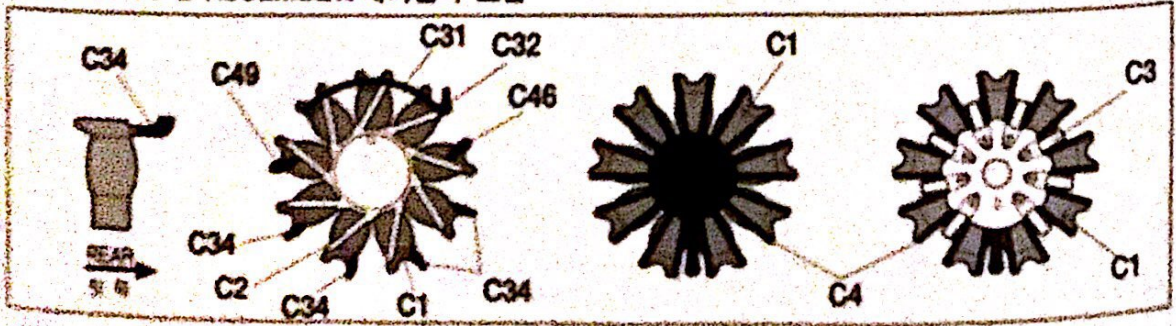

5

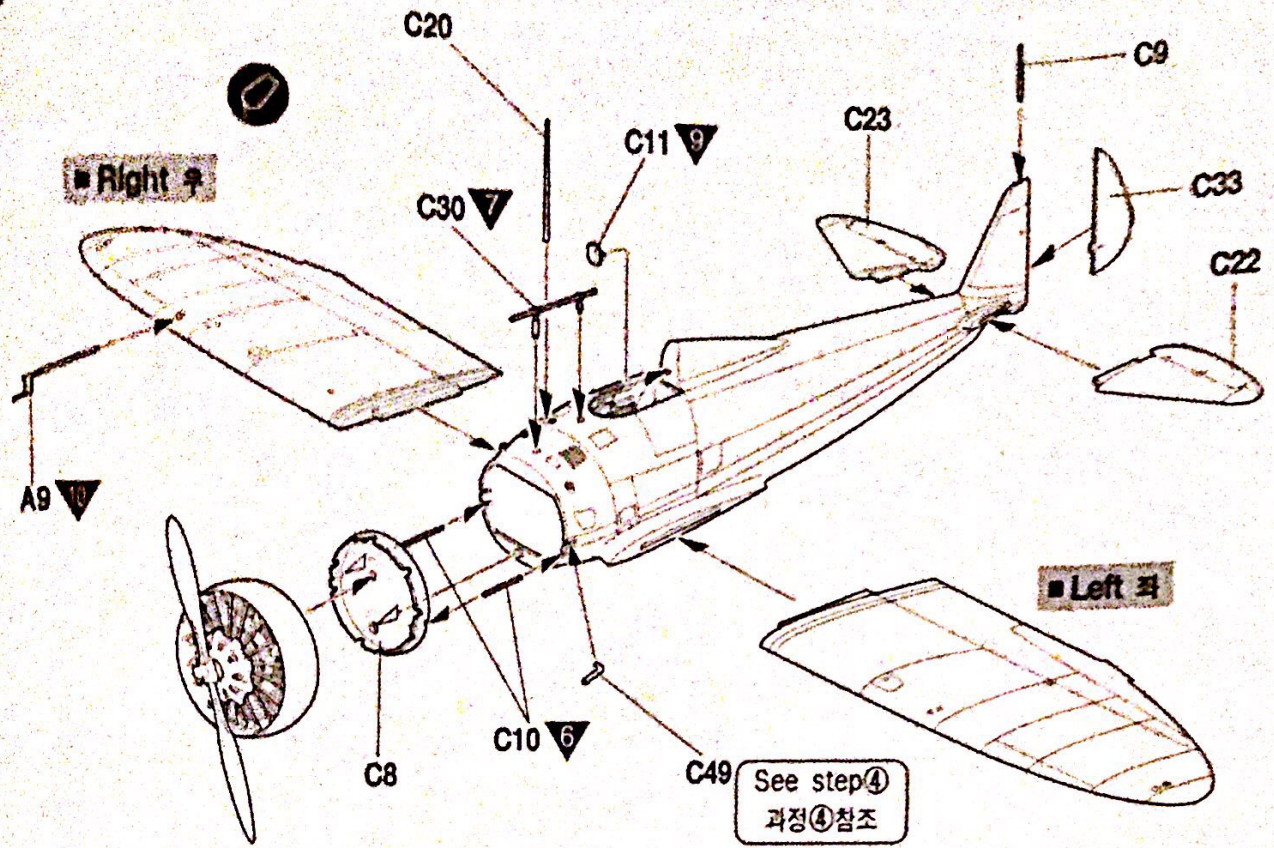

6

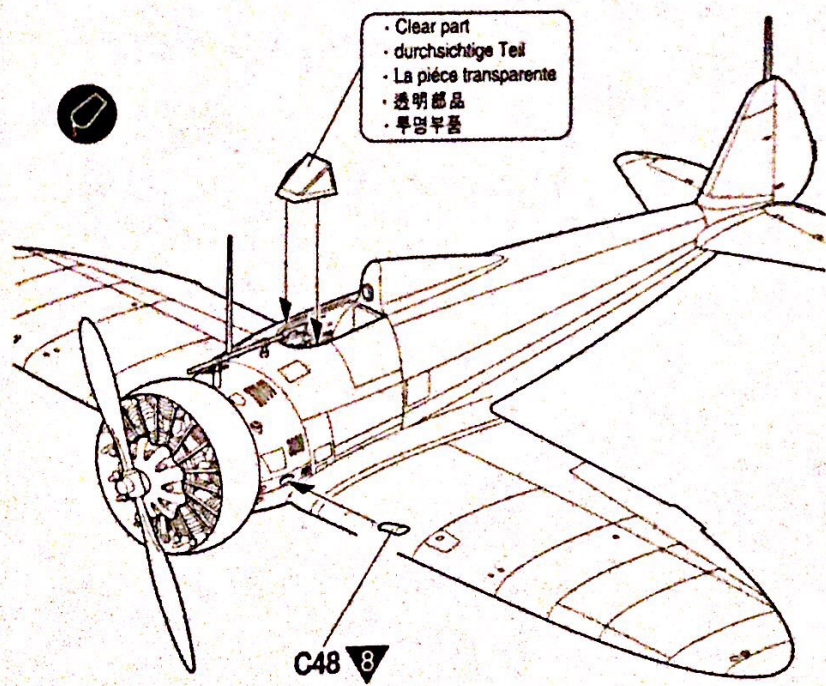

▼ WHITE	WEISS	BLANC	ホワイト	유광흰색
▼ BLACK	SCHWARZ	NOIR	블랙	유광 검정색
▼ RED	ROT	ROUGE	레드	유광 빨강색
▼ YELLOW	GELB	JAUNE	イエロー	유광 노랑색
▼ MEDIUM BLUE	MITTELBLAU	BLEU MOYEN	미디엄블루	미디엄블루
▼ GUNMETAL	METALLGRAU	GRIS ACIER	گان 메탈	건메탈



7

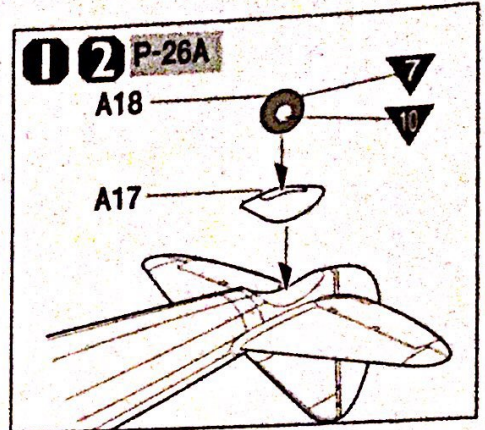
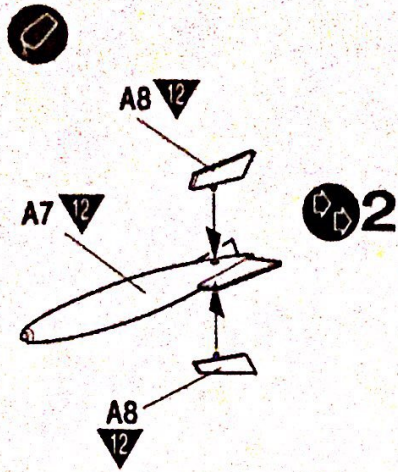

8

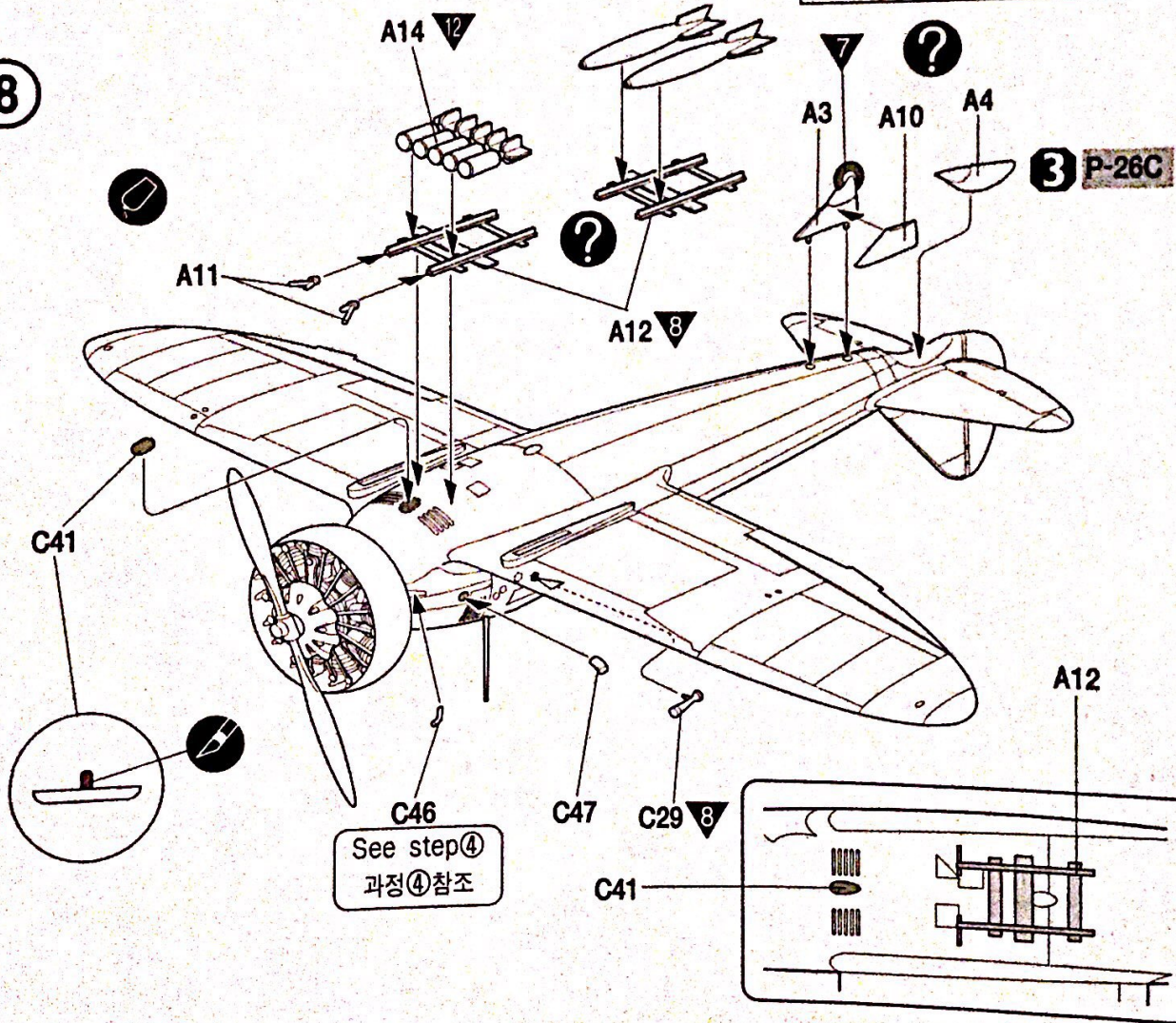

▽	FLAT BLACK	MATTSCHWARZ	NOIR MAT	つや消しブラック	무광 검정색
8	METALLIC GRAY	GRAUMETALLIC	GRIS MÉTAL	메탈릭그레이	흑철색
9	RED BROWN	ROTBRAUN	BRUN ROUGE	레드브라운	레드 브라운
▽	SILVER	SILBER	ARGENT	실버	은색
▽	INTERIOR GREEN FS34151	INNEN GRÜN	VERT INTERIEUR	인테리어그린	인테리어그린
▽	OLIVE DRAB FS34067	BRAUNOLIV	VERT OLIVE	올리브드라브	국방색

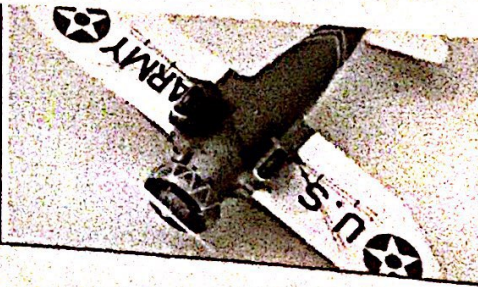

9

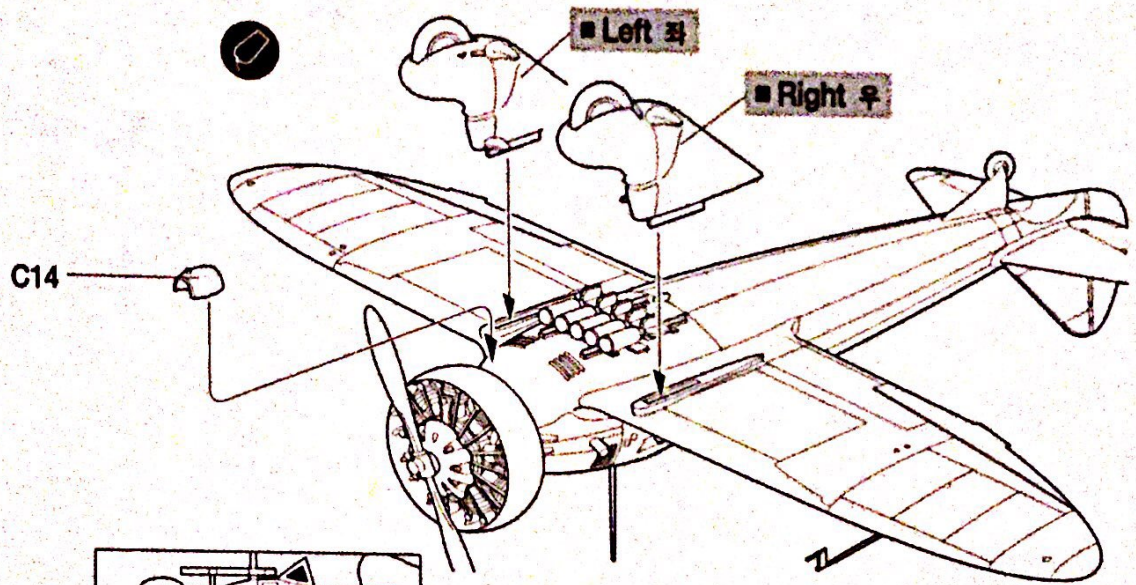
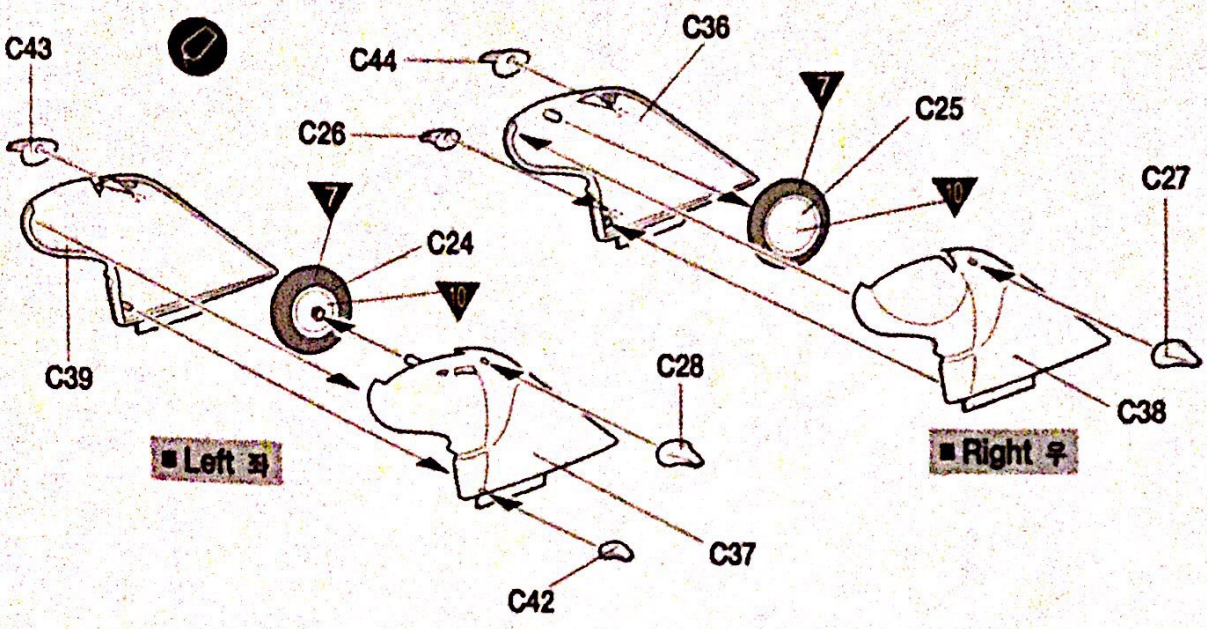

10

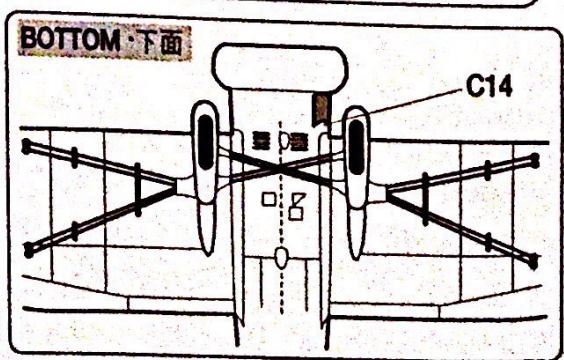
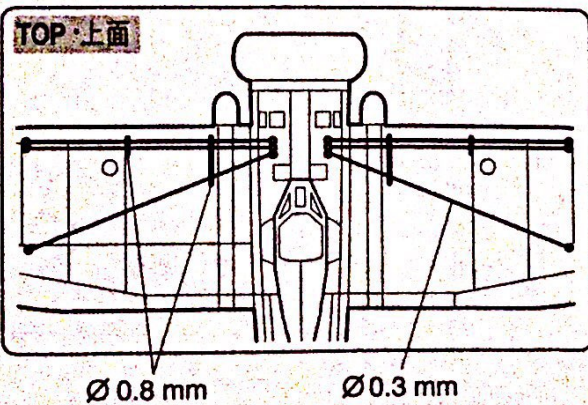
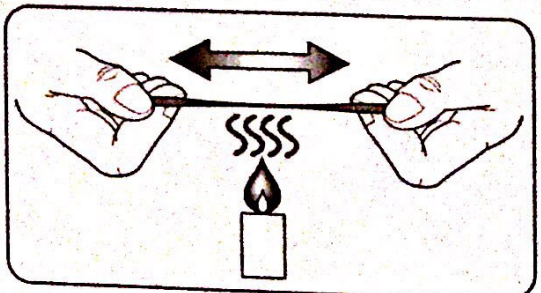
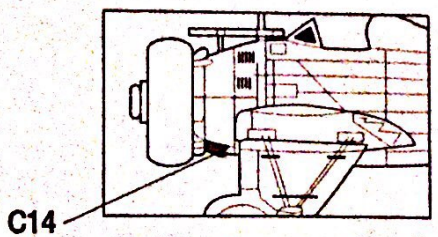

Parts Locating Diagram 부품도

A

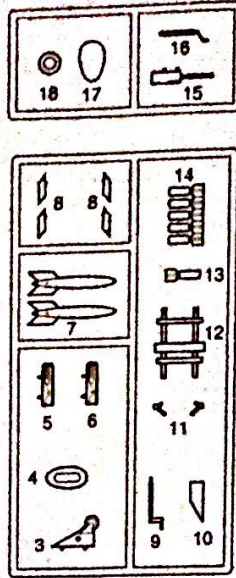
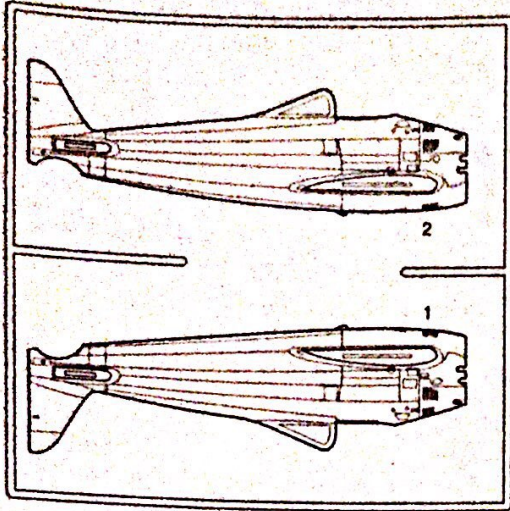

B

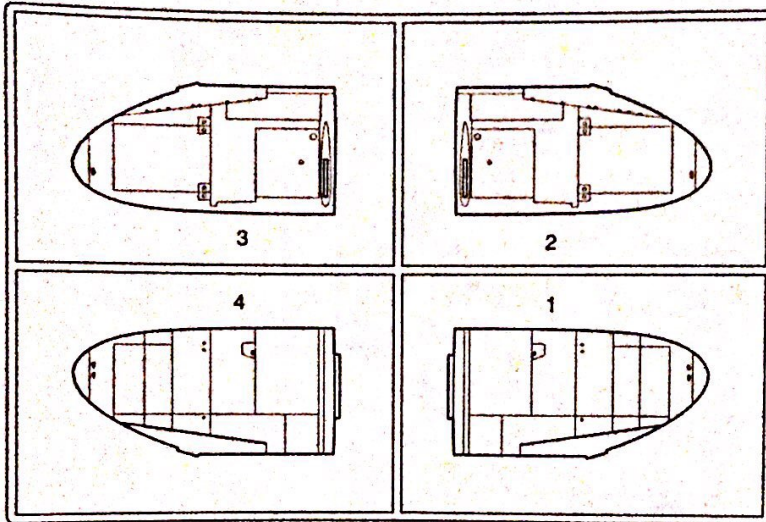

Unused parts
Nicht verwenden
Pièces non utilisées : A6, A13, A15, A16
不要部品
불필요 부품

C

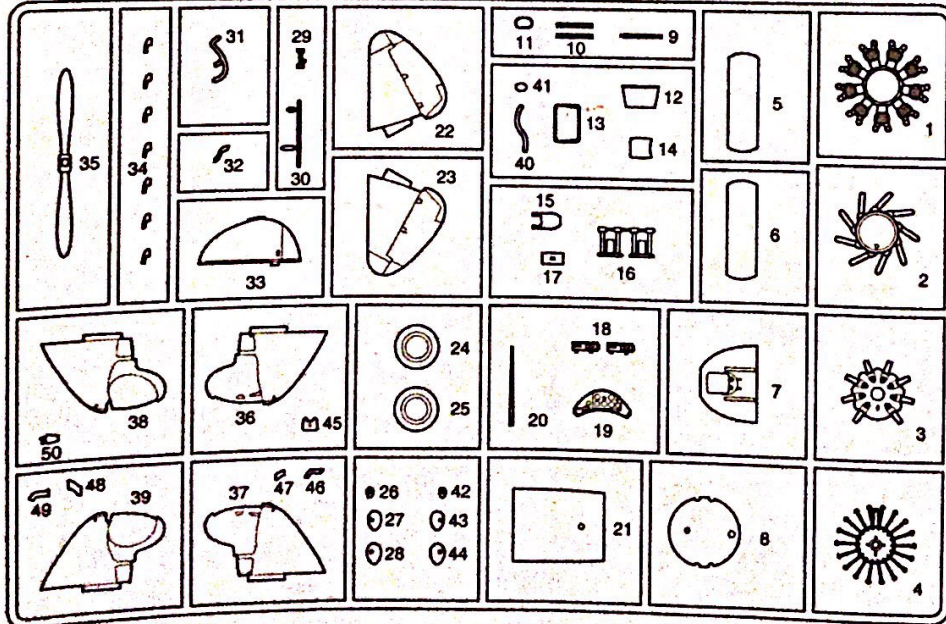

• Clear part
• durchsichtige Teil
• La pièce transparente
• 透明部品
• 투명부품

● 판매점 A/S센터: 대전동 552-9293, 삼선교 742-9293, 양재동 575-9997, 용산 796-1214, 아셈하비센터 6002-6293
 ● A/S센터: 본사 908-7000(교합147), 동대문 745-9293, 천호동 473-9293
 ● 출판점 겸 A/S센터: 강남아카데미 495-6884, 김복아카데미 762-0980, 경기아카데미 (0343)458-5591, 노원아카데미 907-0940
 ● 고객상담문의: 대구아카데미 (053)744-9293, 양천아카데미 691-7108, 부산아카데미 (051)293-7448
 ● 홈페이지: 080-969-7000 E-Mail: academy@academy.co.kr
 http://www.academyhobby.com http://www.academy.co.kr



ACADEMY PLASTIC MODEL CO., LTD.
273-64, Suyu-dong, Kangbuk-gu, Seoul, Korea
TEL 82-2-908-7000 FAX 82-2-997-3003

Copyright 1998 Academy Plastic Model Co., Ltd.

Made in Korea

Painting & Decal placement 색칠 및 전사지 붙이기

USAAF P-26A, 94th Pursuit Squadron, Selfridge Field, Michigan, 1935-36
 미육군 항공대 제94추격비행대 소속 P-26A, 미시건주 셀프릿지 비행장, 1935-36년

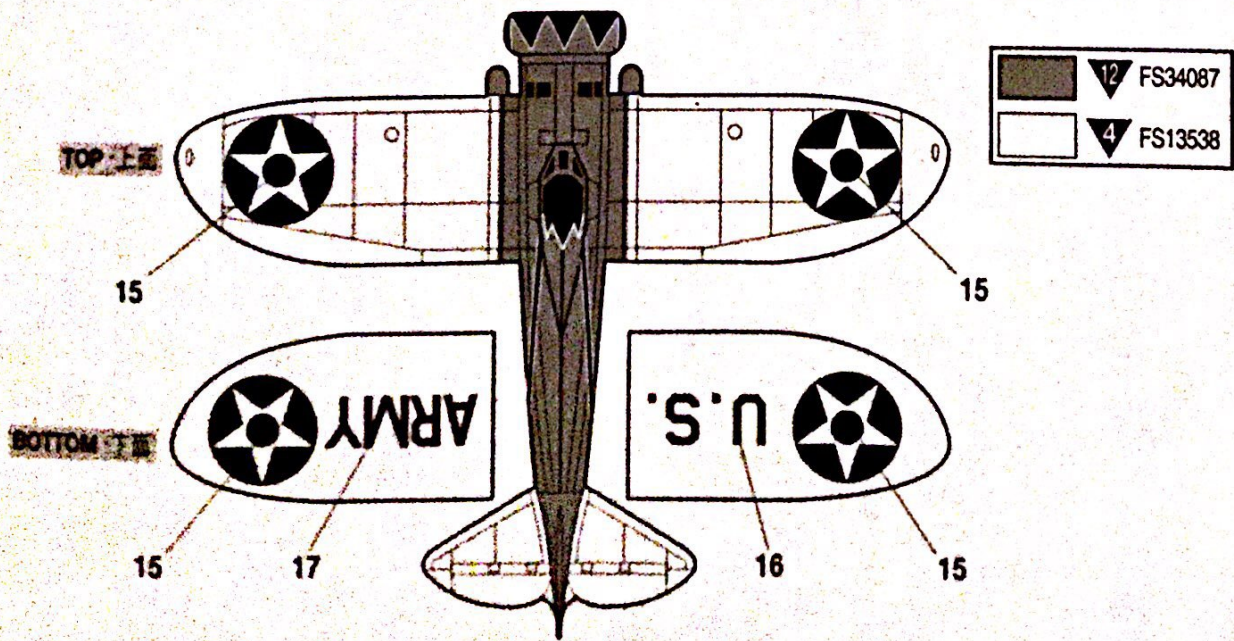
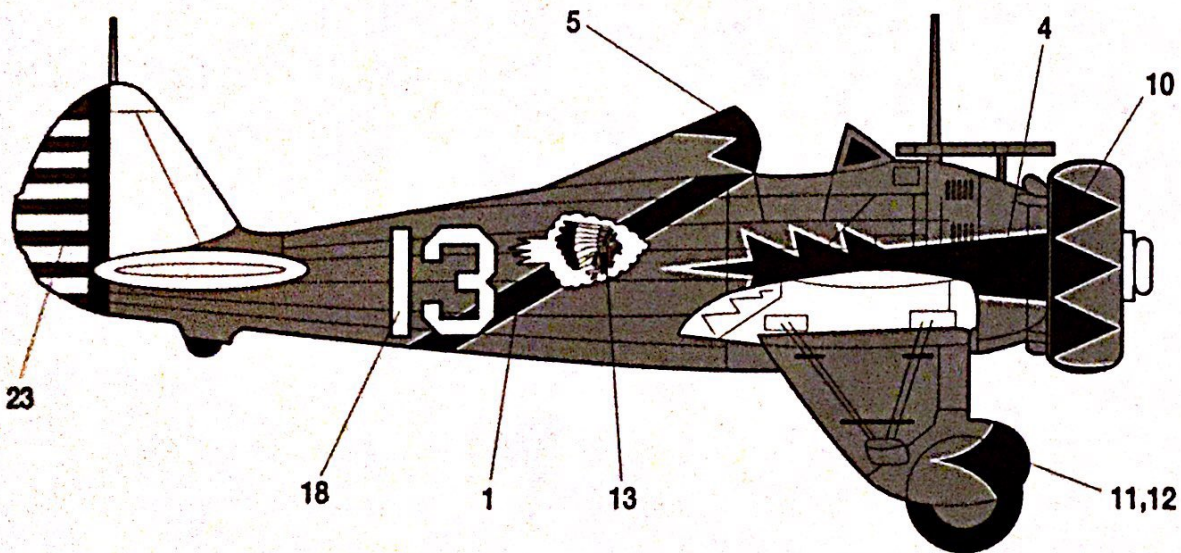
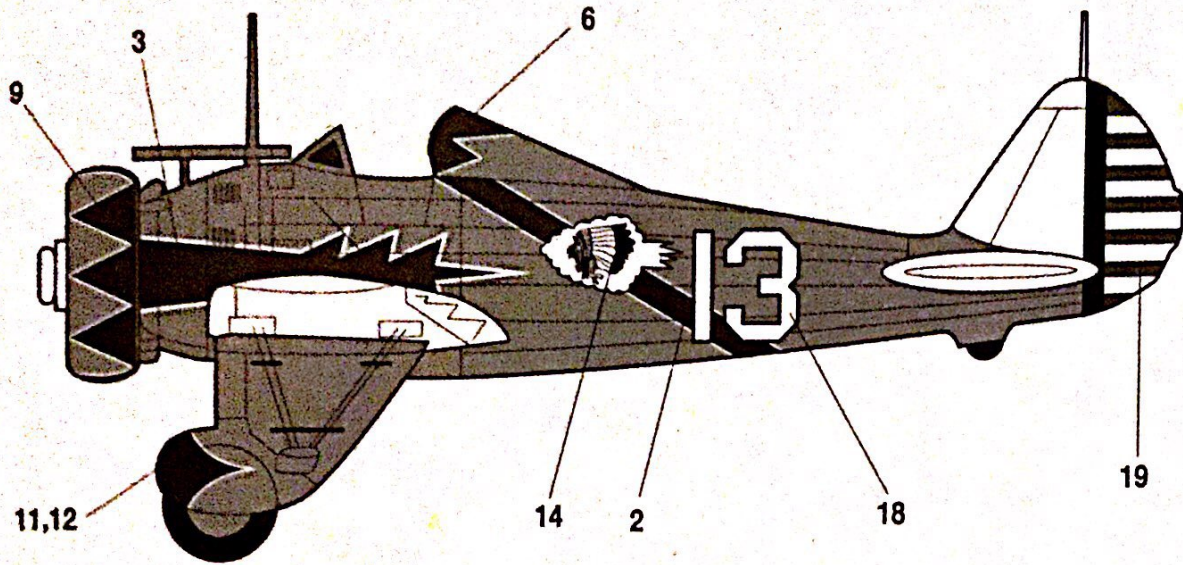

Painting & Decal placement 색칠 및 전사지 붙이기

3 USAAF P-26C, 94th Pursuit Squadron, 1935-36
 미육군 항공대 제94추격비행대 소속 P-26C, 1935-36년

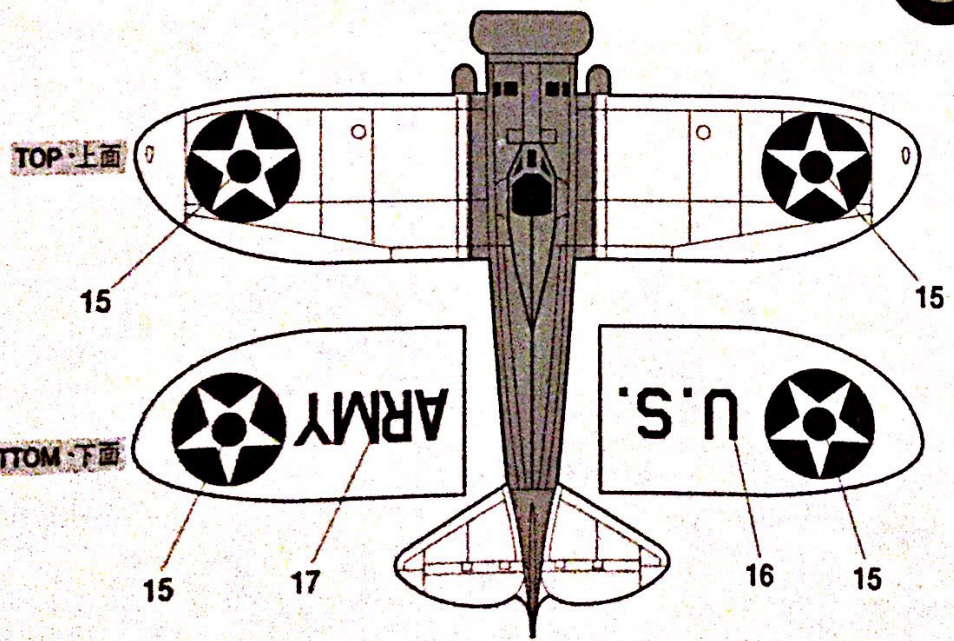
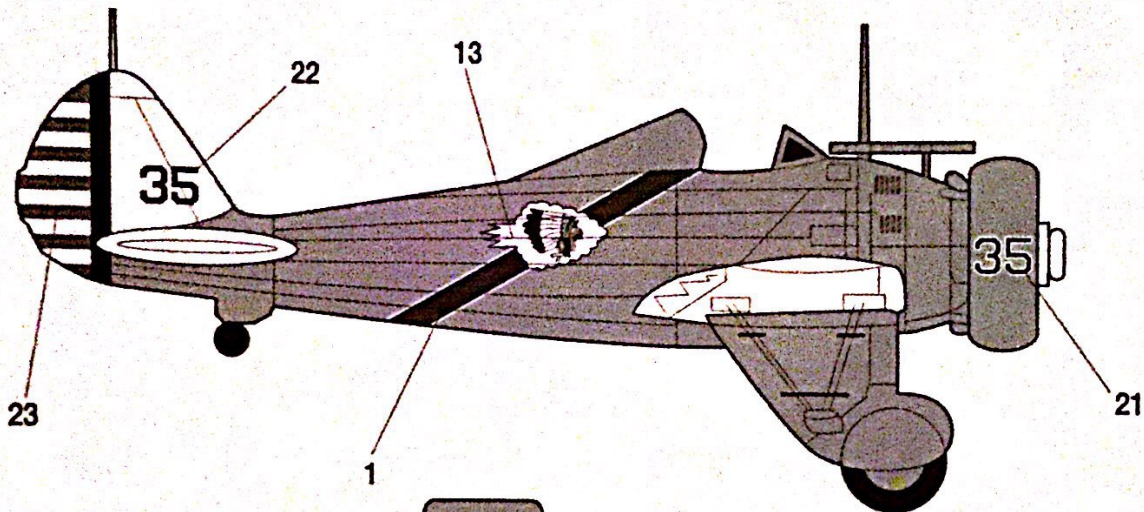
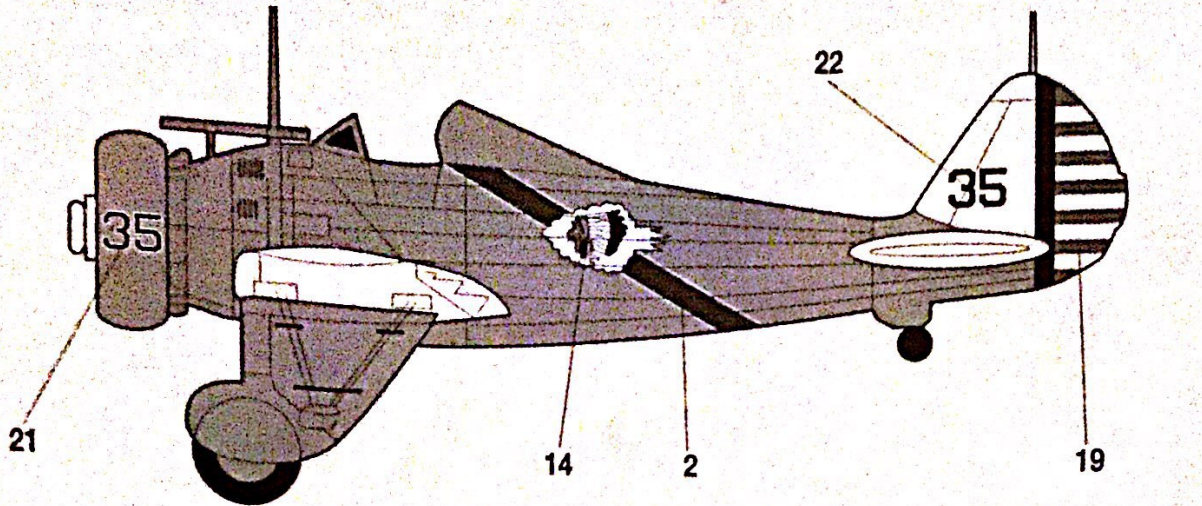

	12	FS35109
	4	FS13538

* 판매점 및 A/S센터
 * A/S센터
 * 출판점 및 A/S 센터
 * 고객상담문의 : 홈페이지
 * 홈페이지
 남산로 749-8283, 대전동 502 8293, 양재동 576-9987, 용산 796-1214
 본사: 908-7000 (고정 147), 통영본: 745-8293, 천안동: 473-8293
 노원아카데미: 907-0940, 양천아카데미: 691-7198, 강북아카데미: 762-0989
 강남아카데미: 522-1577, 송파아카데미: 103431458-5591,
 부산아카데미: 1051293 7448, 대구아카데미: 10531744-8293
 080-969-7000
<http://www.academy.co.kr>
<http://www.academyhobby.com>

ACADEMY ACADEMY PLASTIC MODEL CO., LTD.
 273-64 Suni-dong Kangbuk-gu Seoul Korea
 TEL: 82-2-906-7000 FAX: 82-2-907-9933

Painting & Decal placement 색칠 및 전사지 붙이기

2 USAAF P-26A, 19th Pursuit Squadron, Wheeler Field, Hawaii, 1940
미육군 항공대 제19추격비행대 소속 P-26A, 하와이주 휠러 비행장, 1940년

