

Combat Models

malliharrastajan tavaratalo



SISU A-45 "Proto"

Instruction for 1/72 scale Sisu A-45 "Proto" model kit.

To build this kit, you need a hobby knife, small side cutters, sandpaper or file and plastic glue. We recommend to use Tamiya "green cap" glue.

A-45 was informally called *Proto*. The name is derived from the Finnish word "prototyypä" (prototype). This truck was made by Sisu 1970-1982. This vehicle was used on peacekeeping operations, by The Finnish Defence Forces and VR (Finnish State Railways) as recovery vehicle. A45 was also used as fire engine/truck.

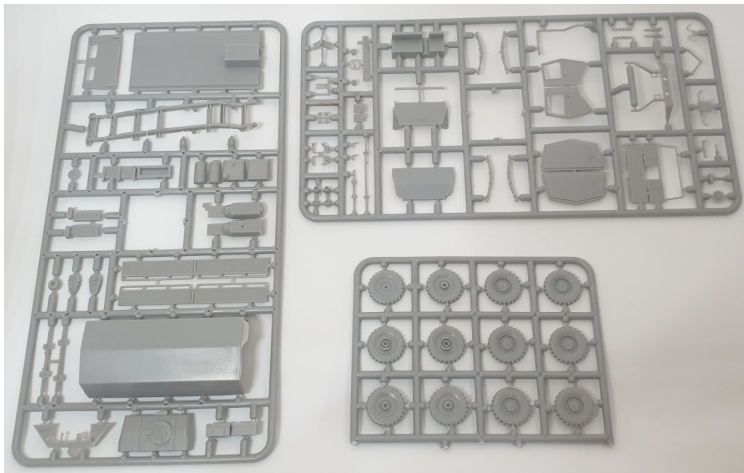

Start this model from engine. Notice, that front of the lower part of engine is under the frame. Parts as exhaust manifold you can use ONLY if you make diorama of engine service. When you use truck platform, because on material thickness there is not enough place for exhaust manifold parts, ie leave parts marked with red out.

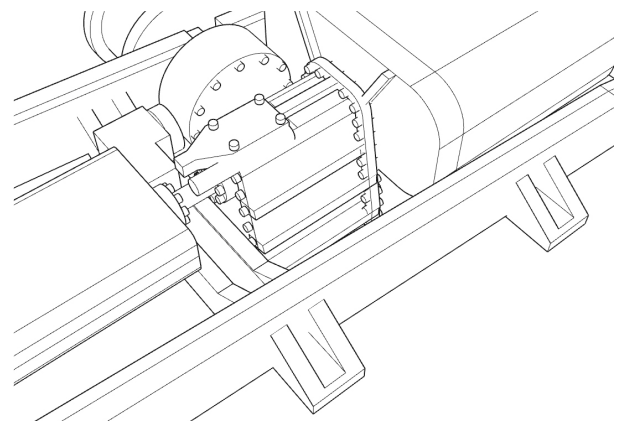
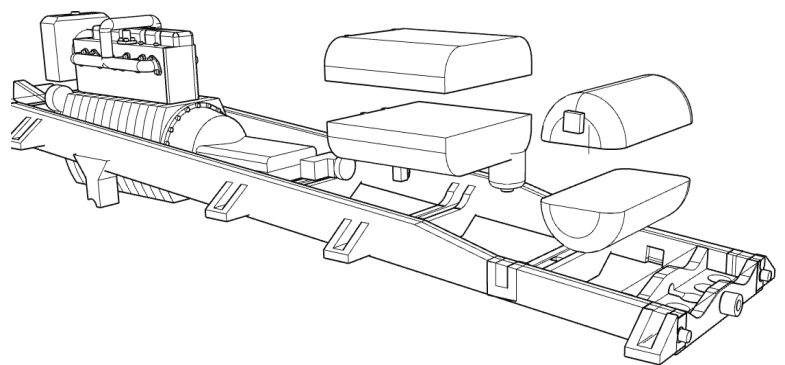
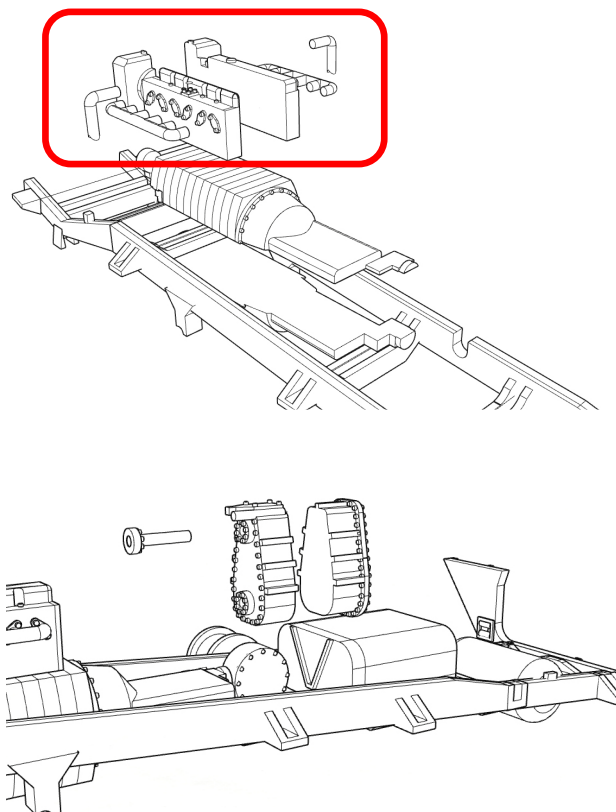

Next you can add end, hook, winch, boxes and spare tire.

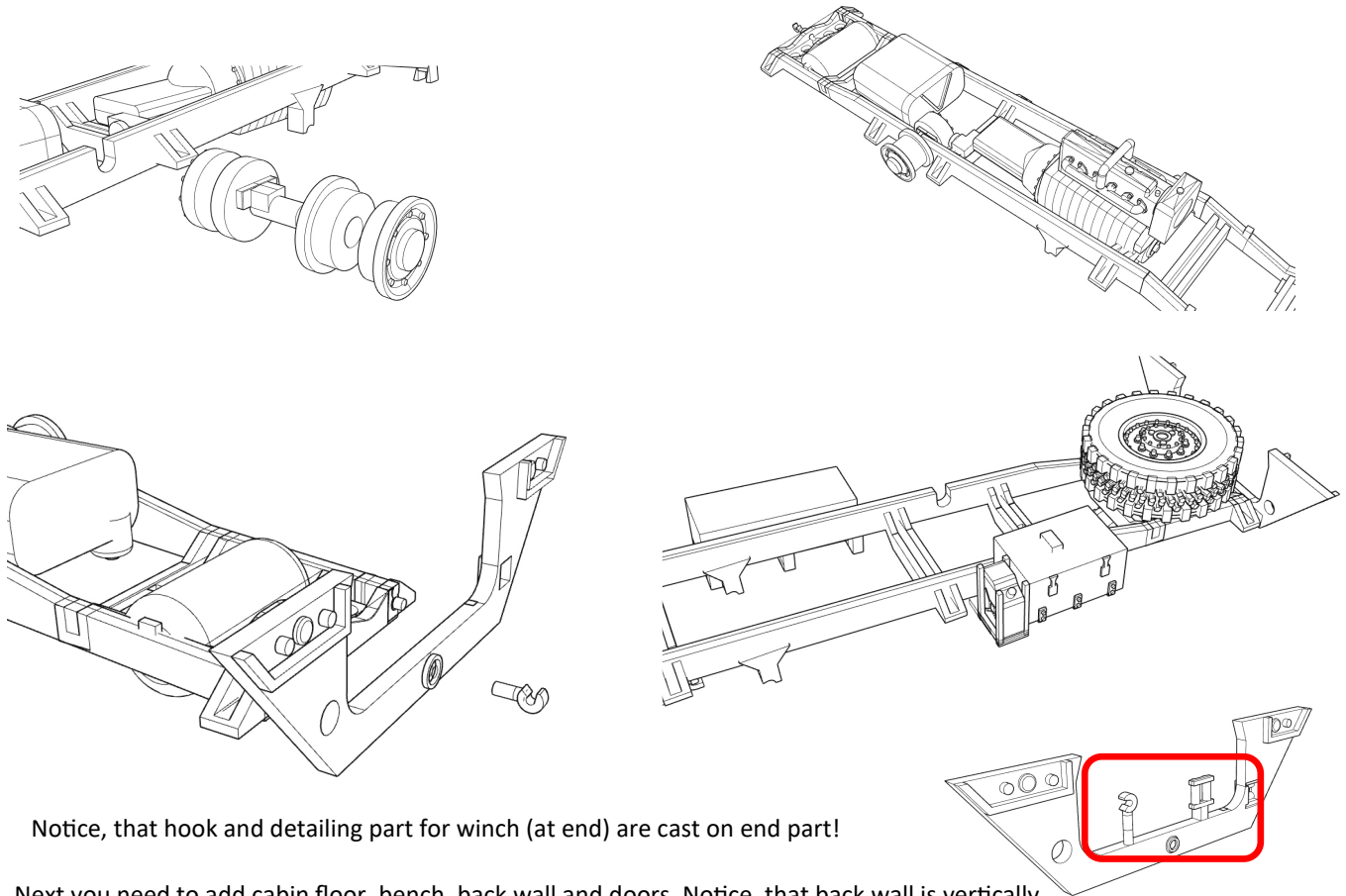

Next you need to add cabin floor, bench, back wall and doors. Notice, that back wall is vertically

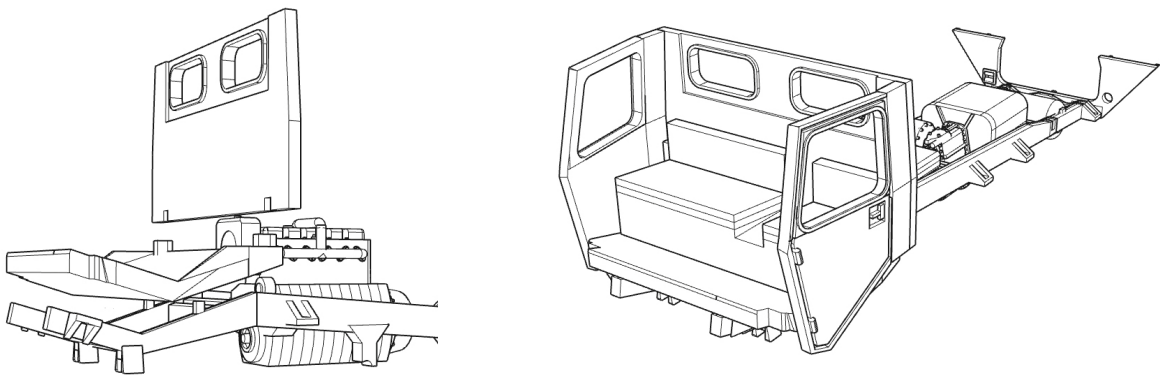

Add front of the A-45, dashboard and steering wheel. Also after you add windows, you can glue the roof and bumper

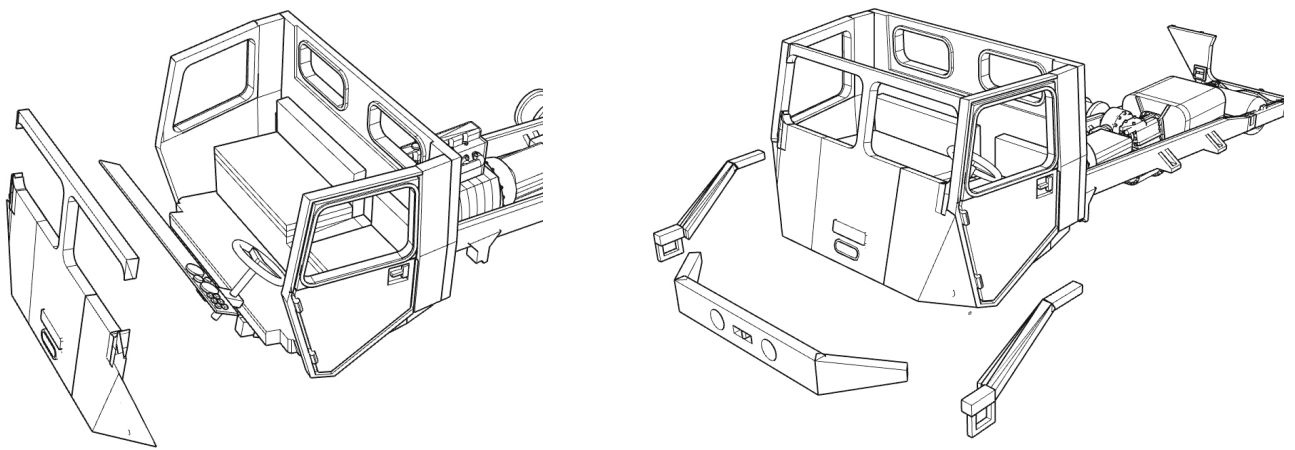

After cab is finished glue the springs under the chassis.

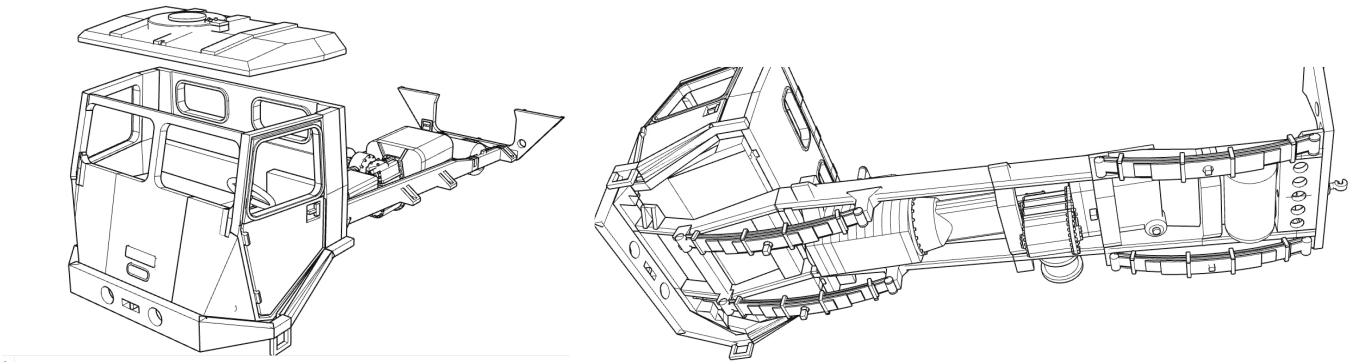

Now you need to build axles. Glue parts together and then cut axles and glue together like on picture. While doing it, measure it with springs. Shorter one is front axle

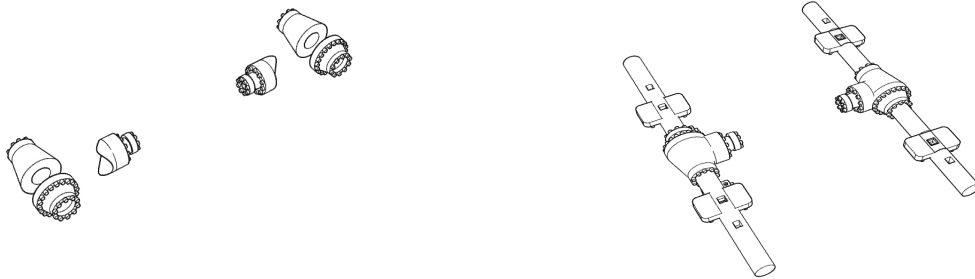

Now you can glue shock absorbers to front and all four brakes

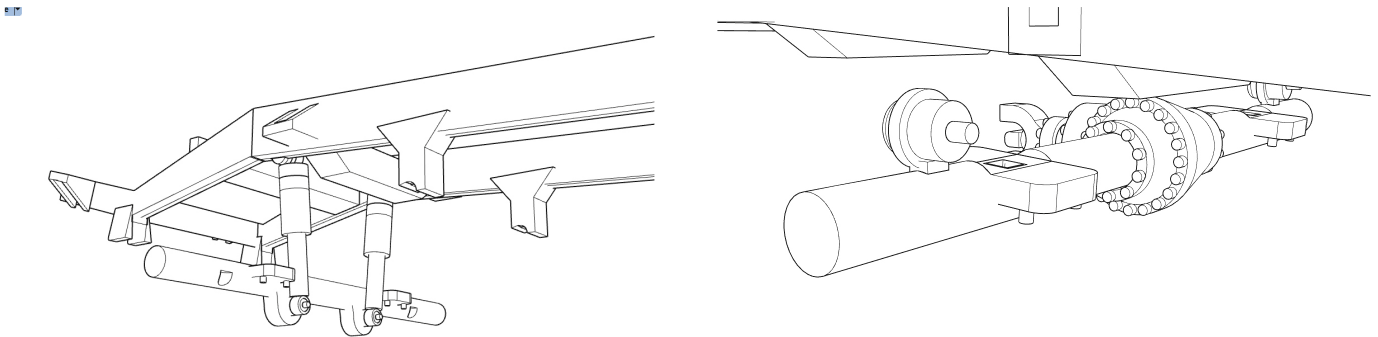

Now you can glue cardan shafts

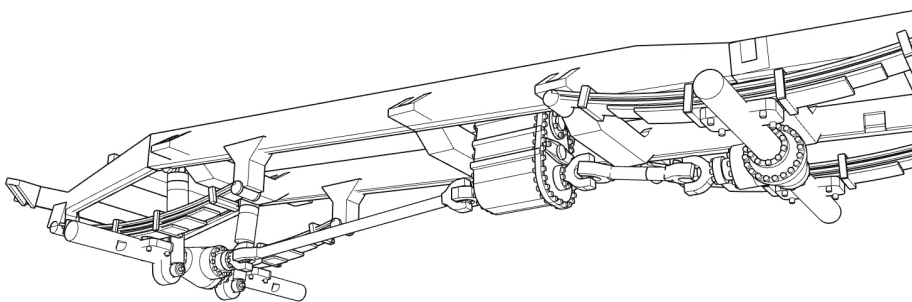

Next is truck platform, platform support parts, bumper details, front axle protection and exhaust pipe.

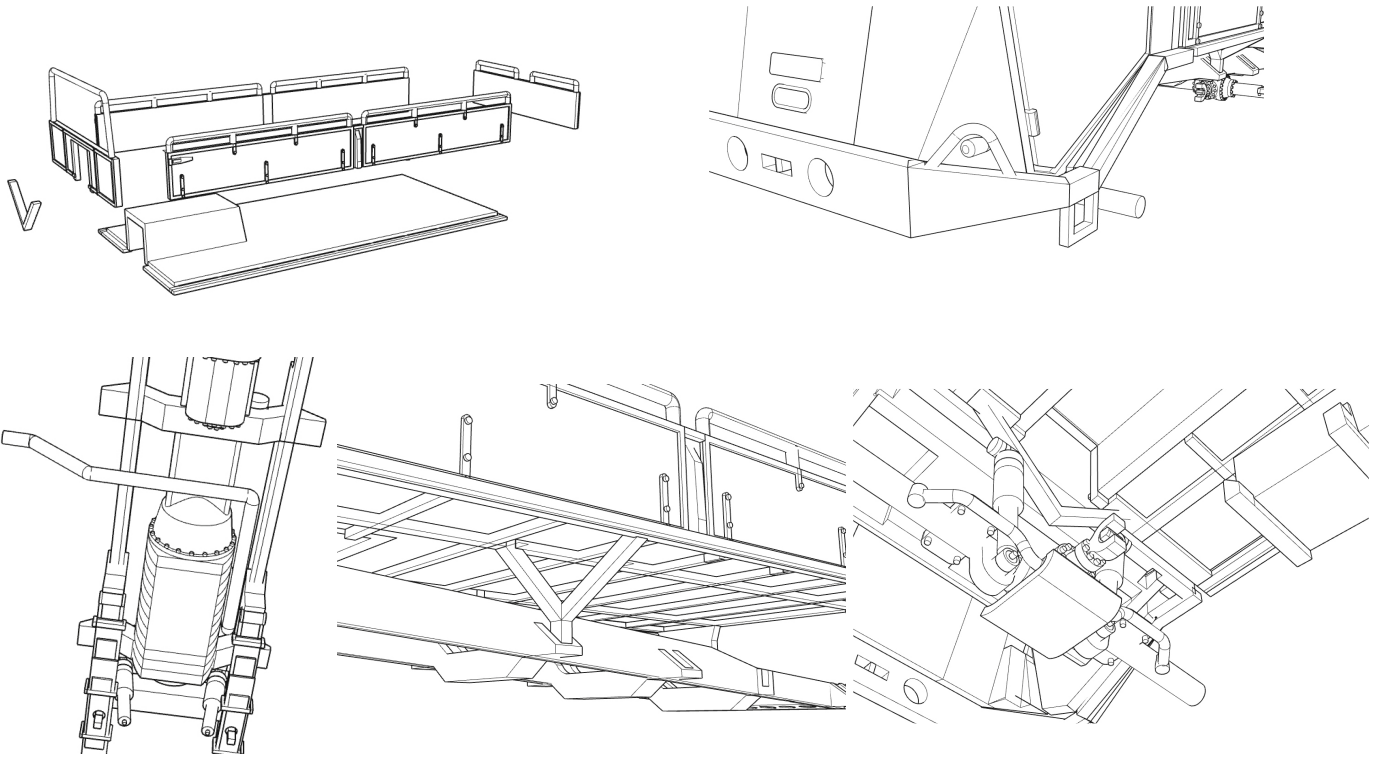

Spare wheel

Front wheel

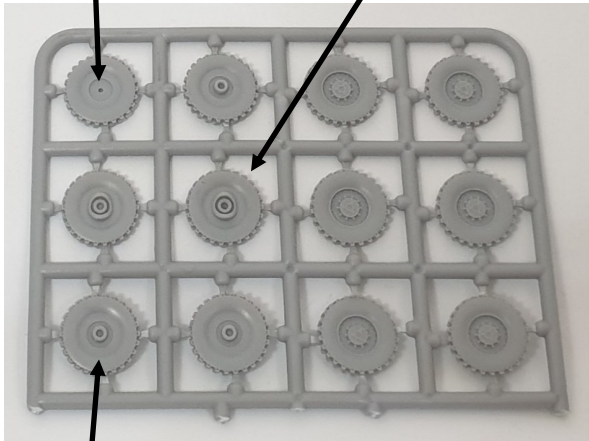

Rear wheel

And now wheels and mirrors and your model is ready for painting
Wheels are assembled from two parts, note difference of inner parts!

See separate painting and marking instruction!

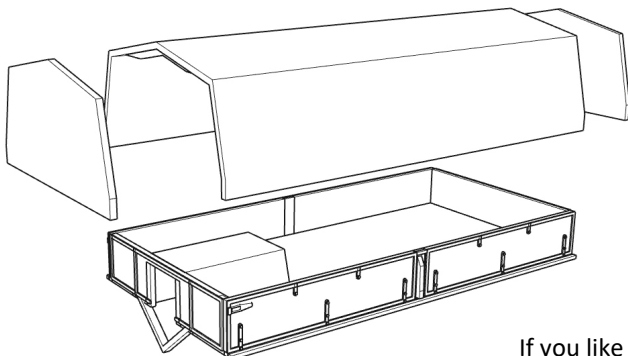
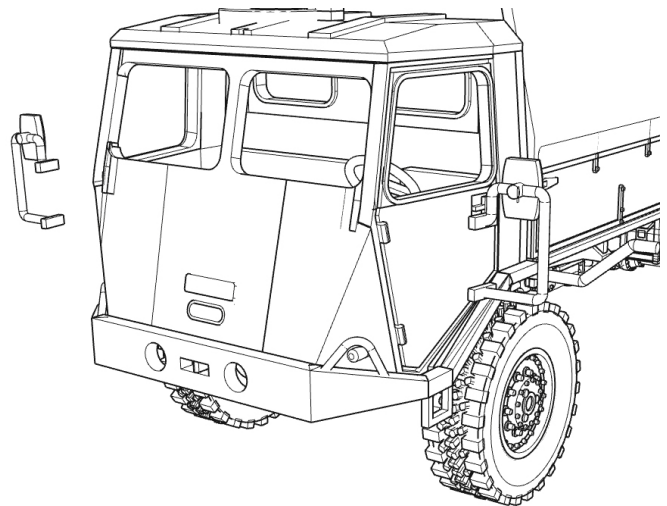

If you like to build a model with tarpaulin, you need to cut off handrails