

AZmodel
Plastic kits

Famous German Fighter

Focke Wulf

Fw 190D-11

UNASSEMBLED MODEL KIT. CEMENT AND PAINT NOT INCLUDED.

組み立て式プラスチックモデルキットです。1セット分のプラスチックパーツが入っています。接着剤と塗料はこのキットに含まれておりません。別途お買い求め下さい。

1/72

Scale model kit

スケールモデルキット

Illustration/ 図:
Z. Macháček

AZ 7482

Box contains:

- quality plastic parts
- decal sheet for 3 versions
- full colour instructions



Macháček Z.

- 1** Fw 190D-11, W.Nr.2200XX, Red 4, "Sachsenberg Schwarm", flown by Lt. Karl-Heinz Hofmann, JV44, München-Riem, May 1945.

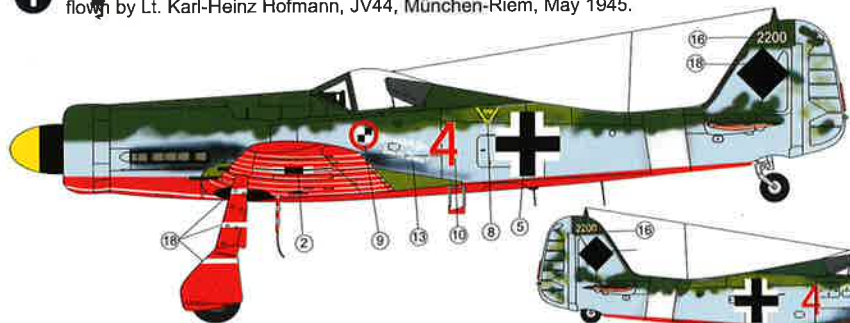

AZmodel
Plastic kits

Colours & Markings

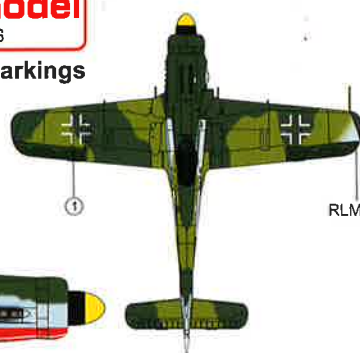

RLM 76

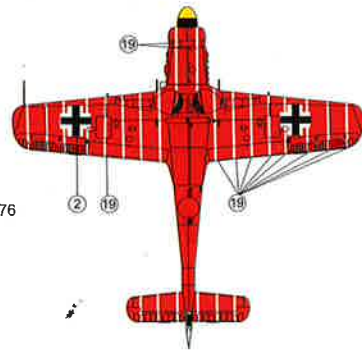

- 2** Fw 190D-11, W.Nr.2200XX, White <-, Verbandsführerschule des G.d.J., Bad Wörishofen, May 1945.

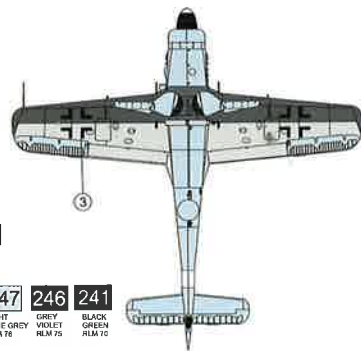
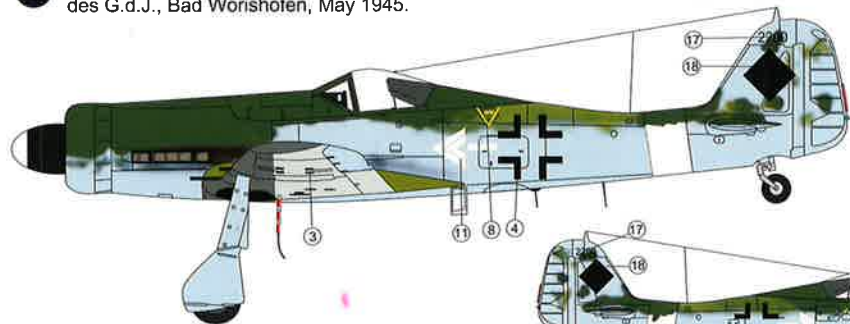

Paint Numbers:
HUMBROL

253	252	247	246	241
LIGHT GREEN RLM 83	DARK GREEN RLM 82	LIGHT BLUE-GREY RLM 78	GREY-VIOLET RLM 75	BLACK-GREEN RLM 70

- 3** Fw 190D-11, W.Nr.220014, White <61, Verbandsführerschule des G.d.J., Bad Wörishofen, May 1945.

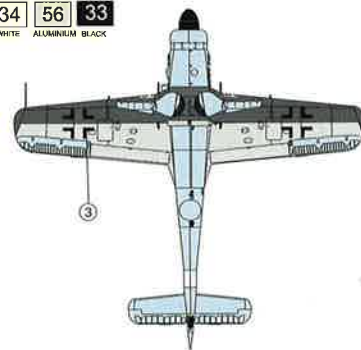
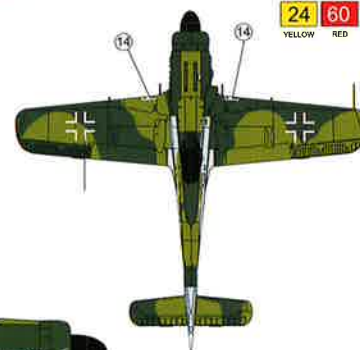
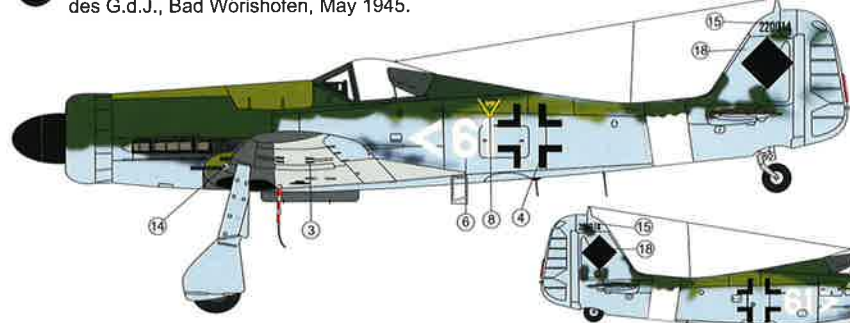

24	60	34	56	33
YELLOW	RED	WHITE	ALUMINIUM	BLACK

Focke - Wulf

Fw 190D-11

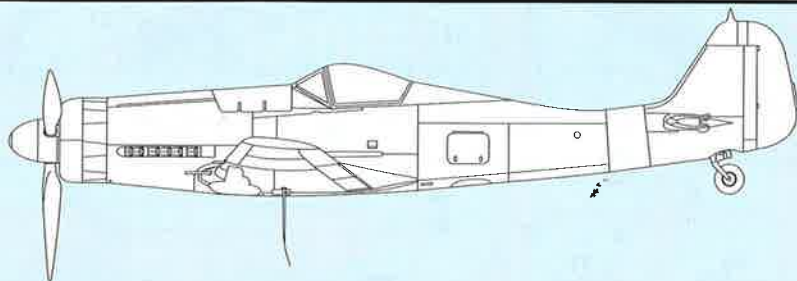

Historie

Stíhací letoun Focke-Wulf Fw 190 D, někdy také nazývaný Langnasen-Dora (dlouhonosá Dora). Jako prototypy pro verzi D bylo využito šest letounů Fw 190 A. Letouny byly vybaveny motorem Jumo 213 A. Prototyp V21 dostal nové konce křídel, jež zvětšily rozpětí o 11 cm. Trup byl prodloužen o 50 cm kvůli vyvážení, protože řadový motor Jumo 213 A byl delší než původní hvězdicový motor BMW 801. Letouny byly vyzbrojeny dvěma kulomety MG 17 v trupu a dvěma kanóny MG 151/20.

Další dva letouny obdržely motory Jumo 213 A-1 o výkonu 1 776 k. Výzbroj tvořily dva kulometry MG 131/13 v trupu a čtyři kanóny MG 151/20 v křídlech.

Fw 190 D-11 byly vyzbrojeny další dvojicí kanónů MK 108/30 umístěných ve vnějších částech křídel, zatímco v trupu na motoru nenesl Fw 190 D-11 žádnou výzbroj. Jako pohon byl použit motor Jumo 213 F nebo F-1.

History in brief

Fighter Focke-Wulf Fw 190 D was known as Langnasen-Dora. As prototypes for the Fw 190D version was used six aircraft Fw 190 A. The aircraft was equipped with the engine Jumo 213 A.

The V21 prototype has got a new wingtips, which increased the wingspan over 11 cm. Fuselage has been extended over 50 cm because inline engine Jumo 213 A was longer than the original BMW 801 radial engine. Aircraft were armed with two MG 17 machine guns in the fuselage and two guns MG 151 / 20 cannons in the wings. Next versions were equipped by 1776 PS Jumo 213 A-1 engines. Armament consisted from two MG 131/13 machine guns in the fuselage and four cannons MG 151/20 in the wings.

The Fw 190 D-11 were equipped with the Jumo 213F engines. Two 30 mm MK 108 cannons were installed in the outer wings and 20 mm MG 151s in the inboard position.

Symbols



Drill hole



Cyanoacrylate



Remove



Reduce



Make new



Option



Bend



Putty

	Colour name	Humbrol		Colour name	Humbrol
A	RLM 22 Black	H33	G	Aluminium	H56
B	RLM 21 White	H34	H	RAL 01 Silver	H11
C	RLM 66 Black Grey	H67	I	RLM 24 Blue	H25
D	Gunmetal	H53	J	RLM 23 Red	H60
E	RLM 70 BlackGreen	H241	K	RLM 02 Grey	H240
F	RLM 04 Yellow	H24	L	RLM 26 Brown	H113

References:

Richard A. Franks
The Focke-Wulf Fw 190D and Ta 152:
A Complete Guide to the Luftwaffe's
Last Piston Engine Fighters
(Airframe & Miniature).

Stefan Draminski
Focke Wulf Fw 190
Internet

Plastic parts

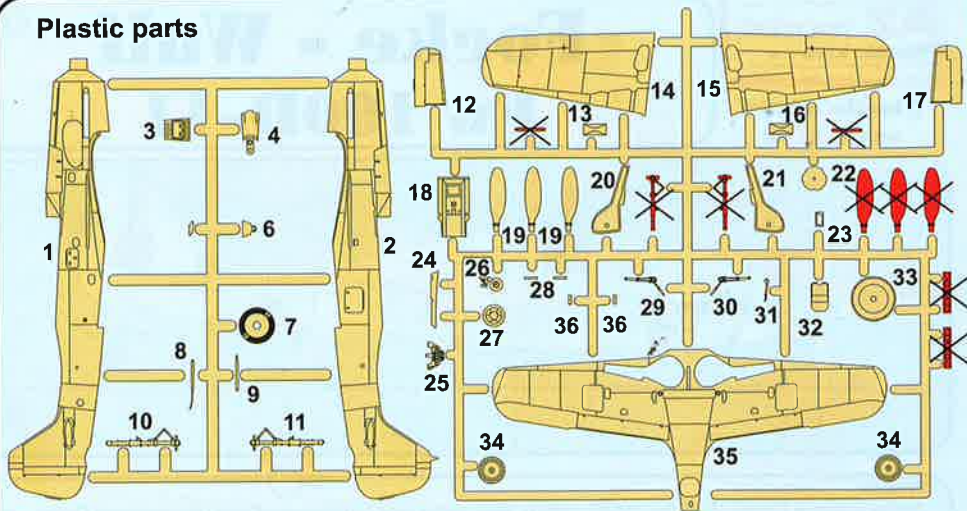

Clear parts

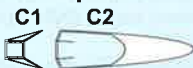

Resin parts

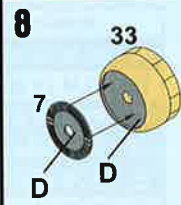
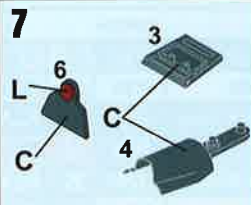
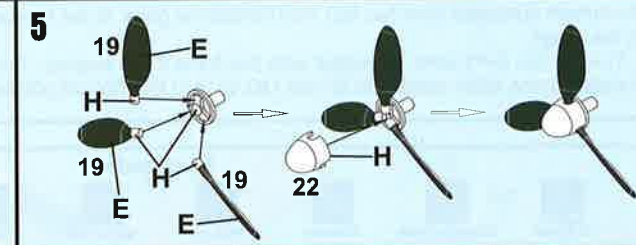
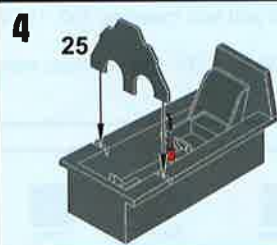
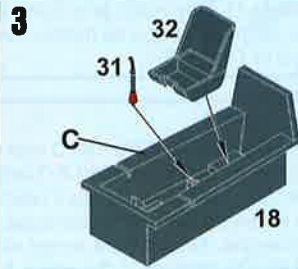
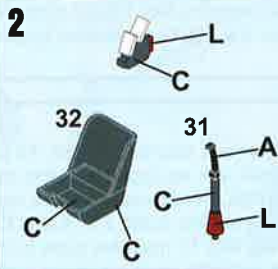
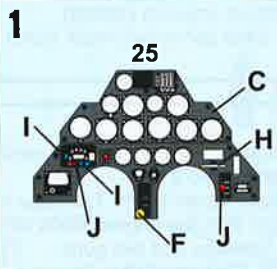

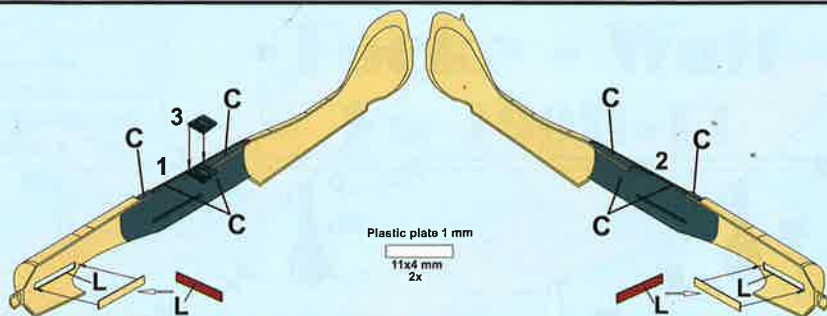
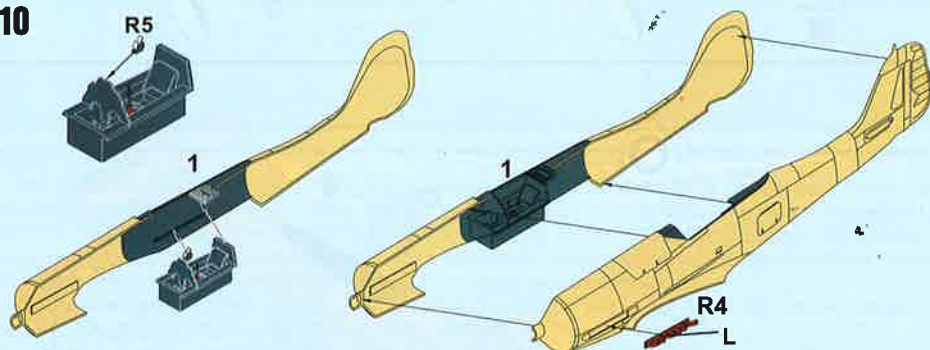
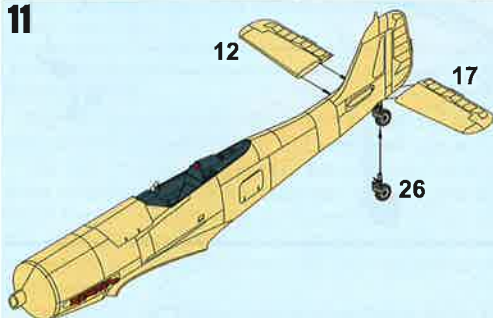
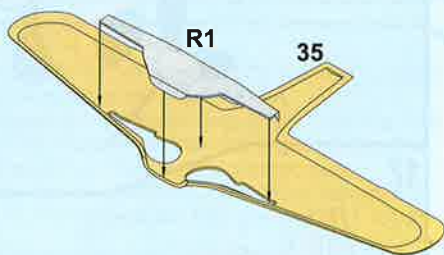
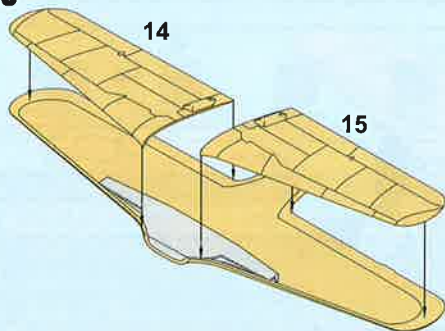
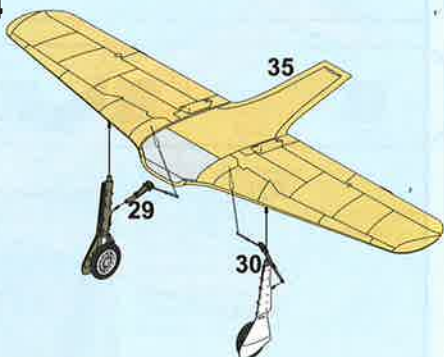
9**10****11****12****13****14**

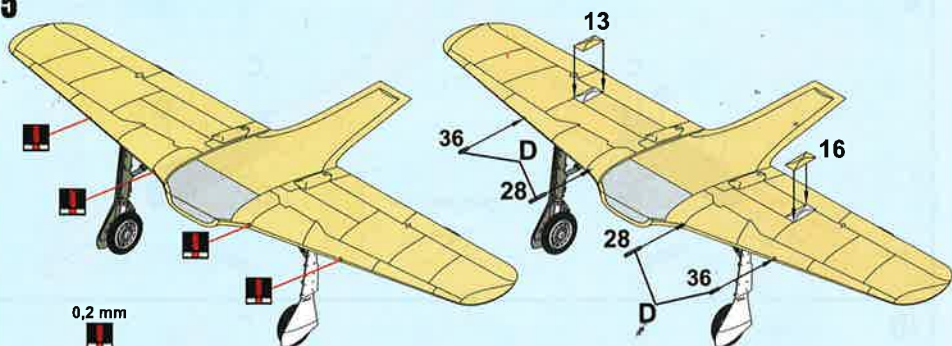
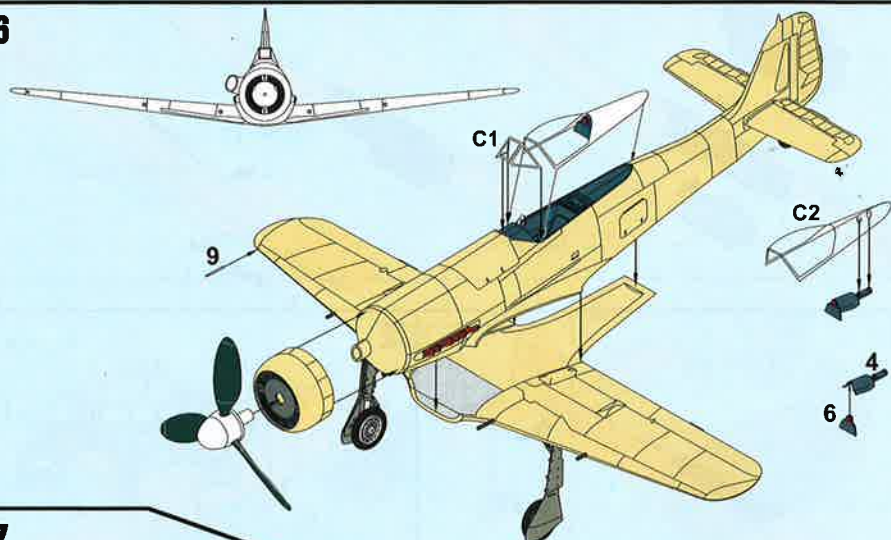
15**16****17**