



# US Army Heavy Type II Skid Steer Loader (M400T)



1/35

35GM0010

1

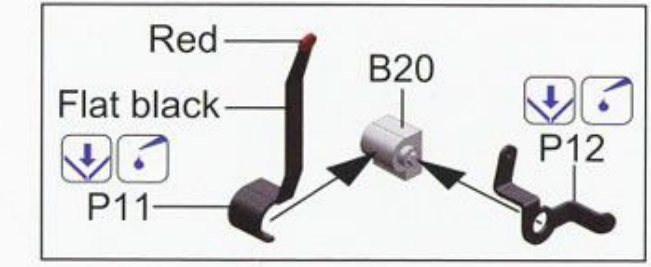
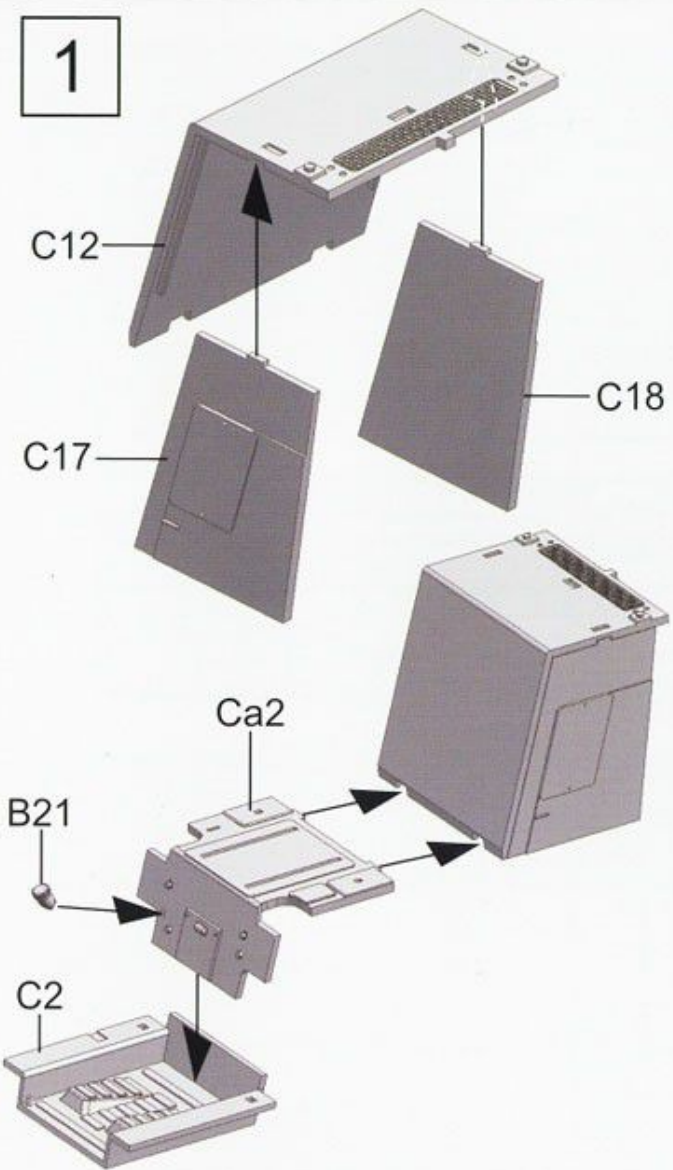

2

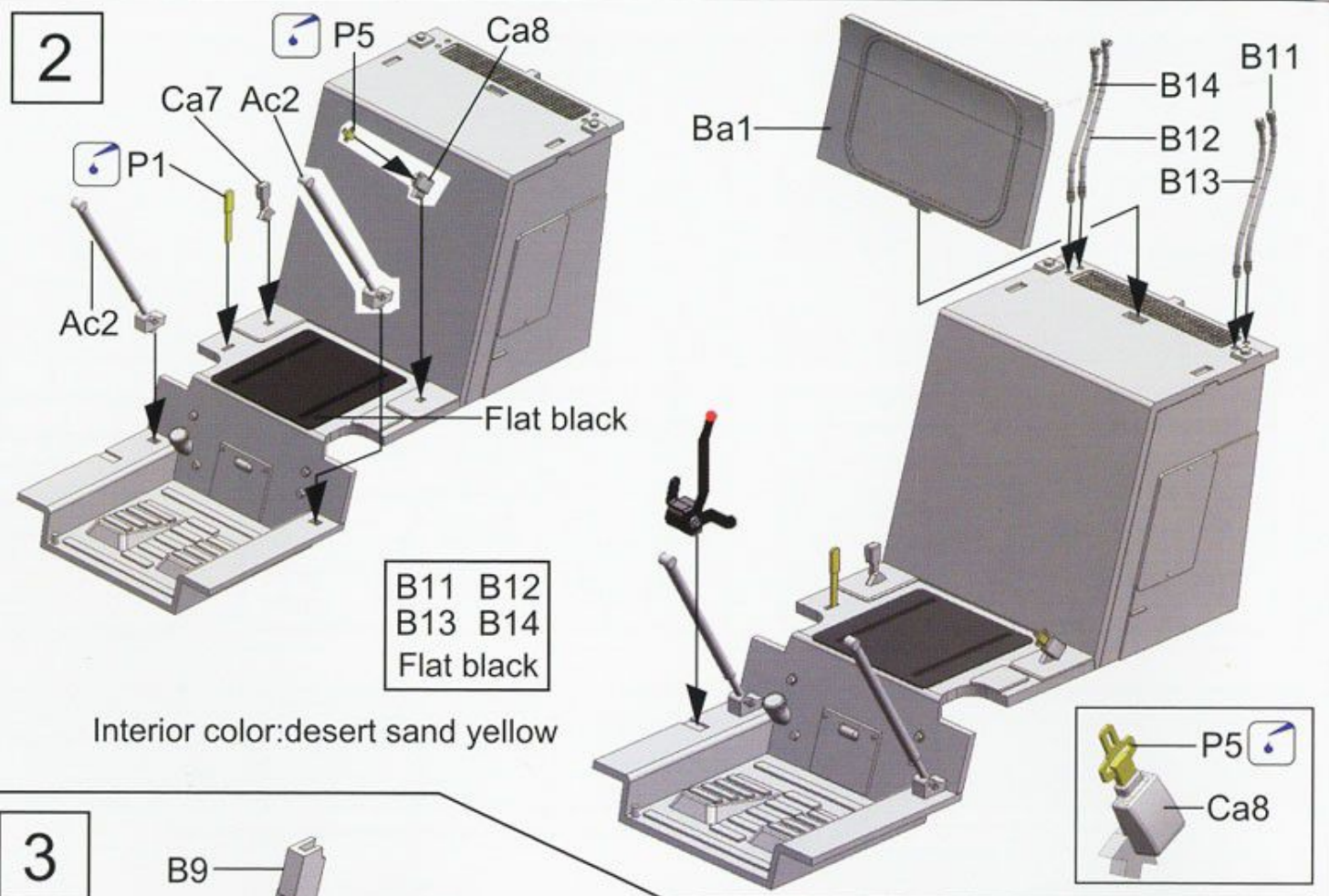

3

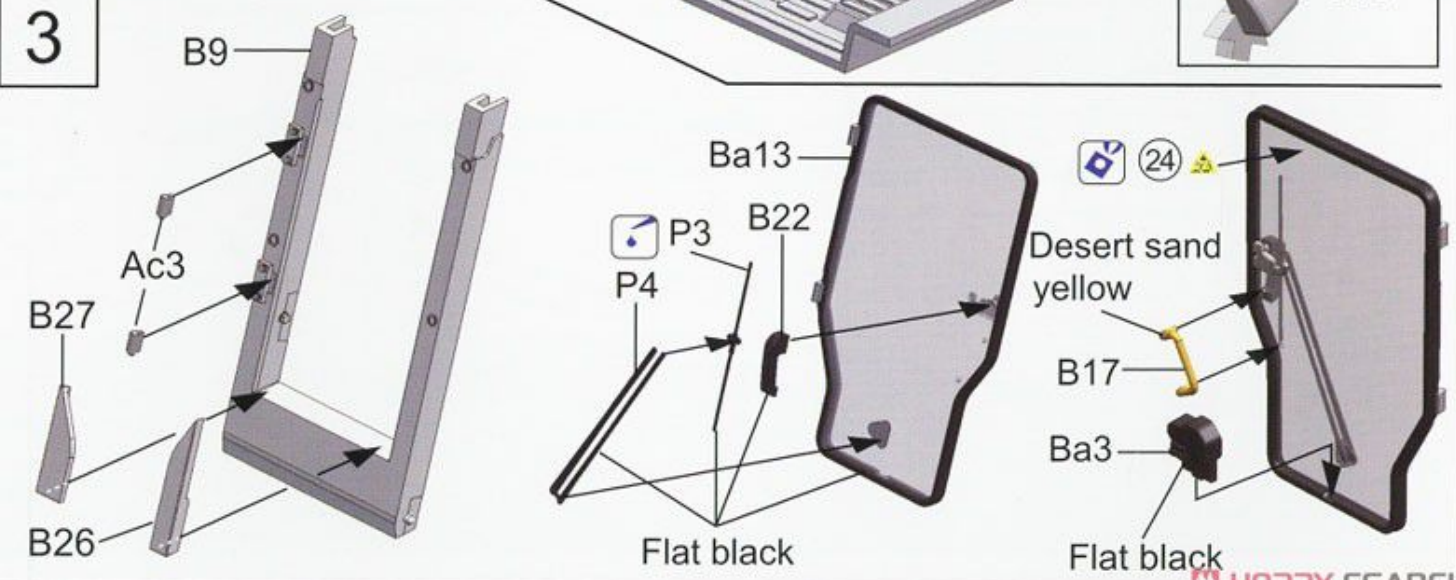

4

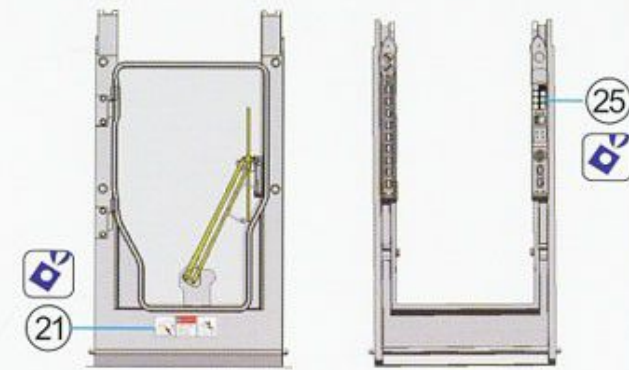
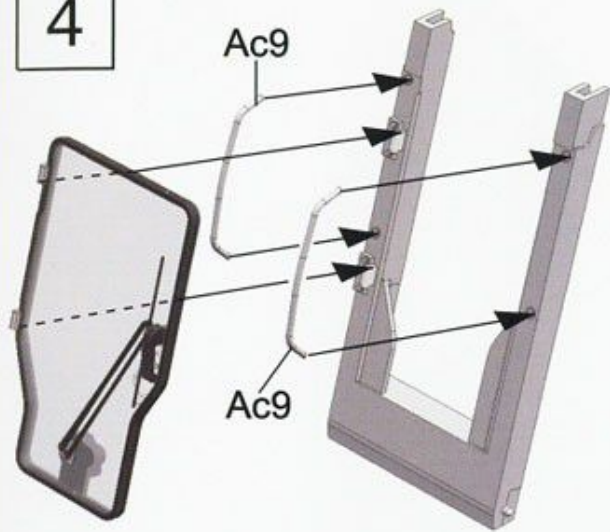

Interior color:desert sand yellow

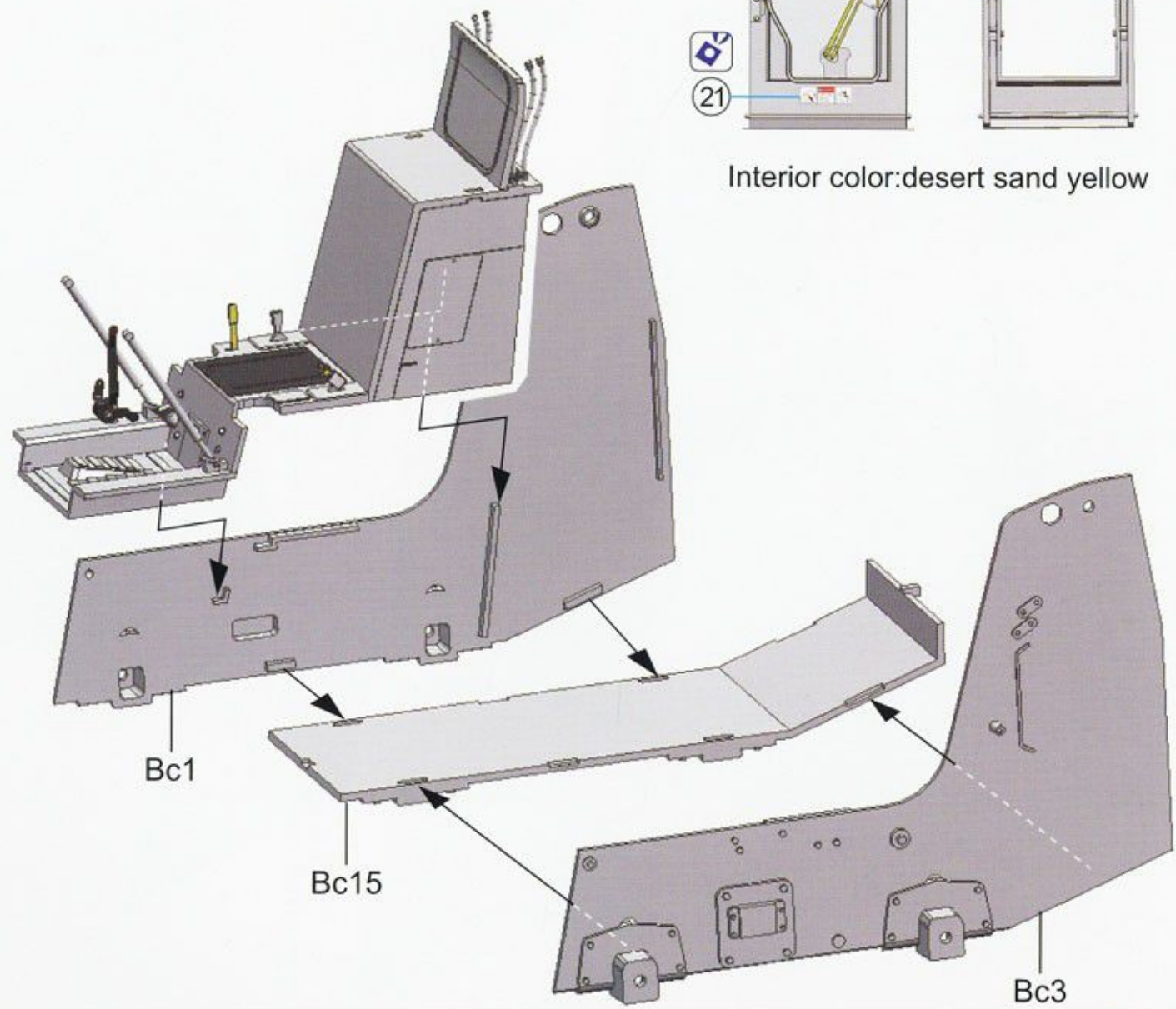
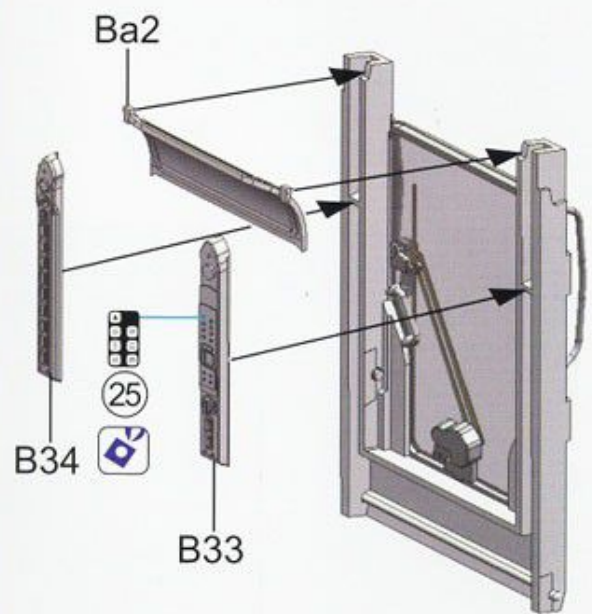

5

5

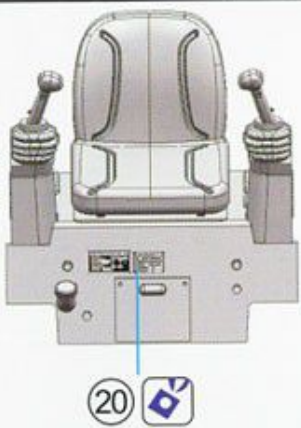
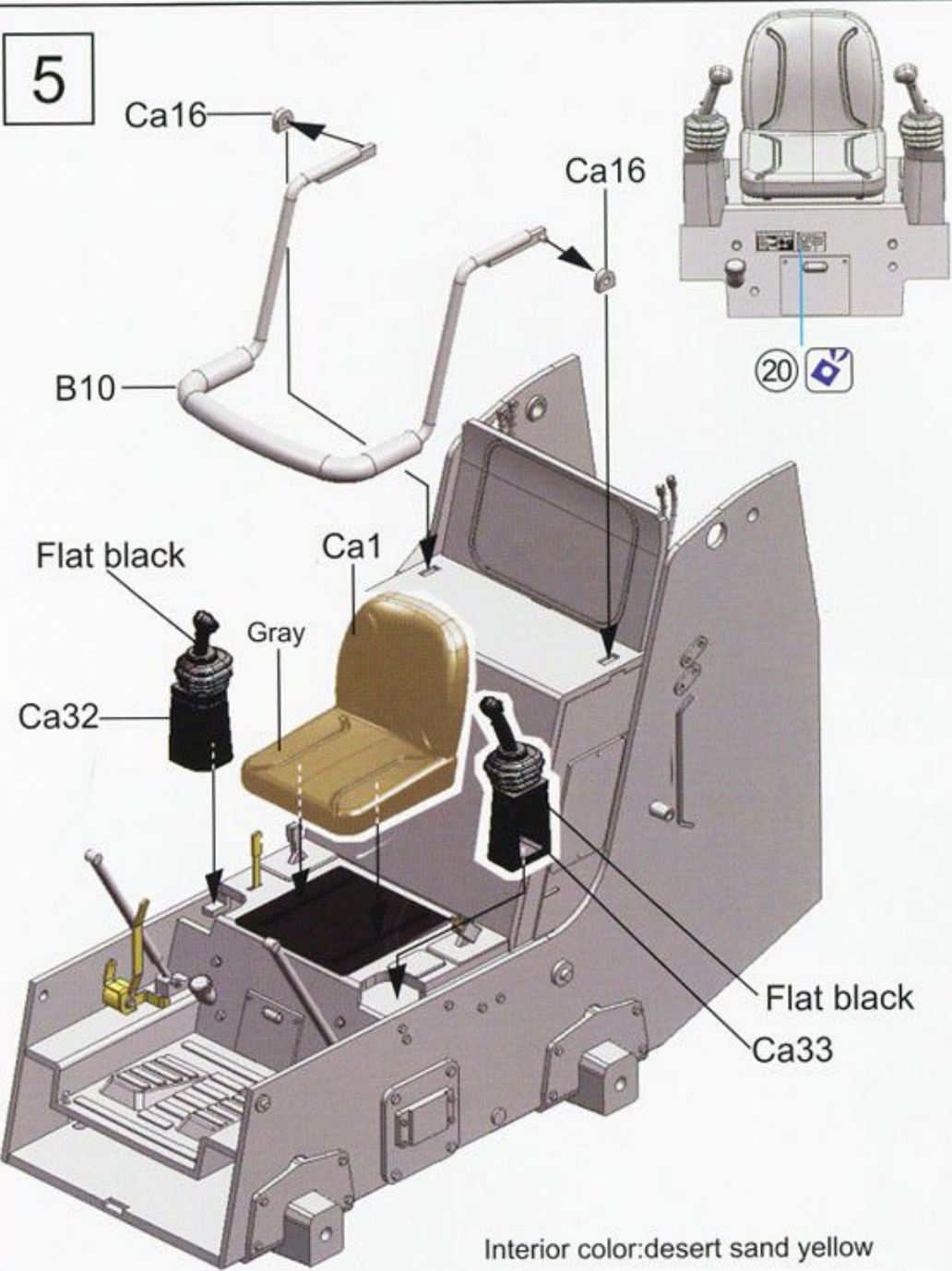

6

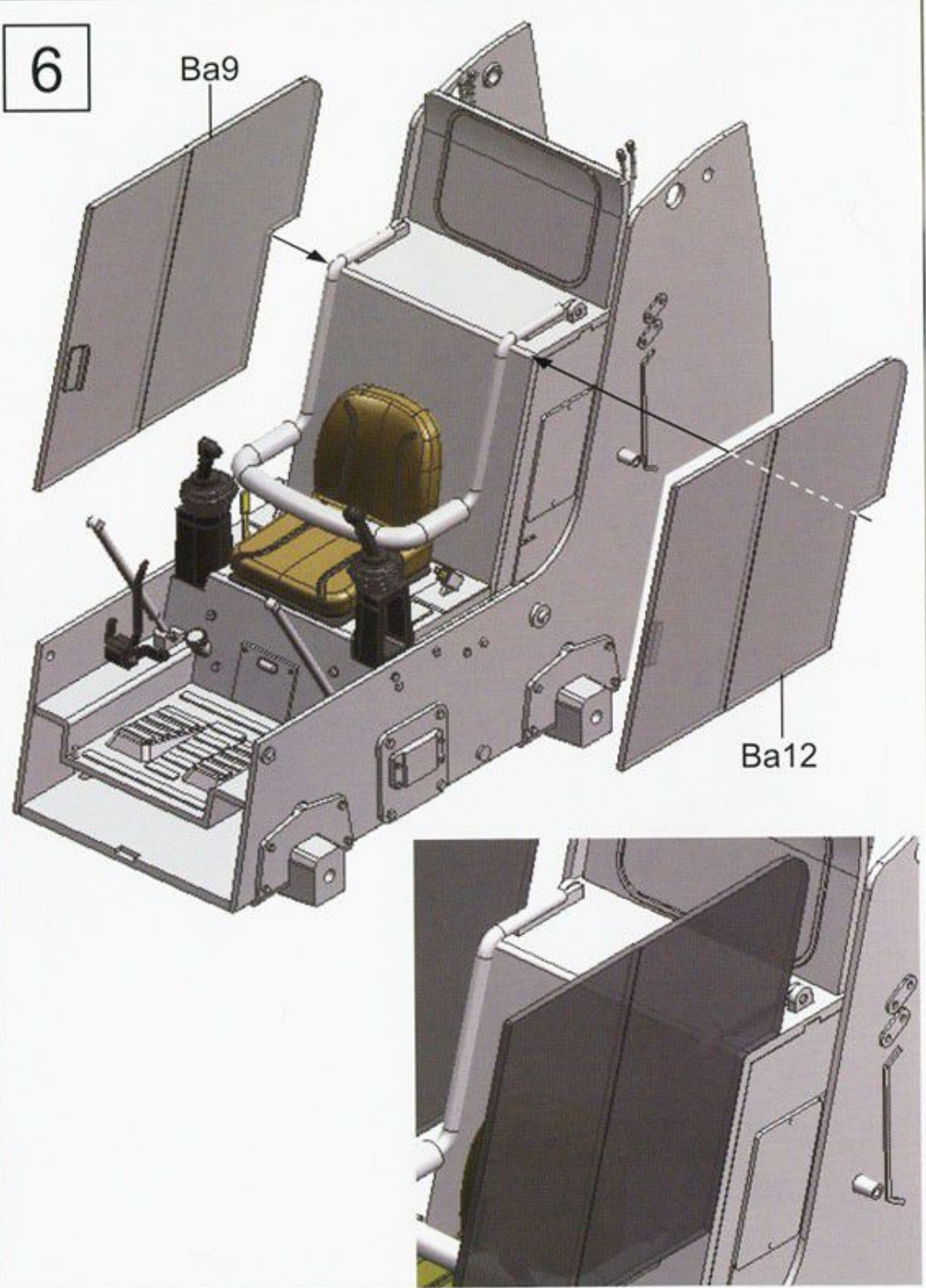

7

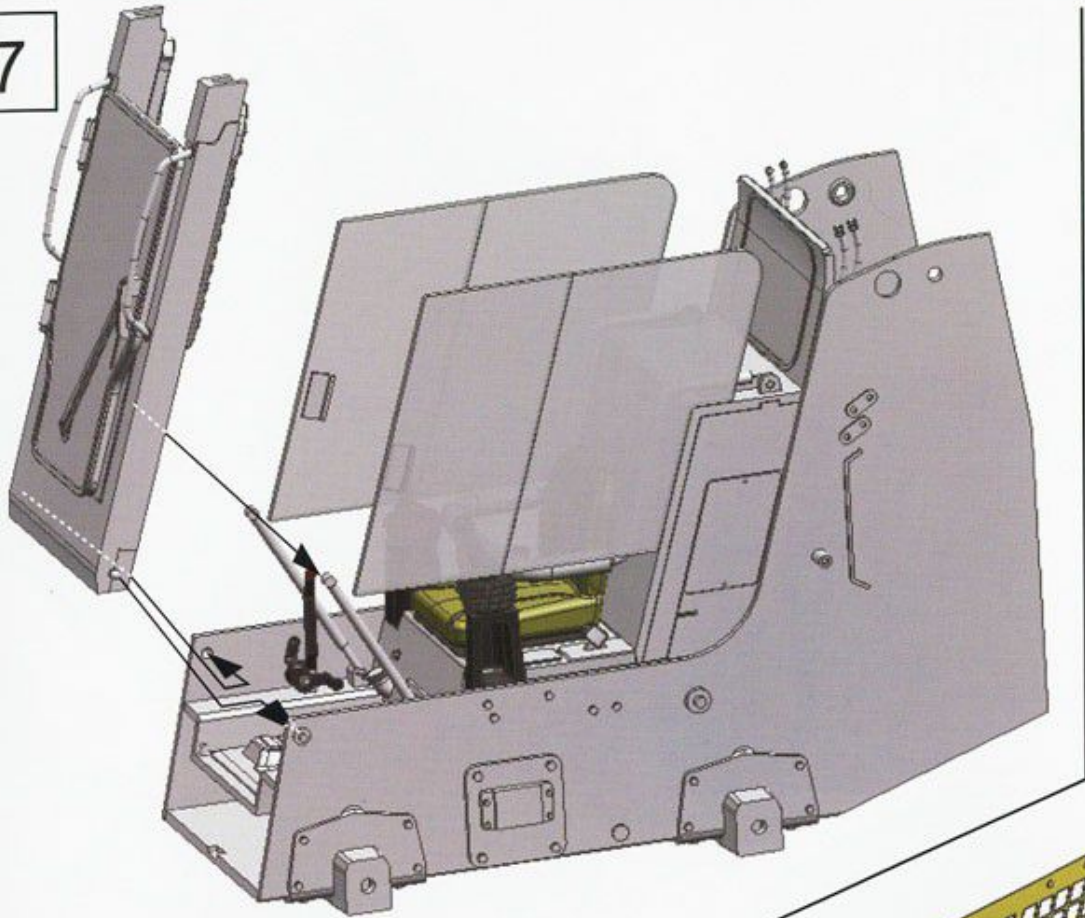

8

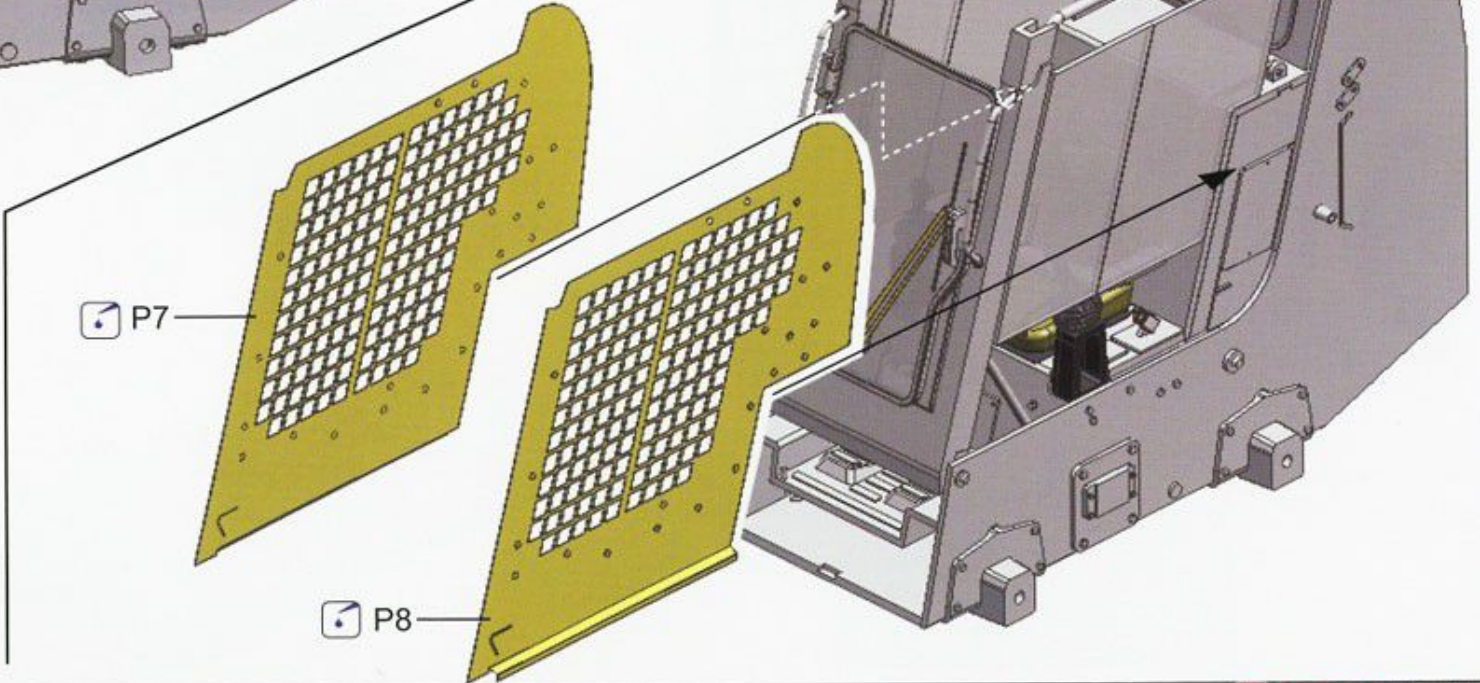
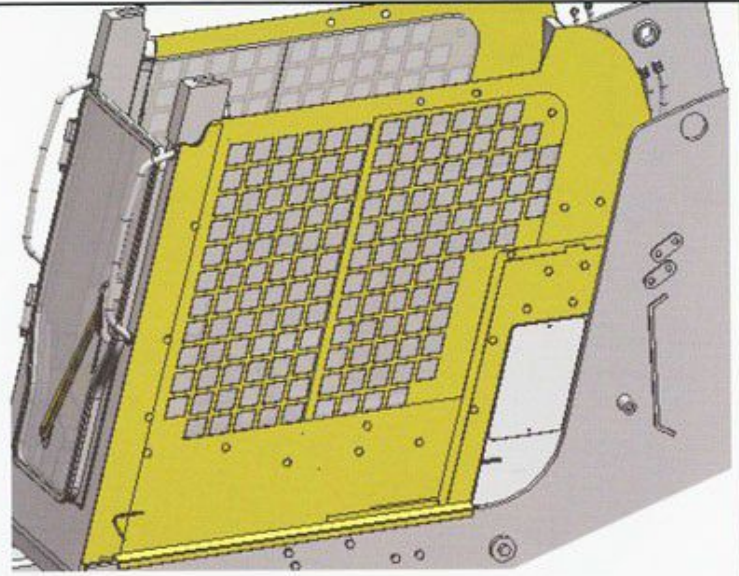

P7

P8

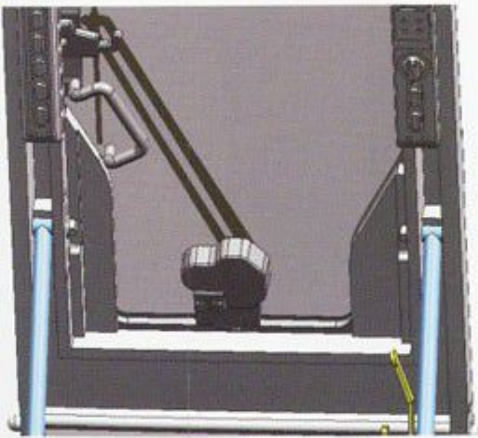

9

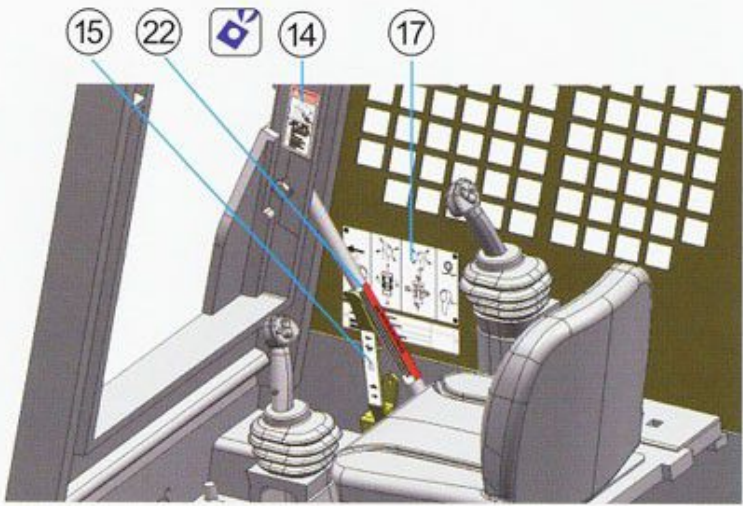
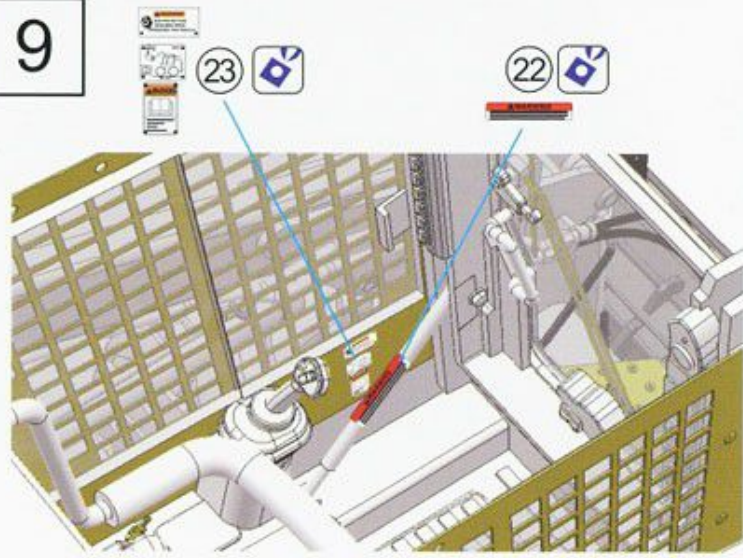

10

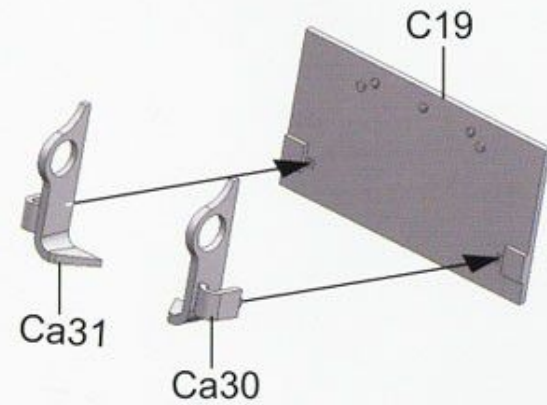
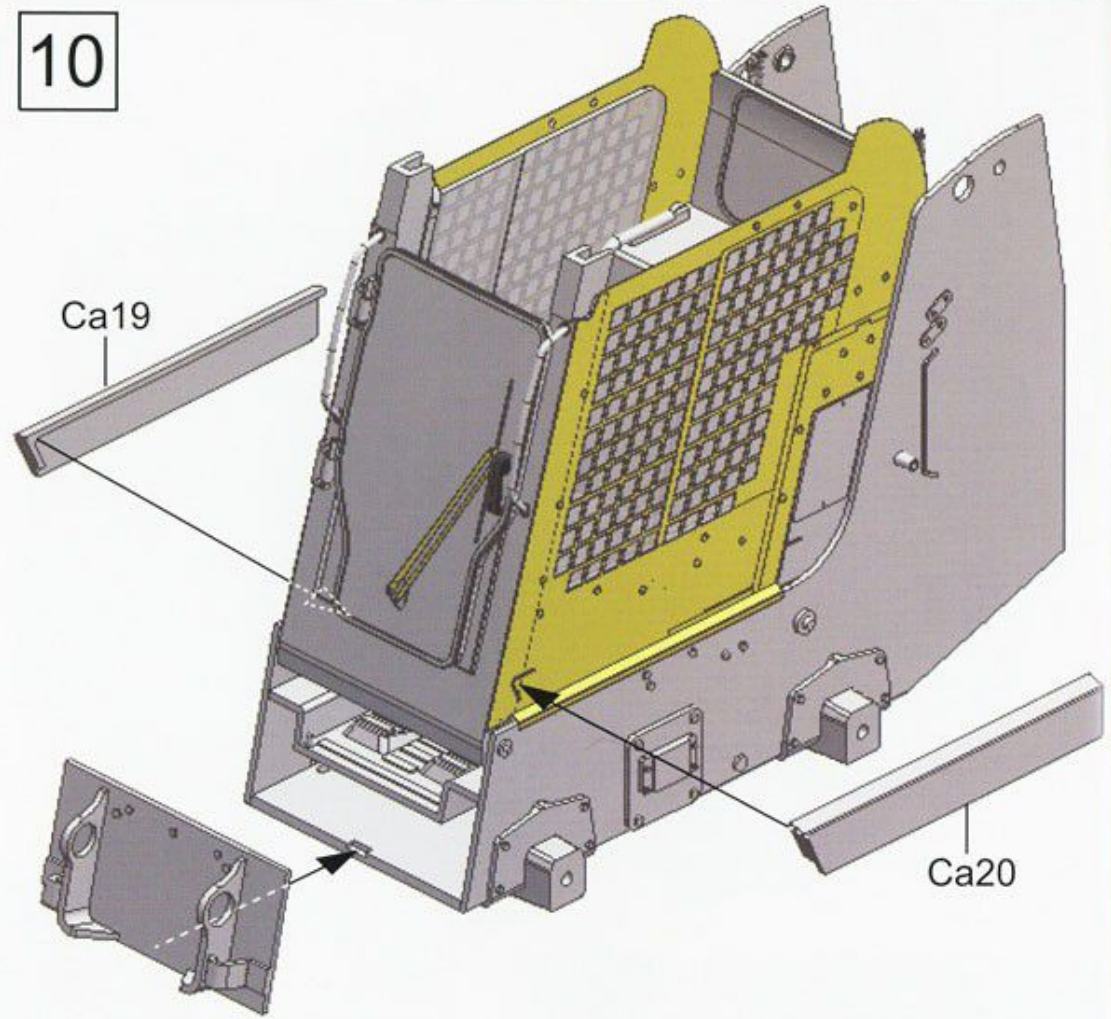

11

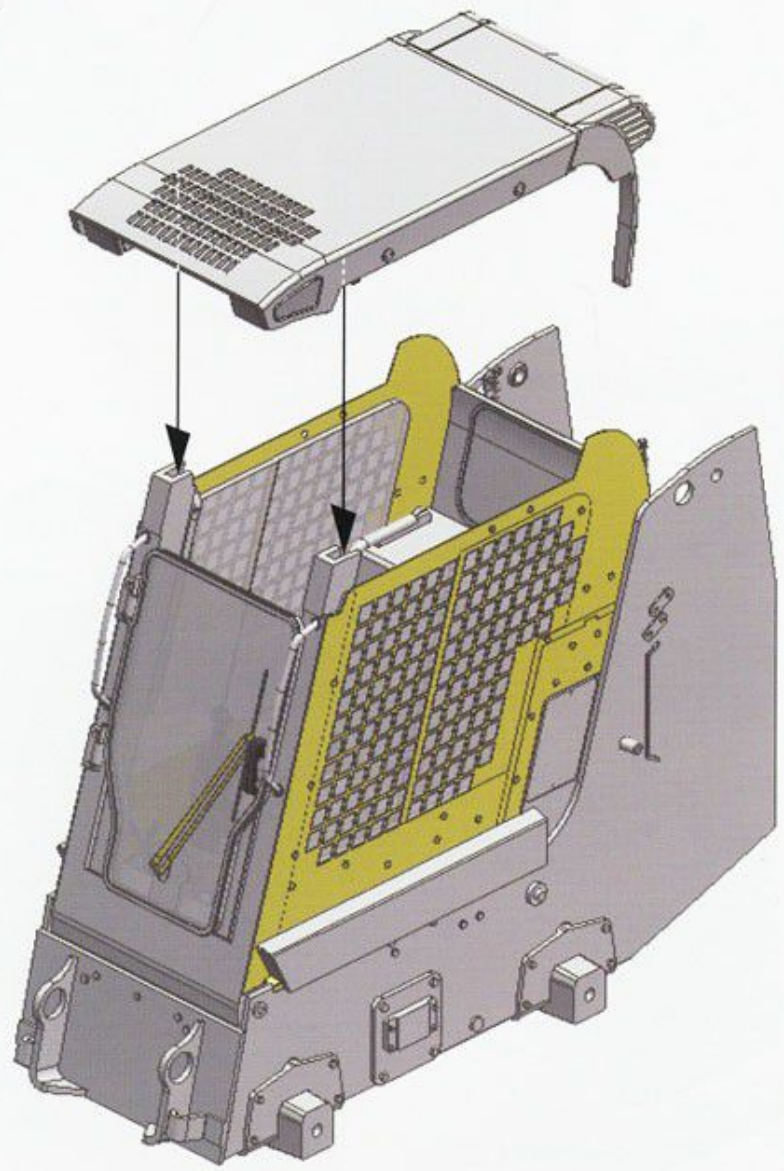
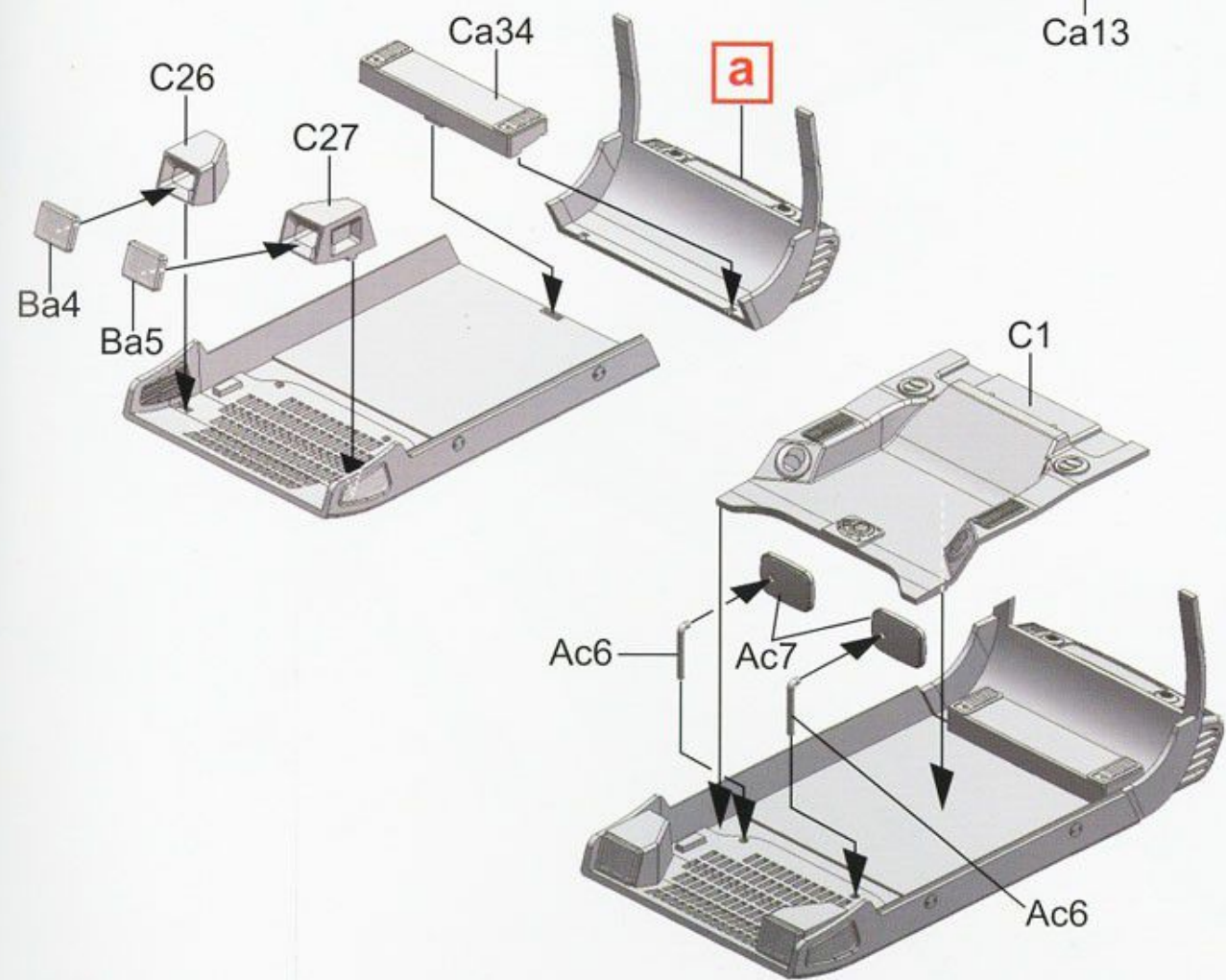
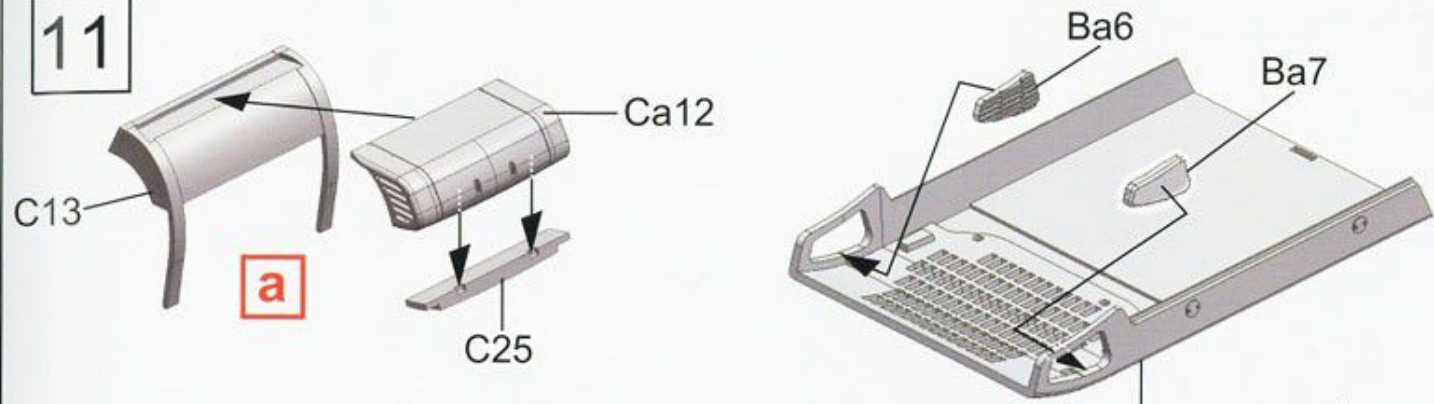

12

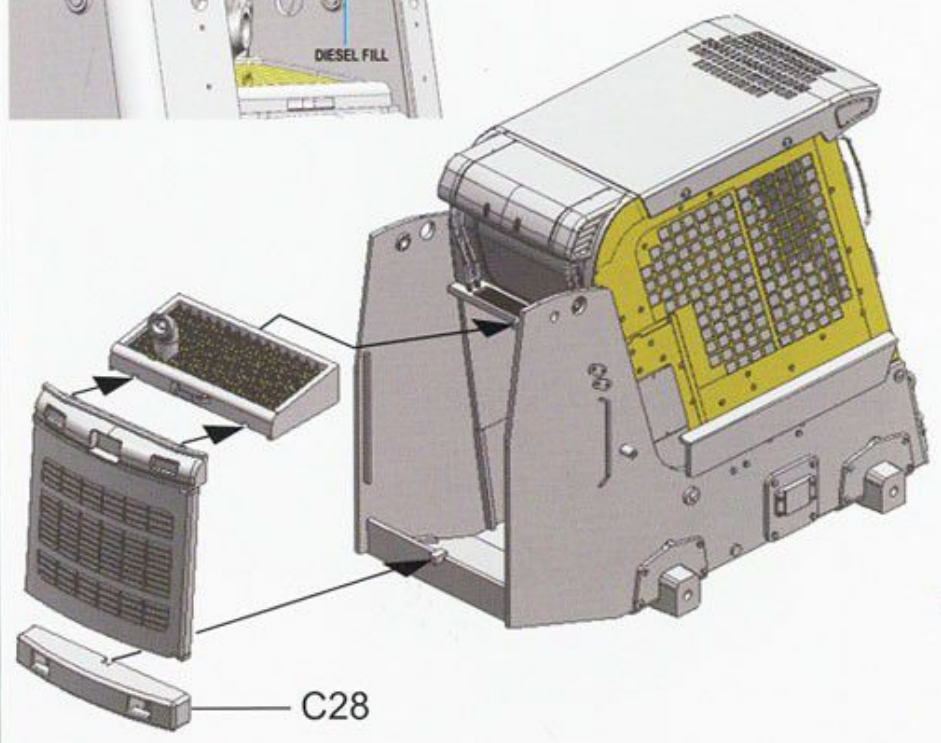
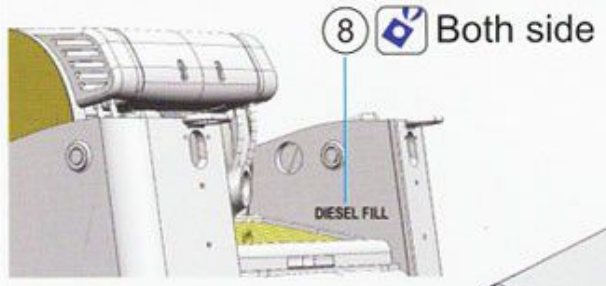
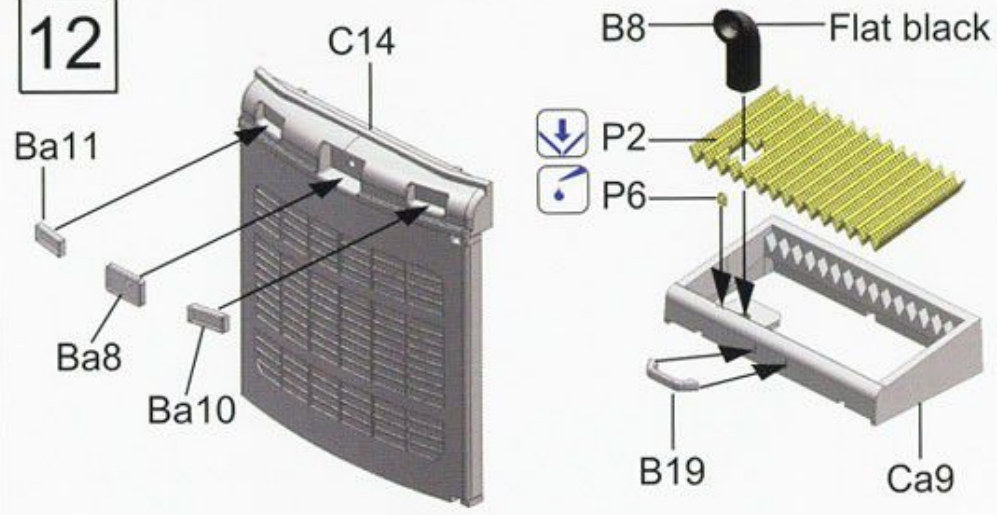

13

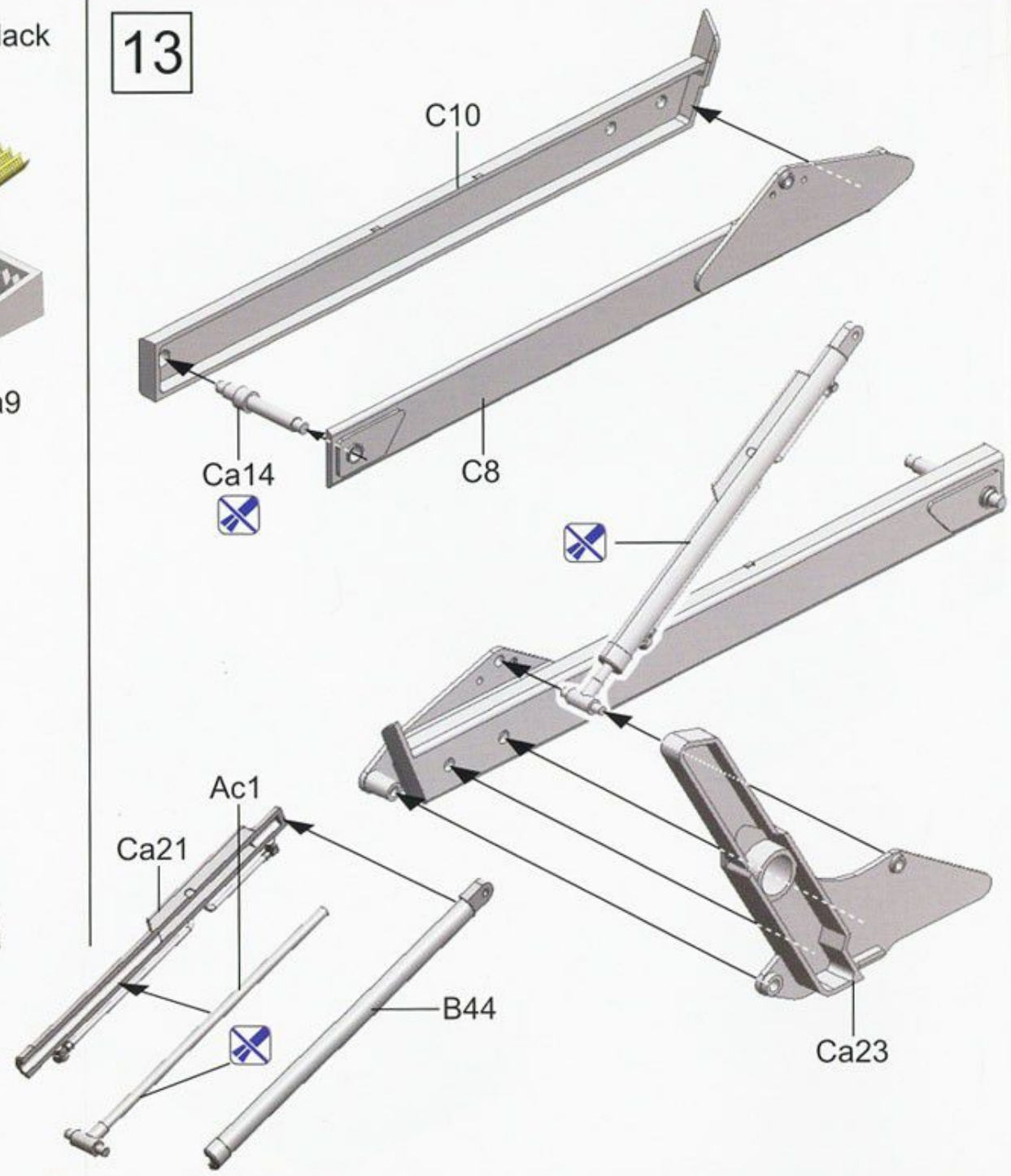



14

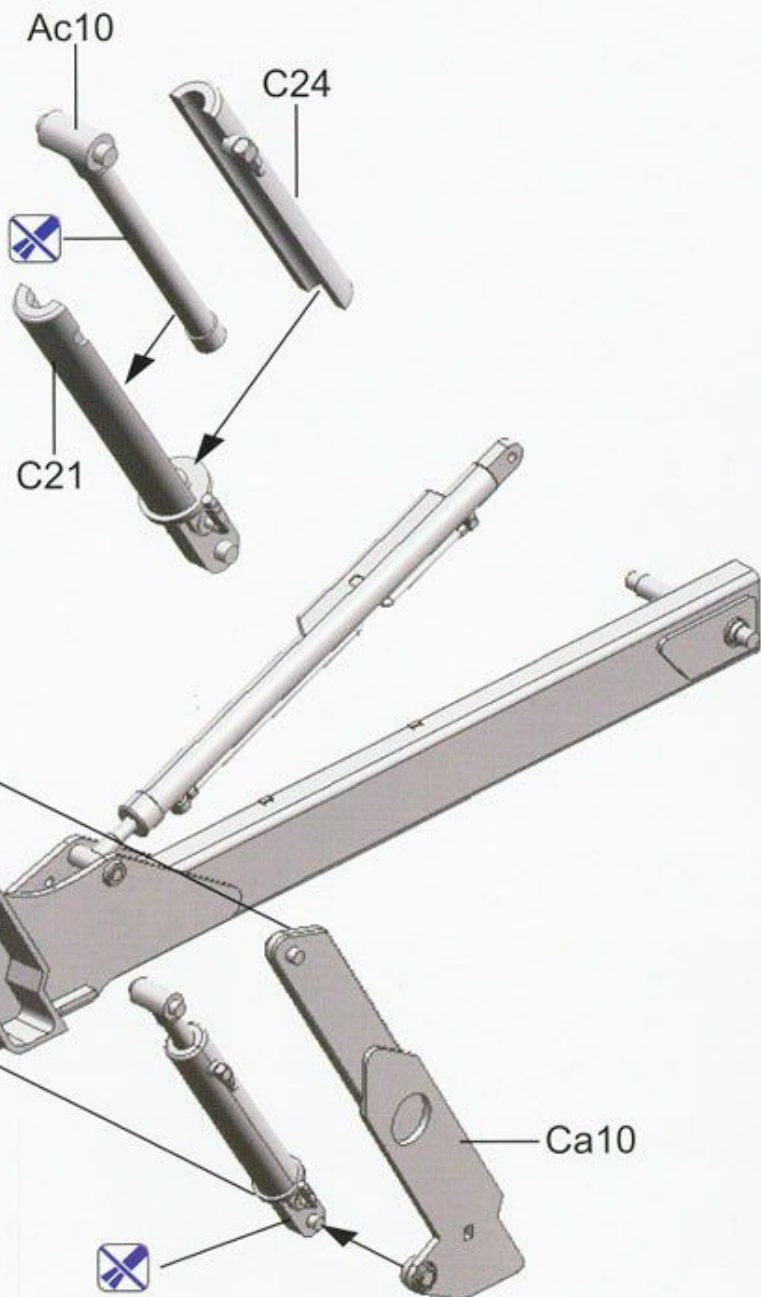

15

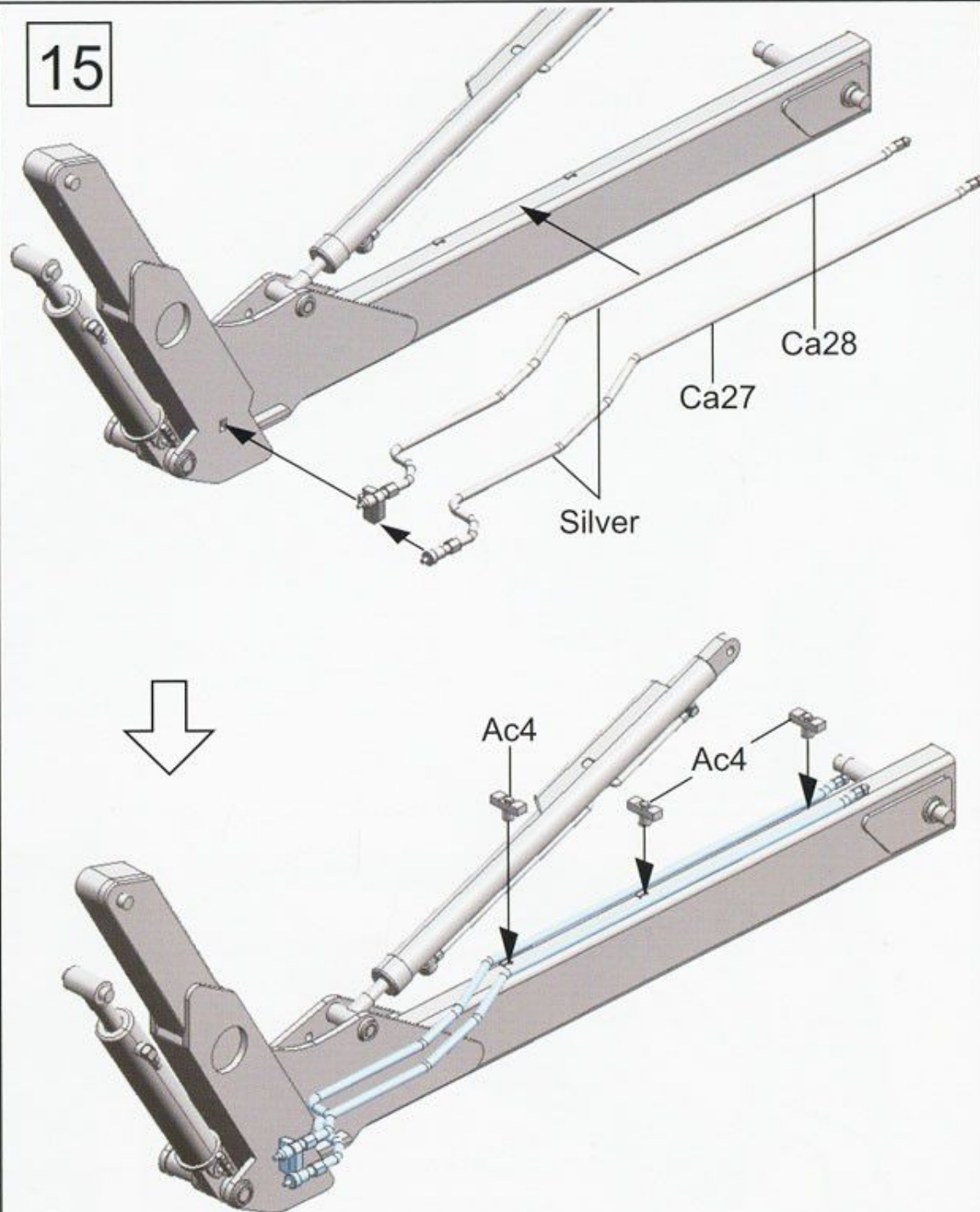

16

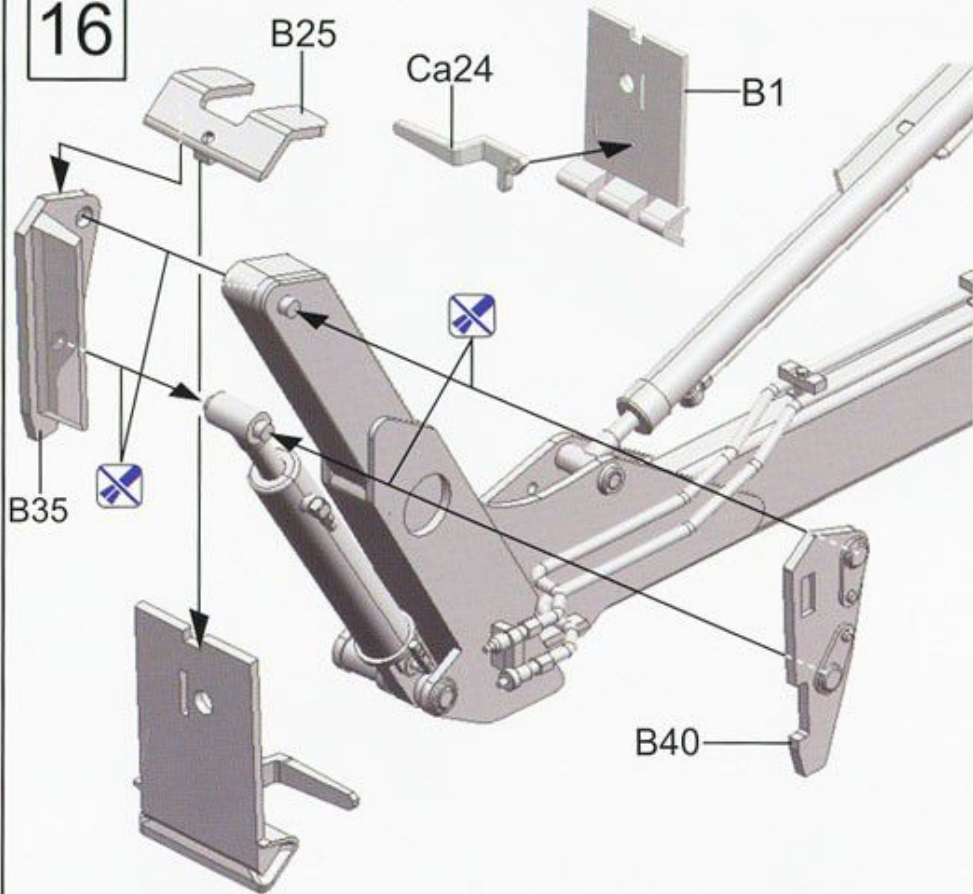

17

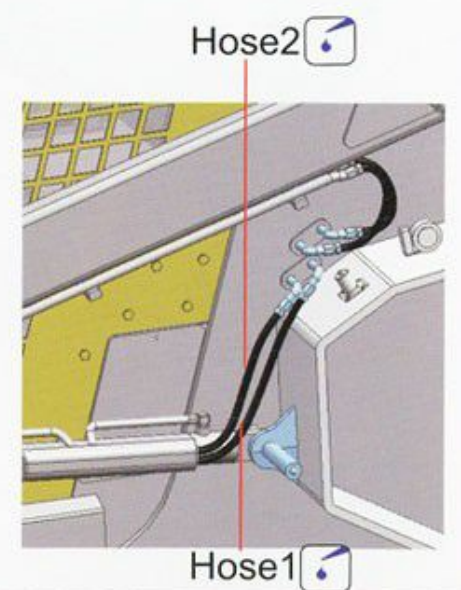
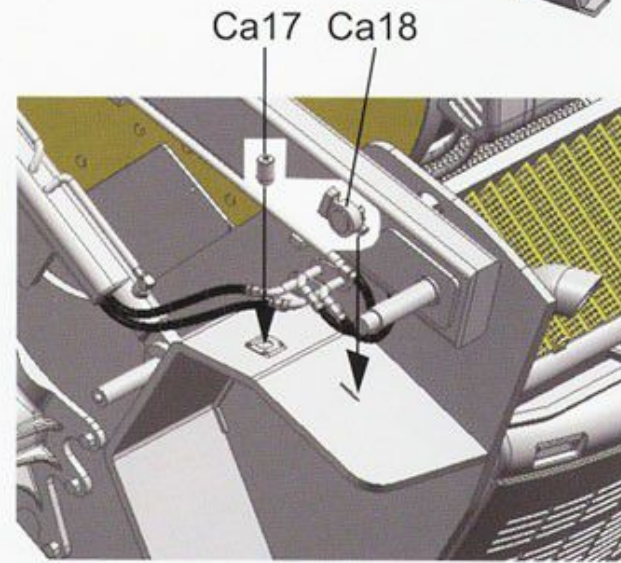
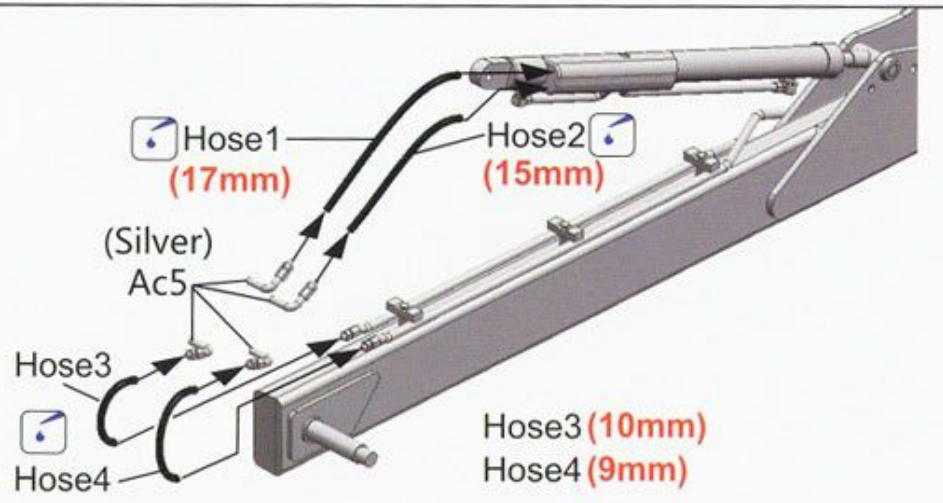
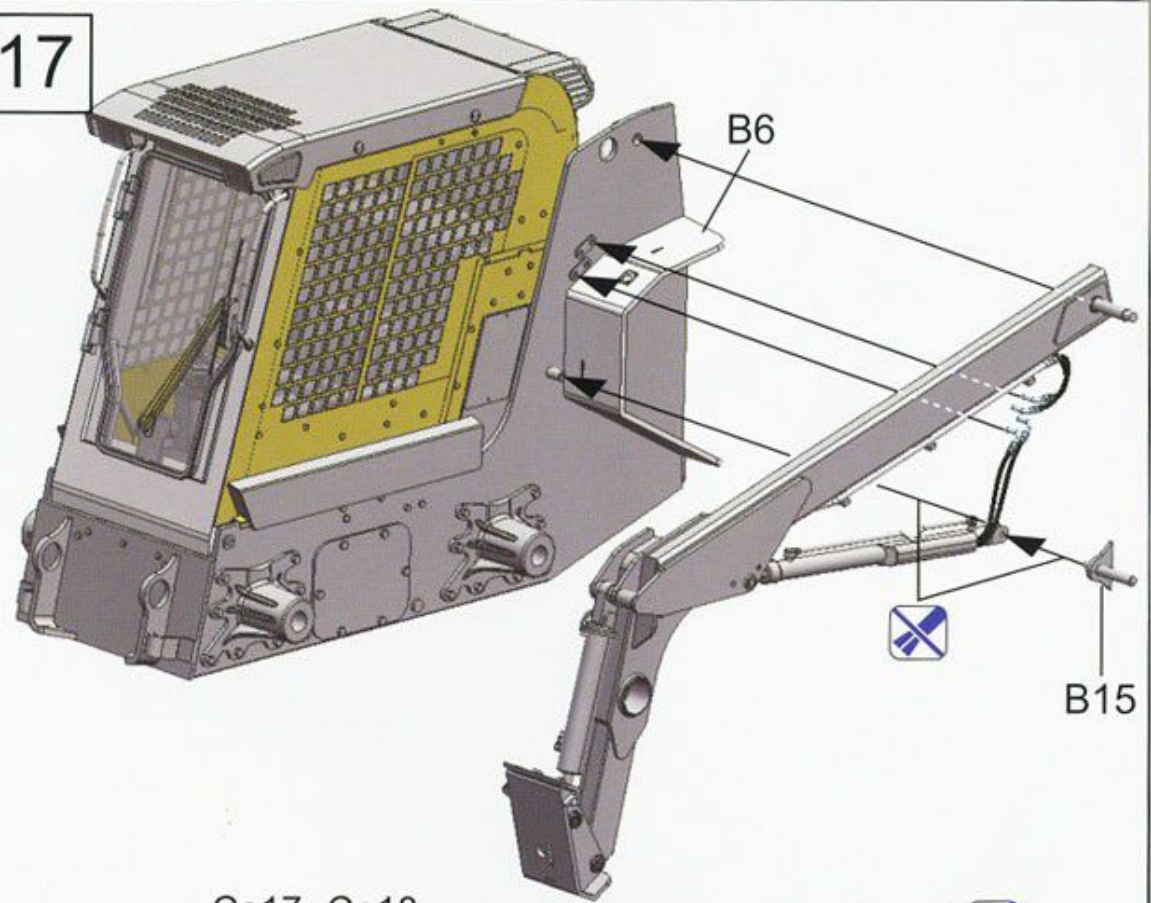

18

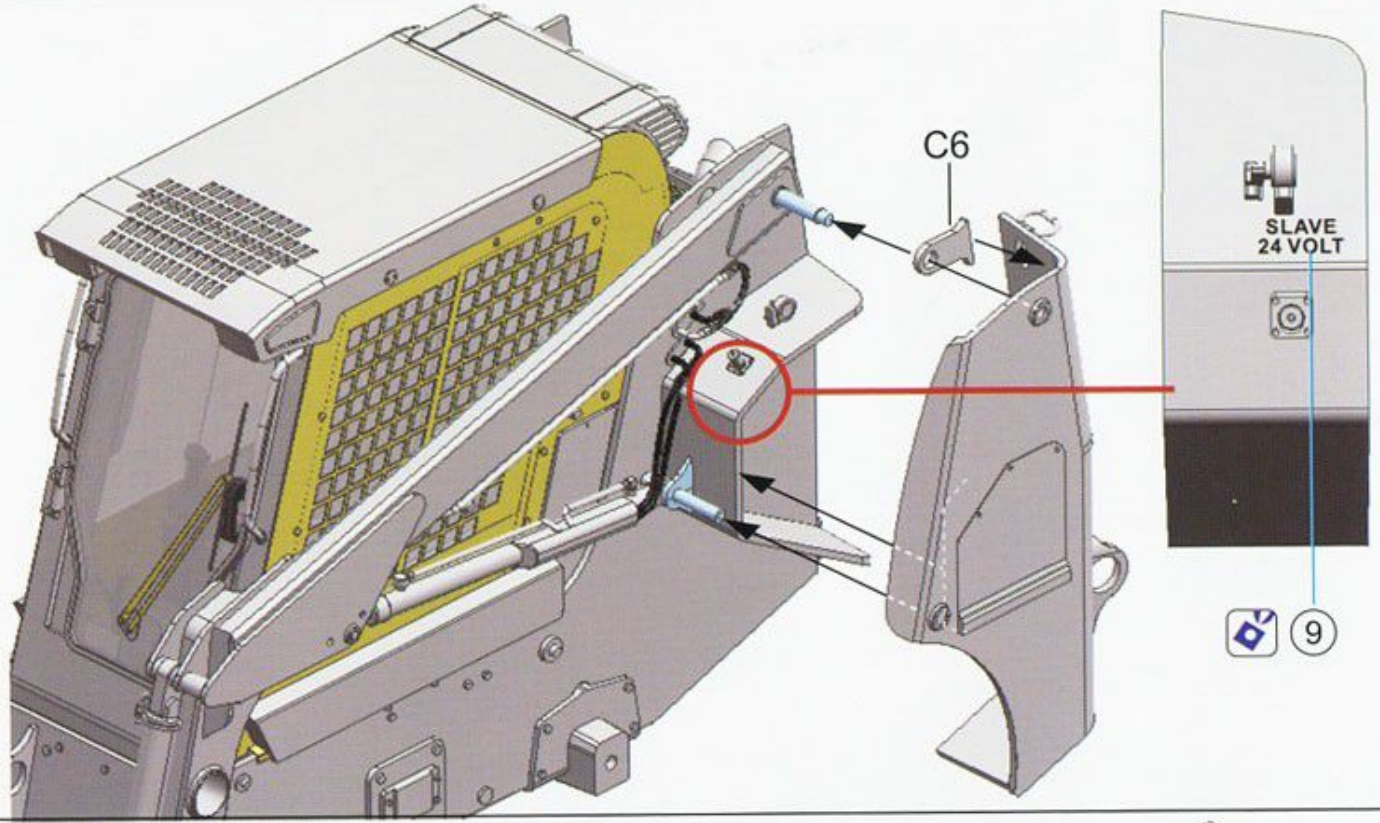
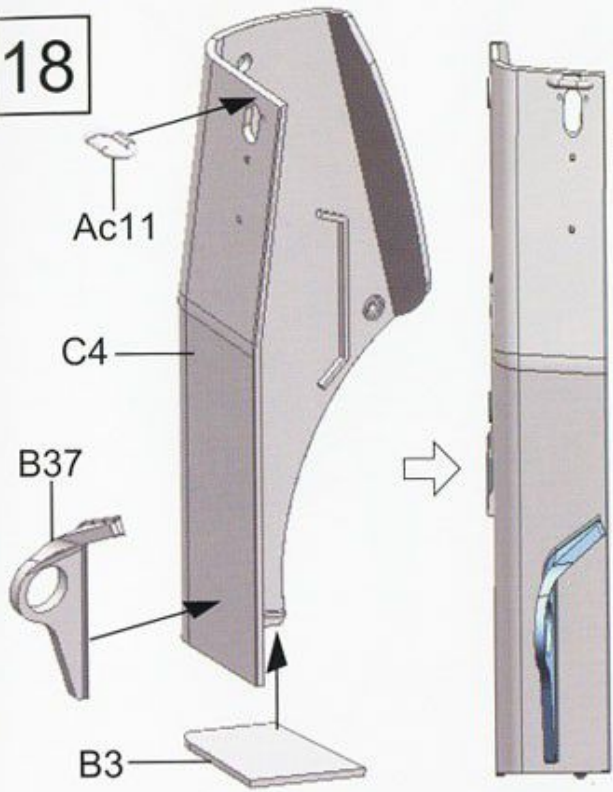

19

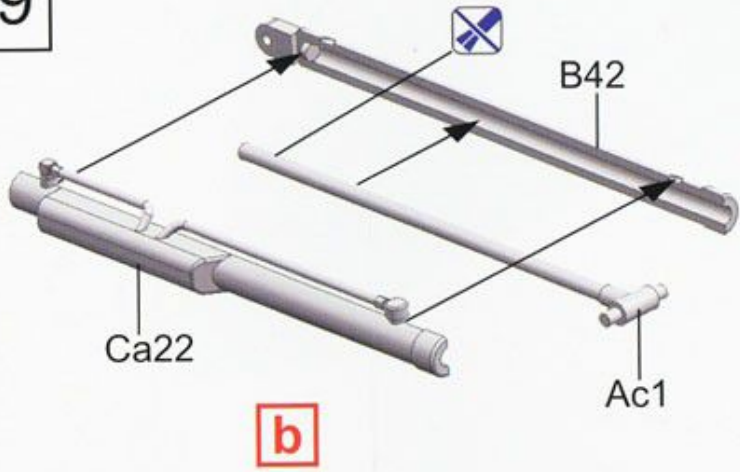

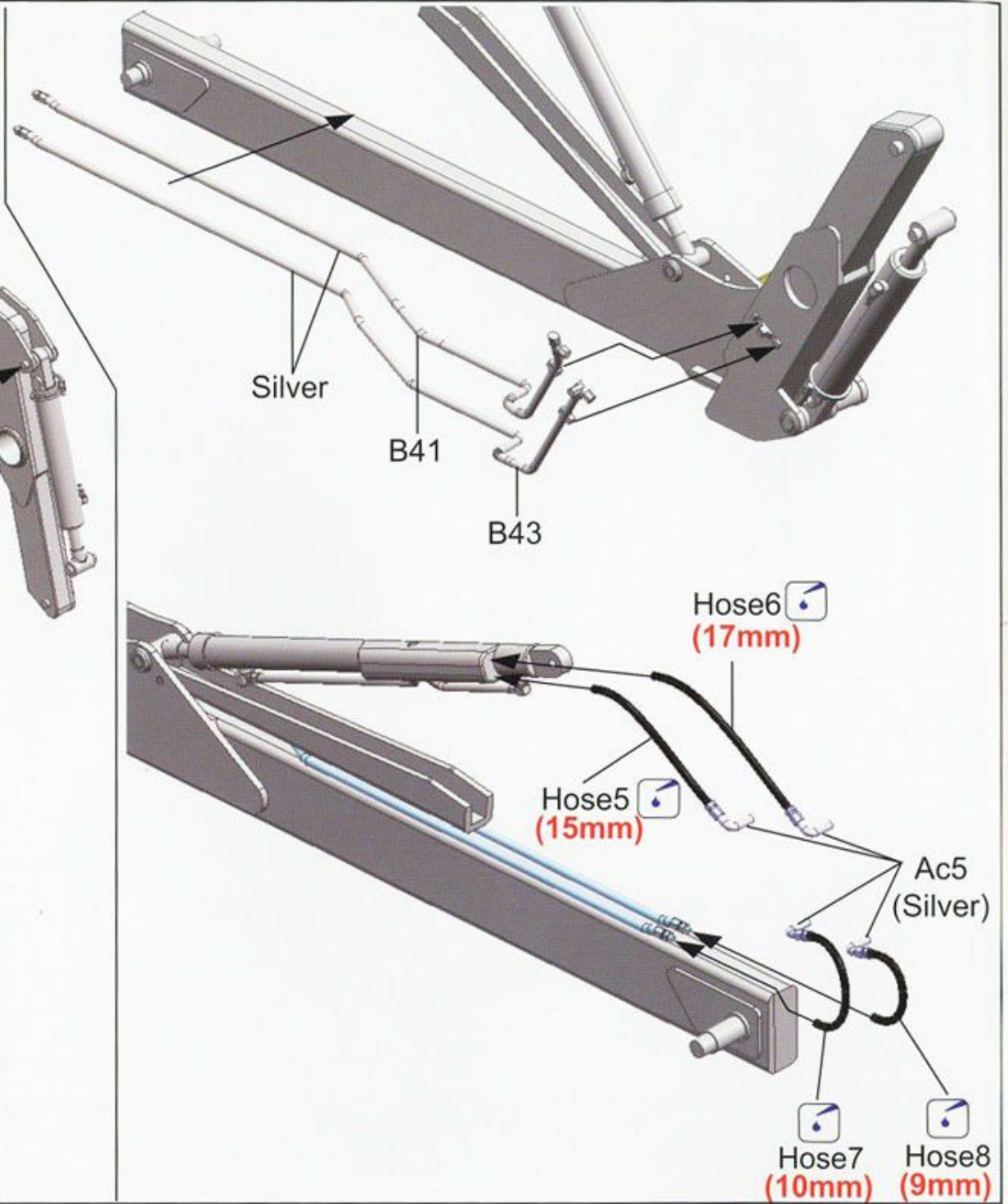
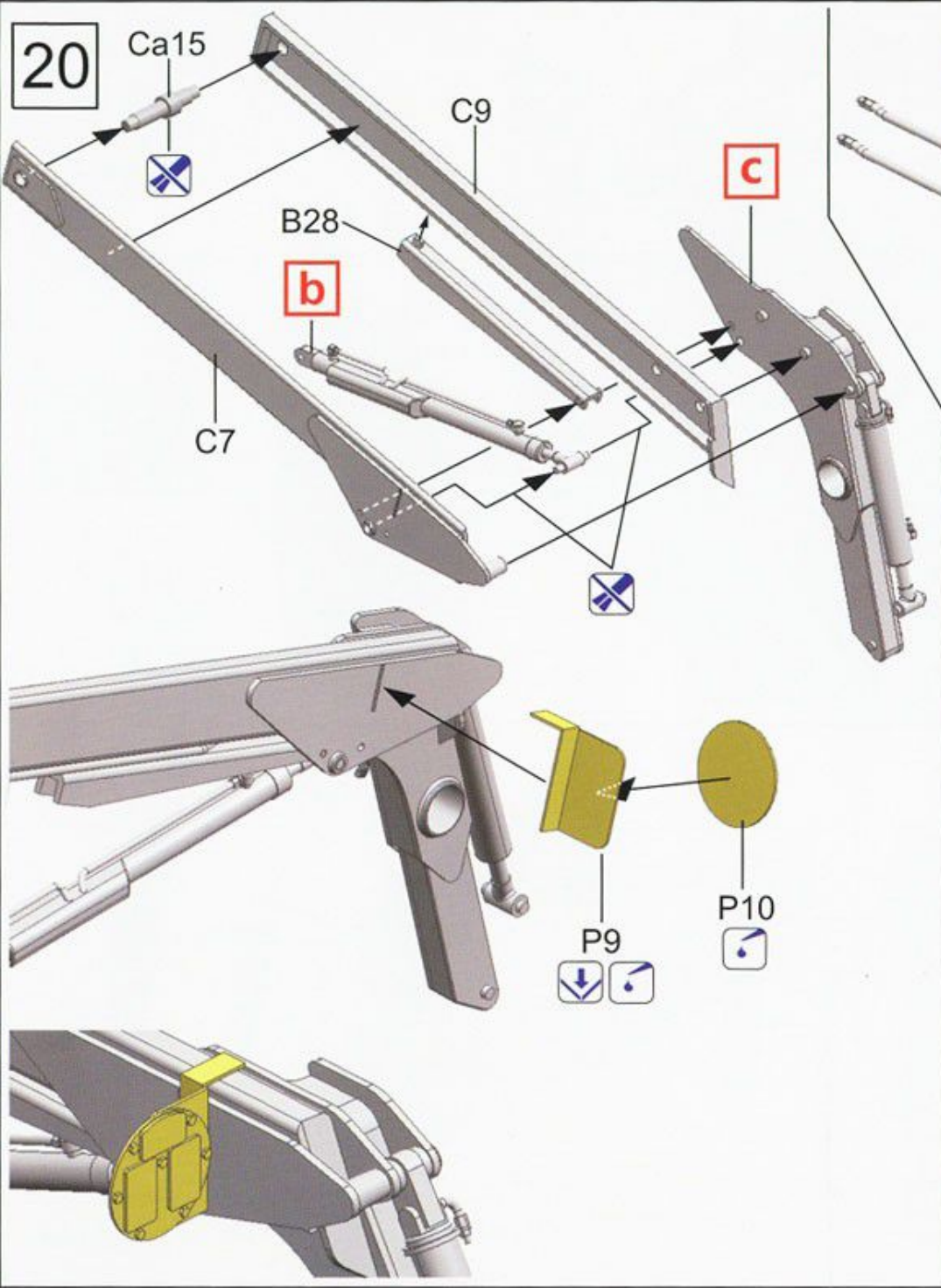

21

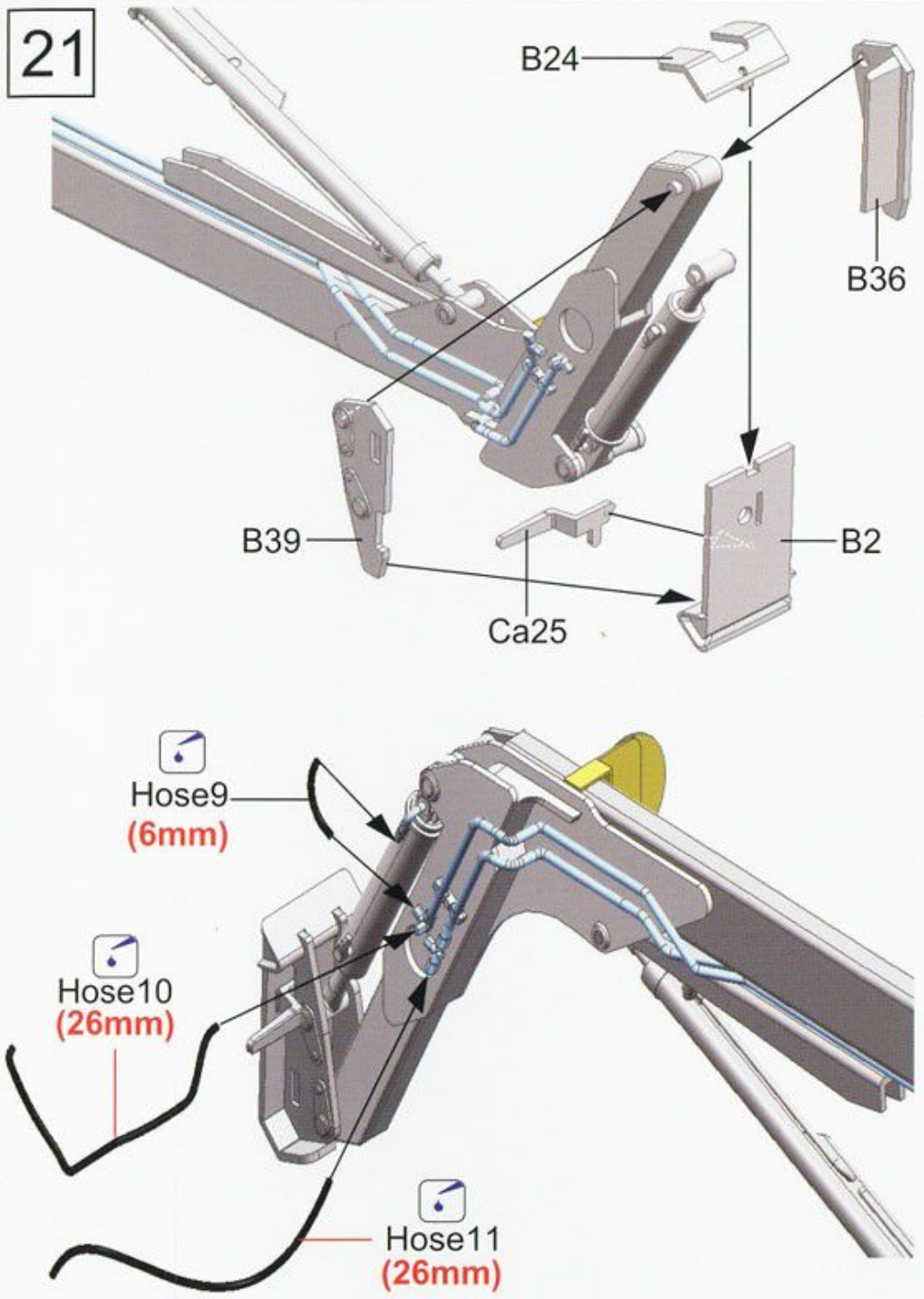

22

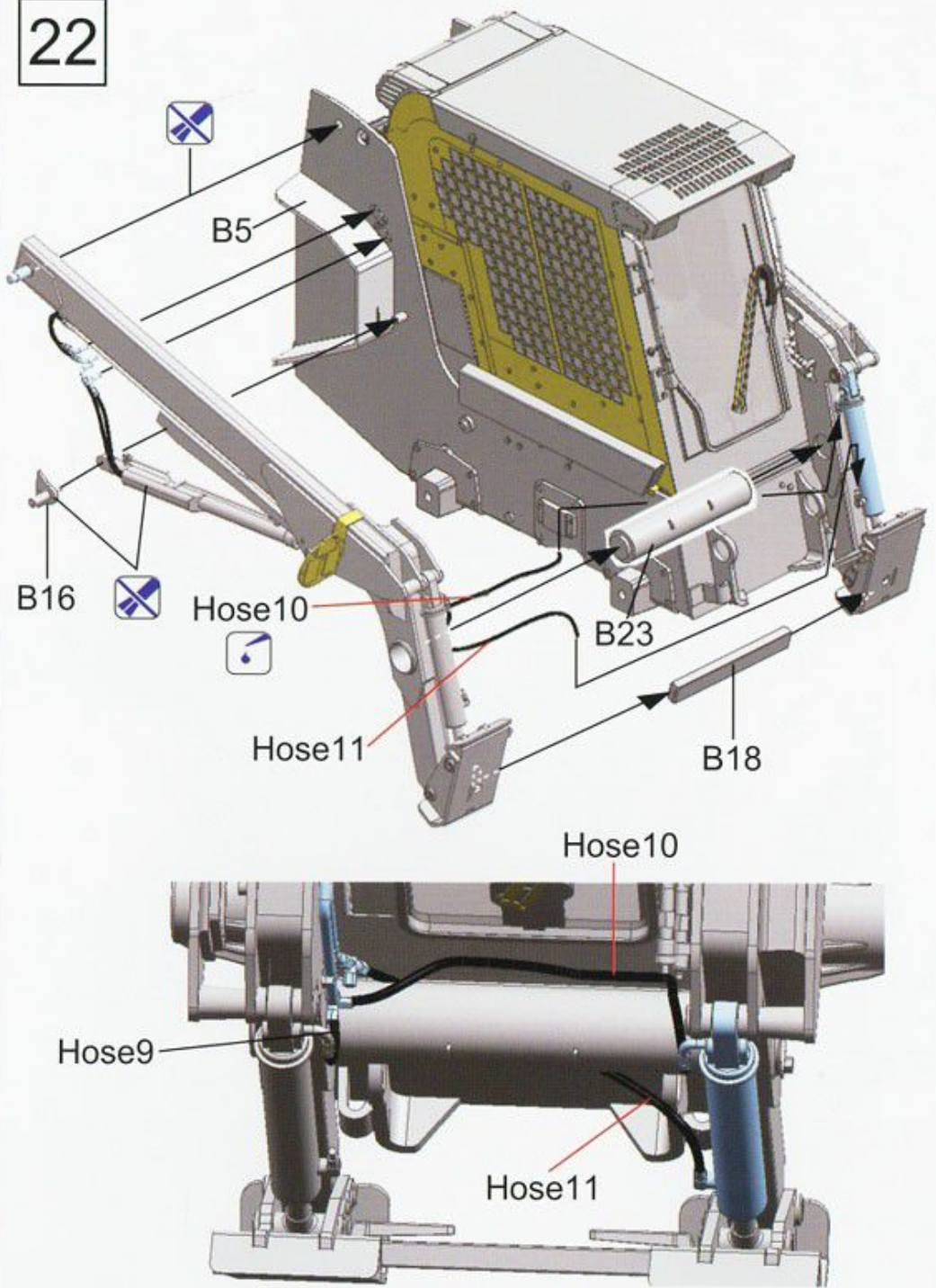

23

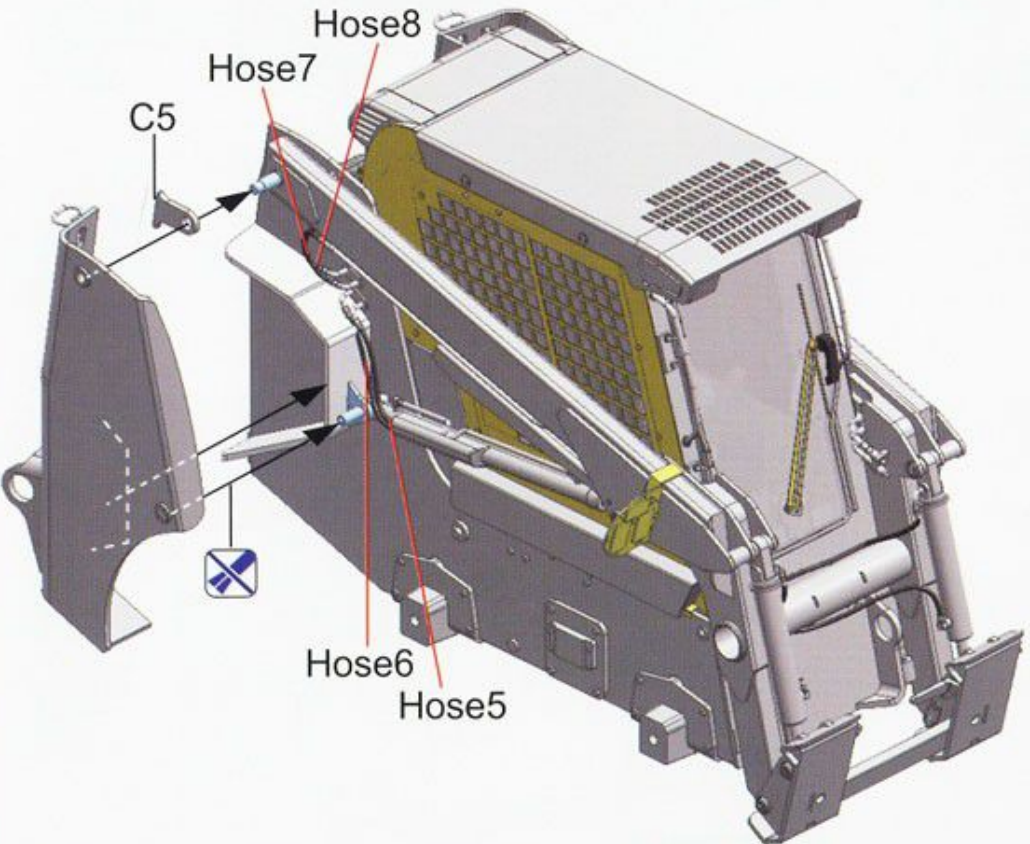
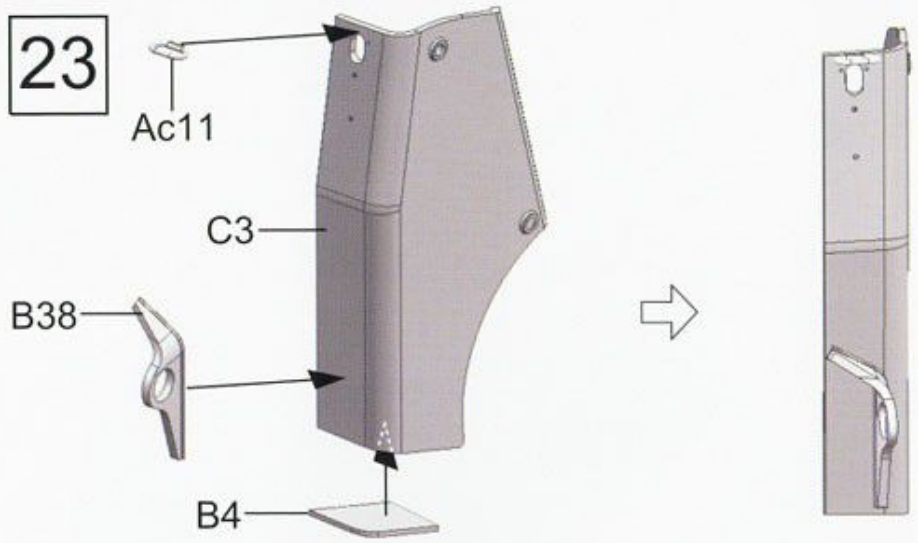

24

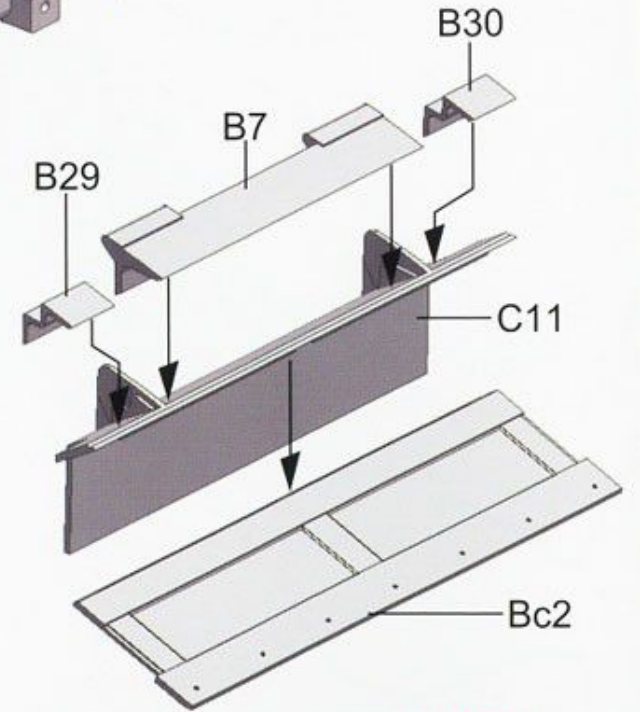
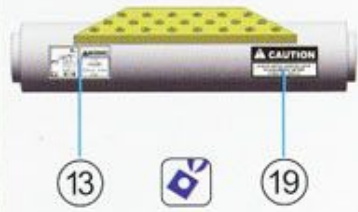
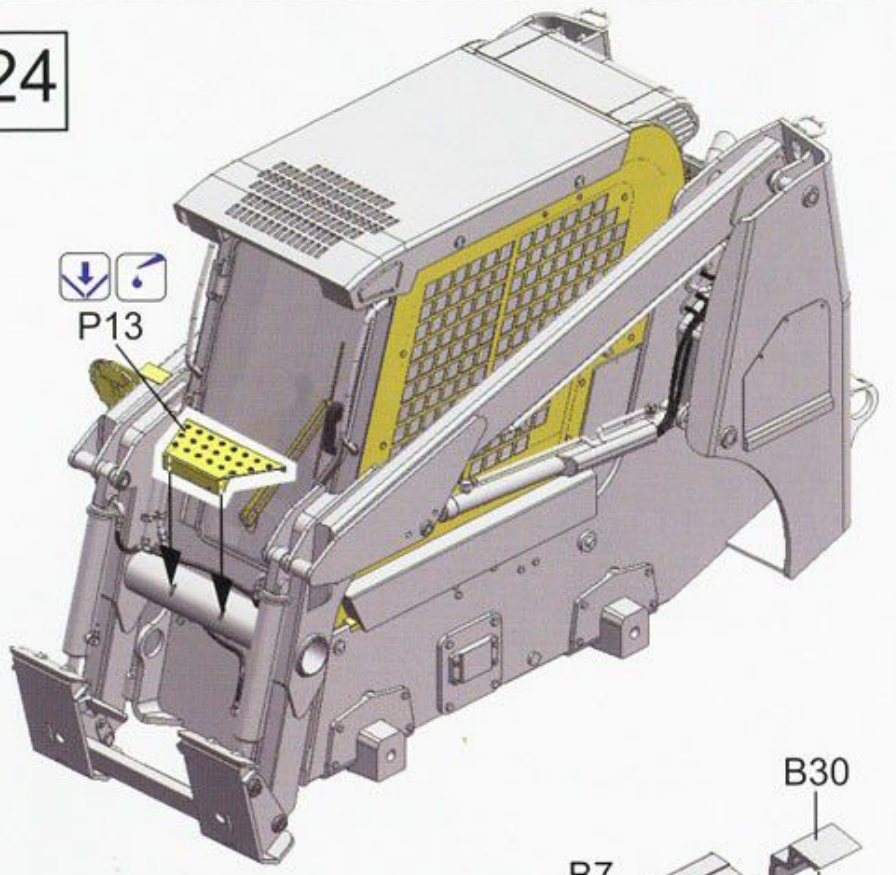

25

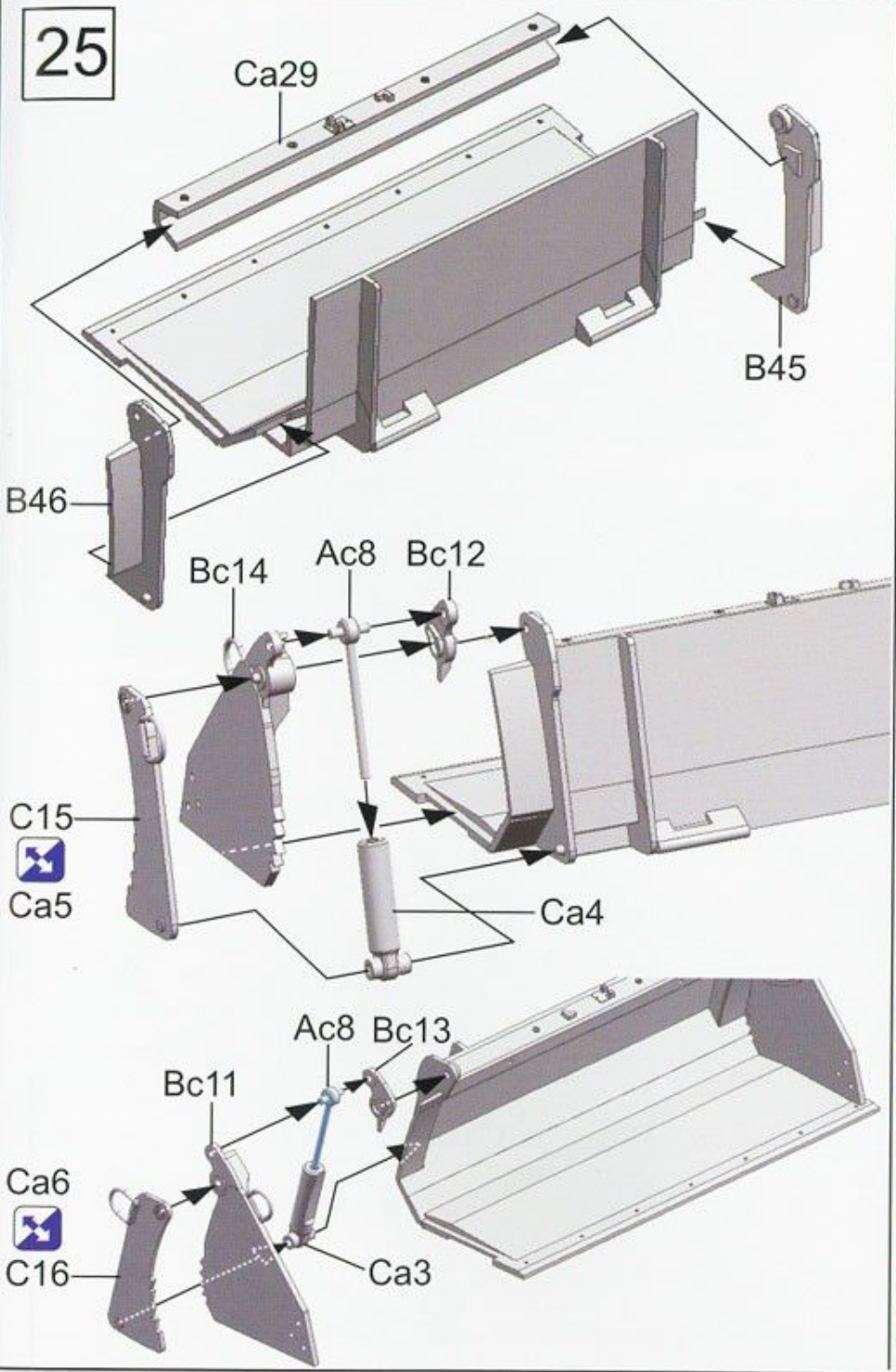

26

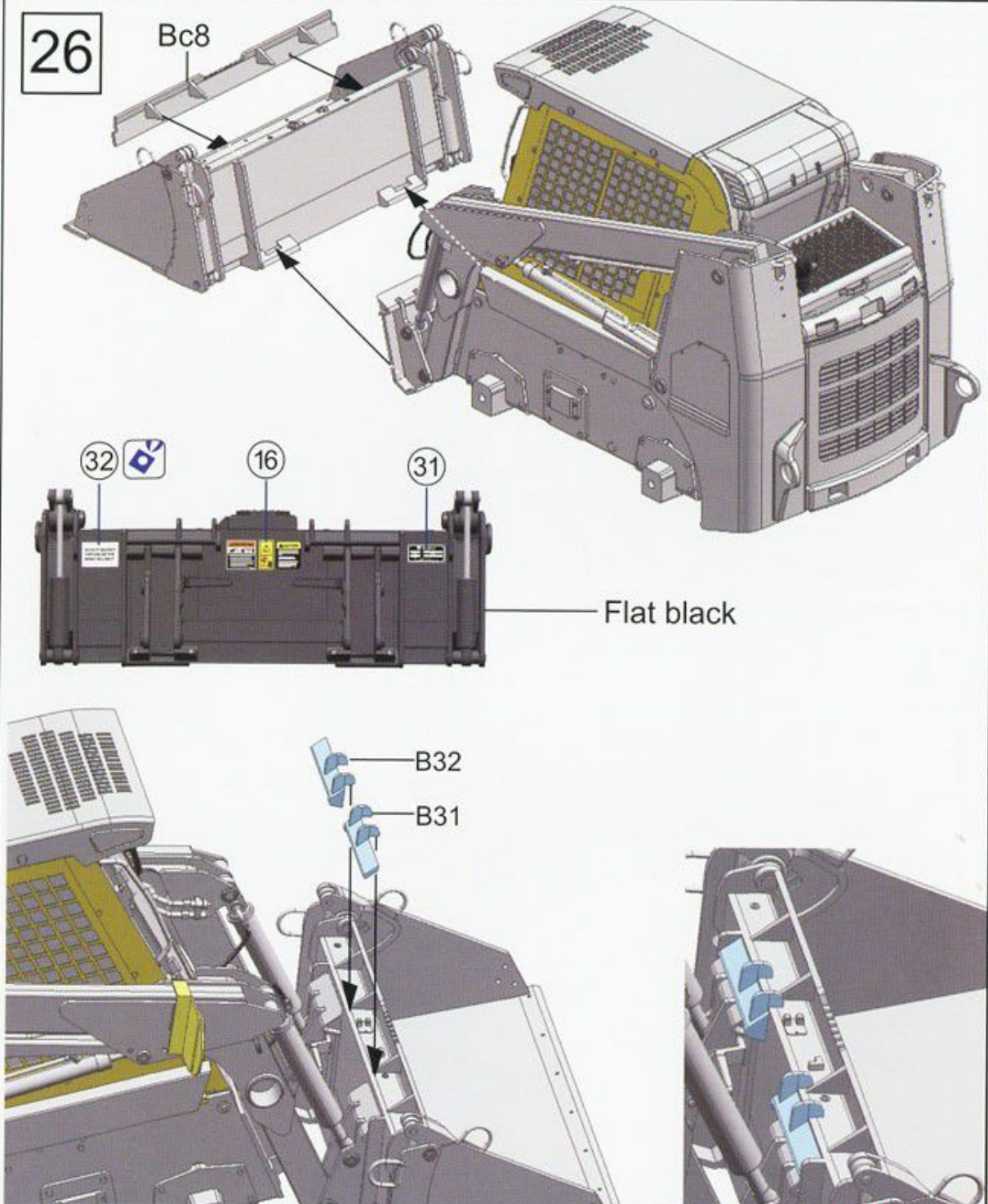

27

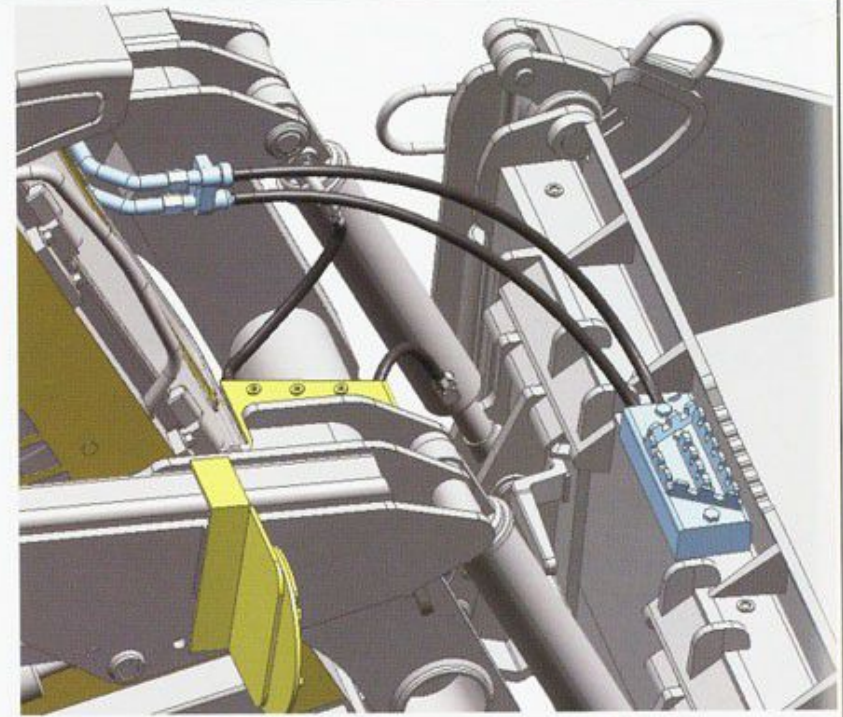
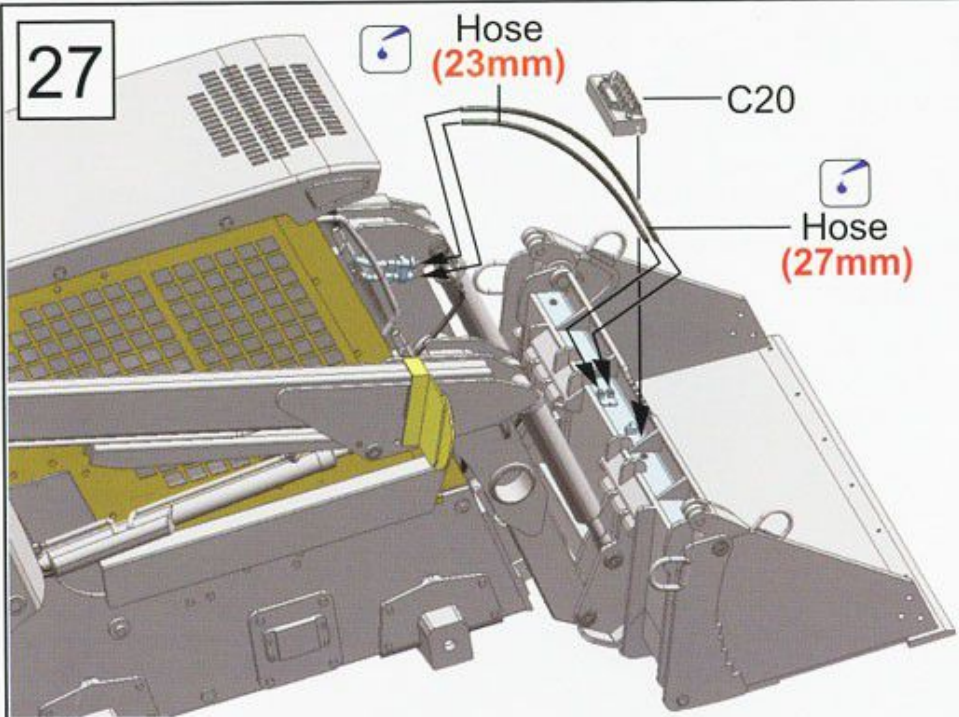

28

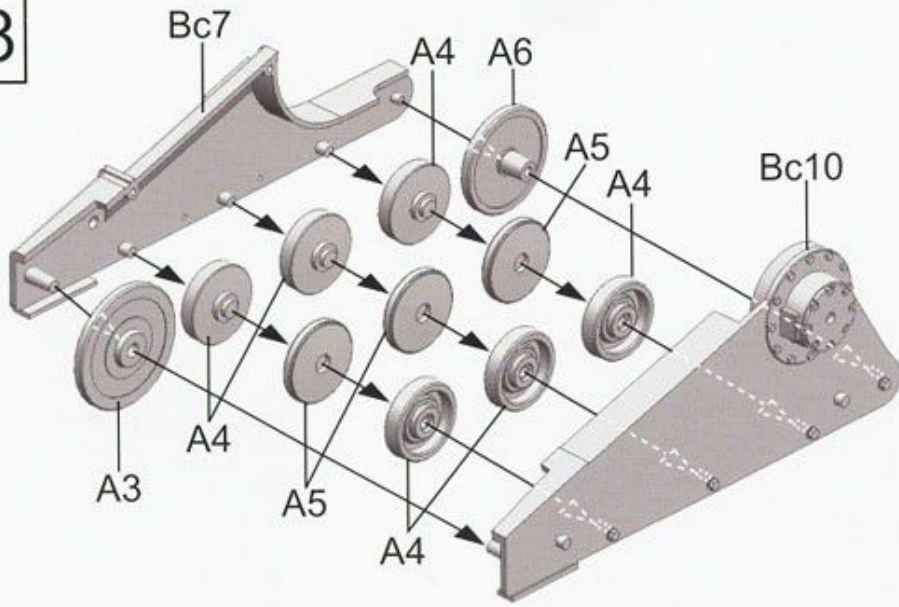

Right

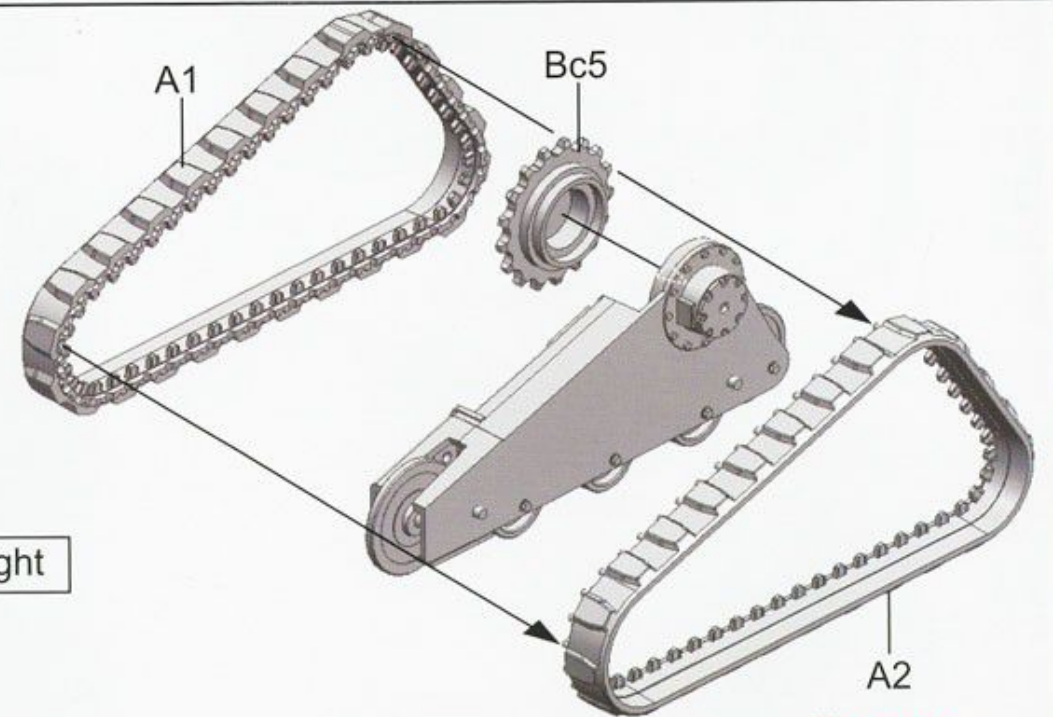



29

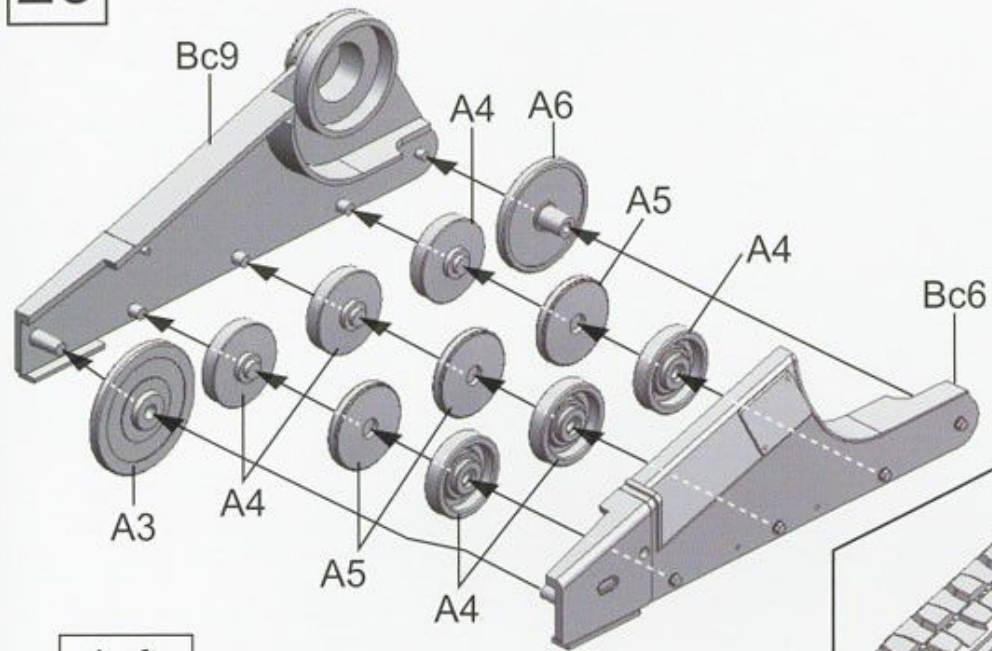

30

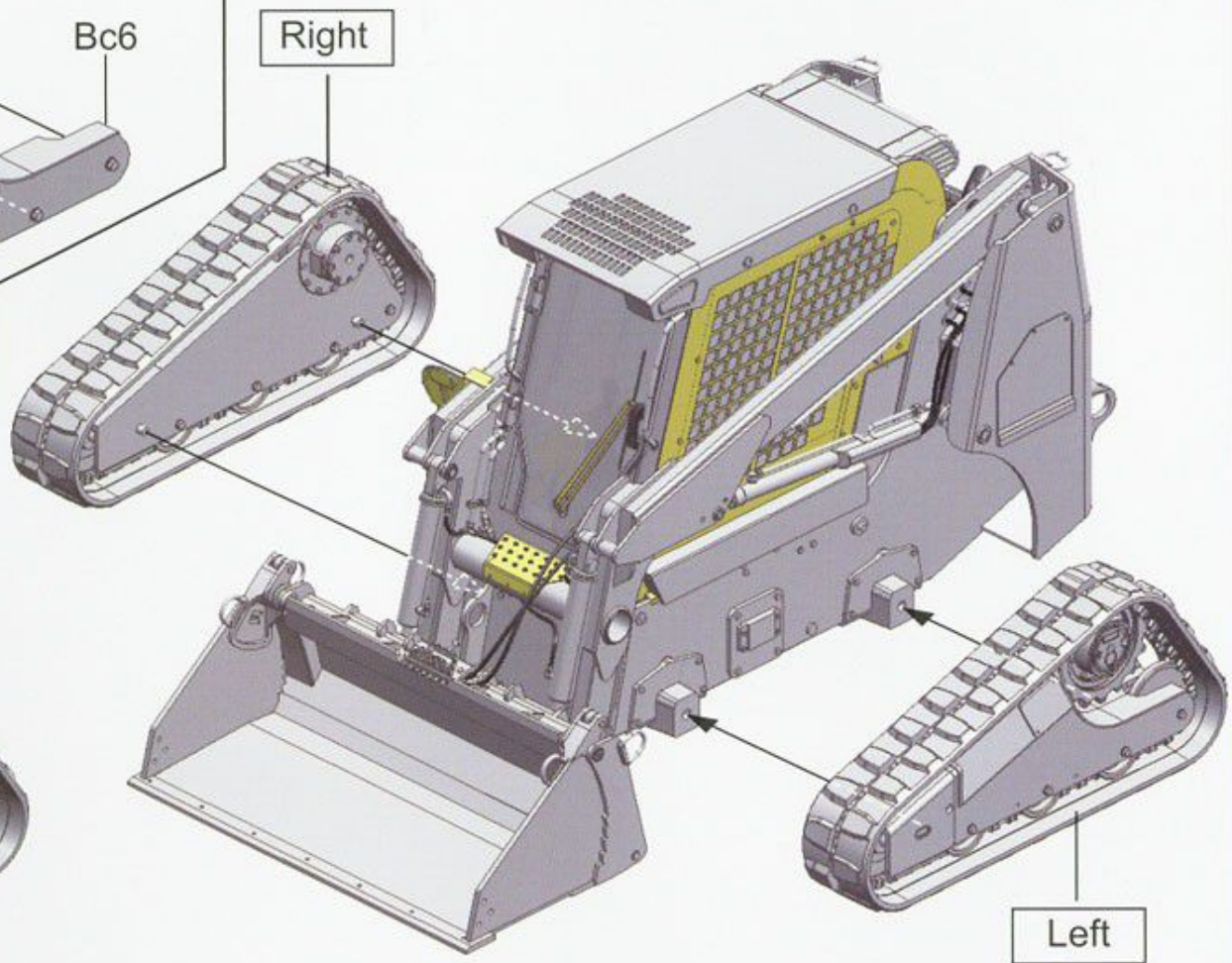
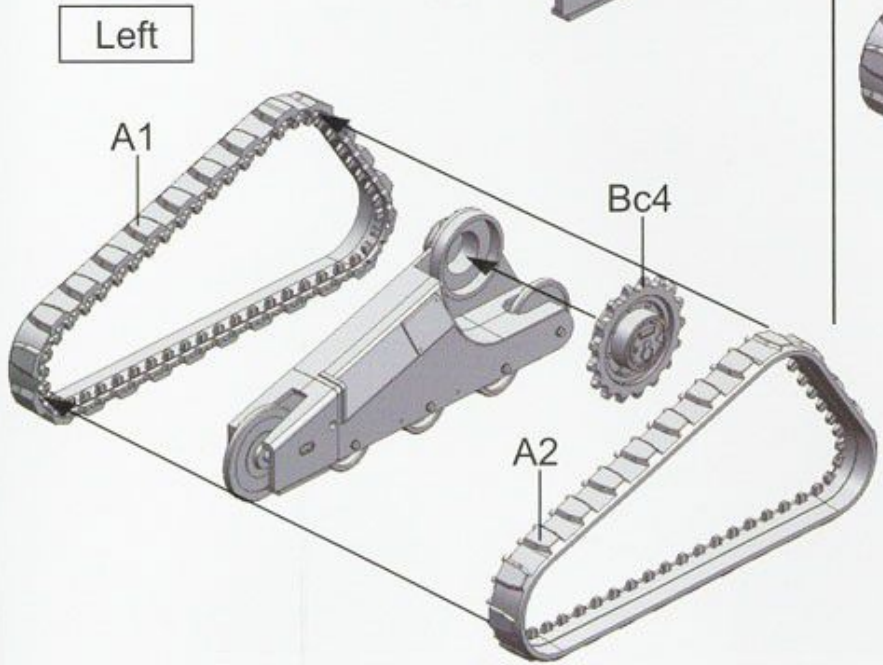

# Sprue Parts List

Ca x1

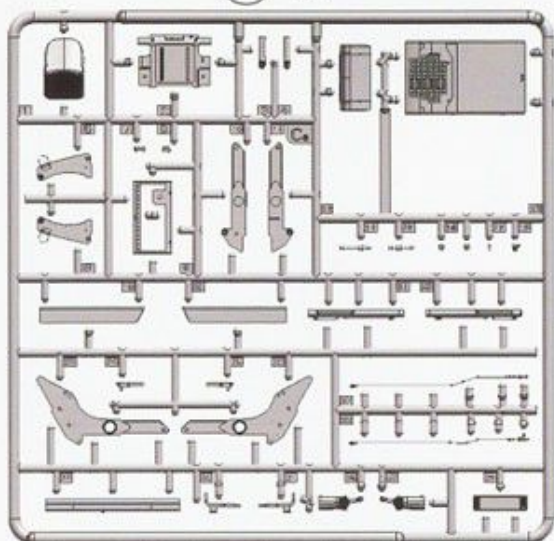

C x1

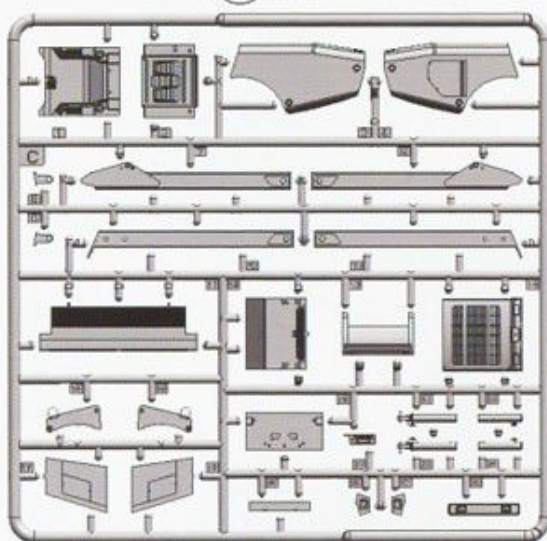

B x1

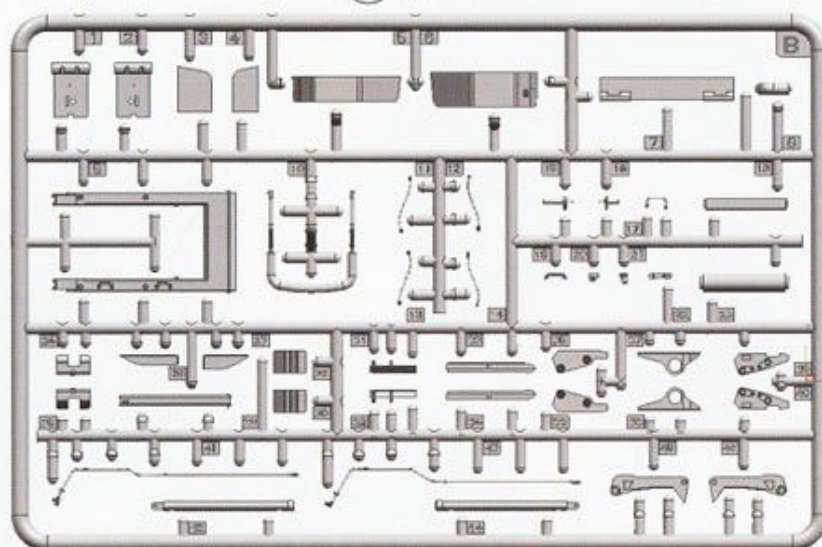

Bc x1

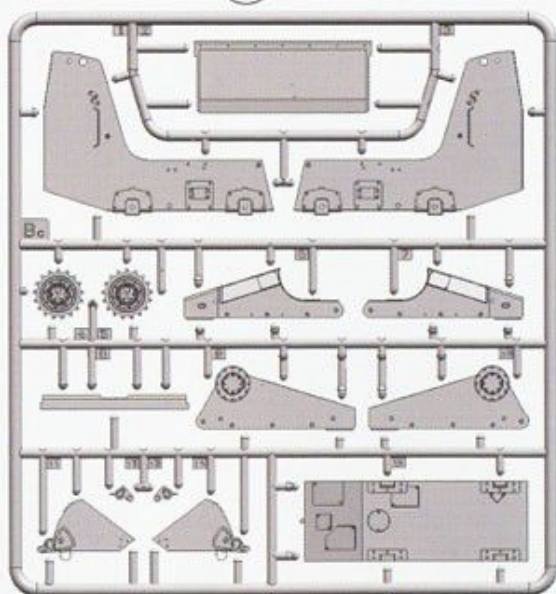

Ba x1



Ac x2

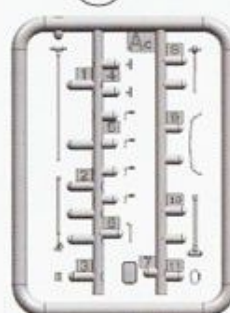

PE x 1

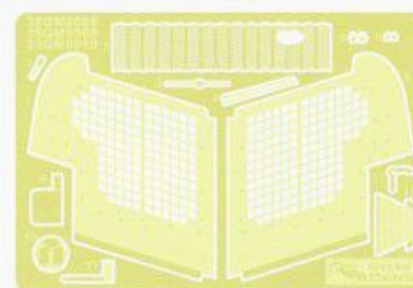

A x2

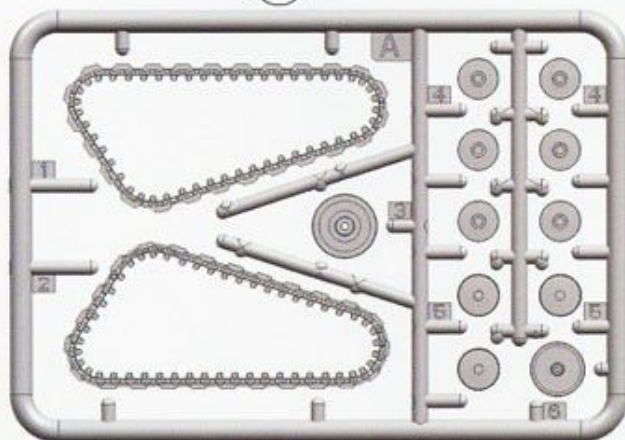

Decals x 1



Hose x 2



Decals x 1





**繁體中文** 自從JCB挖掘機被開發出來以後，民用工地建築上使用的設備尺寸不斷縮小，以提高機動性並能進入更小的作業空間。雖然最初主要設計用於民用，但小型滑移轉向和緊湊型履帶裝載機的概念也被證明對軍事用戶具有吸引力，M400T(履帶)及其輪式的M400W兄弟就是最好的例子。

美國軍方大概採購約1500台M400T。M400T已被使用作軍事化用途，可通過直升機、傘降式及運輸時使用航空級別的燃料，以確保其電氣系統經過遮罩以避免干擾，與其他軍用車輛的24v電氣系統相容並可連接。其他修改包括冷開機系統、為操作員的個人武器提供武器架以及使用防化學性塗料。每個M4000T配備一套螺栓連接設備，包括一個帶兩種尺寸配件的螺旋鑽、一個四合一多用途鏟鬥、託盤叉和一個液壓錘。

**簡體中文** 自从JCB挖掘机被开发出来以后，民用工地建筑上使用的设备尺寸不断缩小，以提高机动性并能进入更小的作业空间。虽然最初主要设计用于民用，但小型滑移转向和紧凑型履带装载机的概念也被证明对军事用户具有吸引力，M400T(履带)及其轮式的M400W兄弟就是最好的例子。

美国军方大概采购约1500台M400T。M400T已被使用作军事化用途，可通过直升机、伞降式及运输时使用航空级别的燃料，以确保其电气系统经过屏蔽以避免干扰，与其他军用车辆的24v电气系统兼容并可连接。其他修改包括冷启动系统、为操作员的个人武器提供武器架以及使用防化学性涂料。每个M4000T配备一套螺栓连接设备，包括一个带两种尺寸配件的螺旋钻、一个四合一多用途铲斗、托盘叉和一个液压锤。

## English

Since the development of the original JCB excavators, the size of equipment for use on civilian construction sites has continued to be reduced to improve manoeuvrability and to gain access to smaller spaces. Although initially designed primarily for civilian use, the concept of small skid steer and compact track loaders proved attractive to military users as well and the M400T and its wheeled M400w brother – in –arms are prime examples of this.

Approximately 1500 M400Ts have been procured. The M400T has been militarised to allow underslung transportation by helicopter, dropping by parachute and the use of military grade fuels, as well as ensuring that its electrical system is screened to avoid interference and is compatible with, and connectable to, the 24v electrical systems of other military vehicles. Other modifications include the inclusion of a cold start system, the provision of a weapons rack for the operator's personal weapon and the use of chemically resistant paint. Each M4000T comes with a set of bolt on equipment — including an auger with fittings for two sizes, a 4-in-1 multi-purpose bucket, pallet forks and a hydraulic hammer.

Story by Simon King

## Deutsch

Seit der Entwicklung der ursprünglichen JCB-Bagger wurde die Größe der Ausrüstung für den Einsatz auf zivilen Baustellen kontinuierlich reduziert, um die Manövrierfähigkeit zu verbessern und Zugang zu kleineren Räumen zu ermöglichen. Obwohl zunächst hauptsächlich für den zivilen Einsatz konzipiert, erwies sich das Konzept der kleinen Kompaktlader und kompakten Raupenlader auch für militärische Nutzer als attraktiv, und der M400T und sein Waffenbruder M400w auf Rädern sind Paradebeispiele dafür.

Etwa 1500 M400T wurden beschafft. Der M400T wurde militarisiert, um den Transport per Hubschrauber, den Fallschirmabwurf und die Verwendung von militärischen Treibstoffen zu ermöglichen und sicherzustellen, dass sein elektrisches System abgeschirmt ist, um Interferenzen zu vermeiden und mit den 24-V-Elektriksystemen anderer Militärfahrzeuge kompatibel und daran anschließbar ist. Weitere Änderungen umfassen die Aufnahme eines Kaltstartsystems, die Bereitstellung eines Waffenhalters für die Handwaffe des Bedieners und die Verwendung von chemisch beständiger Farbe. Jeder M400T wird mit einem Satz Ausrüstung geliefert – einschließlich eines Erdbohrers mit Anschlüssen für zwei Größen, einer 4-in-1-Mehrzweckschaufel, Palettengabeln und einem Hydraulikhammer.

Translation by Thomas Hartwig

## 日文





## 米陸軍 M400W 小型スキッドステア ローダー タイプ2

オリジナルのJCBショベルの開発以来、民間の建設現場で使用される機器のサイズは、機動性を向上させ、より小さなスペースへのアクセスするために縮小され続けています。当初は主に民間用に設計されていましたが、小型スキッドステアローダーとコンパクトトラックローダーのコンセプトは軍のユーザーにとっても魅力的であり、M400Tとその車輪付きM400w兄弟はその代表的な例です。

約1500台のM400Tが調達されています。M400Tは、ヘリコプターによる吊り下げ輸送、パラシュートによる落下、および軍用グレードの燃料の使用を可能にするために軍事化されています。また、電気システムは干渉を回避するためにスクリーニングされ、他の軍用車両の24v電気システムと互換性があり、接続可能な電気システムも備えています。その他の変更には、コールドスタートシステムの追加、オペレーターの個人用武器用の武器ラックの提供、耐薬品性塗料の使用が含まれます。M4000Tには、ボルトオン装置のセットが付属しています:4-in-1多目的バケット、パレットフォーク、油圧ハンマーの2つのサイズのフィッティングを備えたオーガー。

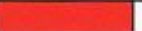
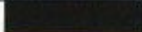
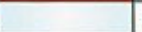
Option 2: US 2nd Platoon, 500th Engineer Company, 18th Military Police Brigade, During Exercise Saber Junction 16, Hohenfels, Germany, April 2016.

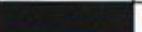
**MISSION MODELS**  
PREMIUM HOBBY PAINTS & PRODUCTS

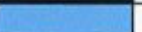
Gray		MMP-118	Clear red		MMP-167
Flat black		MMP-047	Silver		MMM-006
Desert sand yellow		MMP-070	Tire black		MMP-040
US ARMY OD		MMP-026	Clear blue		MMP-168

