

Panzerkampfwagen IV Ausf.H

1/35 MILITARY MINIATURE SERIES

KIT NO.MM-154A



TAMIYA

MODEL RECTIFIER CORPORATION
EDISON, NEW JERSEY 08817



Story by Chris Ellis

In Spring, 1935, Krupp, Rheinmetall and MAN all submitted designs to fit the specifications for a 'support' tank drawn up by the Heereswaffenamt. This vehicle, in the 20 ton Class, was the VK 2001, known under the code designation of BW (Battillonsfuhrerwagen), and the Krupp design was chosen for production. The prototype trials took place at Ulm and Kummersdorf in 1937.

As with the smaller Pz Kpfw III, some pre-production models were built in small numbers for "troop trials". Three models, Ausf A, B, and C had been built by 1939 and the few available vehicles took part in the Polish Campaign. There was much less variety in detail of these, and the relative unimportance of the Pz Kpfw IV as originally conceived and ordered is that only one contractor was involved as against eight for the Pz Kpfw III. Also, in the Blitzkrieg era of 1939-41, there was little change in the Pz Kpfw IV for it was in service, fulfilling the role General Guderian, while Chief of Staff to the Inspector-General of Motorized Troops, had envisaged for it. In the event, however, the Pz Kpfw IV was destined to supplant the Pz Kpfw III as the mainstay of the Panzer Divisions for its larger size allowed it to be more effectively up-gunned and up-armoured when the urgent need arose for a more effective answer to the new Soviet and American tanks of 1942-43. The Pz Kpfw IV, indeed, had the distinction of remaining in production throughout the war, both as a

battle tank and as a major basis (with all the other standard types) for the dozens of self-propelled guns and tank destroyers which the Germans produced.

With the outbreak of war in 1939, the design was "frozen", and large scale production was ordered as the Pz Kpfw IV Ausf D. Against the Pz Kpfw III, the Kpfw IV's production was modest, as will be evident from the following numbers of Pz Kpfw IV on Army strength during the first three years of the war:

End of 1939 — 174. End of 1940 — 386.
End of 1941 — 769.

In fact, the total Pz Kpfw IV production during 1941 amounted to only 480, despite an order in July, 1941 which requested production of 2,160 to equip the planned expansion to 36 armoured divisions. A monthly production goal of 40 per month was set for 1941. In January, 1942 a monthly output of 57 units was anticipated. In the event this target was exceeded, and 964

PzKpfw III

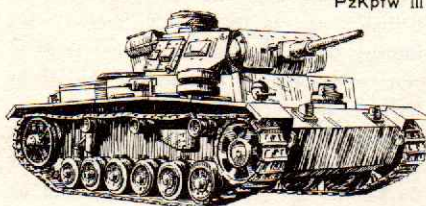

urgently-needed vehicles were produced in 1942. Originally the main assembly was by Krupp-

Gruson, with hulls and turrets supplied by Krupp of Essen and Eisen of Bochum. This picture changed considerably during 1942, due to Allied air raids. The relocation of key war industry to areas not readily accessible to the Allied bombers was begun in 1940 and established several new tank factories. One of these was the Nibelungenwerk at St. Valentin, Austria, managed by Steyr-Daimler-Puch. Initially in-

Char B I

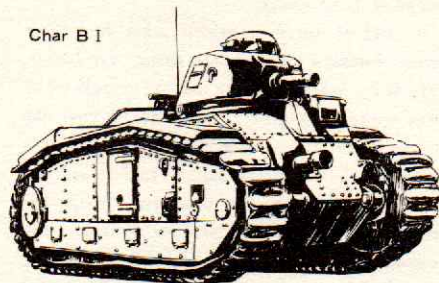

tended for the production of a replacement vehicle for Pz Kpfw IV—the Porsche "Leopard"—this factory was completed just in time to take on the expanded Pz Kpfw IV production instead. From 1943, the Panzer IV was assembled almost exclusively at this factory, and remained in production there until the end of the war. Its proximity to the Hermann Goering Steel Mills at Linz provided a source of material for hulls and turrets. The raw material used in one Pz Kpfw IV (without weapons, optical instruments or radio equipment was: —

Steel.....39,000 kg Tin1.20 kg
 Copper195.10 kg Aluminium ... 238 kg
 Lead 63.30 kg Zinc66.40 kg
 Magnesium..... 0.15 kg Rubber.....116.30 kg

These totals illustrate the strain on the blockaded and stretched German industry of tank production, and go far to explain its limitation, even in the early days of the war, and by comparison with the achievements of Allied industry in this field.

The Panzer IV hull was a comparatively simple design. All joints were austenitic steel welds, and the plates were high-quality chromium-molybdenum steel made by the electric furnace process. Two bulkheads separated the hull into three compartments—driving, fighting and engine. The front driving compartment housed the transmission and final drive assemblies, in addition to seats for both driver and radio operator/hull gunner. Three petrol (gasoline) tanks with a capacity of approximately 105 gallons were located beneath the floor of the centre fighting compartment. A most noticeable and characteristic feature of the vehicle was the superstructure, of welded construction, bolted to the top flange of the hull. To accommodate the rather large turret race, it projected well beyond each side wall of the hull. One bolted and two hinged maintenance hatches were provided in the front glacis plate; access hatches for driver and radio operator were provided in the roof plate,

KV-II

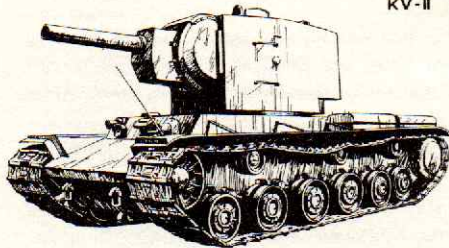

though there were many detail changes incorporated in later models.

The welded turret provided seats for three crew members—commander, gunner and loader. The slides were sloped, so that the overall width was appreciably greater than the internal diameter of the turret ring. The 7.5 cm gun was mounted on a trunnion axis. The forward end of the recoil mechanism projected through the mantlet to afford additional protection. The commander's cupola, set well back on the turret roof, had five observation ports equally spaced around it, with the front port pointing directly forward in line with the gun. It was closed by a pair of semi-circular hatch covers. An observation port was provided in each wall of the turret, in front of the side access hatches. A signal port was fitted on the turret roof, similar to the ones mounted on both driving compartment crew access hatches. There were also two revolver and carbine ports at the rear of the turret. The fighting compartment was ventilated by a roof-mounted extractor fan. The main power plant was the standard medium

tank engine, the Maybach HL 120 TRM, a 12-cylinder, 11.86 litre liquid-cooled petrol engine. Normally developing an output of 300 b.h.p. at 3,000 r.p.m., the engine was in most instances restricted to 2,600 r.p.m., giving a rating of 265 b.h.p. It used only 74 octane petrol. Cooling air entering through louvres on the left hand side of the engine compartment, was drawn through two radiators and over the engine by two ten-bladed fans.

The Pz Kpfw IV, being a bigger vehicle, took over the role originally foreseen for the Pz Kpfw III as the principal battle tank, and was truthfully described as the "workhorse of the Panzer Divisions". Though inferior in shape

T34/76

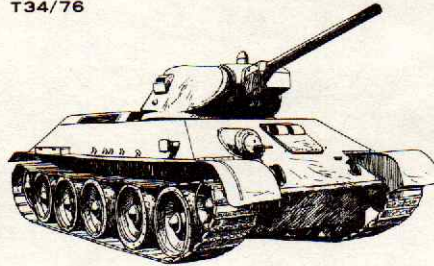

and equipment to the T-34 and the post-1942 German designs, the Pz Kpfw IV had virtues like the Allied Sherman Tank—it was reliable and relatively simple to maintain.

The Pz Kpfw IV Ausf E was a major production type with a simplified one-piece front to the superstructure, and retaining the 7.5 cm gun. The Ausf F (later re-designated Ausf F1) was an up-armoured model basic armour of 50 mm at the front and a ball-mounted hull machine gun. Like the Pz Kpfw III it had a simplified idler wheel and widened tracks.

The major development, however, was the Pz

PzKpfw IV Ausf F1



Kpfw IV Ausf F2, the original F re-armed with a long high velocity 75 mm gun, and produced specifically to restore the balance of fire-power to the Afrika Korps in 1942 when the American-built tanks with 75 mm guns were entering service with the British. This vehicle was exceptional, and most effective—known to the British troops as the "Mk IV Special"—but Rommel could never get enough of them to restore the Panzer Divisions of the Afrika Korps to their original dominating position on the battlefield. The Pz Kpfw Ausf G was a similar vehicle, but built from the start with the high velocity gun, and with an improved, up-armoured turret, and detail changes.

By mid-1943 the vehicle was further refined with the appearance of the Pz Kpfw IV Ausf

H. It was similar to the G model but had a yet more powerful 75 mm gun, the L/48, which was about 15 inches longer than the L/43. It had also a new cupola with 100 mm armour thickness, and some vehicles had 30 mm plates of extra armour welded or bolted on the nose. Later vehicles were built new with 85 mm thick frontal armour. Simplified suspension components were used to reduce production costs. For protection from hollow-charge anti-tank projectiles of the "bazooka" type, mild steel skirt armour plates were suspended from rails attached to the superstructure, for bazooka-type weapons were now in Allied service on an increasing scale. Zimmerit anti-magnetic compound also made its appearance at this time to stop the placement of magnetic charges on the vehicle.

Last of the Pz Kpfw IV line was the Ausf J, with further changes to simplify production: the generator which provided power traverse for the turret was removed and replaced by extra fuel tanks. Heavy gauge mesh wire replaced the steel skirt armour, and most late vehicles had spaced armour plates right round the turret. Appearing in mid 1944, the Ausf J remained in production until the end of the war.

The new gun KwK 40, of Panzer IV Aus F2 was easily distinguishable by its increased barrel length and muzzle brake. While the first production model was fitted with a single-baffle globular muzzle brake, later vehicles had a double brake. The gun itself was capable of penetrating homogenous armour of 77 mm thickness at 2,000 yards using PzCr 39 at normal impact. It could fire at least six different kinds of ammunition: Panzergranate 40 (A.P.C.R.), PzGr 39 (A.P.C.B.C.), Sprenggranate 38A and B (H.E.A.T.), Sprenggranate 34 (H.E.) and Nebelgranate (Smoke shell). A total of 87 rounds was carried, plus 2,250 rounds of 7.92 mm ammunition for both MG 34 machine-guns, one of which was mounted co-axially on the right side of the gun. The second machine gun was mounted on the right side of the front vertical plate and operated by the radio operator. It had a ball mounting with a hemispherical fixed external mantlet, the ball being inserted from the outside. Turret traverse was effect both by hand and electric power gears supplied from a generator, driven by a DKW two-cylinder 10 h.p. 500 cc petrol engine.

DATA:

Length:	5.89 m.
Width:	3.29 m.
Height:	2.68 m.
Weight:	85 tons
Armour (maximum):	80 mm.
Crew:	5
Speed:	42 km/hr
Armament:	1 7.5 cm KwK 40 L/48 and two MG 34
Engine:	Maybach HL 120 TRM, V-type 12 cylinder, 300 h.p.



Please read this before commencing assembly

★Be sure to read the following instructions carefully before starting assembly work.

★You will need a sharp knife, a screwdriver, a pair of tweezers, a file, and a pair of pliers.

★Do not break parts away from sprue, but cut off carefully with a pair of pliers.

★Use glue sparingly. Use only enough to make a good bond. Apply cement to both parts to be joined.

★Pztkpfw IV tanks were used in large quantities on the battlefield. Pztkpfw IV tanks even in the same Ausf H category varied in accessories and some of them had no armour plates. To meet the need, the kit contains Accessory Parts. Before fixing and painting the Accessory parts, be sure to read the following through and decide what sort of Ausf H tank to make.

★The model tank should be painted after being completely assembled.

1 Construction of Rear Panel

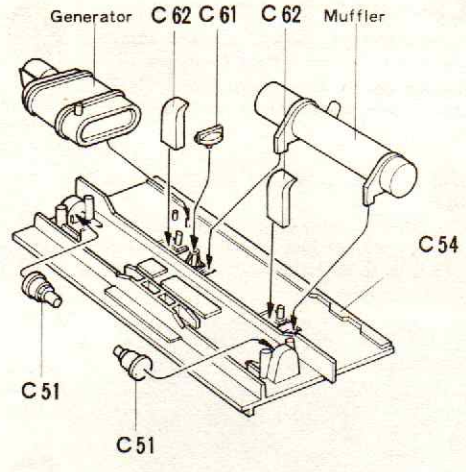
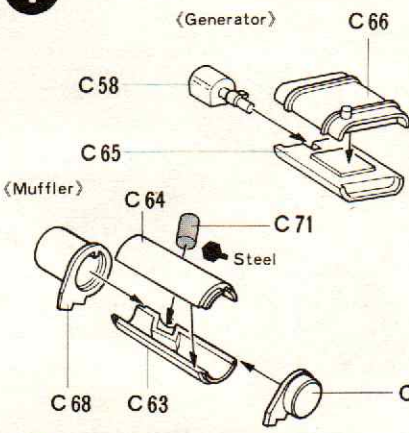

2 Fixing of Suspension Parts

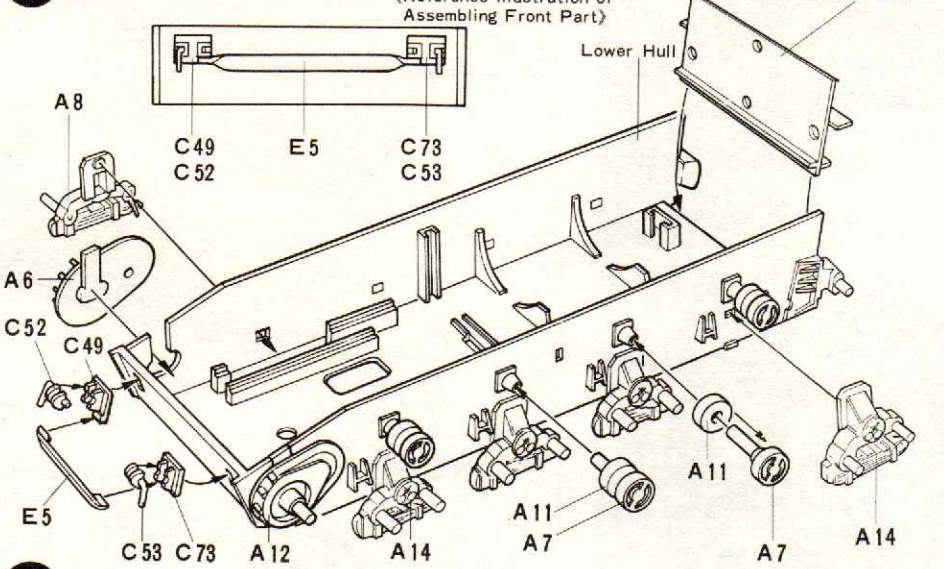

3 Construction and Fixing of Upper Hull

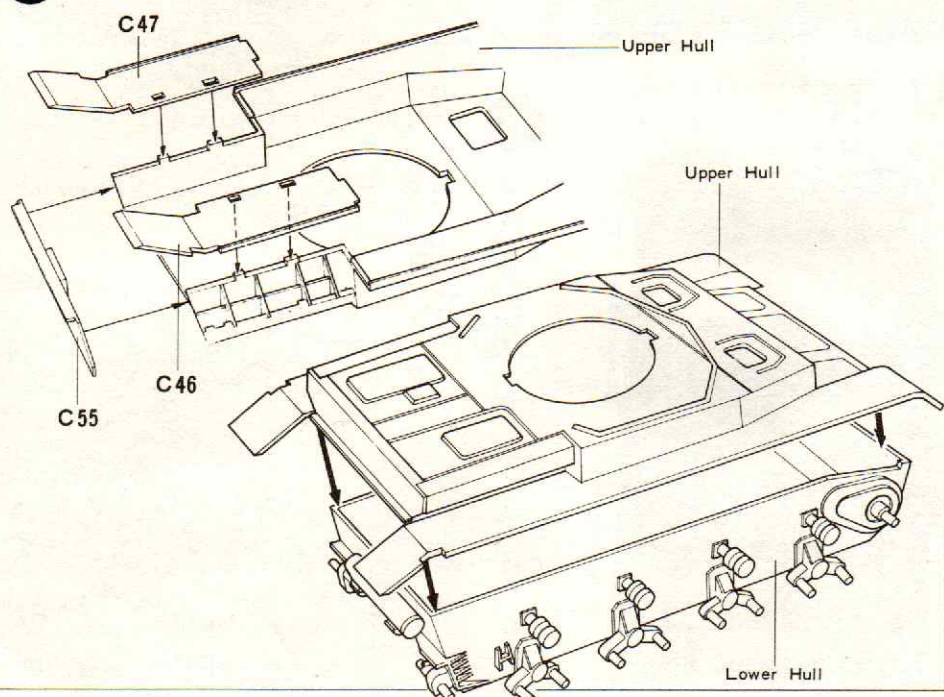

1 (Construction of Rear Panel)

Fix Parts to the Rear Panel as shown in the figure.

2 (Fixing of Suspension Parts)

Fit the Rear Panel constructed at 1 to Lower Hull. Firmly cement Suspension parts to Lower Hull.

3 (Construction and Fixing of Upper Hull)

Fix Fenders, right C47 and left C48, to Upper Hull.

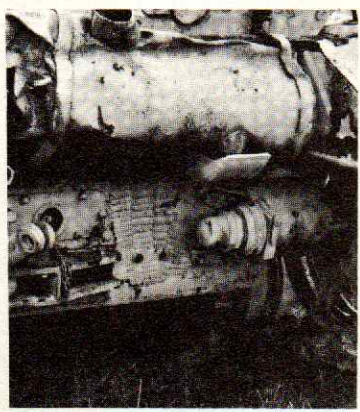

★The photograph above shows a Pztkpfw IV tank kept in the Aberdeen Tank Museum. It is considerably damaged in its fenders, etc.

4 (Construction of Wheels)

Construct each wheel. Do not apply too much cement. Poly Caps are designed to be fixed onto Lower Hull shafts and make wheels revolve.

5 (Fixing of Wheels and Rear Parts)

Fix Wheels constructed at 4. Do not use cement but just insert. Make sure of parts to be cemented, when you fix Parts to Rear Panel.

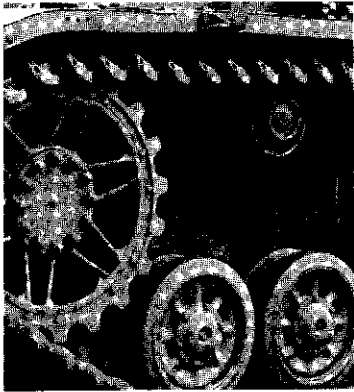

6 (Fixing of Upper Hull Parts, A)

Fix various parts making sure that you do not apply too much cement.

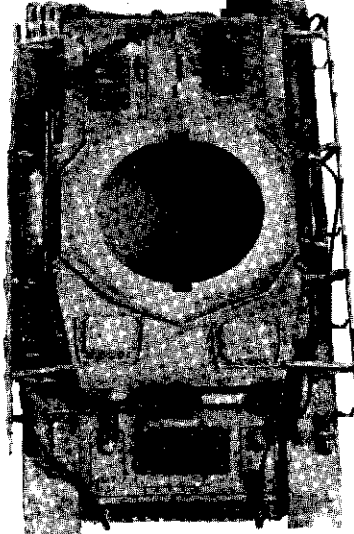

4 Construction of Wheels

(Drive Sprocket)
Make 2 sets.

(Rear Wheel)
Make 2 sets.

(Road Wheel)
Make 16 sets.

(Spare Wheel)
Make 2 sets.

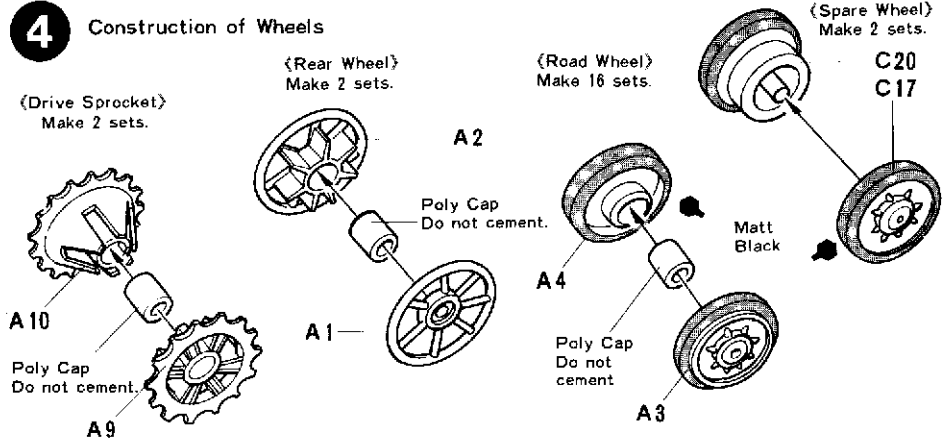

5 Fixing of Wheels and Rear Parts

(Fixing of Rear Parts)

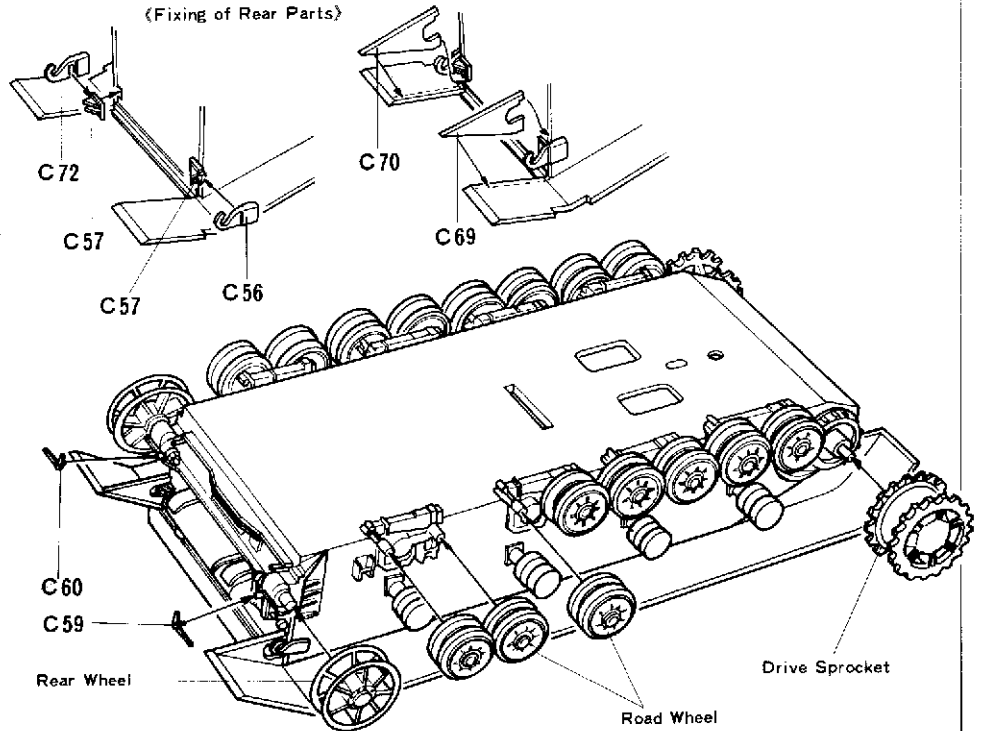

6 Fixing of Upper Hull Parts, A

★Do not cement but just insert each wheel.

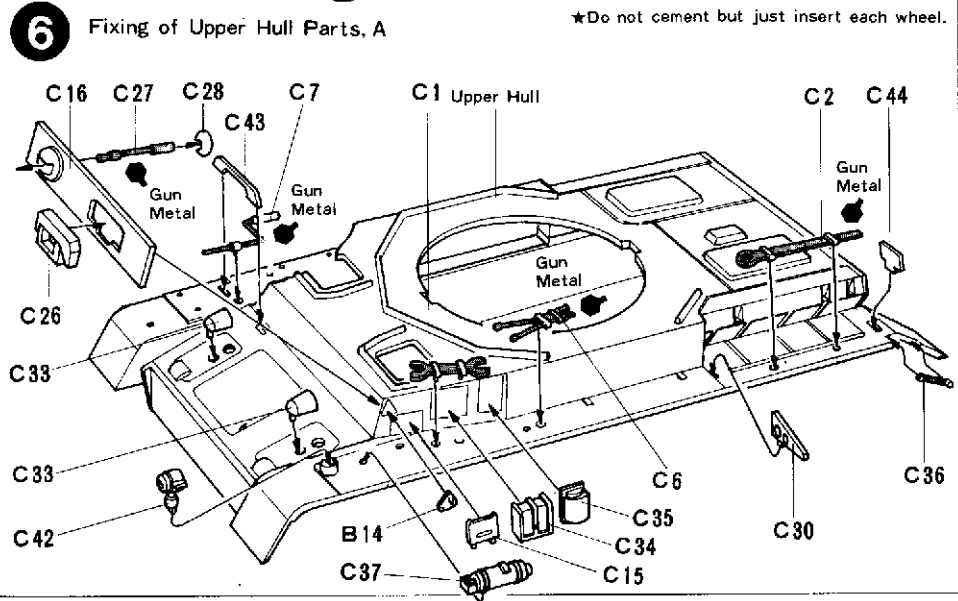

7 (Fixing of Upper Hull Parts, B)

If you are fixing Armour Plates, fix parts C8 and C9 at step 10. Construct Spare Wheel Holder and Hook before you fix them to Upper Hull.

(How to make antenna)

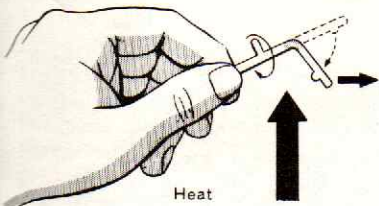

★Heat: one of runner gradually while turning around. When the center portion began to melt, stop heating and stretch both ends of the runner slowly to opposite way to the thinness wanted. Hold it in that position for about 15 seconds to cool, and cut it to proper length.

★Caution: Be careful in handling fire.

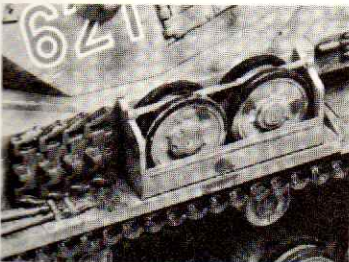

8 (Fixing of Upper Hull Parts, C)

Construct Muffler and Jack beforehand and cement them to the Upper Hull.

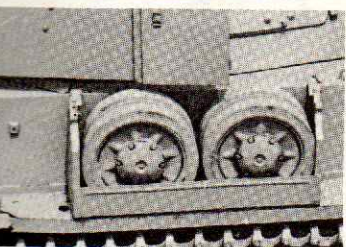
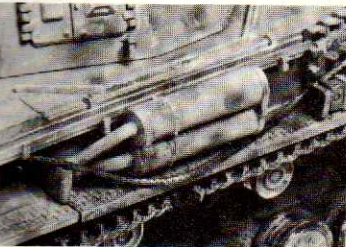

9 (Construction of Gun Barrel)

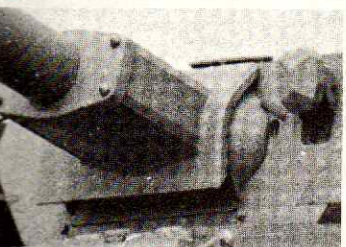

7 Fixing of Upper Hull Parts, B

★When you fix Armour Plates, do not fix C8 and C9 here.

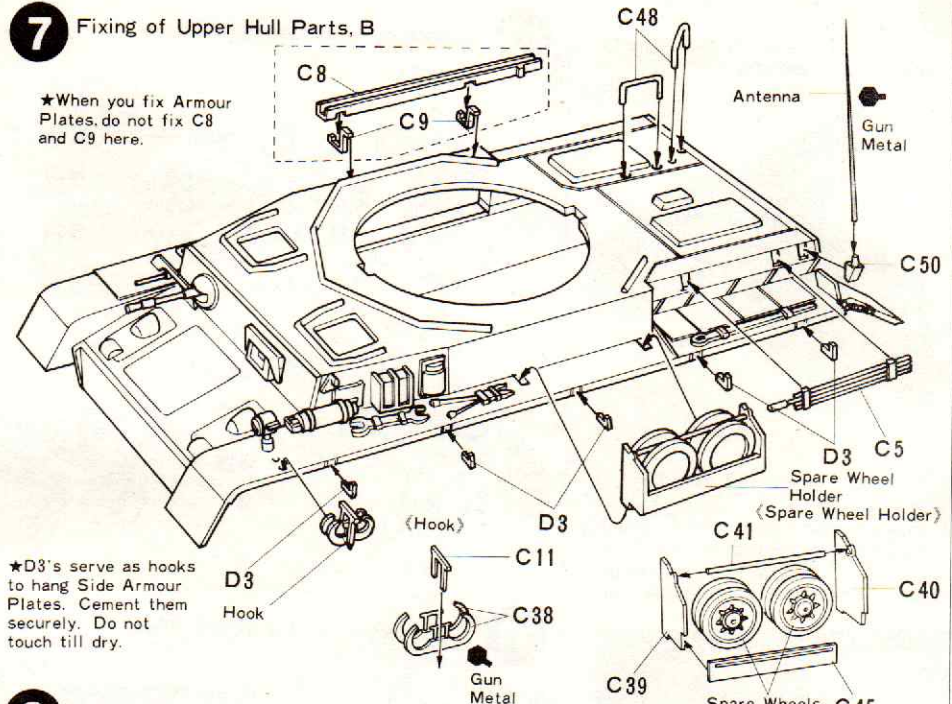

★D3's serve as hooks to hang Side Armour Plates. Cement them securely. Do not touch till dry.

8 Fixing of Upper Hull Parts, C

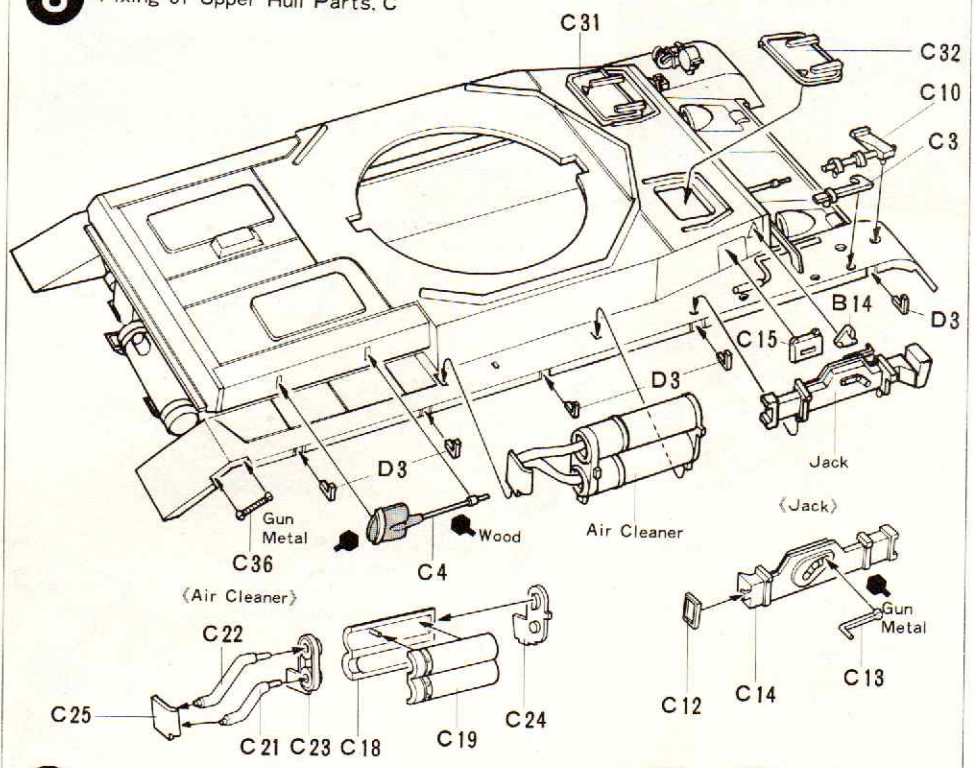

9 Construction of Gun Barrel

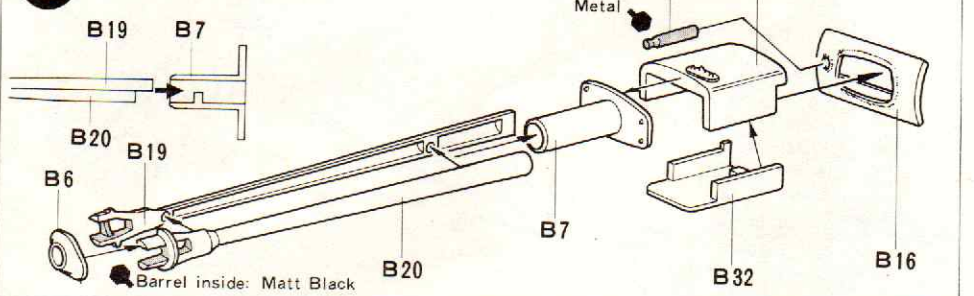

10 (Construction of Loading Section)
There are a number of fragile parts. Cement them carefully.

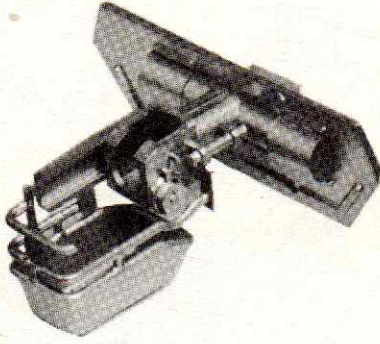

11 (Construction of Turret Top Plate)
Cupola parts have joint guides. Check them before cementing the parts together. A Figure is to be put in the Cupola and its Hatch should be kept open.

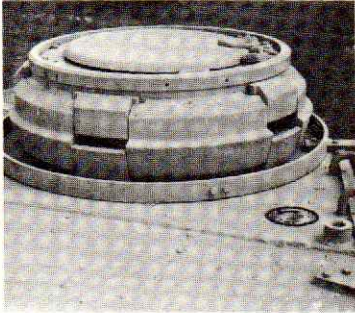

(Construction of Figures)



10 Construction of Loading Section

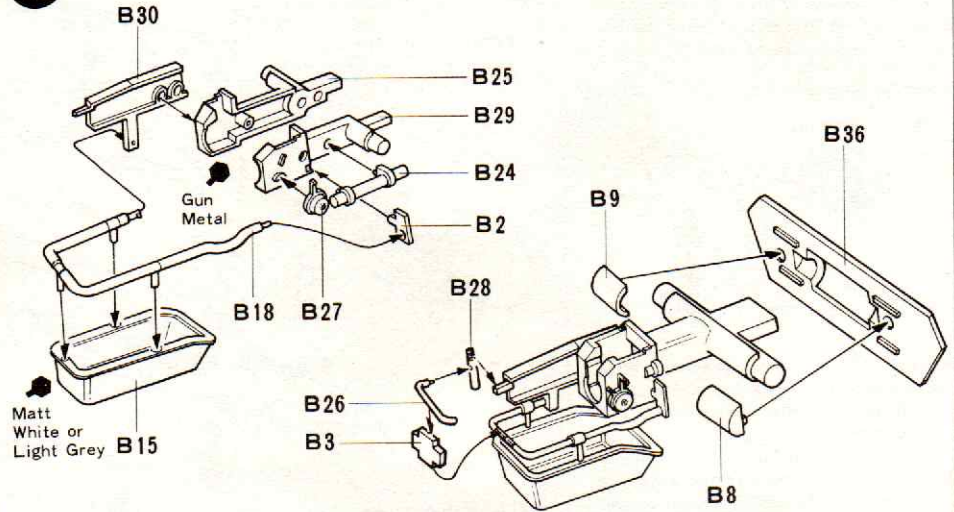

11 Construction of Turret Top Plate

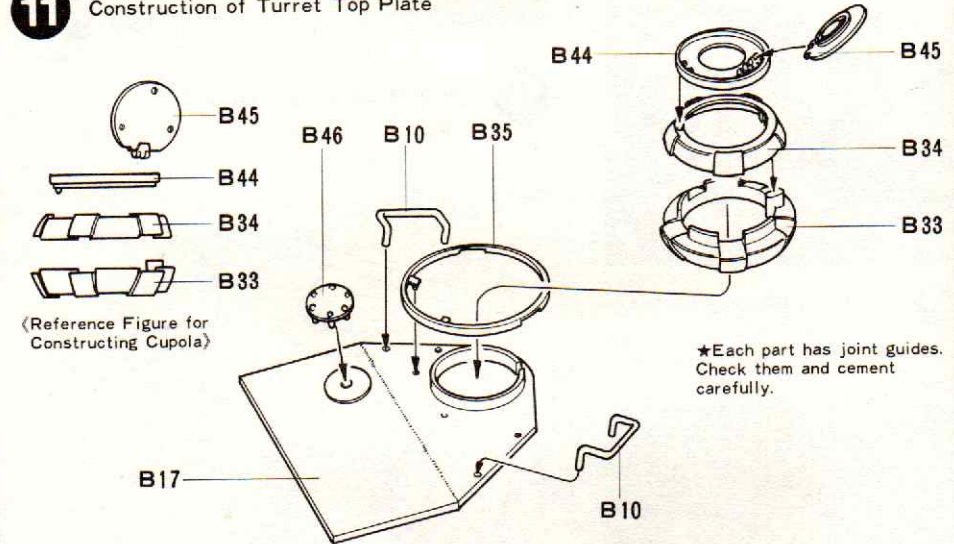

12 Construction of Turret, A

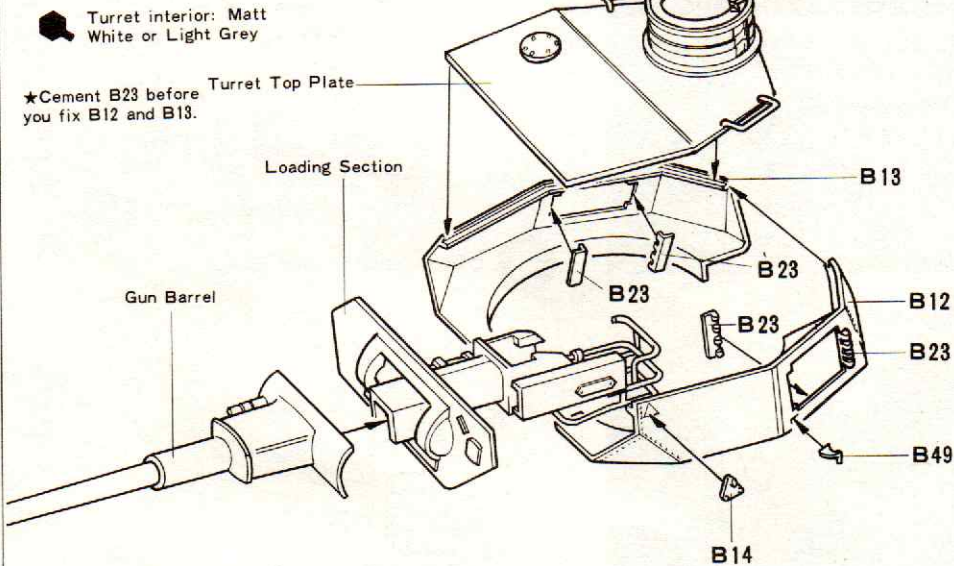

13 Construction of Turret, B

Tool Box B37 should be fixed to Turret after being fitted with B4, B21 and B22.

14 Fixing of Turret

Fit Turret sideways to Hull as shown in the figure and then turn it in the direction of the arrow.

(Good Way to Connect Tracks by Heating)

① Cut off unnecessary part from the tracks and put pins on one end through holes on the other.

Cut off this part.

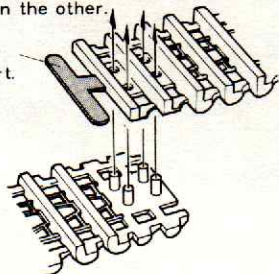

② Press the pins carefully by means of an old screwdriver or nail head with wood handle which has been heated with a heating device such as a candle fire.

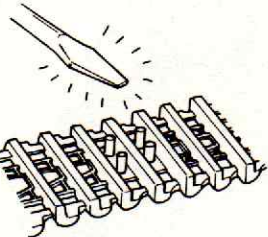

③ Immediately after that, hold pins with your fingers for a while. The pressed pin heads should be round in shape.

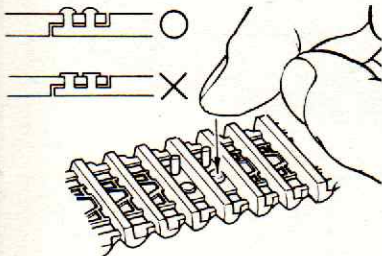

④ If the track is broken or its connection is too weak, reinforce it with black thread or staples as shown in the figure.

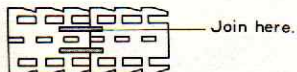

15 Construction of Accessory Parts

Figures from 16 onward show the construction and fixing of the Accessory Parts. See the photograph of a completed model printed on the next page.

13 Construction of Turret, B

(Tool Box Assembly)

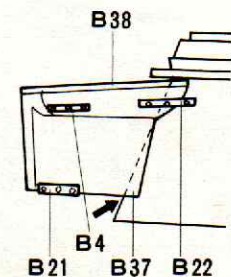

★Cement B4, B21, B22 to Tool Box B37 as shown in the figure.

★Fix Tool Box to Turret by applying cement to B22 and arrowed position.

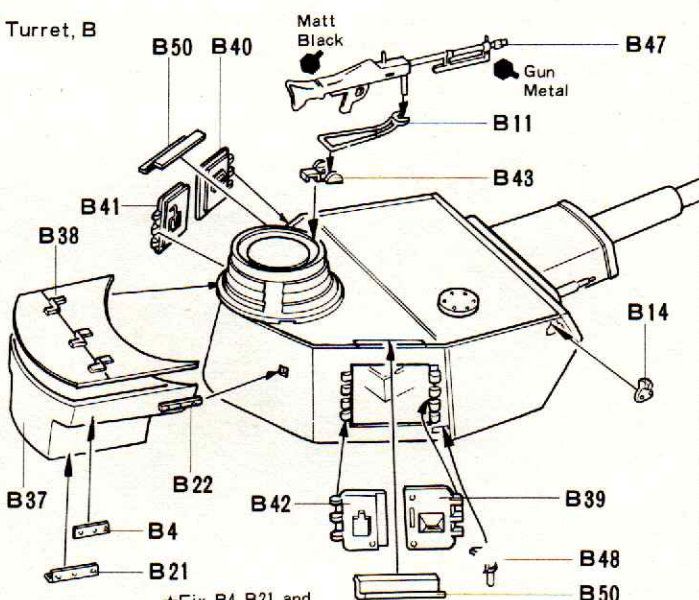

★Fix B4, B21, and B22 also to left side.

14 Fixing of Turret

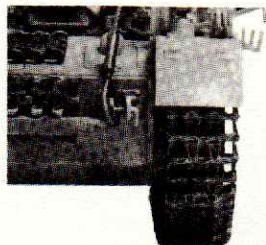

Turret: Fit this to Hull in the position as shown in the figure and turn to the direction of an arrow.

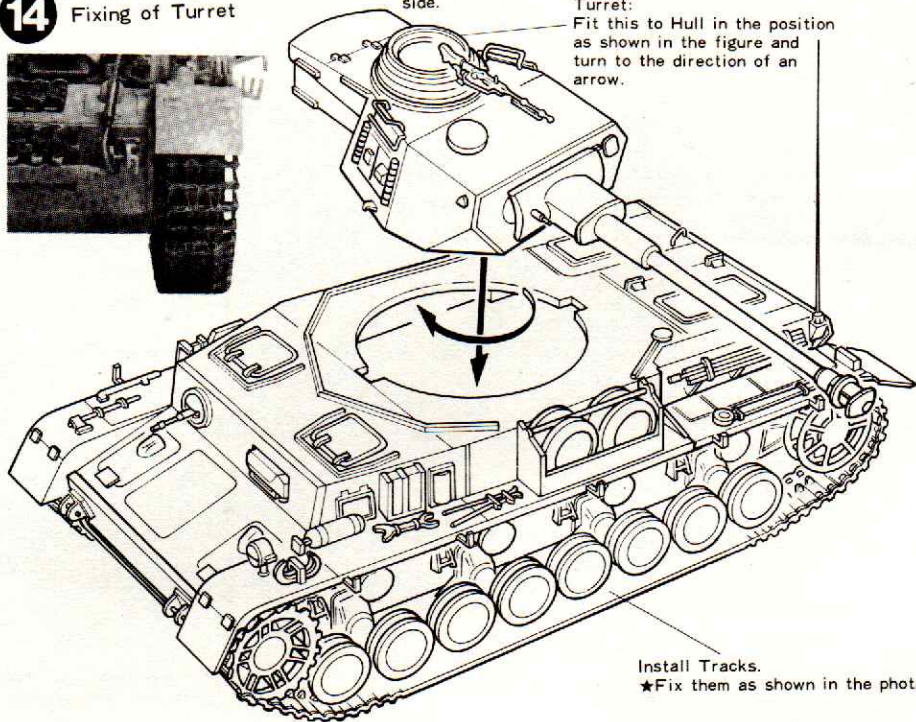

Install Tracks.
★Fix them as shown in the photo.

15 Construction of Accessory Parts

(Spare Wheels)

(Jerrycans)

(Spare Track Links)

(Bucket)

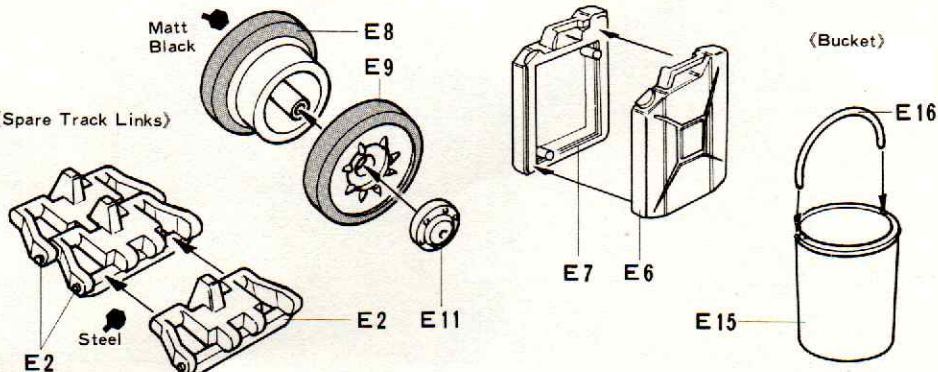

< Fixing of Accessories >

Tanks carried various accessories according to the terrain and conditions of the battlefield. They often underwent temporary repair of damage caused by severe fighting and got accessories from other tanks. They usually carried auxiliary equipment necessary for the action in every possible place on the vehicle.

< Mounting of Spare Track Links >

Tanks carried some spare track links to provide against damage to their own ones in use. Pzkw IV tanks, in particular, often carried them also as a means of protection against bombs and shells. To cite a typical example, some tanks of this type mounted spare tracks on the lower sides of the hull which were said to be vulnerable to attack.

< Mounting of Wire Ropes >

The Accessory Parts contain two different ropes. The 8-shaped thin rope was often fixed to the rear of the hull. The straight thick rope was usually fixed at one end to a front hook, etc. and stretched to the rear of the hull.

< Bending of Wire Ropes >

Slowly bend the wire ropes by heating them with a soldering iron, hot water, etc. until they form a desired curve. Actual ropes were made of steel wire and did not have a sharp curve. Give your model ropes a natural curve so that they may look as if they curved under their own weight. Keep in mind that to use candle fire or the like which produce flame is to invite failure.

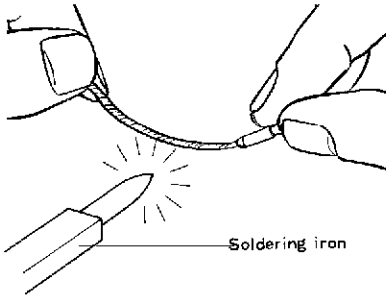

< Fixing Wire Rope to Front Hook >

Cut a round end of the rope with a sharp knife as shown in the figure and make the end a little wider. Then, fit it in the hook.

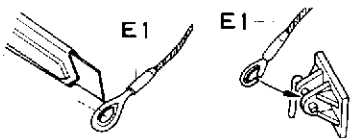

< 8-shaped Rope and Spare Wheels >
Cement parts E12 and E13 to Hull as shown in the figure below.

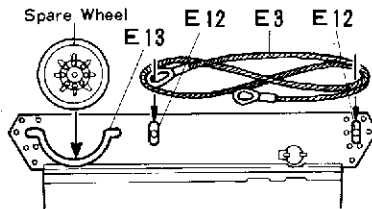

Fixing of Accessories

< Standard Type >

★Fixing of Armour Plates is illustrated from page 10.

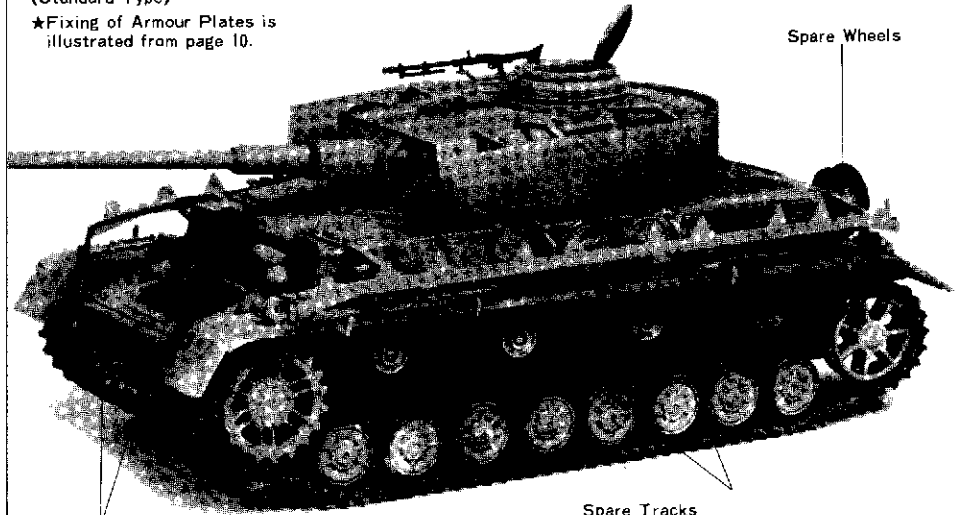

Spare Tracks
Most of Pzkw IV carried some spare track links on the front. Some of these tanks had even double piled tracks.

Spare Tracks
This shows spare tracks attached to the lower hull of the tank. Reproduce this on your model tank by cementing each set of track links which consists of two or three pieces.

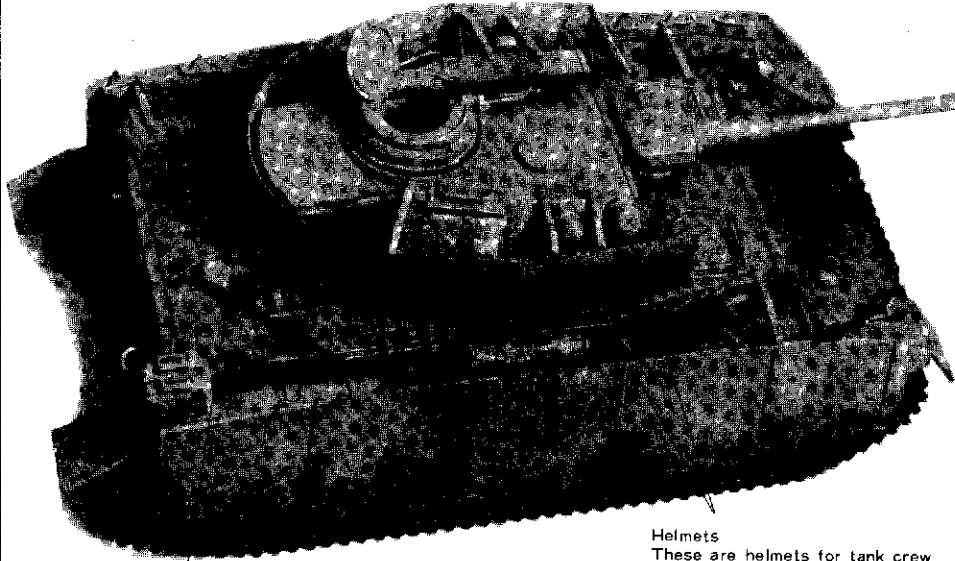

Wire Ropes
This shows the wire ropes fitted in the front hook. Give your ropes a natural curve, and paint them metallic grey.

Helmets
These are helmets for tank crew when fighting on the ground. Since tanks were limited in interior space, helmets were hung outside. Paint them field grey.

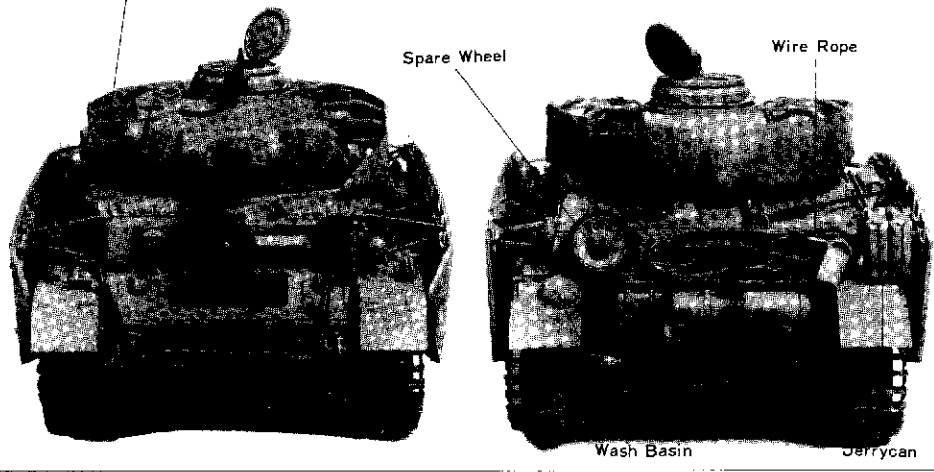

{Cans and Tubs for Painting}

Cans and tubs of these kind were used not only for carrying water but also as containers of paint for the tank. These were part of soldier's kit often seen in photographs of the battlefield. It is optional with you to mount them or not.

{Jerrycans}

Jerrycans were used for holding either fuel or drinking water. They were indispensable to tanks fighting in the desert or on the front far from the supply base.

{Helmets}

Tank men wore a helmet when they dismounted from their tank fight on the ground. Since tanks were limited in interior space, helmets were often hung outside the turret. From the latter half of 1943 onward, tank crew's helmets were not contained in their standard personal equipment but were often seen on the battlefield.

{Armour Plates}

With the progress of tanks, anti-tank projectiles improved in power. As tank armour became stronger, armour-piercing projectiles originally designed to penetrate armour became less effective and, therefore, hollow-charge projectiles came to be used against tanks. The hollow-charge projectiles were designed to explode on the surface of armour plate and emit high-temperature jet, which melted the armour plate and destroyed the interior of the tank. Armour plates were fixed so that hollow-charge projectiles might explode on their surface, not directly on armour surface. Later models, such as the Ausf J, in the Pzkw IV series had wire netting, instead of armour plates, which also served the purpose well.

{Cutting and Bending of Armour Plates}

Because tanks often received projectiles and ran against obstacles on the battlefield, many of their armour plates were partially lost or bent. It may be

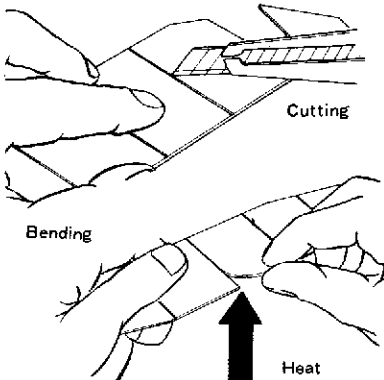

interesting to create a suitable atmosphere by cutting off some parts from the plates and slightly bending the cut edges.

The photograph on the next page shows a real tank and its armour plates damaged by projectiles in actual fighting. Represent such damage by melting plastic with a hot nail or the like. If you fail in this work, your elaborate model tank may become unsightly. Before starting the work, be sure to do some practice with a piece of plastic sheet or unnecessary plastic.

Fixing of Accessories

{Track Mounting Example}

Some tanks strengthened their front and upside by these track location shown. This location lays emphasis on using them as protection aid more than as spare tracks.

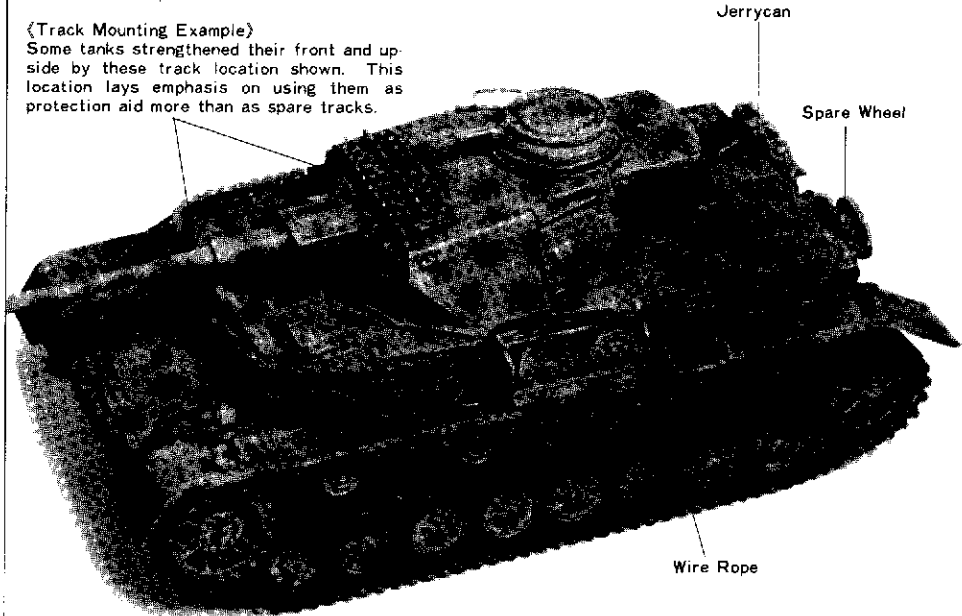

{Modelling Example of Armour Plate}

Spare Wheels

Also spare wheels were often fixed rather freely. This case shows one installed to the front.

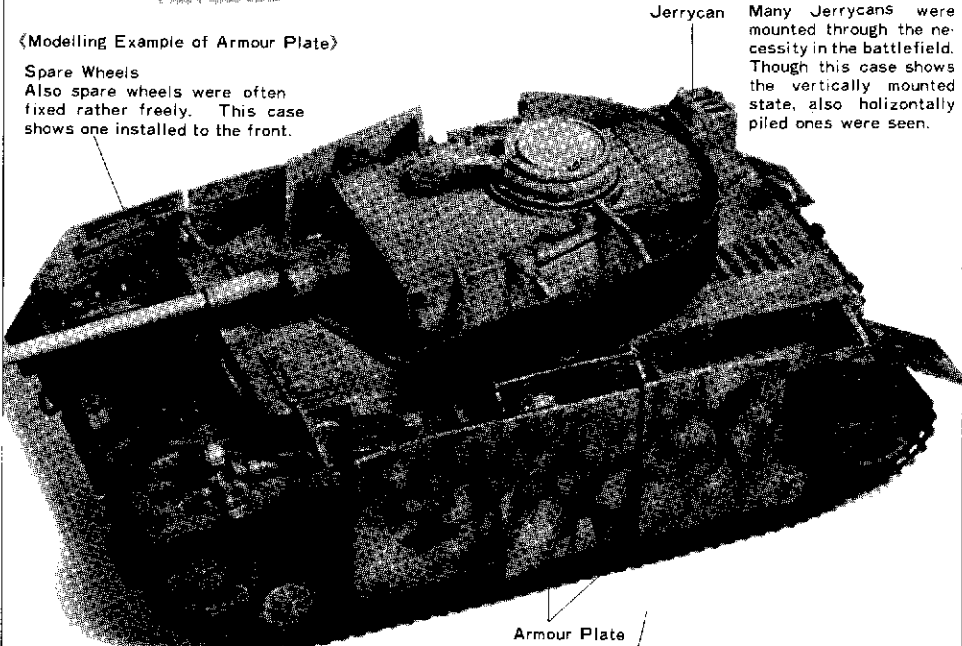

{Example of Rear Parts Installation}

Jerrycans

In order to distinguish from fuel containers, the Germans painted white cross on jerrycans containing water.

Armour Plate

This shows the modelling example of armour plates bent during the battle. As the actual armour plates had been rather thin plate of iron, they were curved or even dropped from the tank.

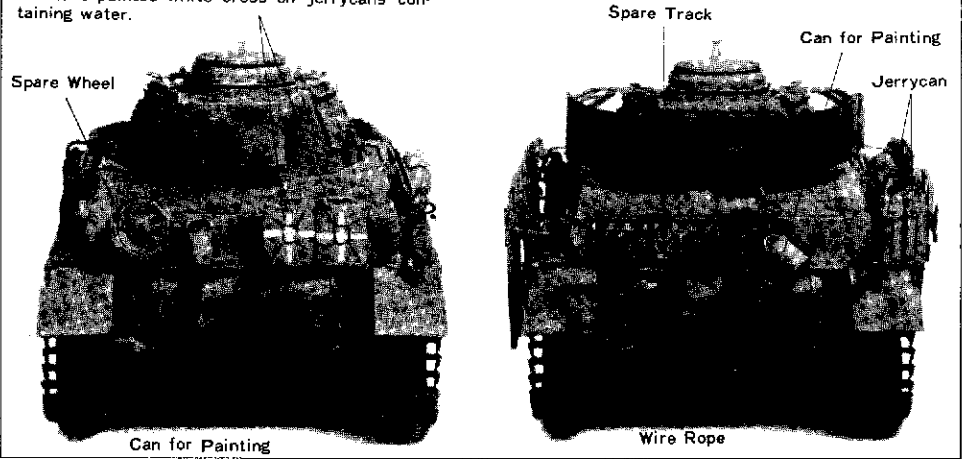

16 (Fixing of Armour Plate Stays)

Fix each Stay to Upper Hull and then fix both ribs in place.



(Pzkwfw III's Broken Plate)

17 (Construction of Armour Plates)

See the photograph below of full size. Put parts on it and adjust their angle accordingly.

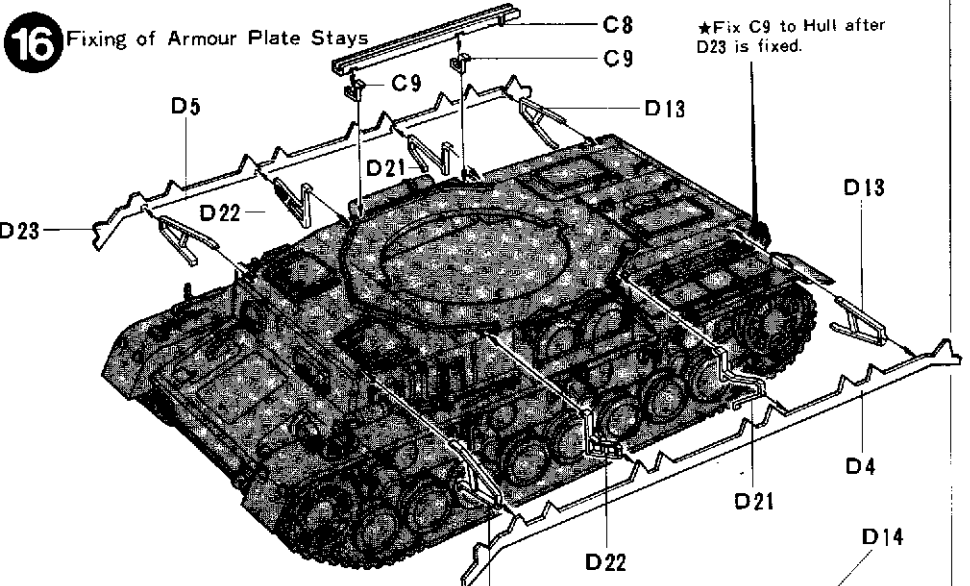
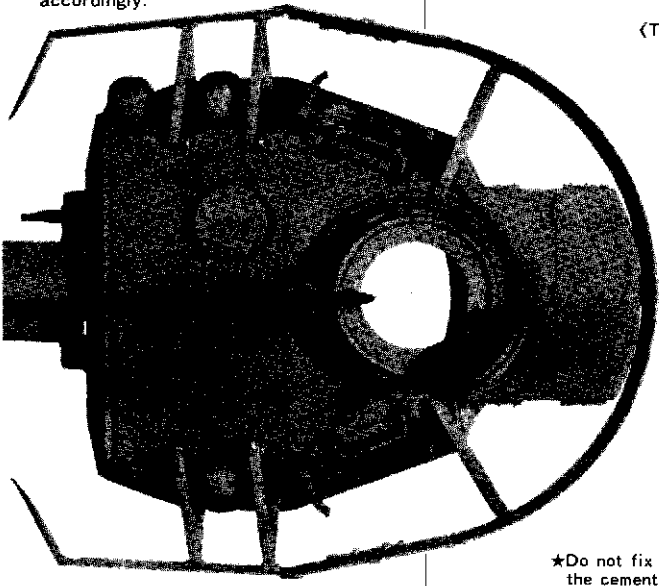

★Fix C9 to Hull after D23 is fixed.

17 Construction of Armour Plates

(Turret Armour Plate)

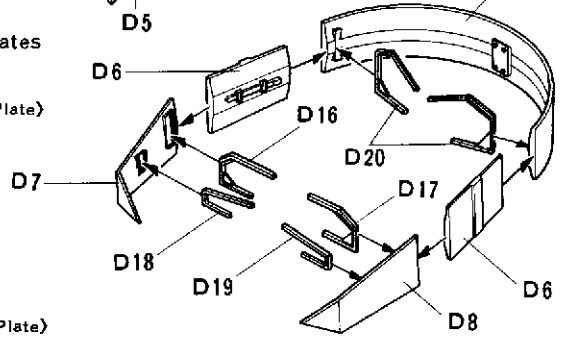

(Hull Armour Plate)

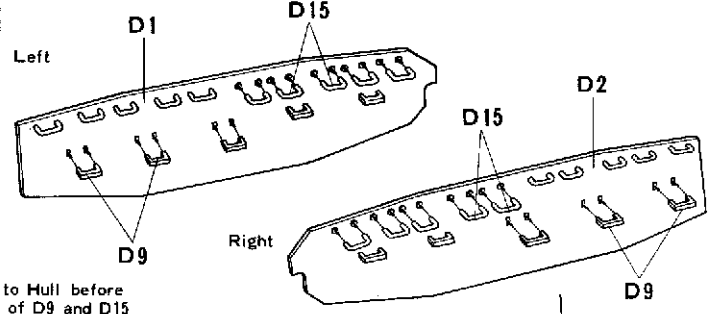

★Do not fix to Hull before the cement of D9 and D15 dries completely.

18 Fixing of Armour Plate

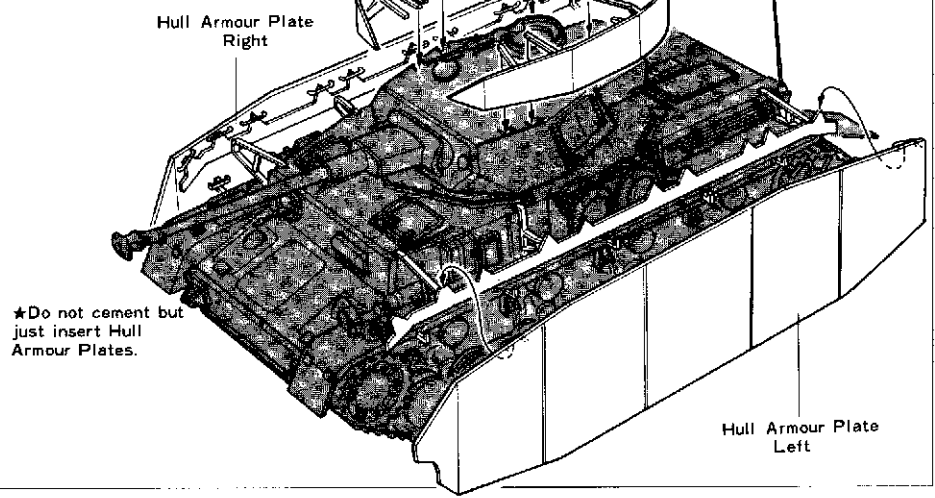

★Do not cement but just insert Hull Armour Plates.

PAINTING



APPLYING DECALS

《Painting of the PzKpfw IV Ausf H》
 The PzKpfw IV Ausf H was put to production in March 1943. On 18th February of that year, the German Army authorities ordered to use dark yellow as the basic colour of vehicles in place of German grey which had been used as such use until that time. Therefore, the PzKpfw IV Ausf H was basically painted dark yellow. Field forces, however, often put other colours for camouflage on the basic colour according to the terrain of the battlefield where they fought. There were no fixed camouflage patterns. They freely put red brown, and/or dark green on the basic colour by means of brushes or spray guns.

《Marking of the PzKpfw IV》
 PzKpfw IV tanks wore divisional marks and turret numbers. The turret numbers each consisted of three figures representing the company, platoon and vehicle number. See the organization chart at right.

《Divisional Mark》

Wehrmacht 2nd Panzer Div.	Wehrmacht 3rd Panzer Div.	Wehrmacht 11th Panzer Div.
Wehrmacht 116th Panzer Div.	Wehrmacht Grossdeutschland	SS 1st SS Panzer Div.
SS 2nd SS Panzer Div.	SS 3rd SS Panzer Div.	SS 9th SS Panzer Div.

《How to Apply Camouflage with Spray Paint》

- (1) Get cotton, paste and spray-type paint for plastic ready for use.
- (2) Paint the model tank overall in camouflage colour. Do not proceed to the next work until the paint becomes completely dry. (Dry it for about one hour.)
- (3) Partially mask the camouflage colour with pieces of cotton with reference to the camouflage figures. Cotton should be taken to pieces and stuck with a little paste.
- (4) Spray the basic colour overall. Dry it completely. Then, remove the cotton and rinse the model tank.

《Painting Armour Plates》

Spray of Camouflage Colour

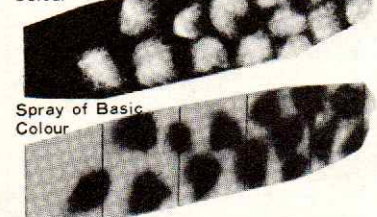

Spray of Basic Colour

Standard Formation of German Panzer Division (as of 1944)

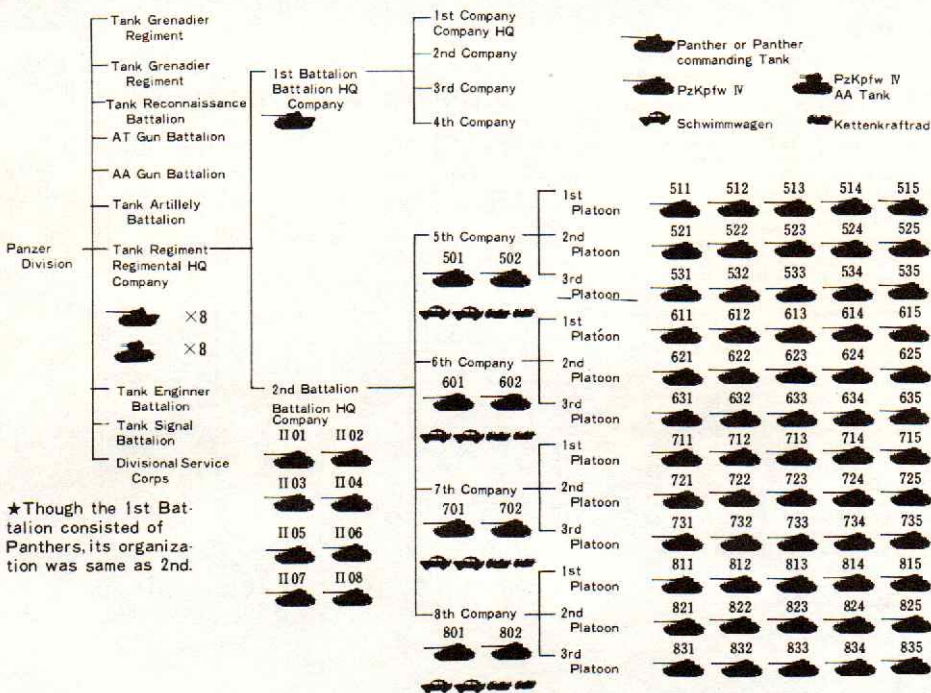

★ Though the 1st Battalion consisted of Panthers, its organization was same as 2nd.

《Position of Marks When Armour Plates Are Installed》

Camouflage: with spray gun Turret number

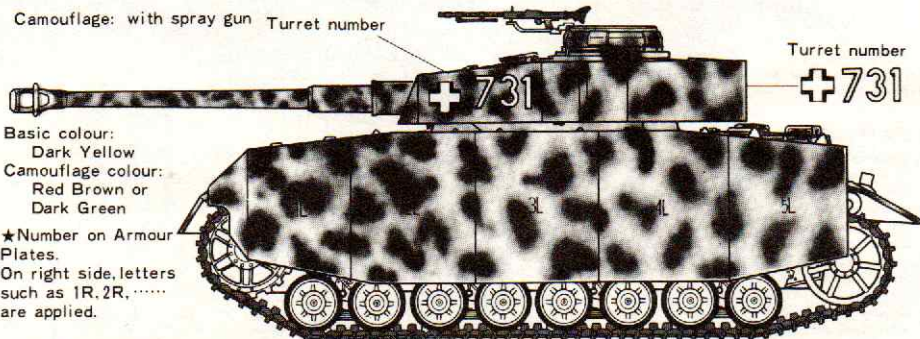

Basic colour:
 Dark Yellow
 Camouflage colour:
 Red Brown or
 Dark Green

★ Number on Armour Plates.
 On right side, letters such as 1R, 2R, are applied.

《Position of Divisional Mark》

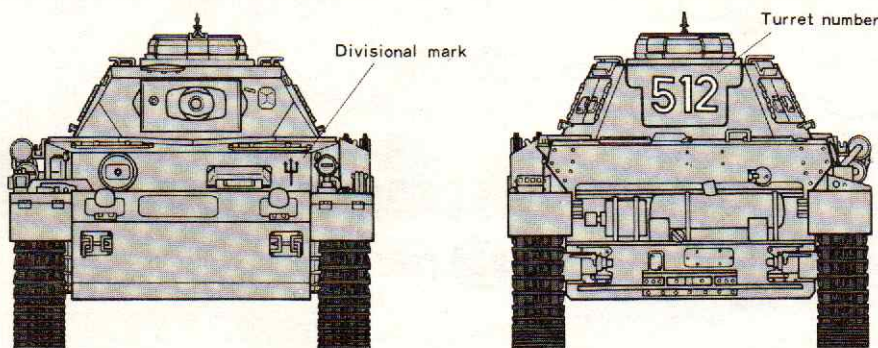

《Position of Marks Without Armour Plates》

Camouflage: with brush

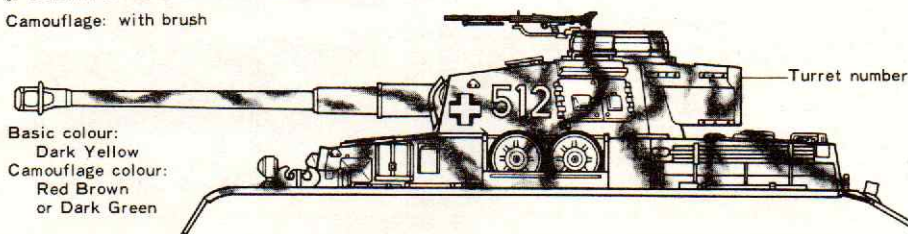

Basic colour:
 Dark Yellow
 Camouflage colour:
 Red Brown
 or Dark Green

★ Also some tanks were applied dark green and red brown camouflage of stripe-like pattern on dark yellow base.

PARTS

A PARTS

1. Rear Wheels A
2. Rear Wheels B
3. Road Wheels A
4. Road Wheels B
5. Unnecessary
6. Final Cover Right
7. Upper Rollers A
8. Suspension Right
9. Drive Sprocket A
10. Drive Sprockets B
11. Upper Rollers B
12. Final Cover Left
13. Unnecessary
14. Suspension Left
- 15, 16, 17, 18. Unnecessary

B PARTS

2. Loading Section Part B
3. Loading Section Part A
4. Tool Box Fixing Parts B
5. Machine Gun
6. Barrel Top
7. Barrel Base
8. Loading Section Holder A
9. Loading Section Holder B
10. Handrails
11. Machine Gun Rack B
12. Turret (Left)
13. Turret (Right)
14. Hooks
15. Cartridge Holder
16. Gun Shield
17. Turret Top Plate
18. Protection Rail B
19. Barrel A
20. Barrel B
21. Tool Box Fixing Parts C
22. Tool Box Fixing Parts A
23. Hatch Hinges
24. Recoil Mechanism
25. Loading Section (Left)
26. Protection Rail A
27. Handle
28. Protection Rail C
29. Loading Section (Right)
30. Recoil Protector
31. Muzzle Brake A
32. Muzzle Brake B
33. Cupola C
34. Cupola B
35. Turret Ring
36. Turret Front
37. Tool Box B
38. Tool Box A
39. Turret Side Hatch A
40. Turret Side Hatch B
41. Turret Side Hatch C
42. Turret Side Hatch D
43. Machine Gun Rack A
44. Cupola A
45. Hatch
46. Ventilator
47. MG34
48. Hatch Stopper A
49. Hatch Stopper B
50. Shelters

C PARTS

1. Spanner
2. Wrench
3. Nut Wrench
4. Shovel
5. Cleaning Rod
6. Wire Cutter
7. Crank
8. Antenna Holder A
9. Antenna Holder B
10. Ax
11. Hook Holder
12. Jack Base
13. Jack Handle
14. Jack Body
15. Driver's Vision Port
16. Front Armour Plate
17. Spare Wheels B
20. Spare Wheels A
18. Air Cleaner (Inside)
19. Air Cleaner (Outside)
21. Air Cleaner Pipe B
22. Air Cleaner Pipe A
23. Air Cleaner (Left)
24. Air Cleaner (Right)
25. Pipe Base
26. Driver's Window
27. Barrel
28. Machine Gun Rack
29. Unnecessary
30. Hull Parts A
31. Driver's Hatch
32. Wireless Operator's Hatch
33. Air Intake Covers
34. Jack Base
35. Hull Part B
36. Springs
37. Fire Extinguisher
38. Hooks
39. Wheel Stopper B
40. Wheel Stopper A
41. Wheel Stopper D
42. Light
43. Hull Part C
44. Taillight
45. Wheel Stopper C
46. Rear Fender Left
47. Rear Fender Right
48. Handrails
49. Front Hook A
50. Antenna Base
51. Shaft Bearing Parts C
52. Hook B
53. Hook A
54. Rear Panel Lower
55. Rear Panel Upper
56. Rear Hook A
57. Rear Hooks C
58. Generator C
59. Shaft Bearing Part A
60. Shaft Bearing Part B
61. Cap
62. Muffler Supports
63. Muffler B
64. Muffler A
65. Generator B
66. Generator A
67. Muffler C
68. Muffler D
69. Rear Fender A
70. Rear Fender B
71. Muffler E
72. Rear Hook B
73. Front Hook B
74. Unnecessary

A PARTS

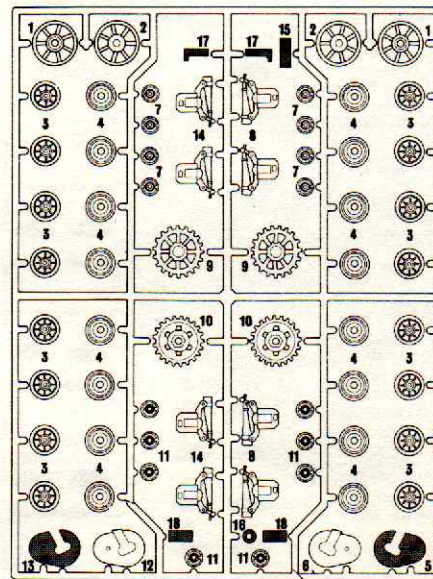

B PARTS

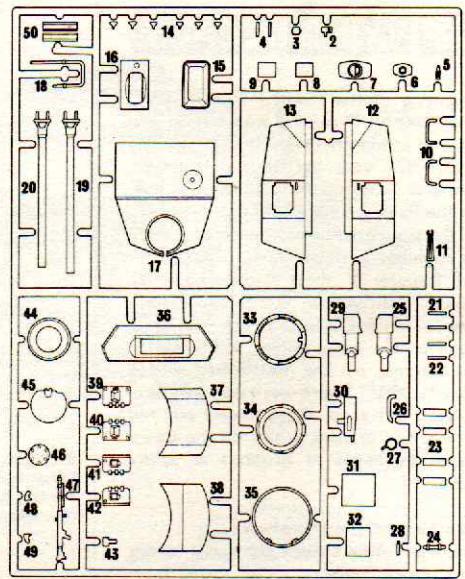

C PARTS

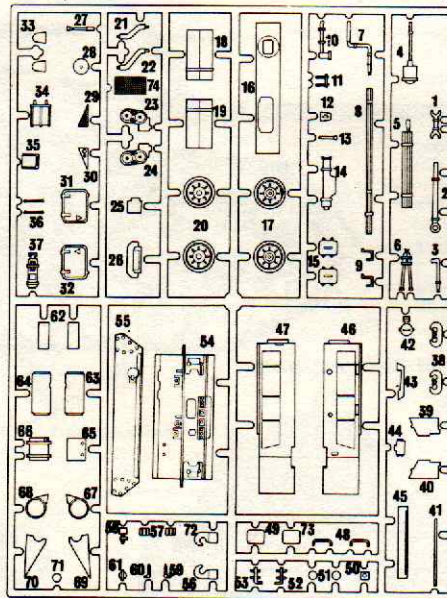

D PARTS

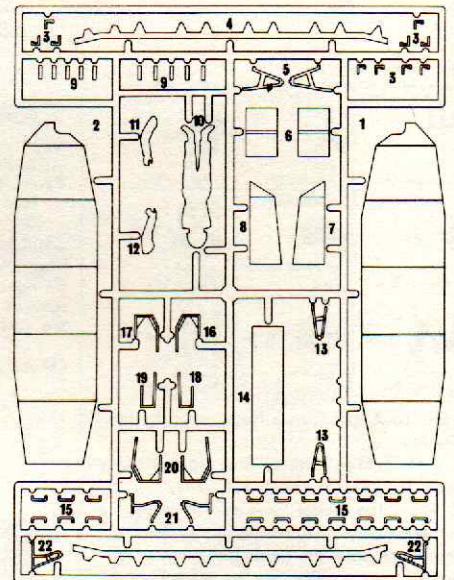

E PARTS

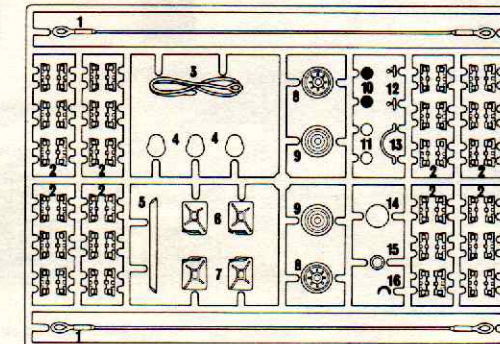

D PARTS

1. Armour Plate A
2. Armour Plate B
3. Fixing Hooks A
4. Armour Plate Rib Left
5. Armour Plate Stays A
6. Turret Covers A
7. Turret Cover B
8. Turret Cover C
9. Fixing Hooks C
10. Figure Body
11. Figure Right Arm
12. Figure Left Arm
13. Armour Plate Stay B
14. Turret Cover E
15. Armour Plate Parts
16. Turret Cover Stay A
17. Turret Cover Stay B
18. Turret Cover Stay C
19. Turret Cover Stay D
20. Turret Cover Stays E
21. Armour Plate Stay C
22. Armour Plate Stay D
23. Armour Plate Rib Right