

PzBefWg Panther Ausf. G

KIT NO:904

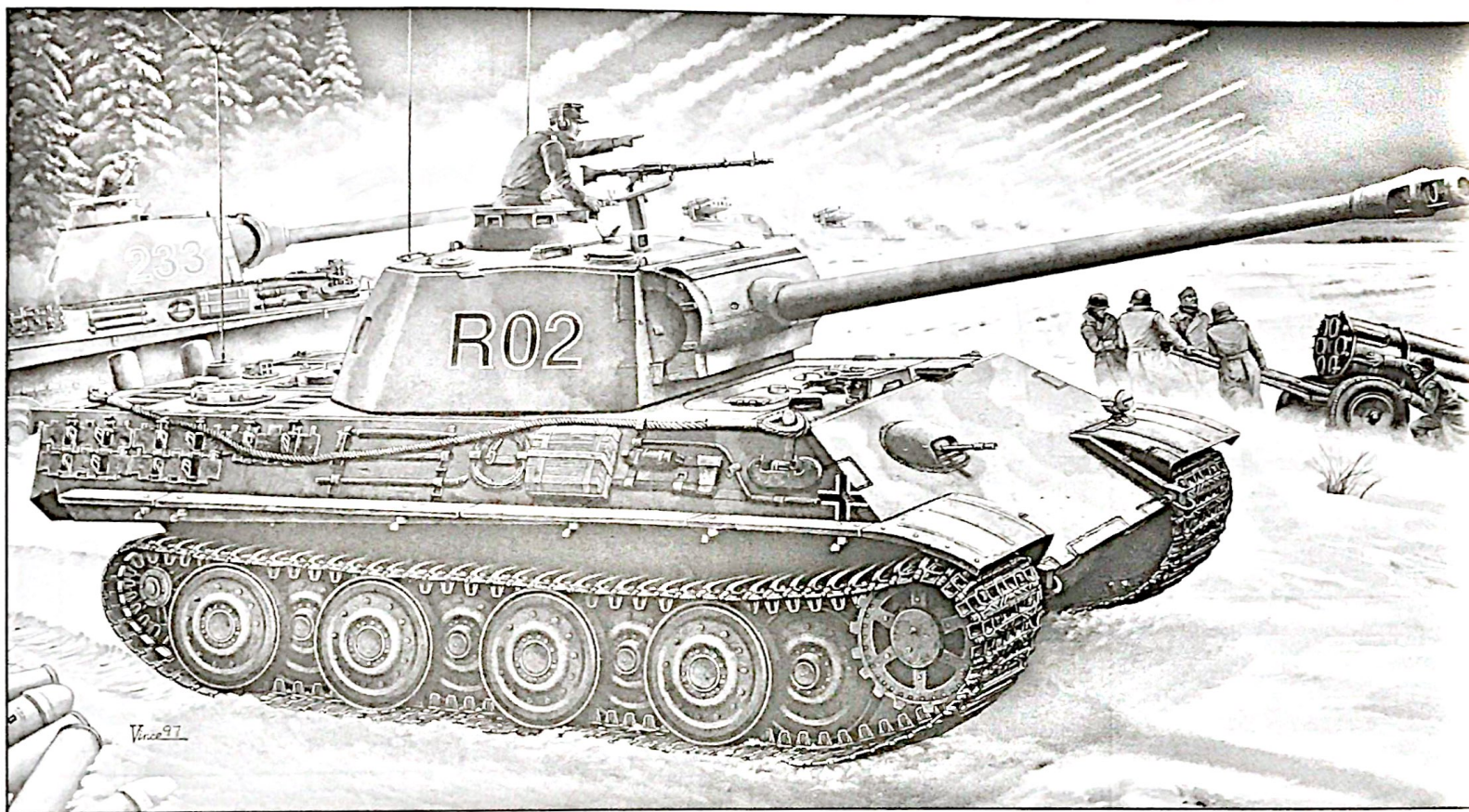

Technical assistance provided by THOMAS ANDERSON



A

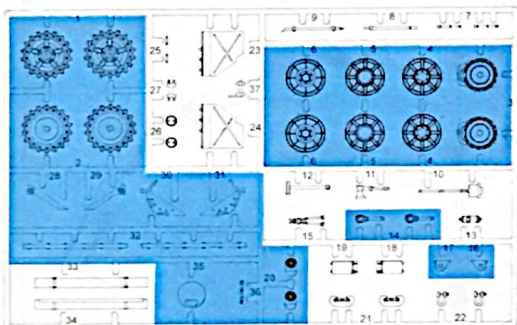

B

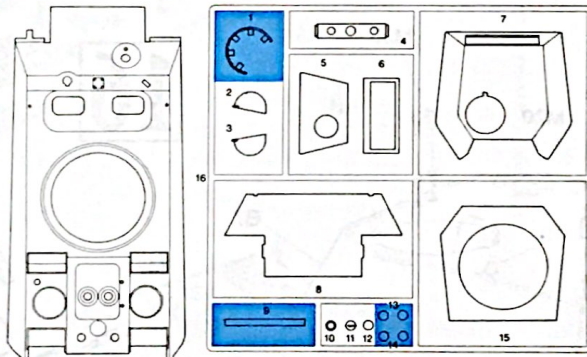

Cx2



Cx4



Cx4

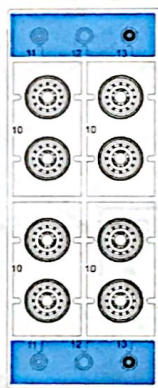

Jx4

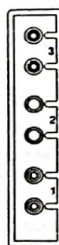

Ex2

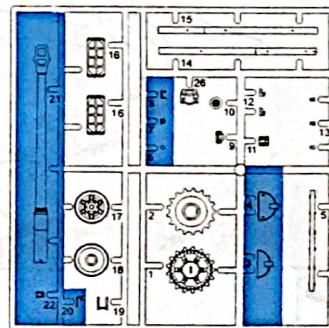

F

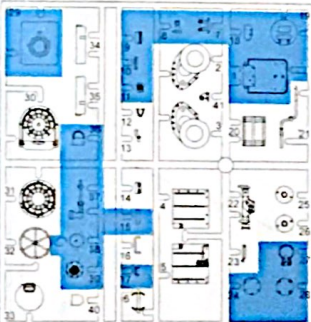

M

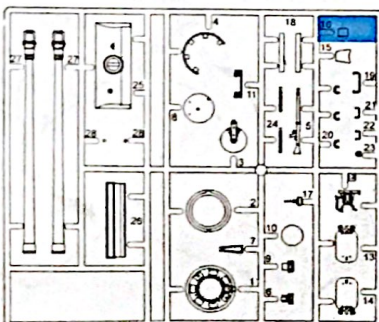

N

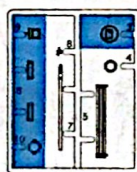

G

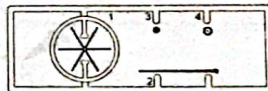

H

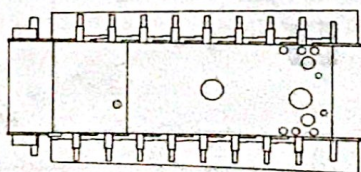

の部品は使用しません
 Parts not for use
 Teile werden nicht verwendet
 Pièces à ne pas utiliser
 Parti non utilizzati
 不需要使用的部件

組立ての注意

- 接着剤や塗料は火に近くて使わないでください。使う時はときどき窓を開けて換気に気をつけましょう。
- 塗料指定の **1** はグンゼ産業・Mr.カラーの番号です。接着剤や塗料は入っていませんので別にお買い求めください。
- 部品をランナーから切り離す時は模型用ハサミ等を使い、余分な部分はカッターやヤスリ等で仕上げてください。
- 組立図のサインマークは下の説明をこらんでください。

(注意)

- 勿於近火處使用膠水或油漆，並打開窗戶保持空氣流通。
- **1** 代表都是產業出品MR.COLOR 的顏色編號，不包括膠水及油漆。
- 自膠架中取出部件時，應用模型專用剪，並用剪刀或小銼除去多餘的膠料。
- 各圖型的含意可參考本欄以下的說明。

ZUR BEACHTUNG

- Kleber und Farbe nicht nahe von offenem Feuer verwenden und das Fenster von Zeit zu Zeit zur Belüftung öffnen.
- Der **1** der Farbkennzeichnung bedeutet die Farbnummer von GUNZE SANGYO MR. COLOR Kleber und Farbe sind nicht enthalten.
- Zum Abschneiden der Teile vom Verbundstück eine Modellierschere verwenden und die überstehenden Plastikteile mit einem Messer oder einer Feile beseitigen.
- Die Bedeutung der Symbols finden Sie unten in dieser Spalte.

CAUTION

- When you use glue or paint, do not use near open flame and use in well ventilated room.
- **1** of color indication refers to the color number of GUNZE SANGYO MR. COLOR Glue and paint are not included.
- When you take parts off from the runner frame, use a modeling scissors and trim excess plastic with a cutter or a file.
- See the bottom of this column for the meaning of symbols.

ATTENTION

- Ne pas utiliser de colle ou de peinture a proximite d'une flamme nue, et aerer la piece de temps en temps.
- Le numero **1** pour l'indication de couleurs correspond au numero de couleur de GUNZE SANGYO MR. COLOR La colle et la peinture ne sont pas comprises.
- Pour retirer les pieces hors du cadre, utiliser des ciseaux spéciaux pour maquette et retirer le plastique en excès avec un cutter ou une lime.
- Voir la fin de cette colonne pour la signification des symboles.

ATTENZIONE

- Non usare colla e vernice vicino a fiamme esposte, e aprire le finestre di tanto in tanto per cambiare l'aria.
- **1** delle indicazioni di colore si riferisce al numero di colore di GUNZE SANGYO MR. COLOR Colla e vernice non sono incluse.
- Quando si staccano parti del carrello, usare forbici da modellismo e eliminare la plastica in eccesso con un coltello o una lima.
- Vedere in fondo a questa colonna per il significato dei simboli.



H 1 GUNZE SANGYO AQUEOUS HOBBY COLOUR ITALERI PAINT NO. 1 GUNZE SANGYO MR. COLOUR

H12 33	つや消レブラック	1749	FLAT BLACK	MATTSCHWARZ	NOIR MAT	NERO OPACO	啞黑色
H18 26	黒鉄色	1415	STEEL	STAHL	ACIER	ACCIAIO	黒銀色
H37 43	ウッドブラウン	1735	WOOD BROWN	HOLZBRAUN	BRUN BOIS	HARRONE LEGNO	木棕色
H66 19	RLMサンディブラウン79	1706	RLM SANDY BROWN 79	RLM SAND GELB 79	RLM BRUN SABLE 79	SABBIA RLM 79	RLM砂褐79
H76 61	焼鉄色	1406	BURNT IRON	GEBR, EISEN	FER BRULÉ	FERRO BRUCIATO	焼鐵色
H80 54	カーキグリーン	1710	KHAKI GREEN	KHAKIGRÜN	VERT KHAKI	VERDE KAKI	カーキ綠色
H90 47	クリアレッド	1507	CLEAR RED	ROT, REIN	ROUGE CLEAR	ROSSO CHIARO	透明紅色

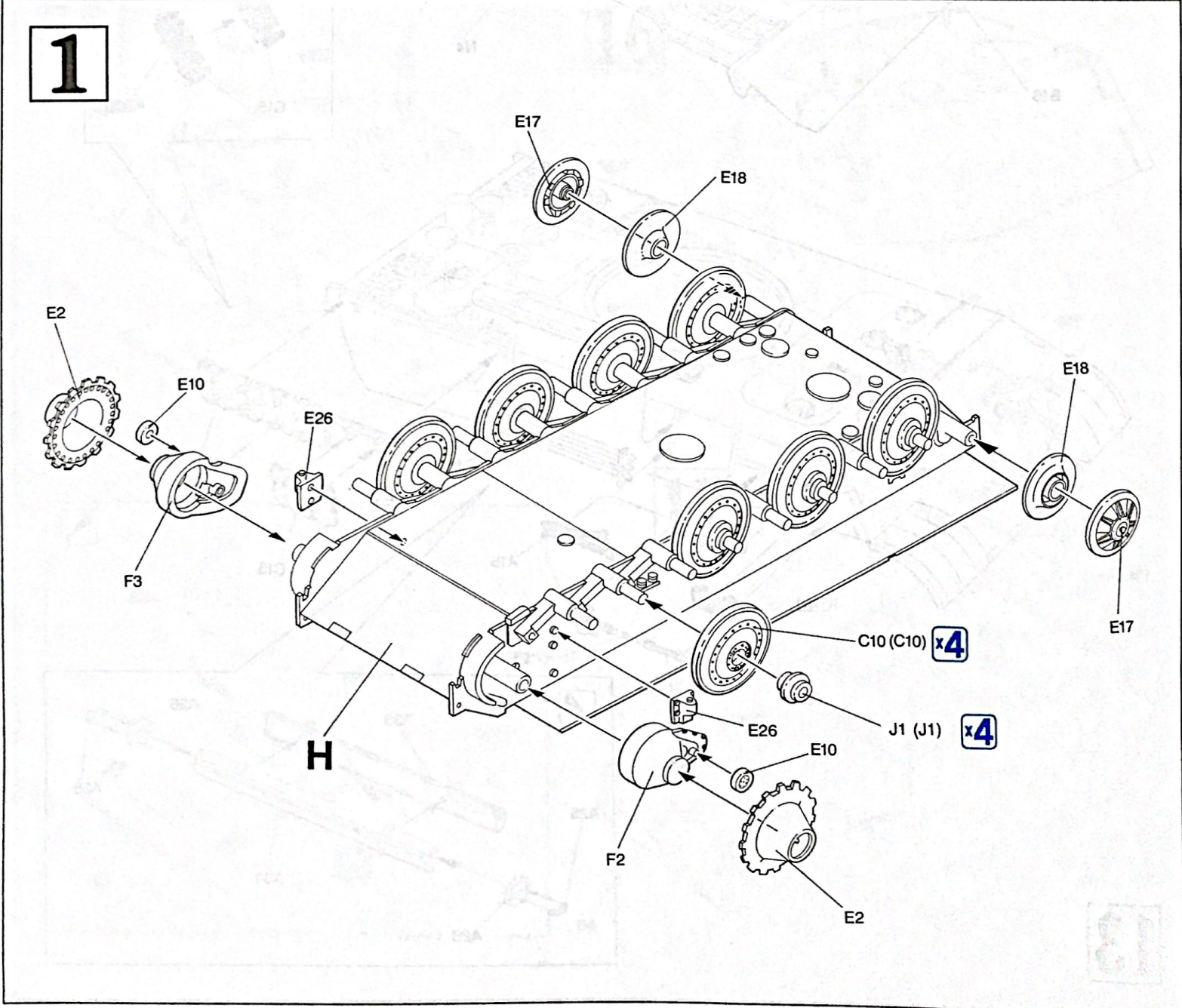

2

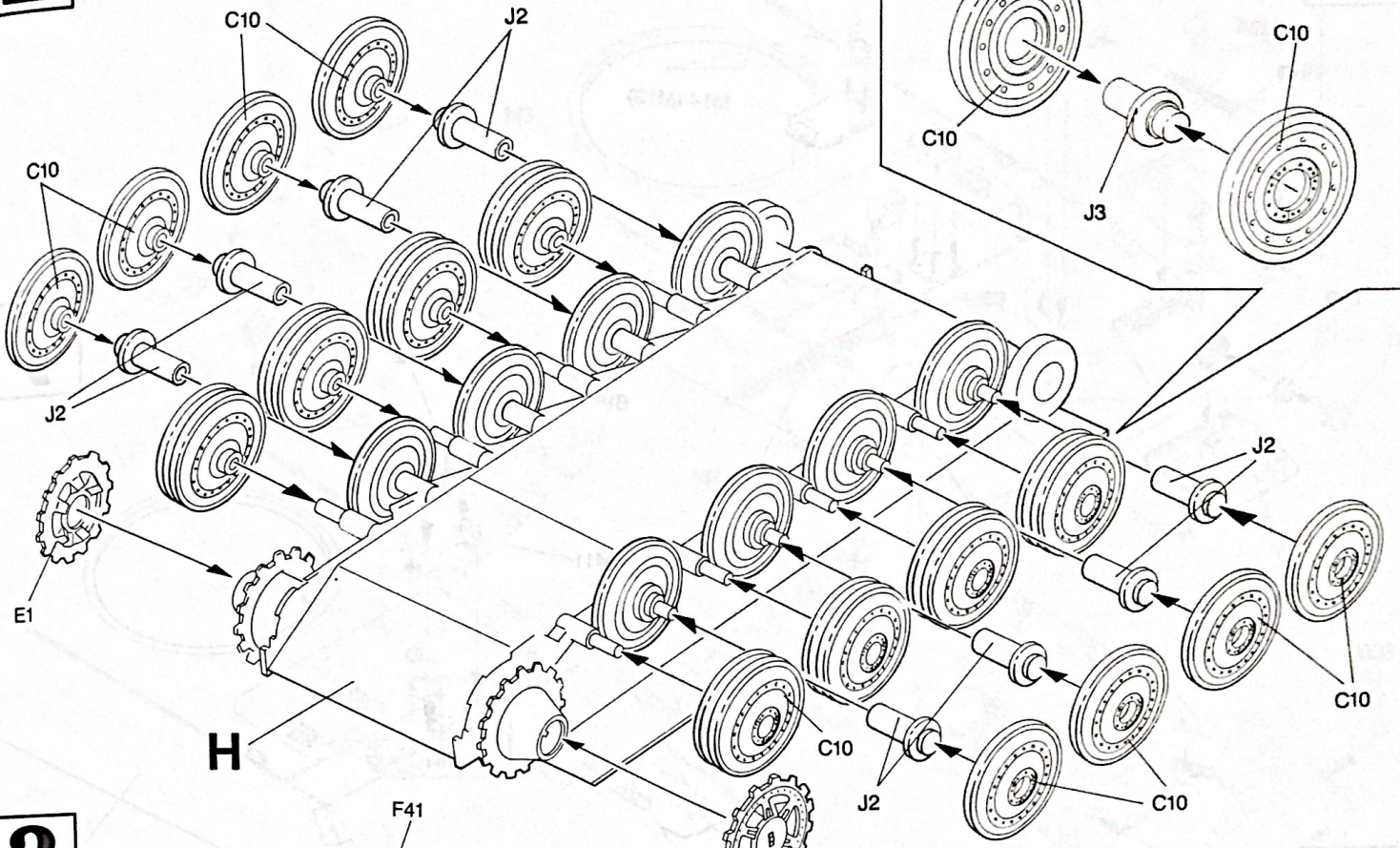

3

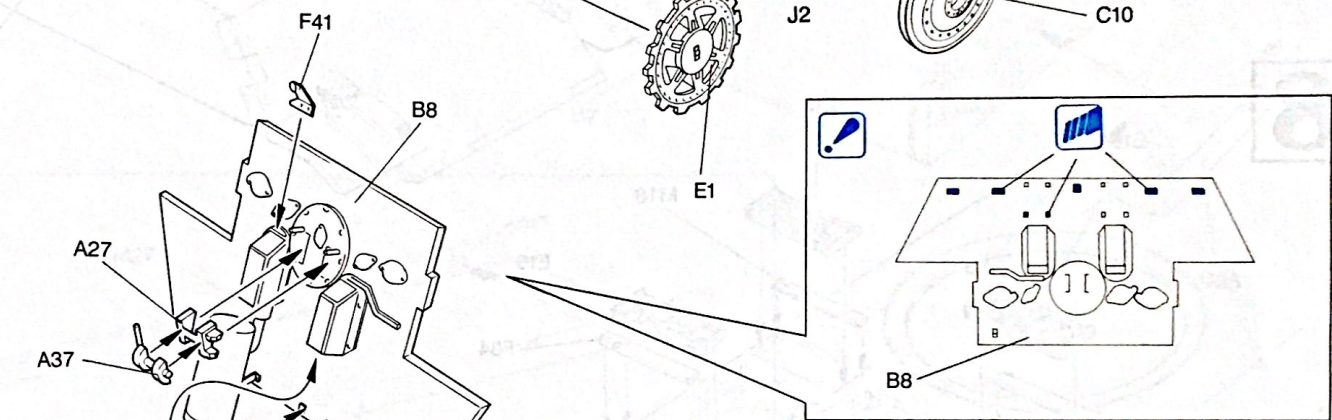

4

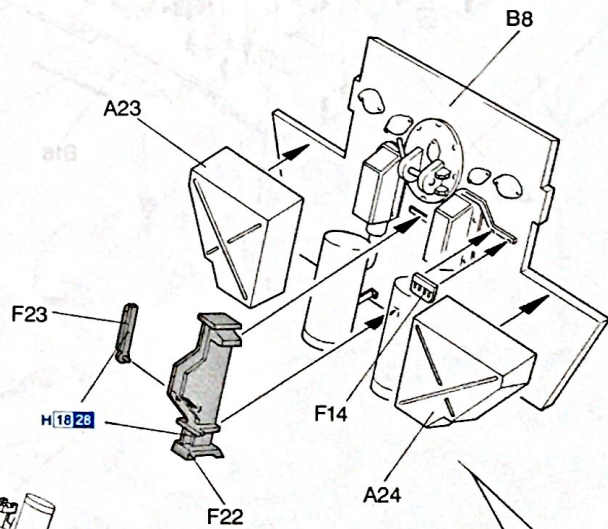
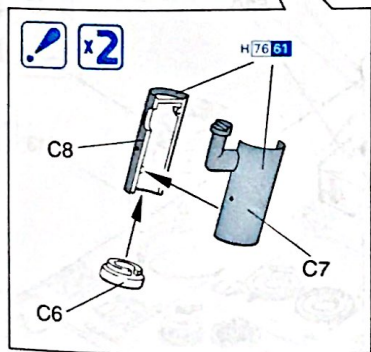

5

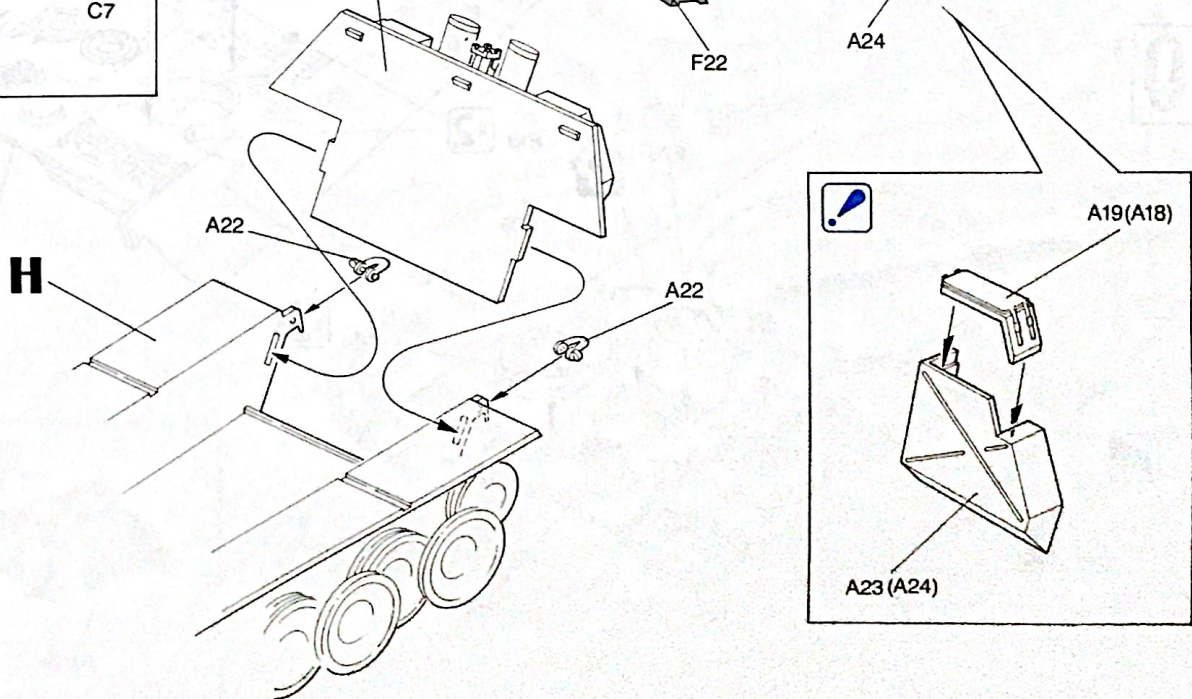

6

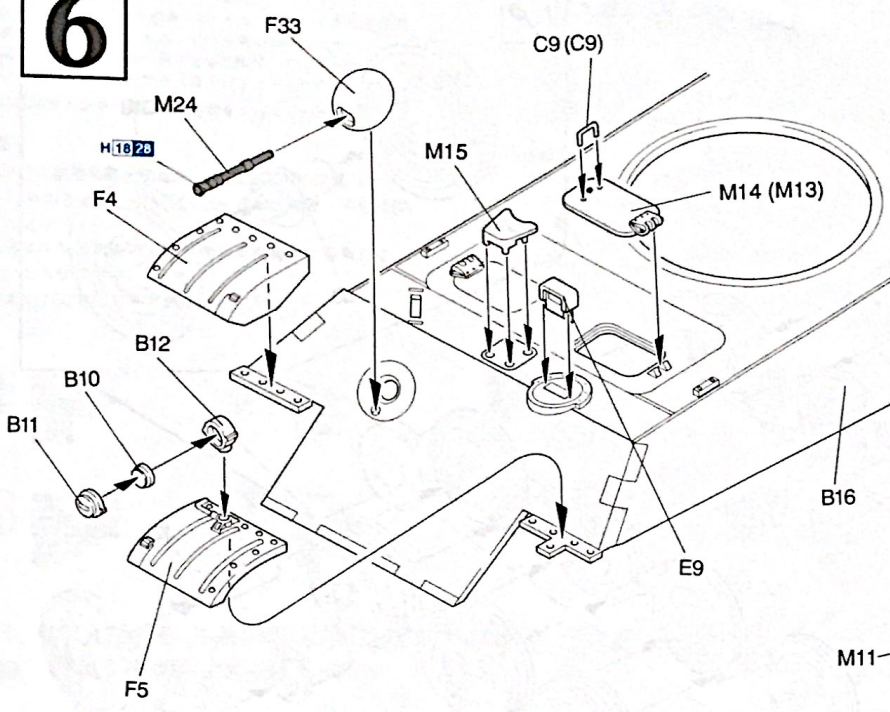

7

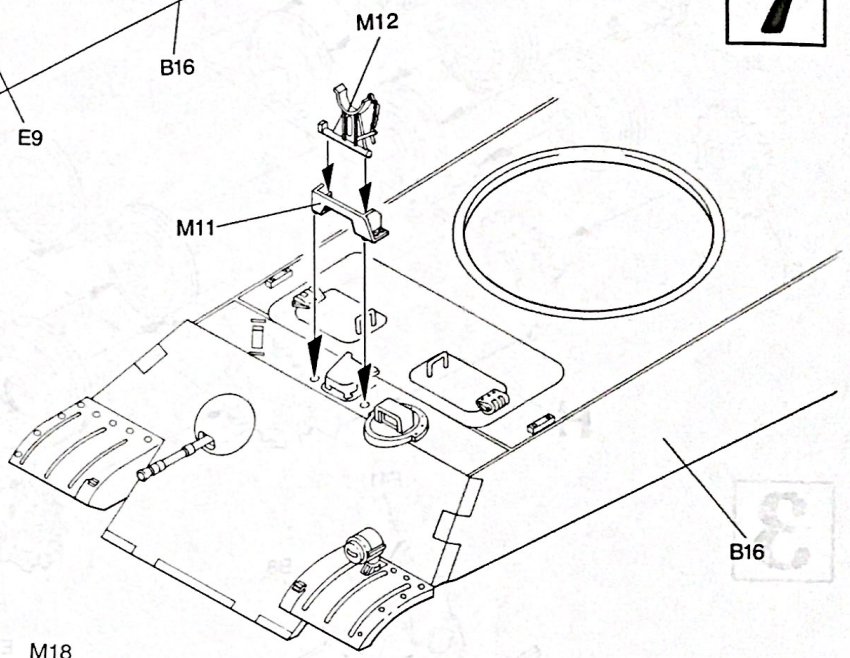

8

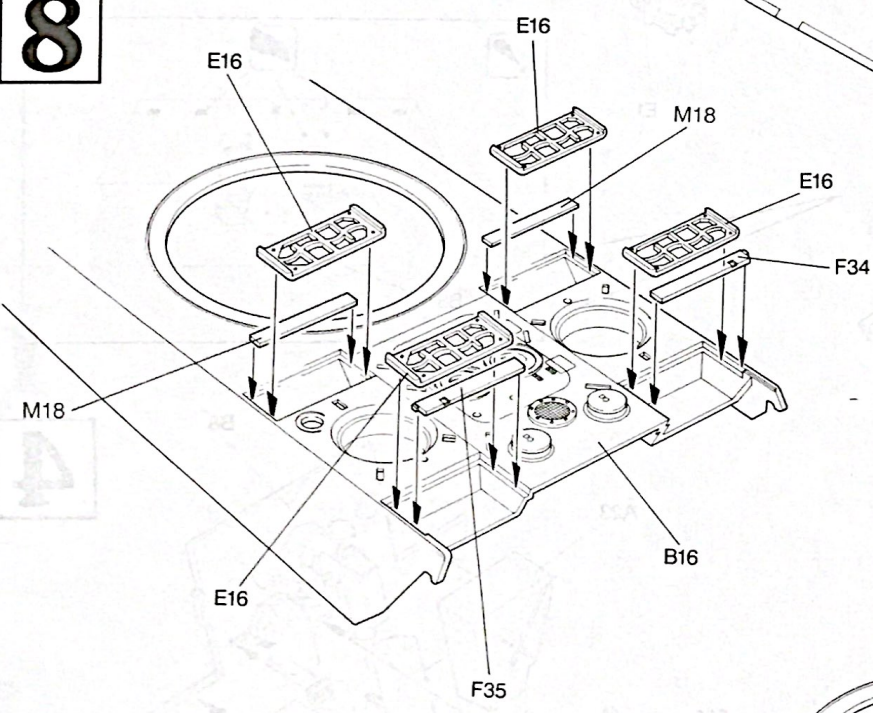

9

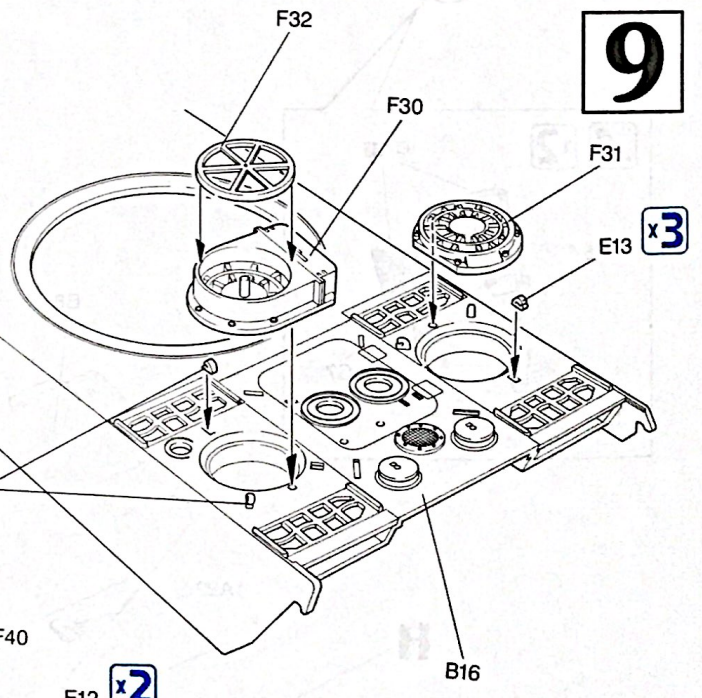

10

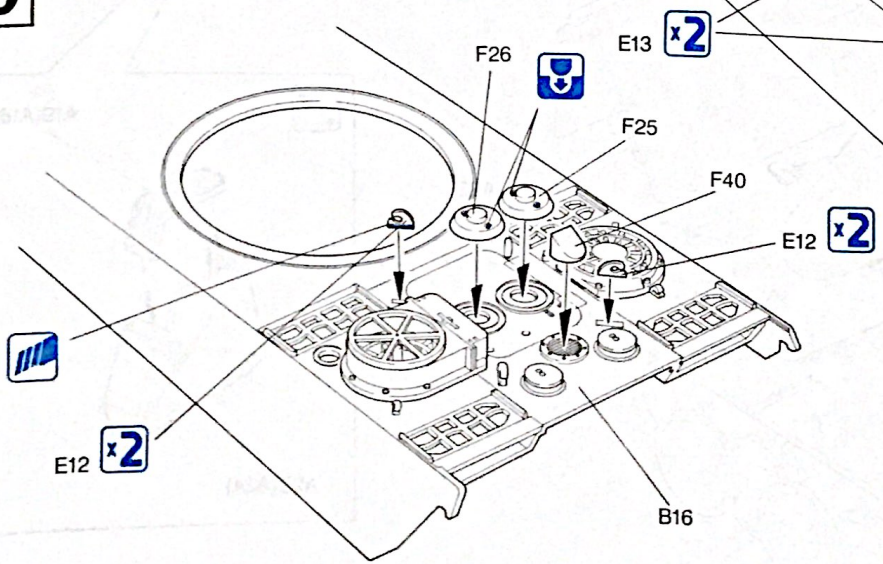

11

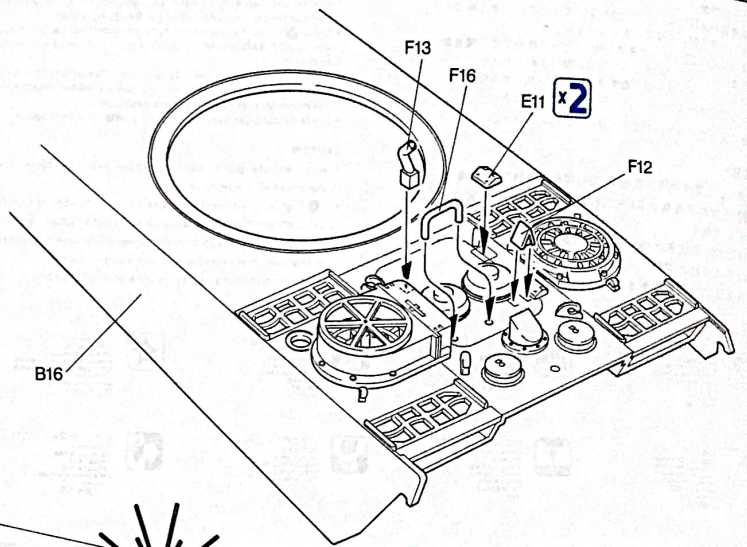

12

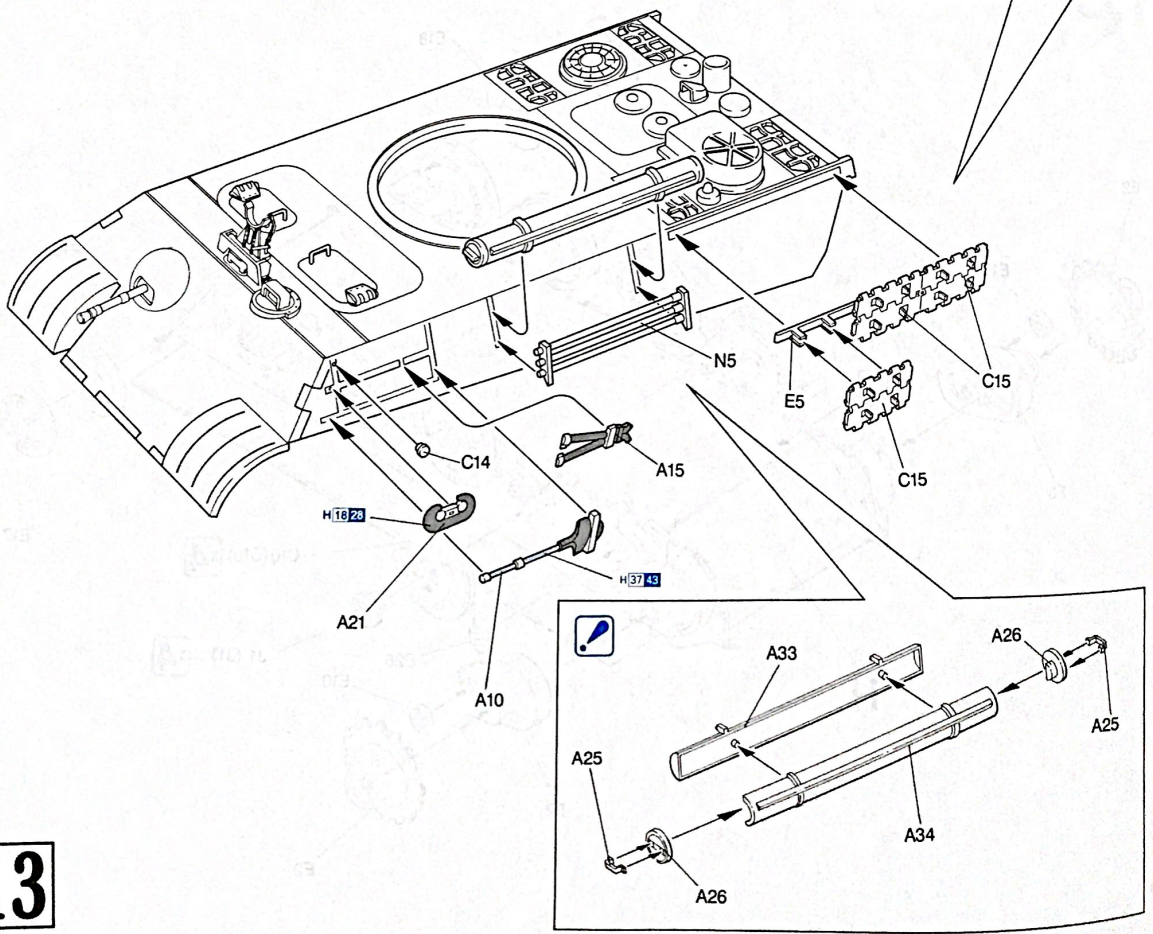
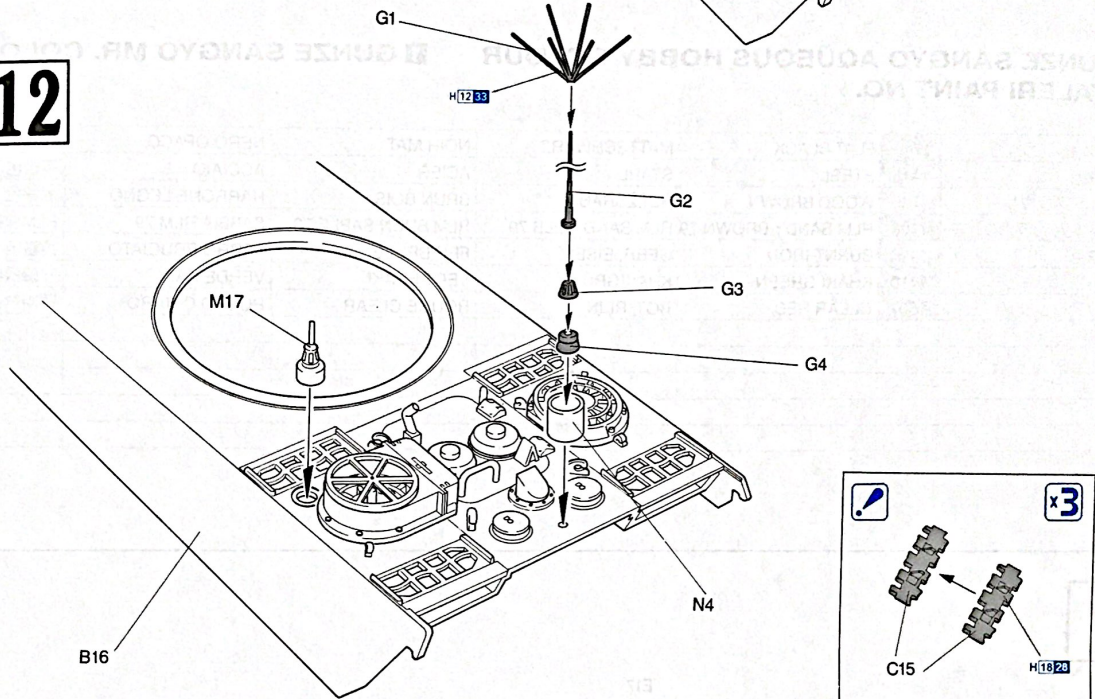

13

14

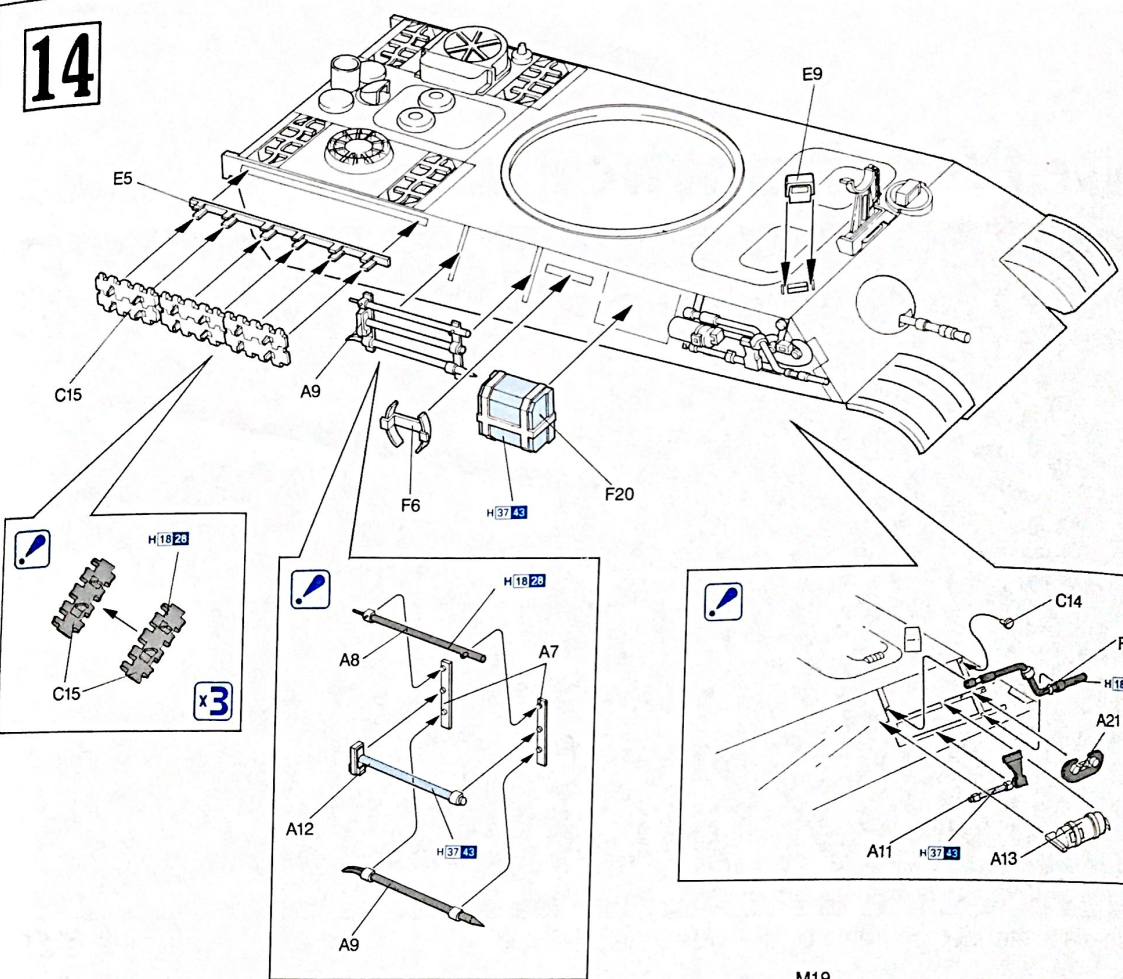

15

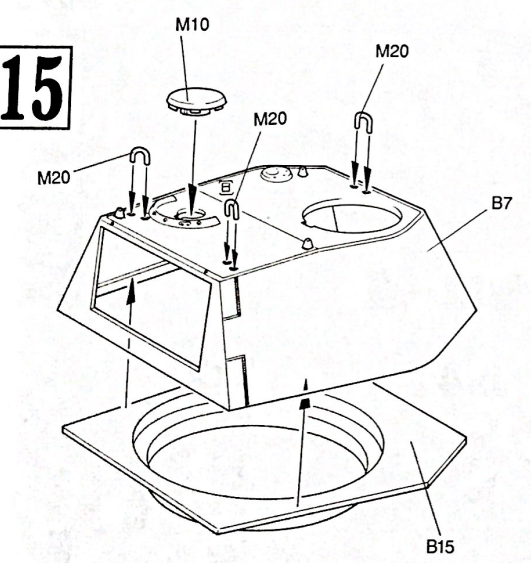

16

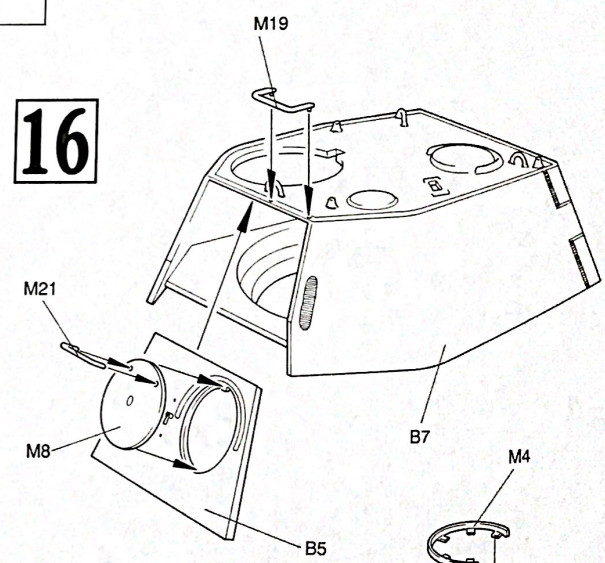

17

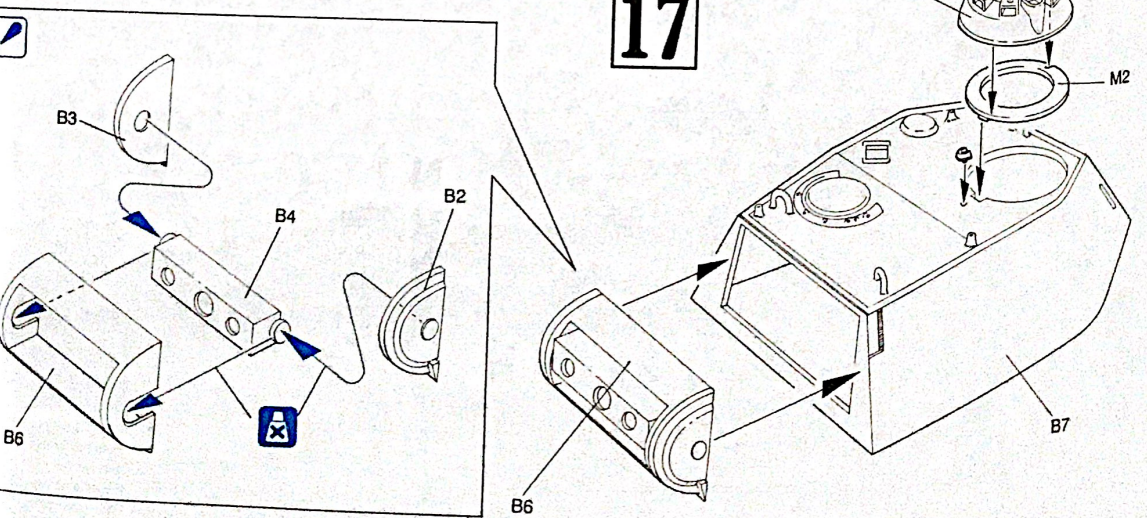

18

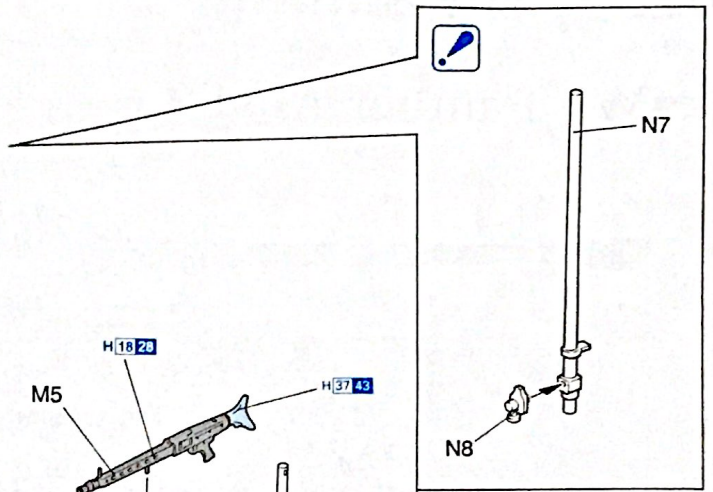
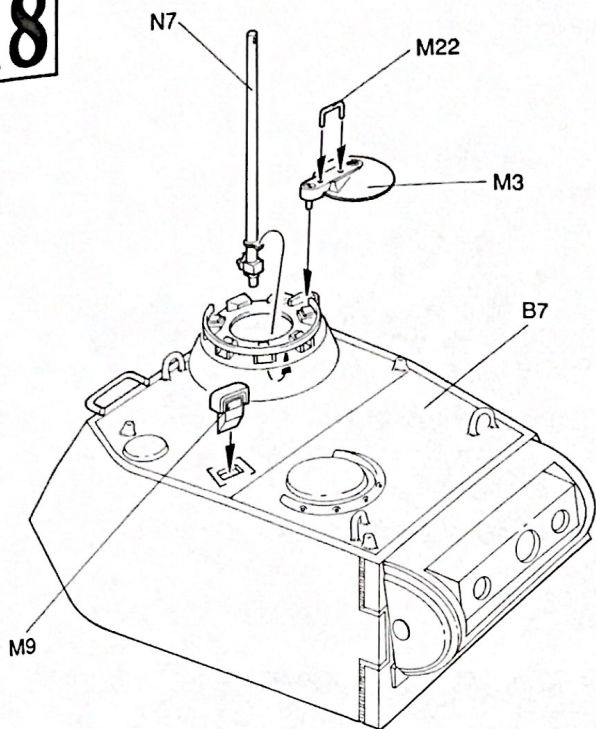

19

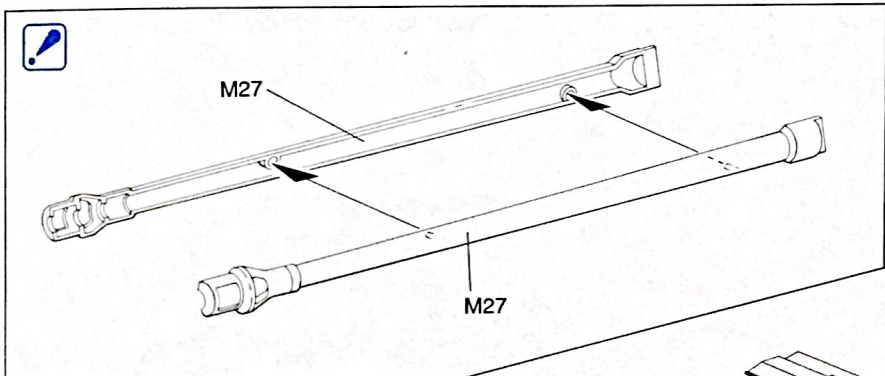
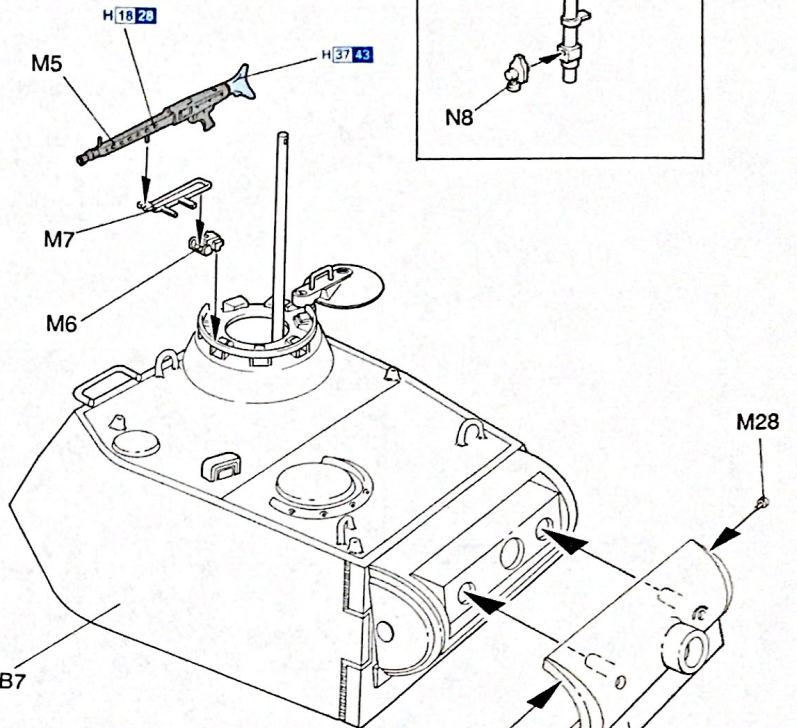

20

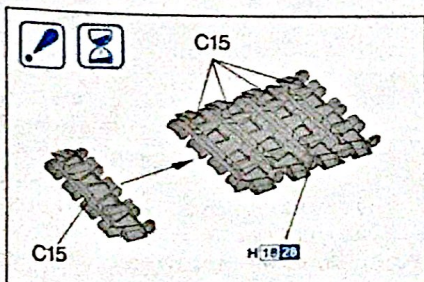
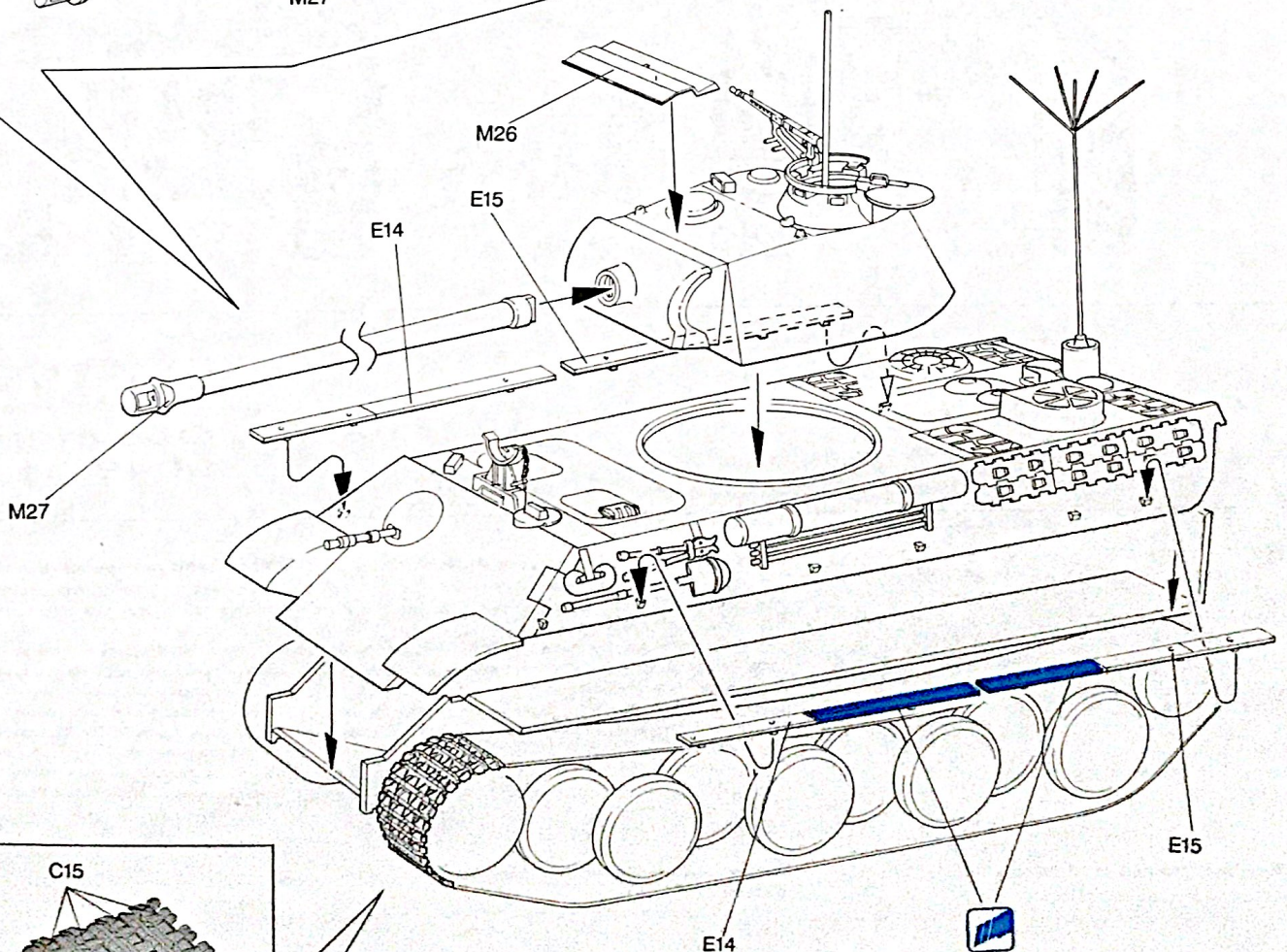

Marking & Painting

マーキング及び塗装図 Markierungen und Bemalung Decoration et Peinture Marchio & Pittura 標貼及着色指示

PzBefWg Panther Ausf. G

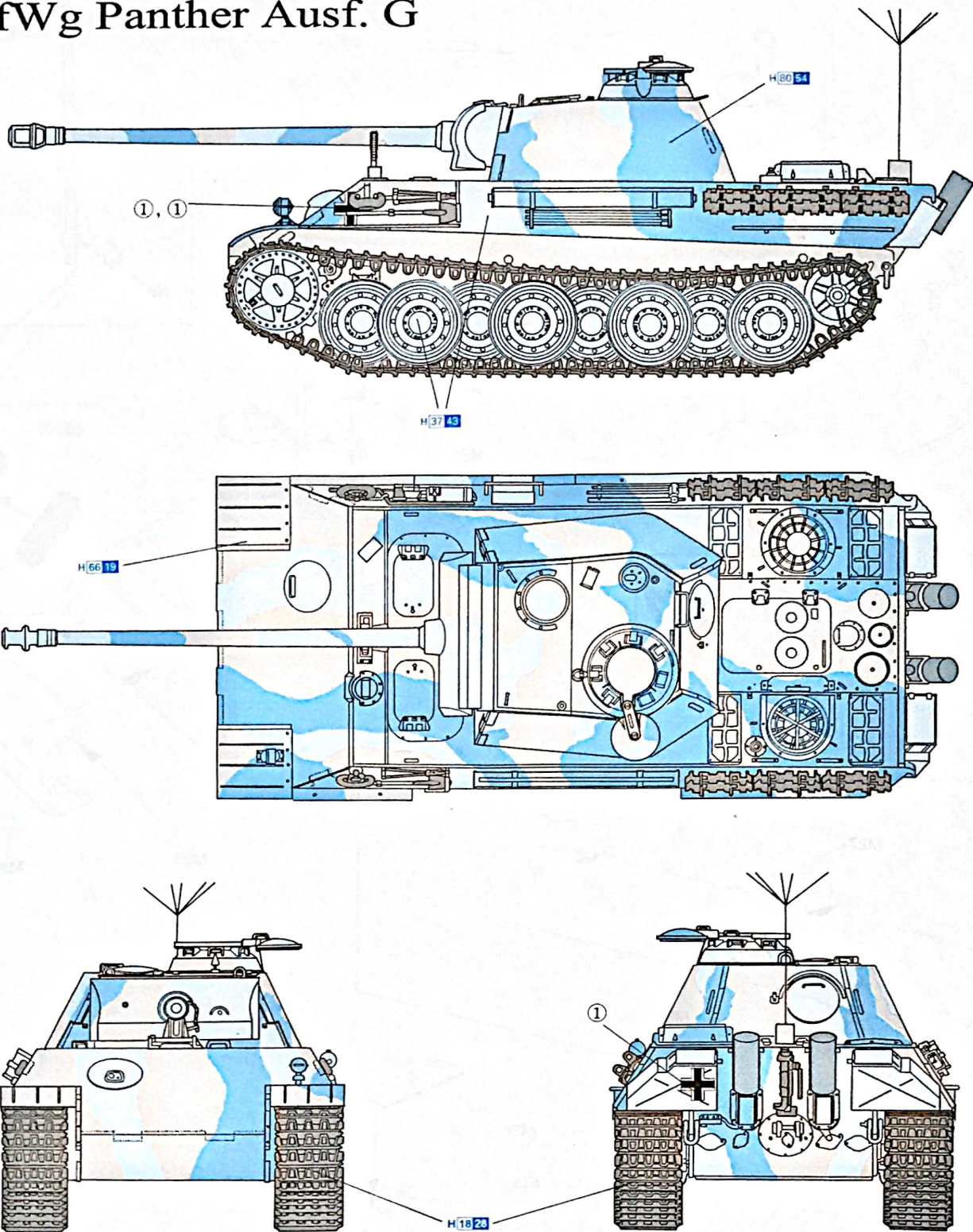

Copyright © 1997
9046-01

■デカールの貼り方

- ① デカールを貼るところのはこりや汚れを、ぬらした布できれいにふきとってください。
- ② 貼りたいデカールを台紙ごとハサミで切りとり、1枚づつ水またはぬるま湯に台紙を下にして20秒くらい浮かべます。
- ③ 水から出したらタオルの上のせ、指先でデカールが動くか確かめた後、貼るところにおいて静かに台紙をずします。
- ④ 指先に少し水をつけて正確な位置にデカールを動かした後、やわらかく、よく水を吸う布でデカールを押さえて内側の水分や気泡を押し出します。
- ⑤ デカールが完全に乾いたら少し水をつけた布で、デカールのまわりのノリをふきとります。

■Correct Method for Applying Decals

- ① Clean model surface with wet cloth.
- ② Cut each design out of decal sheet and dip them in warm water for 20 seconds.
- ③ Check with finger tip if design is loose on base paper. If so, place it on proper position on model and slide off base paper leaving design on model.
- ④ Move design to exact position with wet finger tip, and push out excess water and air bubbles under decal with soft cotton cloth.
- ⑤ When decals get dry, wipe off with wet cloth excess glue left around decals.

■Das Korrekte Aufbringen der Abziehbilder

- ① Oberfläche des Modells mit feuchtem Tuch reinigen
- ② Jedes Motiv einzeln aus dem Bogen herausschneiden und 20 Sekunden in warmes Wasser tauchen.
- ③ Mit dem Finger prüfen, ob sich das Motiv vom Trägerpapier gelöst hat. Wenn ja, so schieben Sie es vom Papier weg and seine genaue Position auf dem Modell
- ④ Korrigieren Sie die exakte Lage mit nasser Fingerspitze und drücken Sie Wasserblasen unter dem Abziehbild mit einem weichen Baumwolltuch weg
- ⑤ Entfernen Sie beim Antrocknen der Abziehbilder die Klebemittelränder mit einem feuchten Tuch.

■Comment appliquer les décalcomanies correctement

- ① Nettoyer la surface du modèle avec un chiffon humide.
- ② Découper chaque décalcomanie de sa feuille de papier et la plonger dans l'eau tiède pendant vingt secondes.
- ③ Vérifier avec le bout du doigt si le dessin se détache de son papier-support. Si oui, le positionner à l'endroit choisi sur le modèle et retirer doucement le papier-support.
- ④ Positionner la décalcomanie correctement avec un doigt humide et éponger tout restant d'eau et toutes bulles d'air sous la décalcomanie avec un chiffon doux.
- ⑤ Quand les décalcomanies sont sèche, détacher le colle autour des décalcomanies avec un chiffon humide.

■Modo esatto per applicare le decalcomanie

- ① Pulire la superficie del modello con un panno umido.
- ② Ritagliare ciascun disegno dal foglio decalcomanie e immergerli in acqua calda per 20 secondi.
- ③ Controllare col polpastrello se il disegno è allentato sulla base di carta. In questo caso, applicarlo nella esatta posizione sul modello facendolo scivolare dalla base di carta.
- ④ Spostare il disegno nella esatta posizione mediante il polpastrello umido, quindi togliere l'acqua in eccesso e le bolle d'aria sotto la decalcomania mediante un panno soffice di cotone.
- ⑤ Quando la decalcomanie sono asciutte, togliere con un panno umido l'eccesso di colla intorno alla decalcomania stessa.

■貼上水印標貼的正確方法：

- ① 用濕布抹乾淨模型表面。
- ② 按照各標貼的形狀從標貼紙上切出，浸到溫水之中約20秒。
- ③ 用指尖試行觸摸以確定標貼是否已脫離底紙，如果確實，則把標貼連底紙放到模型表面的適當位置上，小心地將底紙移去，把標貼留在模型表面。
- ④ 以濕水的指尖把標貼移到正確的位置上，再用柔軟的綿質布料把標貼輕壓，以擠出標貼底下的氣泡和水分。
- ⑤ 標貼乾後，用濕布輕拭標貼及其附近的模型表面，以洗去可能殘留在標貼附近的多餘膠水，確保效果完美。